**Dentistry — Sterile injection needles for
single use**

*Médecine bucco-dentaire — Aiguilles stériles pour injection, non
réutilisables*



Reference number
ISO 7885:2010(E)

© ISO 2010

PDF disclaimer

This PDF file may contain embedded typefaces. In accordance with Adobe's licensing policy, this file may be printed or viewed but shall not be edited unless the typefaces which are embedded are licensed to and installed on the computer performing the editing. In downloading this file, parties accept therein the responsibility of not infringing Adobe's licensing policy. The ISO Central Secretariat accepts no liability in this area.

Adobe is a trademark of Adobe Systems Incorporated.

Details of the software products used to create this PDF file can be found in the General Info relative to the file; the PDF-creation parameters were optimized for printing. Every care has been taken to ensure that the file is suitable for use by ISO member bodies. In the unlikely event that a problem relating to it is found, please inform the Central Secretariat at the address given below.



COPYRIGHT PROTECTED DOCUMENT

© ISO 2010

All rights reserved. Unless otherwise specified, no part of this publication may be reproduced or utilized in any form or by any means, electronic or mechanical, including photocopying and microfilm, without permission in writing from either ISO at the address below or ISO's member body in the country of the requester.

ISO copyright office
Case postale 56 • CH-1211 Geneva 20
Tel. + 41 22 749 01 11
Fax + 41 22 749 09 47
E-mail copyright@iso.org
Web www.iso.org

Published in Switzerland

Foreword

ISO (the International Organization for Standardization) is a worldwide federation of national standards bodies (ISO member bodies). The work of preparing International Standards is normally carried out through ISO technical committees. Each member body interested in a subject for which a technical committee has been established has the right to be represented on that committee. International organizations, governmental and non-governmental, in liaison with ISO, also take part in the work. ISO collaborates closely with the International Electrotechnical Commission (IEC) on all matters of electrotechnical standardization.

International Standards are drafted in accordance with the rules given in the ISO/IEC Directives, Part 2.

The main task of technical committees is to prepare International Standards. Draft International Standards adopted by the technical committees are circulated to the member bodies for voting. Publication as an International Standard requires approval by at least 75 % of the member bodies casting a vote.

Attention is drawn to the possibility that some of the elements of this document may be the subject of patent rights. ISO shall not be held responsible for identifying any or all such patent rights.

ISO 7885 was prepared by Technical Committee ISO/TC 106, *Dentistry*, Subcommittee SC 4, *Dental instruments*.

This third edition cancels and replaces the second edition (ISO 7885:2000), which has been technically revised as follows:

- a) deletion of requirement for patency of lumen;
- b) introduction of colour coding for smaller needle size 0,2;
- c) updated labelling requirements.

Introduction

This International Standard is closely related to ISO 7864. Requirements for validated sterilization processes are described in International Standards prepared by ISO/TC 198, *Sterilization of health care products*. (See references [6] to [8] in Bibliography.)

Specific qualitative and quantitative requirements for freedom from biological hazards are not included in this International Standard but it is recommended that, in assessing possible biological hazards, reference be made to ISO 10993-1, ISO 10993-11 and ISO 7405.

This International Standard specifies requirements for dental injection needles with metric sizes only. However, attention is drawn to the existence of dental injection needles with imperial threads (see Annex A).

Dentistry — Sterile injection needles for single use

1 Scope

This International Standard gives dimensional and performance requirements for sterile injection needles for single use which are used in dental cartridge syringes complying with ISO 9997 for injection of dental local anaesthetics. It further specifies requirements with respect to their packaging, labelling and colour coding. It does not cover needles for special applications or techniques.

Only the materials used for the construction of the needle tubing are specified.

2 Normative references

The following referenced documents are indispensable for the application of this document. For dated references, only the edition cited applies. For undated references, the latest edition of the referenced document (including any amendments) applies.

ISO 1942, *Dentistry — Vocabulary*

ISO 6009:1992, *Hypodermic needles for single use — Colour coding for identification*

ISO 7000, *Graphical symbols for use on equipment — Index and synopsis*

ISO 7864, *Sterile hypodermic needles for single use*

ISO 8601, *Data elements and interchange formats — Information interchange — Representation of dates and times*

ISO 9626, *Stainless steel needle tubing for the manufacture of medical devices*

ISO 9997, *Dental cartridge syringes*

ISO 15223-1, *Medical devices — Symbols to be used with medical device labels, labelling and information to be supplied — Part 1: General requirements*

3 Terms and definitions

For the purposes of this document, the terms and definitions given in ISO 1942 and the following apply.

3.1

needle unit

primary container, needle and hub

See Figure 1.

3.2 effective needle length

length of the needle from the needle tip to the hub

See Figure 1.

3.3 hardpack

needle unit, consisting of a rigid butt-end sheath and a rigid effective needle sheath, sealed to form a complete unit

See Figure 1.

3.4 softpack

needle unit, consisting of a preformed plastic tray with a peel-off cover, in which the needle is protected by a rigid sheath

NOTE A butt-end sheath might or might not be present.

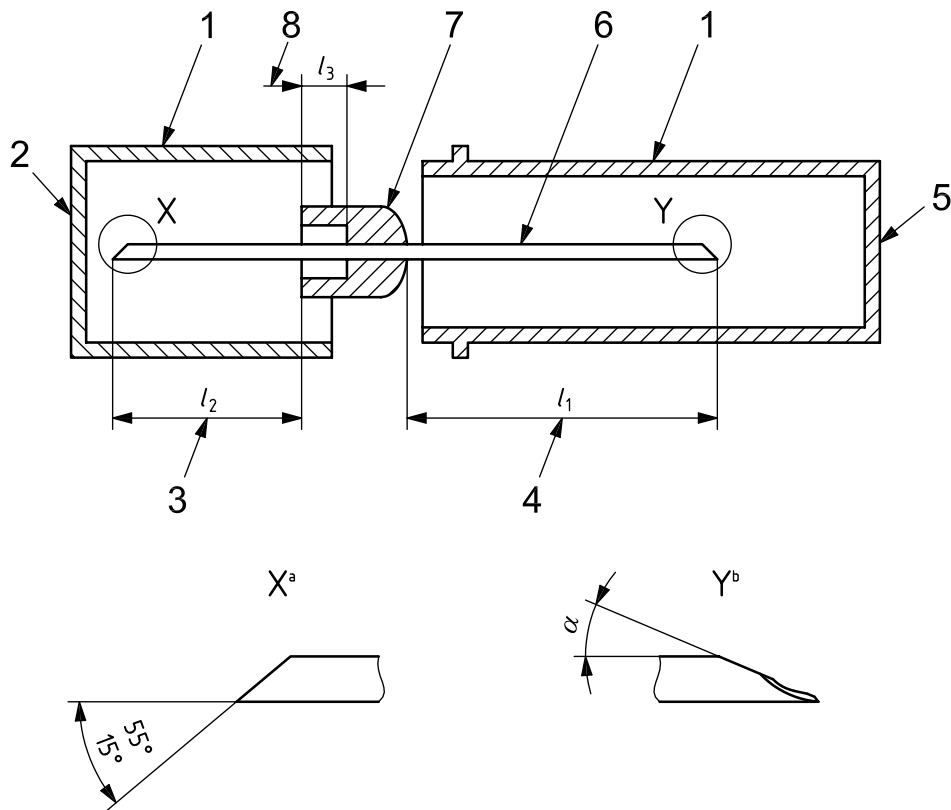

Key

- | | |
|--|---------------------------|
| 1 primary container (two parts) | 5 effective needle sheath |
| 2 butt-end sheath | 6 needle |
| 3 butt-end needle length (l_2) | 7 hub |
| 4 effective needle length (l_1) | 8 socket depth (l_3) |
| a Butt-end angle (15° to 55°). | |
| b Primary bevel angle (α). | |

Figure 1 — Schematic diagram of hardpack

3.5**primary container**

protective package, hardpack or softpack, for the needle

3.6**secondary container**

container in which primary containers are packed

4 Requirements of assembled needle and hub**4.1 Freedom from extraneous matter**

The surface of the assembled needle and hub shall be clean and free from extraneous matter when viewed by normal visual acuity without magnification. Lubricant on the external surface shall not be visible as droplets of fluid under normal visual acuity without magnification.

4.2 Limits for extractable metals

Limits and tests for extractable metals shall be in accordance with ISO 7864.

4.3 Union between hub and needle

The union between the hub and needle shall not break under a minimum force of 22 N applied at the crosshead speed of 1 mm/s in both directions along the needle axis.

4.4 Biocompatibility

See the Introduction for guidance on biocompatibility.

5 Requirements of needle tubing**5.1 Material**

The tubing used for construction of the needle shall comply with ISO 9626.

5.2 Dimensions

5.2.1 The nominal outside diameter of the needle tubing, in accordance with ISO 9626, shall be between 0,2 mm and 0,5 mm.

5.2.2 The effective needle length (see l_1 in Figure 1) of the needle tubing shall be within 10 % of that stated by the manufacturer.

5.2.3 The size of the needle shall be designated by the nominal outside diameter and the effective needle length, expressed in millimetres, e.g. 0,4 mm × 34 mm.

5.3 Butt end

5.3.1 The angle at the butt end shall be between 15° and 55° when measured through the long needle axis (see Figure 1).

5.3.2 The butt-end length (see l_2 in Figure 1) shall be between 9,0 mm and 14,0 mm.

5.4 Needle tip

The needle tip shall be pointed and, when examined under $\times 2,5$ magnification, shall appear free from feather edges, burrs, hooks and/or other defects. The angle of the primary bevel of the needle tip (see Figure 1) shall be within 2° of that stated by the manufacturer.

6 Requirements of hub

6.1 Compatibility with syringe

6.1.1 General

The hub may be threaded or unthreaded.

6.1.2 Threaded hubs

The internal thread in the hub shall fit on a metric form M6 \times 0,75.

6.1.3 Unthreaded hubs

If an internal thread is absent, the needle shall be capable of being securely screwed on to the threaded mounting hub of a cartridge syringe complying with ISO 9997.

6.2 Socket depth

The depth of the socket of the hub (l_3 in Figure 1) shall be not less than 5 mm.

6.3 Colour coding

The nominal outside diameter of the needle tubing shall be identified by colour coding in accordance with ISO 6009 (see Table 1 below). This colour coding shall be on the primary container or on the needle hub.

Attention is drawn to the sets of reference hubs available as reference colour samples (see Annex A of ISO 6009:1992).

The colour zones of opaque colours and the nearest colour samples in a number of colour atlases are given for information in Annexes B and C of ISO 6009:1992, respectively.

Table 1 — Colour code

Nominal outside diameter of needle	Colour
0,2	black
0,25	white
0,3	yellow
0,4	medium grey
0,5	orange

7 Requirements of the primary container

7.1 Each needle shall be supplied in a primary container.

7.2 The material and design of this container shall ensure

- maintenance of sterility,
- that, once opened, the container shall show clear evidence of having been opened,
- that the effective needle sheath can be used as an aid for attaching the needle to the syringe, without the operator touching the needle.

8 Sterility

The needle unit shall have been subjected to a validated sterilization process.

9 Labelling

The primary or secondary container shall be marked with at least the following information:

- a) name or trademark and address of manufacturer or distributor;
- b) size of needle (see 5.2.3);
- c) type of thread;
- d) the words “Sterile injection needle for single-use”;
- e) graphical symbol for single use in accordance with ISO 15223-1 or symbol ISO 7000-1051;
- f) the words “Do not use if seal is broken”, or “Do not use if soft pack is open or damaged”;
- g) (expiry date) use by date (year and month in accordance with ISO 8601) of the guaranteed sterility;
- h) method of sterilization;
- i) lot number;
- j) the number of single units in the secondary container.

Annex A
(informative)

Imperial thread sizes

The Introduction mentions the existence of imperial thread sizes for the threaded needle hubs. In the interest of patient safety, the imperial thread size used should be:

0,218 in (5,54 mm) 40 TPI (threads per inch) Whitworth form.

Bibliography

- [1] ISO 7405, *Dentistry — Evaluation of biocompatibility of medical devices used in dentistry*
- [2] ISO 10993-1, *Biological evaluation of medical devices — Part 1: Evaluation and testing within a risk management process*
- [3] ISO 10993-11, *Biological evaluation of medical devices — Part 11: Tests for systemic toxicity*
- [4] ISO 11499, *Dentistry — Single-use cartridges for local anaesthetics*
- [5] ISO 21533, *Dentistry — Reusable cartridge syringes intended for intraligamentary injections*
- [6] ISO 11135 (both parts), *Sterilization of health care products — Ethylene oxide*
- [7] ISO 11137 (all parts), *Sterilization of health care products — Radiation*
- [8] ISO 17665 (all parts), *Sterilization of health care products — Moist heat*

ICS 11.040.25; 11.060.20

Price based on 7 pages