International Standard



7797

INTERNATIONAL ORGANIZATION FOR STANDARDIZATION • МЕЖДУНАРОДНАЯ ОРГАНИЗАЦИЯ ПО СТАНДАРТИЗАЦИИ • ORGANISATION INTERNATIONALE DE NORMALISATION

Cross-country skis — Determination of breaking load and deflection at break with quasistatic load

Skis de fond — Détermination de la charge de rupture et de la déformation à la rupture sous charge quasi-statique

First edition — 1985-08-01

UDC 685.362.2 : 620.174.2

Ref. No. ISO 7797-1985 (E)

Descriptors : sports equipment, skis, cross country skis, tests, determination, breaking load, test equipment.

Foreword

ISO (the International Organization for Standardization) is a worldwide federation of national standards bodies (ISO member bodies). The work of preparing International Standards is normally carried out through ISO technical committees. Each member body interested in a subject for which a technical committee has been established has the right to be represented on that committee. International organizations, governmental and non-governmental, in liaison with ISO, also take part in the work.

Draft International Standards adopted by the technical committees are circulated to the member bodies for approval before their acceptance as International Standards by the ISO Council. They are approved in accordance with ISO procedures requiring at least 75 % approval by the member bodies voting.

International Standard ISO 7797 was prepared by Technical Committee ISO/TC 83, *Sports and recreational equipment*.

Cross-country skis — Determination of breaking load and deflection at break with quasistatic load

1 Scope and field of application

This International Standard specifies a method for determination of the resistance of defined parts of cross-country skis to breaking when quasistatically loaded.

A load applied to a ski usually leads to a predominantly elastic deformation followed by a sudden break. The optimum stiffness distribution, breaking strength and deflection at break depend on the application for which the ski is designed. These applications demand variations from stiff skis with high breaking strength, but relatively low deflection at break, to soft skis which can withstand large deflections, but have a relatively low strength. Consequently, the values of the breaking strength and breaking deflection cannot be directly related to the character of the ski.

The test is applicable to all sizes of cross-country skis for adults, juniors and children.

This test procedure shall not be used for determination of breaking load of ski structures with relatively high plastic deformation (for example skis with steel edges or skis with aluminium skins).

2 References

ISO 868, *Plastics — Determination of indentation hardness by means of a durometer (Shore hardness)*.

ISO 7264, *Cross-country skis — Dimensions of the binding mounting area for toe clip bindings*.

3 Definitions

For the purpose of this International Standard, the following definitions apply:

3.1 breaking load of the ski forebody, F_{B1} : Load which causes failure of the ski (breaking, delamination, buckling, etc.) when applied at the load application point midway between two supports 200 mm apart as described in 5.1.

3.2 breaking deflection of the ski forebody, f_{B1} : Deflection as a result of the application of the breaking load F_{B1} at which failure of the ski (breaking, delamination, buckling, etc.) occurs.

3.3 breaking load of the centrepart, F_{B2} : Load which causes failure of the ski (breaking, delamination, buckling, etc.) when applied at the load application point midway between two supports 500 mm apart as described in 5.2.

4 Test apparatus

The general arrangement of the test apparatus is shown in figure 1.

The test machine, usually a tensile tester with special bending fixture, shall comprise

- two supports, with adjustable distance in longitudinal direction, at least one of which shall be a low friction roller;
- a load cell having a range of at least 10 000 N for measurement of loads F_{B1} and F_{B2} ;
- a displacement measurement gauge for measurement of the deflection f_{B1} ;
- a ram plate as shown in figure 2, which shall consist of a steel plate, 4 mm thick, and a hard rubber layer, 3 mm thick and having a Shore A hardness of 95 ± 5 (see ISO 868);
- a load-displacement recorder for recording of the load-deflection curve on graph-paper.

5 Determination of the load application points

5.1 Load application point for determination of F_{B1} and f_{B1}

The load application point for the determination of F_{B1} and f_{B1} on the ski forebody shall be 175 mm behind the reference line where a 1 mm feeler gauge intersects the running surface, when the feeler gauge is inserted from the front side of the shovel, with the ski pressed on a flat surface by a sufficient load to flatten it. This load is located 80 mm behind the mounting point.

5.2 Load application point for the determination of F_{B2}

The load application point for determination of F_{B2} is located (80 ± 1) mm rearward from the binding mounting point according to ISO 7264 (see figure 3).

6 Conditioning

The test shall be carried out on skis conditioned to a temperature of $(23 \pm 5) ^\circ\text{C}$ and $(-10 \pm 2) ^\circ\text{C}$ for at least 2 h each.

7 Test procedure

7.1 Determination of F_{B1} and f_{B1}

Fix the ski on the supports as shown in figure 1 (support distance 200 mm). Load the ski at a rate sufficient to increase the deflection by 25 mm/min.

Record the load-deflection values by means of the load-displacement recorder.

7.2 Determination of F_{B2}

Fix the ski on the supports as shown in figure 3 (support distance 500 mm). Load the ski at a rate sufficient to increase the deflection by 25 mm/min.

Record the load-deflection values by means of the load-displacement recorder.

8 Evaluation

The breaking loads F_{B1} and F_{B2} and the deflection f_{B1} are the average values recorded on chart (see figure 4) from six skis (three pairs) with standard deviation.

9 Test report

The test report shall include the following information:

- reference to this International Standard;
- manufacturer and model designation of the ski;
- registration number and nominal length;
- test temperature;
- load-deflection charts for F_{B1} , f_{B1} and F_{B2} ;
- any deviation from the standard procedure with reasons.

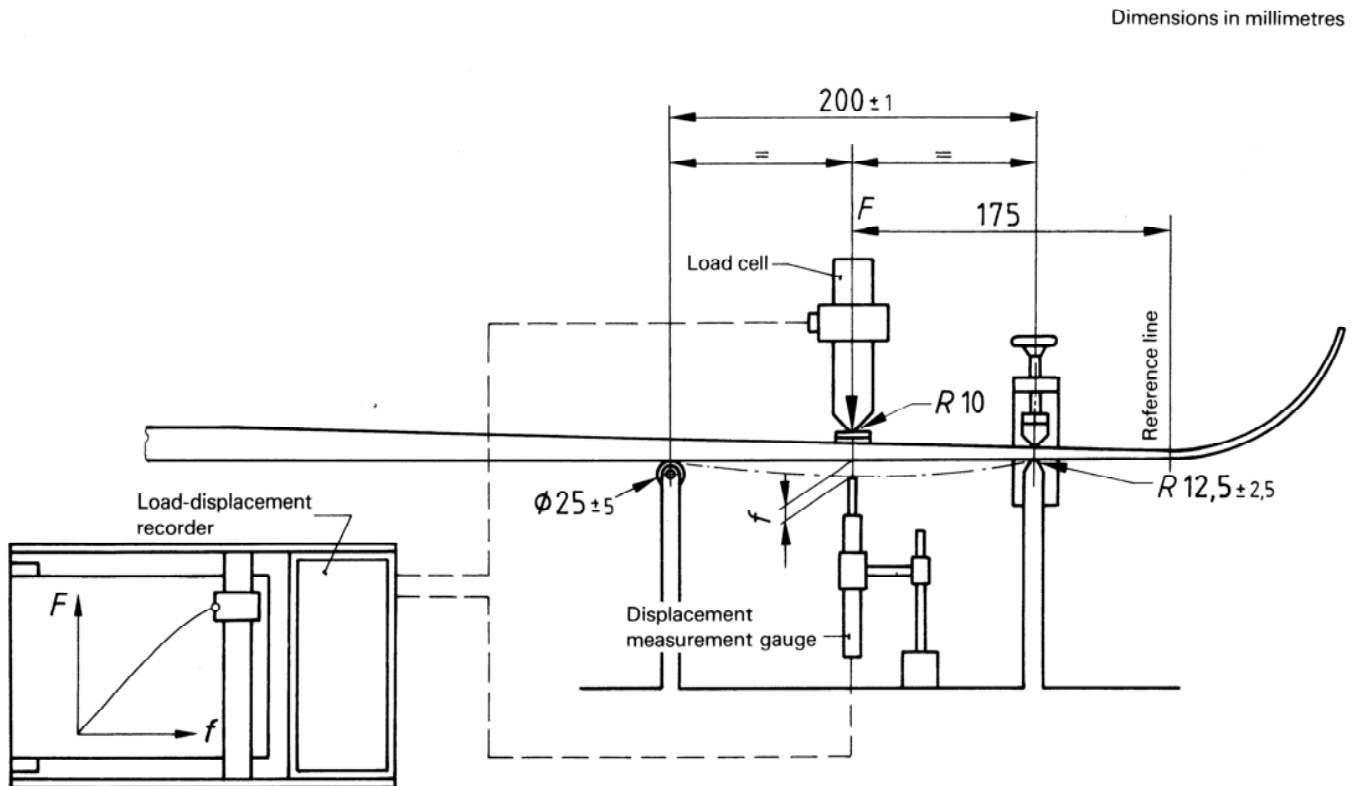
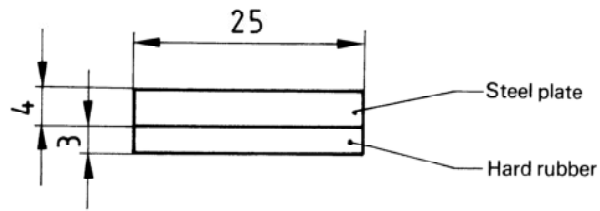
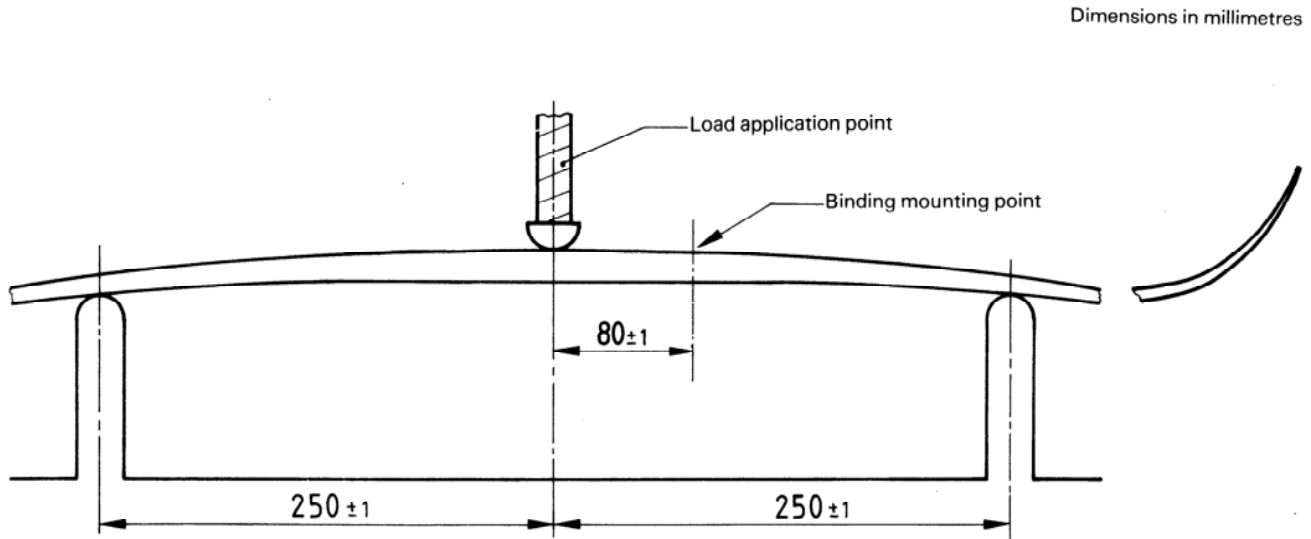

Figure 1 — Test apparatus



Dimensions in millimetres

Figure 2 – Ram plate



Dimensions in millimetres

Figure 3 – Load application point for the determination of F_{B2}

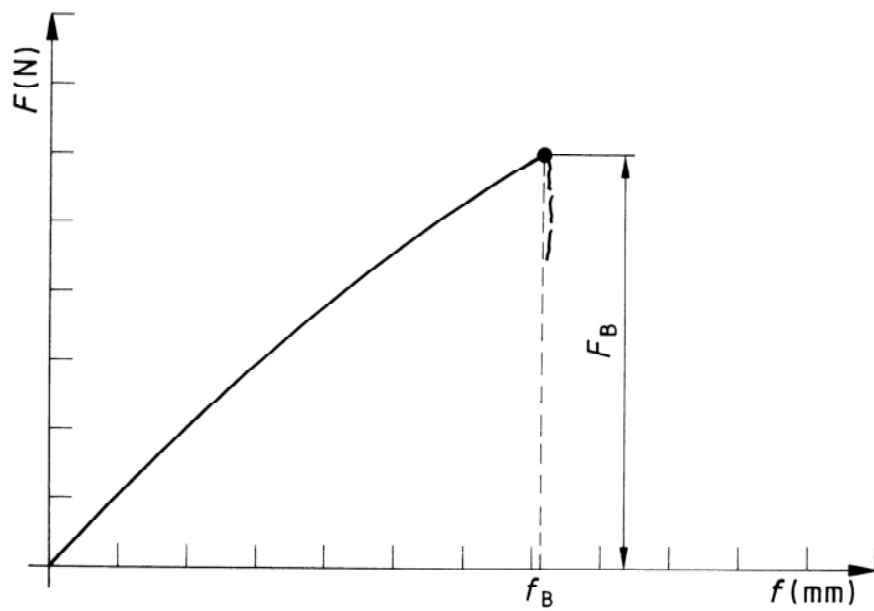

Figure 4 – Typical load-deflection curve

This page intentionally left blank

This page intentionally left blank

This page intentionally left blank