

---

---

**Cross-country skis — Ski-binding  
screws — Requirements**

*Skis de fond — Vis de fixation — Exigences*



Reference number  
ISO 7794:2011(E)

© ISO 2011



**COPYRIGHT PROTECTED DOCUMENT**

© ISO 2011

All rights reserved. Unless otherwise specified, no part of this publication may be reproduced or utilized in any form or by any means, electronic or mechanical, including photocopying and microfilm, without permission in writing from either ISO at the address below or ISO's member body in the country of the requester.

ISO copyright office  
Case postale 56 • CH-1211 Geneva 20  
Tel. + 41 22 749 01 11  
Fax + 41 22 749 09 47  
E-mail [copyright@iso.org](mailto:copyright@iso.org)  
Web [www.iso.org](http://www.iso.org)

Published in Switzerland

## Foreword

ISO (the International Organization for Standardization) is a worldwide federation of national standards bodies (ISO member bodies). The work of preparing International Standards is normally carried out through ISO technical committees. Each member body interested in a subject for which a technical committee has been established has the right to be represented on that committee. International organizations, governmental and non-governmental, in liaison with ISO, also take part in the work. ISO collaborates closely with the International Electrotechnical Commission (IEC) on all matters of electrotechnical standardization.

International Standards are drafted in accordance with the rules given in the ISO/IEC Directives, Part 2.

The main task of technical committees is to prepare International Standards. Draft International Standards adopted by the technical committees are circulated to the member bodies for voting. Publication as an International Standard requires approval by at least 75 % of the member bodies casting a vote.

Attention is drawn to the possibility that some of the elements of this document may be the subject of patent rights. ISO shall not be held responsible for identifying any or all such patent rights.

ISO 7794 was prepared by Technical Committee ISO/TC 83, *Sports and recreational equipment*, Subcommittee SC 4, *Snowsports equipment*.

This third edition cancels and replaces the second edition (ISO 7794:1991), which has been technically revised.

## Introduction

The use of ski-binding screws that comply with the requirements of this International Standard will improve binding mounting. By standardizing the drill hole diameter, recommendations by the manufacturers will no longer be required, while mistakes and improper mounting, caused by differences in instructions, will be avoided. Standardization of the penetration depth will enable ski manufacturers to design their products so that there will be sufficient thickness in the mounting area and suitable positioning of reinforced parts to make optimum use of the fastening characteristics.

The proposed values for driving torque and stripping torque will enable adjustable torque-limiting screwdrivers to be used with the same adjustment for all skis.

The use of the cross-recess type Z No. 3 screw will also contribute significantly to simplifying the binding mounting procedure.

# Cross-country skis — Ski-binding screws — Requirements

## 1 Scope

This International Standard specifies the dimensions, mechanical properties, mounting and fastening characteristics of screws used for mounting ski bindings on cross-country skis.

The purpose of this International Standard is to facilitate the design of a more rational and safer binding mounting system.

## 2 Normative references

The following referenced documents are indispensable for the application of this document. For dated references, only the edition cited applies. For undated references, the latest edition of the referenced document (including any amendments) applies.

ISO 1478, *Tapping screws thread*

ISO 2702, *Heat-treated steel tapping screws — Mechanical properties*

ISO 7795, *Cross-country skis — Ski-binding screws — Test methods*

## 3 Terms and definitions

For the purposes of this document, the following terms and definitions apply.

### 3.1

#### **ski-binding screw**

fastener which, after mounting, ensures the connection of binding and ski by axial pre-tension

### 3.2

#### **penetration depth**

distance from the top surface of the ski to the lower extremity of the ski-binding screw

### 3.3

#### **driving torque**

maximum value of the moment required to drive the ski-binding screw into the drill hole of the test specimen without lubrication or tapping

### 3.4

#### **tightening torque**

moment, specified in the mounting instructions or in the test procedure, which is used to tighten the ski-binding screw to ensure sufficient fastening

### 3.5

#### **stripping torque**

maximum measurable moment which causes damage to the internal thread in the test assembly, or to the thread of the screw if the already tightened screw is further loaded by a driving moment

### 3.6

#### static pull-out resistance

resistance of the test assembly to a pull-out force applied to one screw quasistatically in the axial direction

## 4 Designation

Cross-country ski-binding screws in accordance with this International Standard shall be designated by:

- a) the words “cross-country ski-binding screws”, and the abbreviation “XCSBS”;
- b) the reference of this International Standard, i.e. ISO 7794;
- c) their nominal dimensions, i.e. diameter × length;
- d) the type of screw head.

**EXAMPLE** Cross-country ski-binding screws of nominal diameter 6,0 mm and length 17 mm, with countersunk heads would be designated:

**Cross-country ski-binding screws XCSBS ISO 7794 – 6,0 × 17 with countersunk heads**

## 5 Requirements

### 5.1 General

The strength requirements and typical application characteristics of cross-country ski-binding screws are tested in accordance with ISO 7795.

### 5.2 Materials

Cross-country ski-binding screws shall be made of steel as specified in ISO 2702, which shall comply with the additional requirements in 5.4 and 5.5 of this International Standard.

### 5.3 Dimensions

#### 5.3.1 Screw head

Cross-country ski-binding screws shall be cross recess type Z No. 3 with a recommended minimum penetration depth of 2,72 mm to 3,18 mm (see ISO 4757).

If screws having countersunk heads are used, the angle of countersinking  $90^{\circ} \begin{smallmatrix} +2^{\circ} \\ 0 \end{smallmatrix}$  is recommended.

#### 5.3.2 Thread and tip configuration

The cross-section of the screw may be circular or non circular within the major diameter of  $6,3 \text{ mm} \begin{smallmatrix} 0 \\ -0,15 \end{smallmatrix}$  mm (see Figure 1).

The tolerance shall be in accordance with Figure 1.

The thread should be extended up to the screw head but shall be at least 1 mm longer than the penetration depth.

The shaft end shall correspond to Figure 1.

Dimensions in millimetres

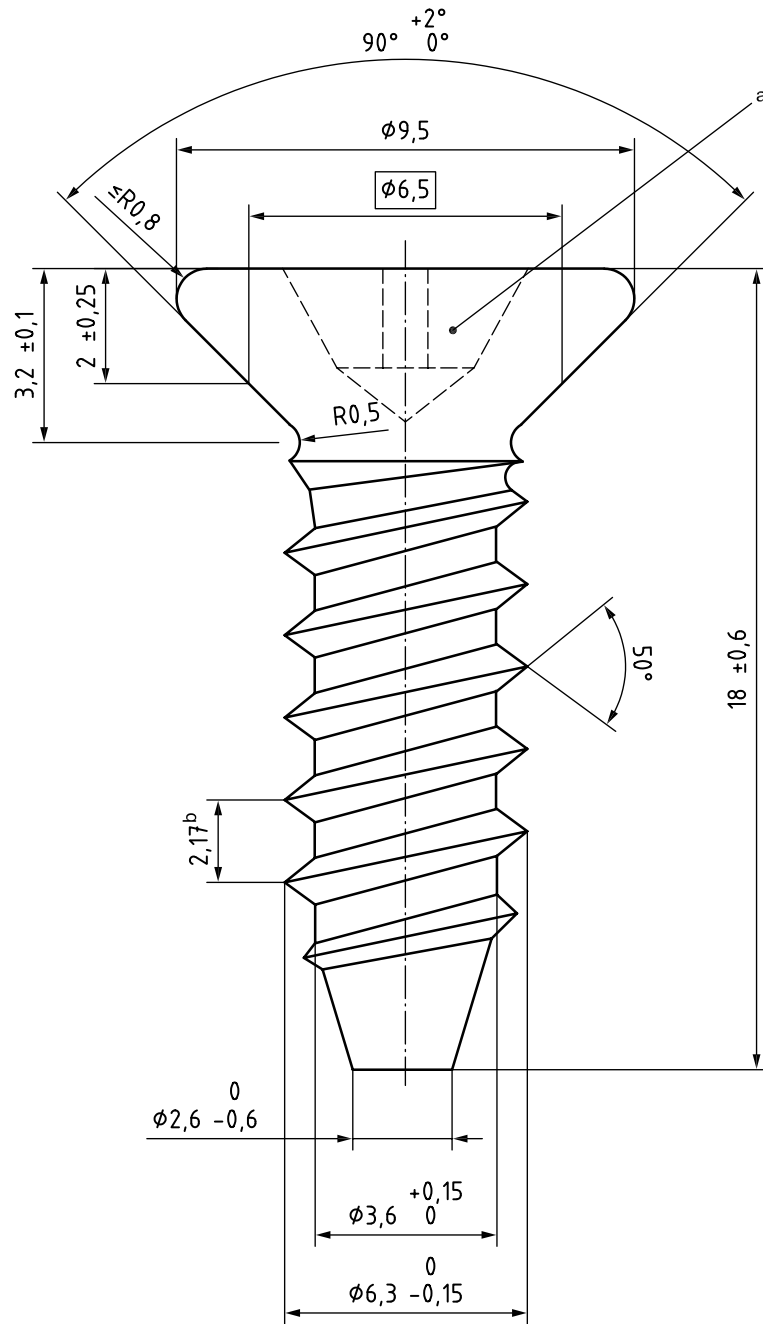

- a Cross-recess type Z No. 3 in accordance with ISO 4757.
- b Pitch.

Figure 1 — Thread and end configuration

## 5.4 Surface

Ski-binding screws shall be coated or plated with materials which provide adequate protection against corrosion and ensure a reproducible coefficient of friction.

For example, a suitable coating would be a zinc electroplated coating, Fe/Zn 5c (see ISO 4042), having a clear chromate conversion coating and a minimum local thickness of 5 µm (batch average 4 µm min., 6 µm max.), when measured on the top surface of the screw head.

During electroplating, adequate precautions shall be taken to avoid hydrogen embrittlement.

## 5.5 Application characteristics

### 5.5.1 General

The specified fastening and mounting characteristics of the screw shall be based on a uniform drill diameter of  $3,6 \text{ mm}^{+0,15}_0$  mm.

### 5.5.2 Strength requirements

The screw head shall not be damaged when submitted to the following torques:

- a) a driving torque of not more than 2 N·m;
- b) a stripping torque of not less than 3,5 N·m.

### 5.5.3 Fastening characteristics

The mean static pull-out resistance shall correspond to at least that of a reference screw complying with the requirements of ISO 1478, type F, and having a diameter of 6,3 mm.



## Bibliography

- [1] ISO 4042, *Fasteners — Electroplated coatings*
- [2] ISO 4757, *Cross recesses for screws*

---

---

**ICS 97.220.20**

Price based on 5 pages