

---

---

**Paints and varnishes — Determination  
of resistance to abrasion —**

**Part 3:  
Method with abrasive-paper covered  
wheel and linearly reciprocating test  
specimen**

*Peintures et vernis — Détermination de la résistance à l'abrasion —  
Partie 3: Méthode utilisant une roue revêtue de papier abrasif et une  
éprouvette animée d'un mouvement de va-et-vient linéaire*



**COPYRIGHT PROTECTED DOCUMENT**

© ISO 2016, Published in Switzerland

All rights reserved. Unless otherwise specified, no part of this publication may be reproduced or utilized otherwise in any form or by any means, electronic or mechanical, including photocopying, or posting on the internet or an intranet, without prior written permission. Permission can be requested from either ISO at the address below or ISO's member body in the country of the requester.

ISO copyright office  
Ch. de Blandonnet 8 • CP 401  
CH-1214 Vernier, Geneva, Switzerland  
Tel. +41 22 749 01 11  
Fax +41 22 749 09 47  
copyright@iso.org  
www.iso.org

# Contents

Page

<b>Foreword</b> .....	<b>iv</b>
<b>Introduction</b> .....	<b>v</b>
<b>1 Scope</b> .....	<b>1</b>
<b>2 Normative references</b> .....	<b>1</b>
<b>3 Terms and definitions</b> .....	<b>1</b>
<b>4 Principle</b> .....	<b>2</b>
<b>5 Apparatus and materials</b> .....	<b>3</b>
<b>6 Test specimens</b> .....	<b>4</b>
6.1 Preparation of test specimens.....	4
6.2 Film thickness.....	4
6.3 Conditioning.....	4
<b>7 Procedure</b> .....	<b>4</b>
7.1 Agreements.....	4
7.2 Preparation of the abrasive wheel.....	4
7.3 Test conditions.....	5
7.4 Number of determinations.....	5
7.5 General test procedure.....	5
7.6 Procedure of the pre-test.....	5
7.7 Procedure of the main test.....	6
<b>8 Evaluation of the main test</b> .....	<b>6</b>
8.1 Loss in mass by abrasion.....	6
8.2 Abrasion resistance.....	6
<b>9 Precision</b> .....	<b>6</b>
9.1 General.....	6
9.2 Repeatability limit.....	6
9.3 Reproducibility limit.....	6
<b>10 Test report</b> .....	<b>7</b>
<b>Bibliography</b> .....	<b>8</b>

## Foreword

ISO (the International Organization for Standardization) is a worldwide federation of national standards bodies (ISO member bodies). The work of preparing International Standards is normally carried out through ISO technical committees. Each member body interested in a subject for which a technical committee has been established has the right to be represented on that committee. International organizations, governmental and non-governmental, in liaison with ISO, also take part in the work. ISO collaborates closely with the International Electrotechnical Commission (IEC) on all matters of electrotechnical standardization.

The procedures used to develop this document and those intended for its further maintenance are described in the ISO/IEC Directives, Part 1. In particular the different approval criteria needed for the different types of ISO documents should be noted. This document was drafted in accordance with the editorial rules of the ISO/IEC Directives, Part 2 (see [www.iso.org/directives](http://www.iso.org/directives)).

Attention is drawn to the possibility that some of the elements of this document may be the subject of patent rights. ISO shall not be held responsible for identifying any or all such patent rights. Details of any patent rights identified during the development of the document will be in the Introduction and/or on the ISO list of patent declarations received (see [www.iso.org/patents](http://www.iso.org/patents)).

Any trade name used in this document is information given for the convenience of users and does not constitute an endorsement.

For an explanation on the meaning of ISO specific terms and expressions related to conformity assessment, as well as information about ISO's adherence to the WTO principles in the Technical Barriers to Trade (TBT) see the following URL: [Foreword - Supplementary information](#)

The committee responsible for this document is ISO/TC 35, *Paints and varnishes*, Subcommittee SC 9, *General test methods for paints and varnishes*.

This second edition cancels and replaces the first edition (ISO 7784-3:2000), which has been technically revised with the following changes:

- a) the title has been changed;
- b) the terms and definitions clause has been amended;
- c) a figure explaining the principle of the method was amended;
- d) the supplementary test conditions previously in Annex A have been integrated in the test report;
- e) the calibration of the apparatus previously in Annex B has been deleted;
- f) the test procedure has been re-arranged;
- g) the text has been editorially revised and the normative references have been updated.

ISO 7784 consists of the following parts, under the general title *Paints and varnishes — Determination of resistance to abrasion*:

- *Part 1: Method with abrasive-paper covered wheels and rotating test specimen*
- *Part 2: Method with abrasive rubber wheels and rotating test specimen*
- *Part 3: Method with abrasive-paper covered wheel and linearly reciprocating test specimen*

## Introduction

This part of ISO 7784 is one of the three parts of ISO 7784 dealing with test methods for the determination of the resistance to abrasion of coatings using abrasive wheels. The characteristics and differences of these methods are summarized in [Table 1](#).

**Table 1 — Types of method**

Standard	Abrasive wheel		Test specimen movement
	Type	Degree of freedom	
ISO 7784-1	Abrasive paper on rubber wheel	Freely rotatable	Rotation
ISO 7784-2	Abrasive rubber wheel		
ISO 7784-3	Abrasive paper on metal wheel	Rigid – with stroke-dependent rotation <sup>a</sup>	Linear reciprocation

<sup>a</sup> A mechanism rotates the abrasive wheel by a small angle after each double stroke so that a new area of the abrasive paper is effective.

The methods using abrasive-paper covered wheels (ISO 7784-1 and ISO 7784-3) are preferably to be applied.



# Paints and varnishes — Determination of resistance to abrasion —

## Part 3: Method with abrasive-paper covered wheel and linearly reciprocating test specimen

### 1 Scope

This part of ISO 7784 specifies a method for determining the resistance to abrasion of coatings, for which a loaded, rigid abrasive-paper covered wheel affects the coating of the linearly reciprocating test specimen.

### 2 Normative references

The following documents, in whole or in part, are normatively referenced in this document and are indispensable for its application. For dated references, only the edition cited applies. For undated references, the latest edition of the referenced document (including any amendments) applies.

ISO 1514, *Paints and varnishes — Standard panels for testing*

ISO 2808, *Paints and varnishes — Determination of film thickness*

ISO 3270, *Paints and varnishes and their raw materials — Temperatures and humidities for conditioning and testing*

ISO 4618, *Paints and varnishes — Terms and definitions*

ISO 7823-1, *Plastics — Poly(methyl methacrylate) sheets — Types, dimensions and characteristics — Part 1: Cast sheets*

### 3 Terms and definitions

For the purposes of this document, the terms and definitions given in ISO 4618 and the following apply.

#### 3.1

##### **test specimen**

specimen on which the test is to be carried out

#### 3.2

##### **double stroke**

##### **ds**

one complete reciprocal movement made by the abrasive wheel

#### 3.3

##### **repeatability conditions**

conditions where independent test results are obtained with the same method on identical test items in the same laboratory by the same operator using the same equipment within short intervals of time

[SOURCE: ISO 5725-1:1994, 3.14]

**3.4**  
**repeatability limit**

*r*  
value less than or equal to which the absolute difference between two test results obtained under *repeatability conditions* (3.3) may be expected to be with a probability of 95 %

[SOURCE: ISO 5725-1:1994, 3.16]

**3.5**  
**reproducibility conditions**

conditions where test results are obtained with the same method on identical test items in different laboratories with different operators using different equipment

[SOURCE: ISO 5725-1:1994, 3.18]

**3.6**  
**reproducibility limit**

*R*  
value less than or equal to which the absolute difference between two test results obtained under *reproducibility conditions* (3.5) may be expected to be with a probability of 95 %

[SOURCE: ISO 5725-1:1994, 3.20]

**4 Principle**

A rigid abrasive wheel, covered with abrasive paper, is pressed onto the coating applying the test load. The test specimen is reciprocated with specified stroke length and double-stroke frequency. The abrasive wheel itself is rotated by a small angle after each double stroke, so that a new fresh portion of the abrasive paper is applied. The specimen is set with its testing surface facing downward, and the testing surface is abraded from underneath.

Figure 1 illustrates the test principle.

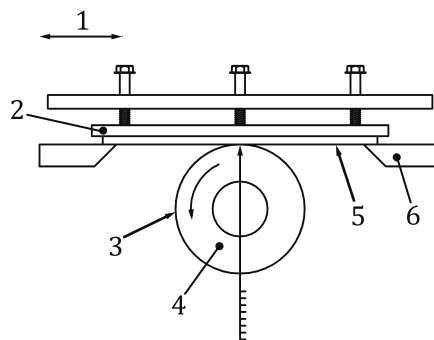

- Key**
- 1 reciprocating motion
  - 2 specimen press
  - 3 abrasive paper
  - 4 abrasive wheel
  - 5 specimen
  - 6 specimen stage

**Figure 1 — Principle of the abrasion test with linearly reciprocating test specimen**



## 5 Apparatus and materials

**5.1 Abrasive-wheel-wear test apparatus**, consisting of a clamping device with pressure plate for holding the test specimen level and rigid, and a 50 mm diameter wheel to the outer circumference of which is attached a 12 mm wide strip of the abrasive paper (5.2). The force between the wheel and the testing surface shall be capable of being varied from 0,98 N to at least 6,9 N with an accuracy of  $\pm 0,05$  N. The abrasive action is produced by the test specimen sliding to and fro in a horizontal plane in parallel contact with the testing surface over a 30 mm length over the abrasive wheel. Typical apparatus is illustrated in Figure 2.

After each double stroke, the wheel is advanced through a small angle to bring a new fresh portion of the abrasive paper into contact with the testing surface before making the next double stroke (400 ds in maximum). The relative speed of movement shall be  $(40 \pm 2)$  ds per minute. The testing surface shall be kept free from loose powder or abrasion debris during the test.

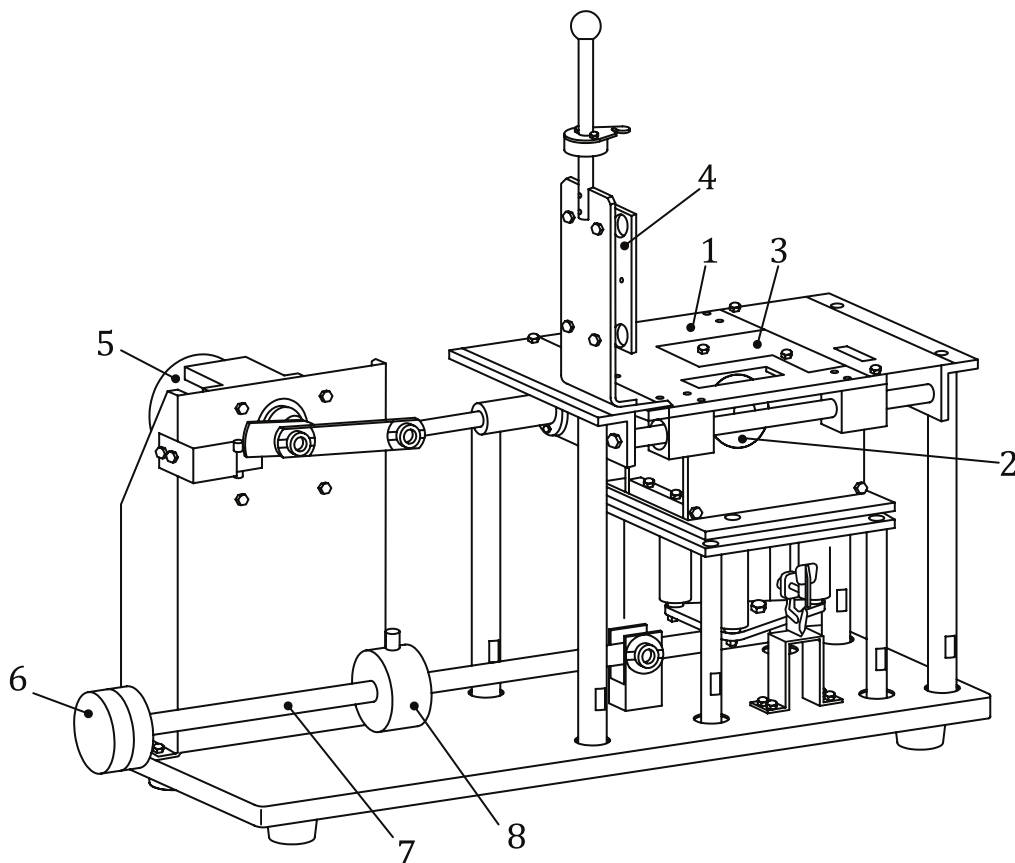

### Key

1	specimen stage	5	specimen reciprocating motor
2	abrasive wheel	6	load
3	specimen guide	7	load scale
4	specimen press	8	load adjust

**Figure 2 — Abrasive-wheel-wear test apparatus (example)**

**5.2 Abrasive paper.** The recommended abrasive paper is grain size P180 silicon carbide paper (ISO 6344-1). The strip shall be  $(12,0 \pm 0,2)$  mm wide. Its length shall be such that it covers the abrasive wheel without overlap or gap at the ends, a strip length of 158 mm is sufficient. In case the strips of

abrasive paper are cut at an angle (45°) prior to adhering (see [Figure 3](#)), a minimum length of 170 mm is required. The strip shall be attached to the wheel by double-sided adhesive tape or self-adhesive abrasive paper shall be used.

Other types of abrasive paper may be used by agreement between the interested parties.

**5.3 Balance**, with an accuracy of 0,1 mg.

## 6 Test specimens

### 6.1 Preparation of test specimens

The test specimens shall be plane, have the minimum dimensions of 30 mm × 50 mm, and be prepared, coated, and dried/hardened in accordance with ISO 1514.

Typical dimensions for a test specimen are 50 mm × 50 mm × (1 mm to 5 mm).

NOTE For a common apparatus, the maximum dimension of the test specimens of 100 mm × 300 mm is allowable.

### 6.2 Film thickness

Determine the dry-film thickness of the coating, in micrometres, in accordance with one of the methods specified in ISO 2808.

### 6.3 Conditioning

Prior to testing, condition the coated test specimens at a temperature of  $(23 \pm 2)$  °C and a relative humidity of  $(50 \pm 5)$  % (in accordance with ISO 3270), if not agreed otherwise, for at least 16 h.

## 7 Procedure

### 7.1 Agreements

For carrying out the test, the abrasive material and the grain size of the abrasive paper ([5.2](#)) shall be agreed.

If necessary, the agreed grain size of the abrasive paper and/or the specified values of the test load [ $(6,9 \pm 0,1)$  N] have to be adjusted to the results of the pre-test in [7.6](#) (see [7.6.4](#) and [7.6.5](#)).

### 7.2 Preparation of the abrasive wheel

Condition the strip of abrasive paper ([5.2](#)), (and, if necessary, the adhesive tape) in accordance with [6.3](#) and adhere them to the circumference of the wheel ([5.1](#)) without any gaps or overlapping.

It is recommended that strips of abrasive paper be cut at an angle of 45° and joined respectively when adhering (see [Figure 3](#)).

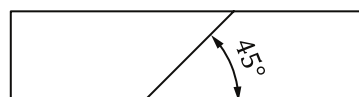

**Figure 3 — Recommended method of joining the ends of the abrasive paper strip**

### 7.3 Test conditions

Carry out the test at a temperature of  $(23 \pm 2)$  °C and measure the relative humidity during the test and state it in the test report.

Carry out the test as quick as possible, however, not later than 30 min after the conditioning phase.

### 7.4 Number of determinations

Carry out the determination in triplicate on three separate test specimens.

### 7.5 General test procedure

**7.5.1** Weigh the test specimen to the nearest 0,1 mg using the balance (5.3) and mount it to the device so that the abrasion area is at least 5 mm off the edge of the test specimen.

**7.5.2** Mount the abrasive wheel, prepared in accordance with 7.2.

**7.5.3** Pre-set the agreed test load on the device.

**7.5.4** Calibrate the counter to the agreed number of double strokes and start the stroke motion.

**7.5.5** Clean the test specimen using a lint-free cloth and weigh to the nearest 0,1 mg.

### 7.6 Procedure of the pre-test

**7.6.1** Carry out the working steps 7.5.1 to 7.5.5 on several test specimens under the following test conditions:

- grain size of the abrasive paper in accordance with 7.1 or a coarser grain size in accordance with 7.6.4;
- test load  $(6,9 \pm 0,1)$  N;
- number of double strokes 10, 30, 50 and 100.

**7.6.2** Calculate the loss in mass of the coating for each number of double strokes as difference of the test specimen masses in accordance with 7.5.1 and 7.5.5, in milligrams.

**7.6.3** Determine, whether the relationship between the values of the losses in mass and the corresponding numerical values of the double strokes is linear (e.g. by means of a schematic diagram).

**7.6.4** In case the relationship in accordance with 7.6.3 is not linear, select a coarser grain size for the abrasive paper and/or a smaller test load. Repeat working steps 7.5.1 to 7.5.3 with these new test parameters in order to verify the linearity.

**7.6.5** If the coating shows loss of adhesion or is abraded through to the substrate or, in the case of a multicoat system, the topcoat is abraded through to an undercoat, then alter the test conditions so that this no longer occurs.

The following adjustments are recommended:

- decreasing the load on the specimen;
- changing the abrasive paper to a finer grain size;
- increasing the thickness of the film on the test specimen.

## 7.7 Procedure of the main test

Carry out the working steps [7.5.1](#) to [7.5.5](#) on three test specimens for 100 ds under the following test conditions:

- grain size of the abrasive paper in accordance with [7.1](#), [7.6.4](#), or [7.6.5](#);
- test load  $(6,9 \pm 0,1)$  N or a smaller test load in accordance with [7.6.4](#) or [7.6.5](#).

## 8 Evaluation of the main test

### 8.1 Loss in mass by abrasion

**8.1.1** Calculate the loss in mass of the coating as difference of the masses of the test specimens in accordance with [7.6.1](#) and [7.6.5](#), in milligrams.

**8.1.2** For test result, report to the nearest 0,1 mg the mean value of the losses in mass of the three test specimens (see [8.1.1](#)), along with the three individual losses in mass.

### 8.2 Abrasion resistance

The abrasion resistance of the coating can be calculated from the mean value of the loss in mass in accordance with [8.1.2](#).

$$\text{abrasion resistance (ds/mg)} = 100 / (\text{mean value of the loss in mass in milligrams})$$

## 9 Precision

### 9.1 General

The precision of the method depends on the characteristics of the product tested. For the transparent poly(methyl methacrylate) (PMMA) sheet specified in ISO 7823-1, the following values are valid.

### 9.2 Repeatability limit

The repeatability limit,  $r$ , is 10 %. The value is given in [Table 2](#).

### 9.3 Reproducibility limit

The reproducibility limit,  $R$ , is 22 %. The value is given in [Table 2](#).

Table 2 — Precision data obtained from a single make and model of instrument

Material No.	Mean value of five laboratories <i>m</i> mg	Standard deviation of five laboratories <i>s<sub>x</sub></i> mg	Repeatability standard deviation <i>s<sub>r</sub></i> mg	Reproducibility standard deviation <i>s<sub>R</sub></i> mg	Repeatability limit		Reproducibility limit	
					<i>r</i> mg	%	<i>R</i> mg	%
A	11,2	0,80	0,38	0,86	1,06	9,4	2,37	21,2
B	24,1	0,60	0,68	0,81	1,89	7,8	2,26	9,4
C	87,3	2,62	2,94	3,55	8,14	9,3	9,84	11,3

NOTE 1 These values are based on the round-robin test performed in Japan, carried out under the following test conditions:  
test specimens: transparent PMMA sheet specified in ISO 7823-1;  
temperature and humidity: 23 °C, 65 %;  
abrasive paper: P180;  
load: 4,9 N;  
speed: 40 ds/min.;  
abrasion: 100 ds.

NOTE 2 The precision data gathered from five different laboratories, made on a single make and model instrument.

## 10 Test report

The test report shall include at least the following information:

- a) all details necessary to identify and characterize the test specimen, i.e. details regarding
  - 1) coating (manufacturer, product identification, batch number, application method, drying/hardening/ageing conditions, etc.), and
  - 2) substrate (material, thickness, pre-treatment, etc.);
- b) the film thickness, in micrometres, in accordance with [6.2](#);
- c) a reference to this part of ISO 7784, i.e. ISO 7784-3;
- d) the grain size of abrasive paper;
- e) the test load, in newtons;
- f) the temperature and relative humidity during testing;
- g) the test result in accordance with [Clause 8](#) (the mean and three individual losses in mass, the abrasion resistance);
- h) any deviation from the test method specified;
- i) any unusual features (anomalies) observed during the test;
- j) the name of the operator and the testing laboratory;
- k) the date of the test.

## Bibliography

- [1] ISO 5725-1:1994, *Accuracy (trueness and precision) of measurement methods and results — Part 1: General principles and definitions*
- [2] ISO 6344-1, *Coated abrasives — Grain size analysis — Part 1: Grain size distribution test*
- [3] ISO 8251, *Anodizing of aluminium and its alloys — Measurement of abrasion resistance of anodic oxidation coatings*
- [4] ISO 10074, *Anodizing of aluminium and its alloys — Specification for hard anodic oxidation coatings on aluminium and its alloys*
- [5] ASTM D 6037, *Standard Test Methods for Dry Abrasion Mar Resistance of High Gloss Coatings*



