

H-56-30

INTERNATIONAL STANDARD

ISO 7765-1

First edition
1988-12-15



INTERNATIONAL ORGANIZATION FOR STANDARDIZATION
ORGANISATION INTERNATIONALE DE NORMALISATION
МЕЖДУНАРОДНАЯ ОРГАНИЗАЦИЯ ПО СТАНДАРТИЗАЦИИ

Plastics film and sheeting — Determination of impact resistance by the free-falling dart method

Part 1: Staircase methods

Film et feuille de plastiques — Détermination de la résistance au choc par la méthode par chute libre de projectile

Partie 1: Méthodes dites de «l'escalier»

Reference number
ISO 7765-1:1988 (E)

ISO 7765-1 : 1988 (E)

Foreword

ISO (the International Organization for Standardization) is a worldwide federation of national standards bodies (ISO member bodies). The work of preparing International Standards is normally carried out through ISO technical committees. Each member body interested in a subject for which a technical committee has been established has the right to be represented on that committee. International organizations, governmental and non-governmental, in liaison with ISO, also take part in the work. ISO collaborates closely with the International Electrotechnical Commission (IEC) on all matters of electrotechnical standardization.

Draft International Standards adopted by the technical committees are circulated to the member bodies for approval before their acceptance as International Standards by the ISO Council. They are approved in accordance with ISO procedures requiring at least 75 % approval by the member bodies voting.

International Standard ISO 7765-1 was prepared by Technical Committee ISO/TC 61, *Plastics*.

ISO 7765 consists of the following parts, under the general title *Plastics film and sheeting — Determination of impact resistance by the free-falling dart method*:

- *Part 1: Staircase methods*
- *Part 2: Instrumented puncture test*

© International Organization for Standardization, 1988 •

Printed in Switzerland

Plastics film and sheeting — Determination of impact resistance by the free-falling dart method

Part 1: Staircase methods

1 Scope

1.1 This part of ISO 7765 specifies methods for the determination of the energy that causes plastics film and sheet less than 1 mm in thickness to fail under specified conditions of impact of a free-falling dart from a specified height that would result in failure of 50 % of the specimens tested.

1.2 Two methods of test are described.

1.2.1 Method A employs a dart with a 38 mm \pm 1 mm diameter hemispherical head dropped from a height of 0,66 m \pm 0,01 m. This method may be used for materials whose impact resistance requires masses of about 0,05 kg to about 2 kg to fracture them.

1.2.2 Method B employs a dart with a 50 mm \pm 1 mm diameter hemispherical head dropped from a height of 1,50 m \pm 0,01 m. Its range of applicability is from about 0,3 kg to about 2 kg.

1.3 The measurement technique is the staircase method. A uniform missile mass increment is employed during testing and the missile weight is decreased or increased by the uniform increment after test of each specimen, depending upon the result (failure or no failure) observed for the specimen.

2 Normative references

The following standards contain provisions which, through reference in this text, constitute provisions of this part of ISO 7765. At the time of publication, the editions indicated were valid. All standards are subject to revision, and parties to agreements based on this part of ISO 7765 are encouraged to investigate the possibility of applying the most recent editions of the standards listed below. Members of IEC and ISO maintain registers of currently valid International Standards.

ISO 291 : 1977, *Plastics — Standard atmospheres for conditioning and testing.*

ISO 4591 : 1979, *Plastics — Film and sheeting — Determination of average thickness of a sample and average thickness and yield of a roll, by gravimetric techniques (gravimetric thickness).*

ISO 4593 : 1979, *Plastics — Film and sheeting — Determination of thickness by mechanical scanning.*

3 Significance

3.1 Methods A and B are used to establish the mass of the dart causing 50 % of the specimens to fail under the conditions specified. Data obtained by one method cannot be compared directly with those from the other method, nor with those obtained from tests employing different conditions of missile velocity, missile impinging surface diameter, effective specimen diameter, and specimen thickness. The results obtained with particular values of these test variables are highly dependent on the method of fabrication of the film or sheeting.

3.2 The results obtained by methods A and B are greatly influenced by the quality of the material under test. The confidence limits of data obtained by this procedure can, therefore, vary significantly, depending on the sample quality, uniformity of gauge, die marks, contaminants, etc.

3.3 Methods A and B have been found useful for specification purposes. Correlation between test results and field performance can usually be established.

3.4 The impact resistance of film and sheeting, while partly dependent on thickness, has no simple correlation with sample thickness. Hence, impact values cannot be normalized over a range of thicknesses without producing misleading data as to the actual impact resistance of the material. Data from these methods are comparable only for sample sets that vary by no more than \pm 10 % from the nominal or average thickness of the specimens tested.

4 Definitions

For the purposes of this part of ISO 7765, the following definitions apply.

ISO 7765-1 : 1988 (E)

4.1 Impact failure mass: The missile mass, estimated statistically, at which 50 % of the specimens would fail in the specified test.

4.2 missile mass: The total of the masses of the dart, the incremental weights attached and the locking collar.

5 Apparatus

The apparatus shall be constructed essentially as shown in figure 1, using the following components:

5.1 Specimen clamp, consisting of a two-piece annular clamp having an inside diameter of $125 \text{ mm} \pm 2 \text{ mm}$. The lower or stationary half of the clamp shall be mounted rigidly so that the plane of the specimen is horizontal. The upper or movable part of the clamp shall be designed to maintain positive and plane contact with the lower part of the clamp when in position. The clamps shall be provided with suitable means of maintaining sufficient contact to hold the test specimen firmly in place during the test.

NOTE — Pneumatically operated clamps have been successfully employed.

5.1.1 Rubber-like gaskets may be affixed to the specimen contact surfaces of both clamps to provide a cushion to minimize thickness variation effects. Rubber gasketing $3 \text{ mm} \pm 1 \text{ mm}$ thick, of 50 to 60 Shore A durometer hardness, $125 \text{ mm} \pm 2 \text{ mm}$ in inside diameter and $150 \text{ mm} \pm 3 \text{ mm}$ in outside diameter has been found satisfactory for this purpose.

5.1.2 Slippage of material greater than $0,10 \text{ mm}$ in thickness may be minimized or eliminated by securing crocus cloth or 50 D garnet abrasive paper to the clamps, or to the rubber-like gaskets if these are used, with double-faced adhesive tape so that the abrasive surface is in direct contact with the material to be tested. There shall be sufficient clamping force to eliminate detectable slippage. Other means of reducing slippage such as additional clamping devices or positive clamping surfaces may be used provided that the test specimen is not weakened at the inside wall of the specimen clamps and that the effective diameter of $125 \text{ mm} \pm 2 \text{ mm}$ of the test specimen is not changed.

5.2 Electromagnet, capable of supporting a 2 kg mass, for use in holding and releasing the dart assembly. It shall be equipped with a centring device to ensure reproducible drop and a suitable source of electric power which may be interrupted to energize and de-energize the electromagnet. Alternatively, the use of air-operated or other mechanical release mechanisms is permitted, provided uniform and reproducible release is obtained.

5.3 Positioning device, to hold the dart at a drop height of $0,66 \text{ m} \pm 0,01 \text{ m}$ (method A) and $1,50 \text{ m} \pm 0,01 \text{ m}$ (method B) from the impinging surface of the dart head to the surface of the test specimen. The dart shall be positioned vertically above the centre of the test specimen.

5.4 Micrometer, accurate to $\pm 0,0025 \text{ mm}$ in the range from $0,0025 \text{ mm}$ to 1 mm , for measuring specimen thickness.

5.5 Cushioning and shielding devices, to protect personnel and to avoid damaging the impinging surface of the dart.

5.6 Collar, with inside diameter of approximately 7 mm and with set screw for securing collar to dart shaft.

5.7 Darts, for methods A and B, with hemispherical heads, each fitted with a $6,5 \text{ mm} \pm 0,1 \text{ mm}$ diameter shaft at least 115 mm long to accommodate removable incremental weights. The mass of each dart shall be known to an accuracy of $\pm 0,5 \%$. Dart head surfaces shall be free of nicks, scratches, or other irregularities. The shaft shall be attached to the centre of the flat surface of the head with its longitudinal axis perpendicular to the surface. The shaft shall be made of material that is not magnetic and shall have a steel tip $12,5 \text{ mm} \pm 0,2 \text{ mm}$ long at the end held by the electromagnet.

5.7.1 For method A, the dart head shall be $38 \text{ mm} \pm 1 \text{ mm}$ in diameter. It may be constructed of smooth, polished aluminium, phenolic plastic, or other low-density material of similar hardness.

5.7.2 For method B, the dart head shall be $50 \text{ mm} \pm 1 \text{ mm}$ in diameter. It may be constructed of smooth, polished stainless steel or other material of similar durability.

5.8 Incremental weights, made of stainless steel or brass and cylindrical in shape. Each shall have a centre hole that allows free fit on to a shaft of $6,5 \text{ mm} \pm 0,1 \text{ mm}$ in diameter.

The thickness of each shall be adjusted to obtain the appropriate mass within $\pm 0,5 \%$. Suggested sets of weights are as follows.

5.8.1 For method A, 30 mm diameter weights.

Number	Mass, g
2 or more	5
8	15
8	30
8	60

5.8.2 For method B, 45 mm diameter weights.

Number	Mass, g
2 or more	15
8	45
8	90

5.8.3 Optionally, additional weights, each $120 \text{ g} \pm 0,5 \%$ for method A or $180 \text{ g} \pm 0,5 \%$ for method B, may be constructed for use if it is necessary to extend the missile mass beyond that attainable when using all weights in the standard set.

6 Test specimens

6.1 The test specimens shall be large enough to extend outside the specimen clamp gaskets at all points. The specimens shall be taken from the material to be tested in a manner repre-

sentative of sound sampling practice, unless such sampling constitutes a variable under study. The quantity of material shall be sufficient to provide at least 30 test specimens.

6.2 The specimens shall be free of pinholes, wrinkles, folds, or other obvious imperfections, unless such imperfections constitute variables under study.

6.3 The specimen thickness shall be within $\pm 10\%$ of the nominal value.

7 Conditioning and testing atmospheres

7.1 Condition the test specimen at $23\text{ }^{\circ}\text{C} \pm 2\text{ }^{\circ}\text{C}$ and $50\% \pm 5\%$ relative humidity for not less than 40 h prior to testing for materials that require conditioning. In cases of dispute, the tolerances shall be $\pm 1\text{ }^{\circ}\text{C}$ and $\pm 2\%$ relative humidity.

7.2 The test shall be carried out in the same atmospheric conditions as the conditioning.

8 Procedure

8.1 Determination of thickness

Determine the thickness of the material being tested by the method specified in ISO 4591 or ISO 4593.

NOTE — ISO 4593 is not suitable for use with embossed film and sheeting.

8.2 Preparation of apparatus

8.2.1 Set up the apparatus for testing by method A or by method B.

8.2.2 Energize the electromagnet and position the specified dart (see 5.7) vertically with the steel shaft tip inserted in the magnet adapter. Adjust the drop height (the vertical distance from the plane of a clamped specimen to the bottom surface of the dart head) to $0,66\text{ m} \pm 0,01\text{ m}$ for method A or to $1,50\text{ m} \pm 0,01\text{ m}$ for method B.

CAUTION — For safety reasons, remove the dart while making position adjustments.

8.2.3 With a trial test specimen clamped between the specimen clamps and with no added weights on the dart, de-energize the electromagnet to release the dart and observe the point at which the dart impacts the specimen, catching the dart after it bounces off the surface of the specimen. If necessary, adjust the electromagnet position so that, in repeated trials, the dart reproducibly impacts the centre of the clamped portion of the specimen.

8.2.4 Check the apparatus periodically to make sure specimen slippage is not occurring during testing. If slippage occurs, reject the results. The likelihood of slippage increases with increasing dart mass and with increasing drop height, and is greater with some materials than with others. Slippage may be checked conveniently during routine testing of a sample at a missile mass wherein both failures and non-failures are being observed. Either of the following procedures is effective.

8.2.4.1 Before dropping the missile on a clamped specimen, draw a circle on the material using a marker pen in contact with the inside wall of the upper clamp. Apply only the pressure of the pen itself to the material.

CAUTION — For safety reasons, remove the dart while drawing the circle.

After the dart is dropped and prior to removing the specimen, draw another circle using a ball-point pen of another colour. Distinct double lines at any point on the circumference show that slippage has occurred.

8.2.4.2 If crocus cloth or sandpaper is affixed to the gaskets to provide greater gripping, determine slippage simply by inspecting the clamped film area after impact for evidence of scratch marks produced as slippage occurred.

8.3 Staircase testing (see 1.3)

8.3.1 Select method A or method B for use, as required by the relevant material specification or as agreed between the interested parties.

8.3.2 Measure and record the average thickness of the test specimens in the area of impact to the nearest $0,0025\text{ mm}$ (see 8.1).

8.3.3 Select a missile mass near the expected impact failure mass. Add the necessary number of incremental weights onto the dart shaft and put the locking collar into place so that the weights are held securely in place.

8.3.4 Select a missile mass increment Δm appropriate to the impact strength of the sample. The value chosen for Δm should be such that three to six (but at least three) missile masses will be employed in the determination. A Δm value equal to some 5% to 15% of m_f , the impact failure mass, is usually appropriate.

8.3.5 Place the first test specimen over the bottom part of the clamp, making sure that it is uniformly flat, free of folds, and covers the gasket at all points. Clamp in place with the top part of the annular clamp.

8.3.6 Energize the electromagnet and put the dart into position. De-energize the magnet to release the dart. If the dart bounces off the specimen surface, catch the dart after it bounces to prevent both multiple impact with the specimen surface and damage to the hemispherical contact surface of the dart resulting from impact.

8.3.7 Examine the test specimen for any evidence of slippage. If slippage occurs, reject the results for this specimen.

8.3.8 Examine the specimen to determine whether it has or has not failed. Failure is defined as any break through the specimen that can be observed readily by feeling or by viewing the specimen under back-lighting conditions. Record the results on a form such as that shown in figure 2, using an o to denote non-failure and an x to denote failure.

ISO 7765 : 1988 (E)

8.3.9 If the first specimen fails, decrease the missile mass by Δm . If the first specimen does not fail, increase the missile mass by Δm . Continue testing successive specimens, decreasing or increasing the missile mass by Δm between drops depending upon whether the preceding specimen did or did not fail.

8.3.10 After 20 specimens have been tested, count the total number of failures N . If $N = 10$ at this point, testing is complete. If not, complete testing as follows.

8.3.10.1 If $N < 10$, continue testing additional specimens until $N = 10$, then stop testing.

8.3.10.2 If $N > 10$, continue testing additional specimens until the total number of non-failures (o — see 8.3.8) reaches 10, then stop testing.

9 Calculation

Calculate the impact failure mass m_f , in grams, as follows:

$$m_f = m_0 + \Delta m \left(\frac{A}{N} - 0,5 \right)$$

where

m_0 is the lowest missile mass, in grams, at which failure was found for the k mass steps;

Δm is the uniform mass increment, in grams, used;

$$A = \sum_{i=1}^k n_i z_i$$

where

n_i is the number of test specimens for which failure occurred at a mass m_i ,

z_i is the number of mass increments from m_0 to m_i (z for m_0 is 0);

$$N = \sum_{i=1}^k n_i \quad (\text{i.e. the sum of failed specimens}).$$

An example of the calculation of impact failure mass is presented in figure 2.

10 Test report

10.1 The test report shall include the following particulars:

- a) a reference to this part of ISO 7765;
- b) a complete identification and description of the material tested, including type, source, manufacturer's code, principal dimensions, and previous history;
- c) the thickness of the material tested and the range of thicknesses of the specimens tested;
- d) the test conditions and conditioning procedures, if applicable;
- e) the method used (A or B);
- f) the impact failure mass, to the nearest 1 g.

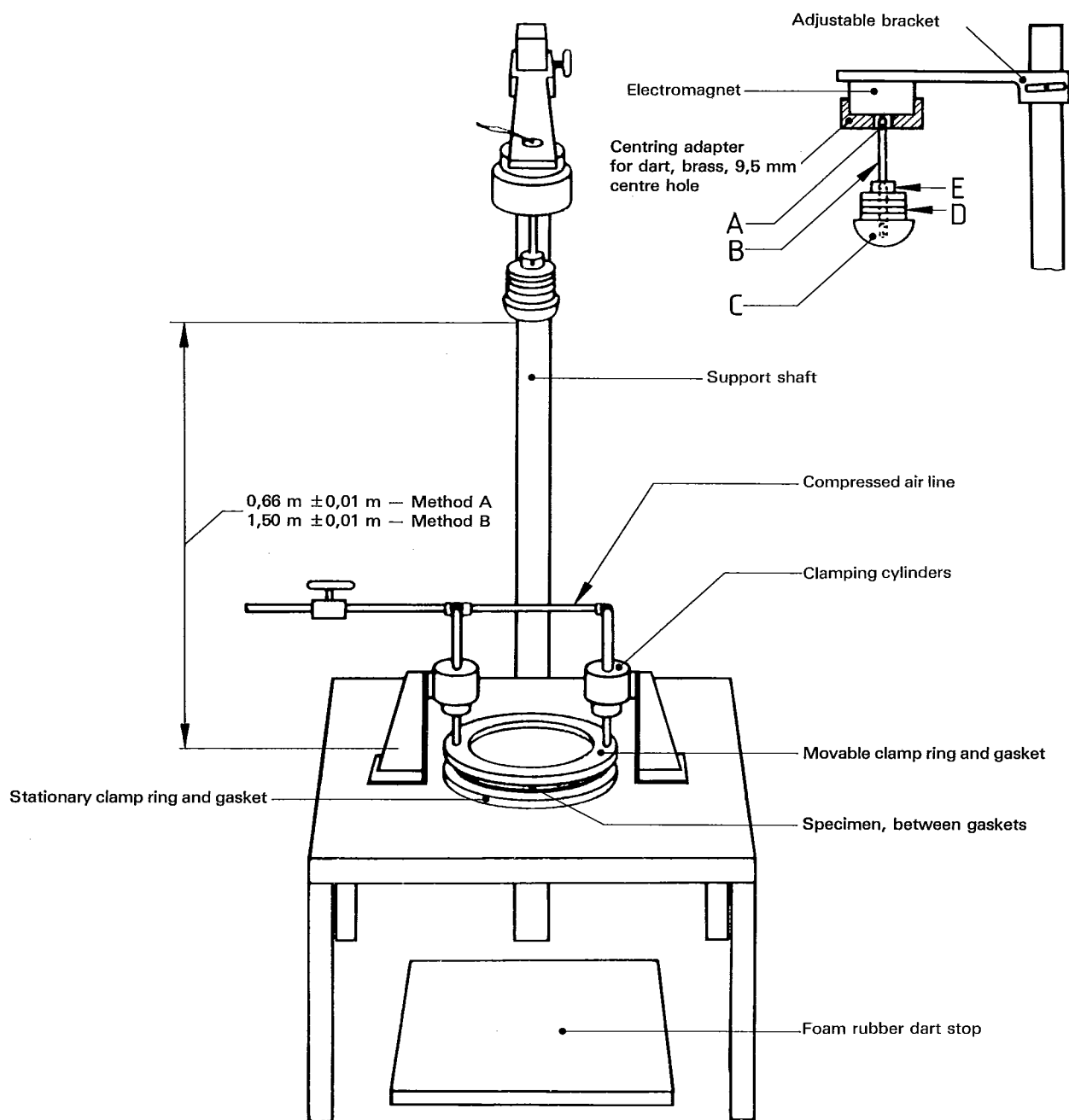

Key

- | | | | |
|---|---|---|-------------------|
| A | Steel shaft tip 6,5 mm OD by 13,5 mm long | D | Removable weights |
| B | Dart shaft: 6,5 mm OD and at least 115 mm long,
12,5 mm long at bottom | E | Collar and screw |
| C | Hemispherical head: Method A — 38 mm \pm 1 mm in diameter;
Method B — 50 mm \pm 1 mm in diameter | | |

Figure 1 — Apparatus for free-falling dart impact test

(Courtesy of ASTM)

ISO 7765 : 1988 (E)

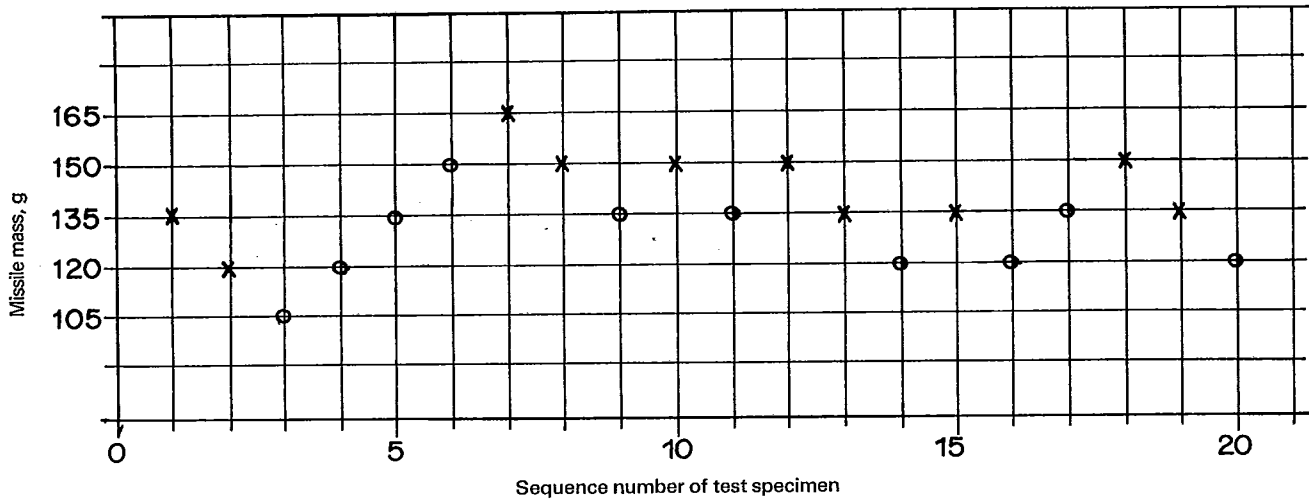

x = failure
o = non failure

$$N = 10$$

$$A = 15$$

$$m_0 = 120 \text{ g}$$

$$\Delta m = 15 \text{ g}$$

$$m_f = m_0 + \Delta m \left(\frac{A}{N} - 0,5 \right)$$

$$= 120 + 15 \left(\frac{15}{10} - 0,5 \right)$$

$$= 120 + 15 (1,5 - 0,5)$$

$$= 135 \text{ g}$$

$m_0 + (i - 1)\Delta m$	n_i	z_i	$n_i z_i$
120	1	0	0
135	4	1	4
150	4	2	8
165	1	3	3

Figure 2 — Calculation of impact failure mass by the staircase procedure

UDC [678.5/.8]-416 : 620.178.7

Descriptors: plastics, films, plastic sheets, tests, impact tests, test equipment.

Price based on 6 pages