

---

---

**Dentistry — Rotary diamond  
instruments —**

**Part 2:  
Discs**

*Médecine bucco-dentaire — Instruments rotatifs diamantés —  
Partie 2: Disques*



**COPYRIGHT PROTECTED DOCUMENT**

© ISO 2011

All rights reserved. Unless otherwise specified, no part of this publication may be reproduced or utilized in any form or by any means, electronic or mechanical, including photocopying and microfilm, without permission in writing from either ISO at the address below or ISO's member body in the country of the requester.

ISO copyright office  
Case postale 56 • CH-1211 Geneva 20  
Tel. + 41 22 749 01 11  
Fax + 41 22 749 09 47  
E-mail [copyright@iso.org](mailto:copyright@iso.org)  
Web [www.iso.org](http://www.iso.org)

Published in Switzerland

# Contents

Page

Foreword .....	iv
<b>1 Scope .....</b>	<b>1</b>
<b>2 Normative references .....</b>	<b>1</b>
<b>3 Terms, definitions and symbols .....</b>	<b>1</b>
3.1 Terms and definitions .....	1
3.2 Symbols .....	2
<b>4 Requirements .....</b>	<b>3</b>
4.1 Dimensions of discs .....	3
4.2 Preferred sizes .....	4
4.3 Disc blank .....	4
4.4 Run-out .....	5
<b>5 Examples of specific shapes for discs .....</b>	<b>6</b>
5.1 Disc, very thin, peripheral and rim cutting .....	6
5.2 Disc, thin, peripheral and rim cutting .....	6
5.3 Disc, thick, peripheral and rim cutting .....	7
5.4 Disc, thin, peripheral and proximal cutting .....	8
5.5 Disc, standard, peripheral and proximal cutting .....	9
<b>6 Manufacturer's information .....</b>	<b>10</b>
6.1 Labelling on the package .....	10
6.2 Published media .....	11
<b>Bibliography .....</b>	<b>12</b>

## Foreword

ISO (the International Organization for Standardization) is a worldwide federation of national standards bodies (ISO member bodies). The work of preparing International Standards is normally carried out through ISO technical committees. Each member body interested in a subject for which a technical committee has been established has the right to be represented on that committee. International organizations, governmental and non-governmental, in liaison with ISO, also take part in the work. ISO collaborates closely with the International Electrotechnical Commission (IEC) on all matters of electrotechnical standardization.

International Standards are drafted in accordance with the rules given in the ISO/IEC Directives, Part 2.

The main task of technical committees is to prepare International Standards. Draft International Standards adopted by the technical committees are circulated to the member bodies for voting. Publication as an International Standard requires approval by at least 75 % of the member bodies casting a vote.

Attention is drawn to the possibility that some of the elements of this document may be the subject of patent rights. ISO shall not be held responsible for identifying any or all such patent rights.

ISO 7711-2 was prepared by Technical Committee ISO/TC 106, *Dentistry*, Subcommittee SC 4, *Dental instruments*.

This second edition cancels and replaces the first edition (ISO 7711-2:1992), which has been technically revised. The changes are the following:

- a) inclusion of general requirements for all discs used commonly in the dental laboratory;
- b) bore diameter for unmounted discs harmonized with other International Standards to 1,7 mm;
- c) replacement of inner diameter of diamond covered area by width of diamond coating;
- d) addition of labelling requirements.

ISO 7711 consists of the following parts, under the general title *Dentistry — Rotary diamond instruments*:

- *Part 1: Dimensions, requirements, marking and packaging*<sup>1)</sup>
- *Part 2: Discs*
- *Part 3: Grit sizes, designation and colour code*

---

1) The intent is for the main element of the title of Parts 1 and 3 to be aligned, upon revision, with the main element of the title of Part 2.

# Dentistry — Rotary diamond instruments —

## Part 2: Discs

### 1 Scope

This part of ISO 7711 specifies requirements for diamond discs used commonly in the dental laboratory for the cutting of dental materials, such as metals, ceramics, plastics or gypsum.

In addition, this part of ISO 7711 selects five specific shapes with their specific dimensions.

### 2 Normative references

The following referenced documents are indispensable for the application of this document. For dated references, only the edition cited applies. For undated references, the latest edition of the referenced document (including any amendments) applies.

ISO 1797-1, *Dentistry — Shanks for rotary instruments — Part 1: Shanks made of metals*

ISO 1942, *Dentistry — Vocabulary*

ISO 6892-1, *Metallic materials — Tensile testing — Part 1: Method of test at room temperature*

ISO 7711-3, *Dentistry — Diamond rotary instruments — Part 3: Grit sizes, designation and colour code*

ISO 8325:2004, *Dentistry — Test methods for rotary instruments*

### 3 Terms, definitions and symbols

#### 3.1 Terms and definitions

For the purposes of this document, the terms and definitions given in ISO 1942 and ISO 7711-3 and the following apply.

##### 3.1.1

##### **diamond disc**

disc partially or totally covered with diamond grit

##### 3.1.2

##### **disc**

working part of a rotary instrument with flat round shape, which is intended to be mounted on a shank intended for use in the dental laboratory for the cutting of dental materials, such as metals, ceramics, plastics or gypsum

NOTE For shank, see Figure 1.

##### 3.1.3

##### **disc blank**

disc plate without diamond grit

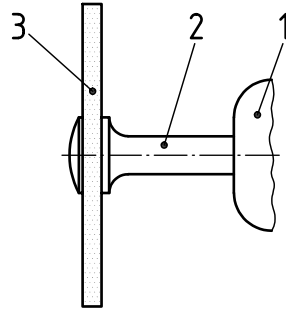

**Key**

- 1 handpiece
- 2 mandrel
- 3 disc

**Figure 1 — Mounting of disc**

**3.2 Symbols**

For the purposes of this document, the following symbols apply (see Figures 2 and 3).

- $b$  width of diamond coating;
- $d_1$  outer diameter;
- $d_2$  bore diameter;
- $l_1$  thickness of disc blank with diamond grit;
- $l_2$  thickness of disc blank;
- $l_3$  protruding length (see Figure 3);
- $rr$  circular run-out — radial;
- $rx$  circular run-out — axial (lateral).

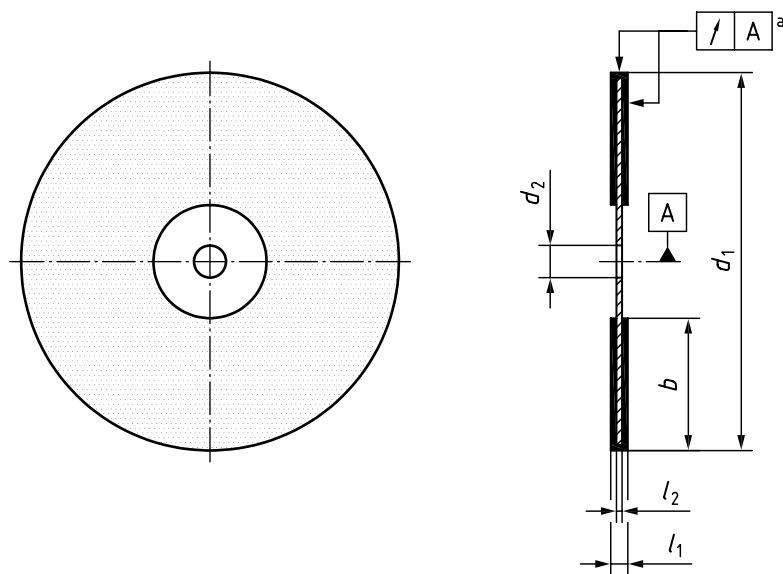

<sup>a</sup> The symbol for the circular run-out is the same for the radial run-out,  $rr$ , and for the axial run-out,  $rx$ .

**Figure 2 — Dimensions for discs**

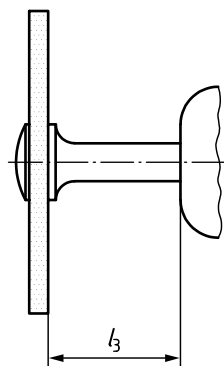

Figure 3 — Specification of protruding length

## 4 Requirements

### 4.1 Dimensions of discs

#### 4.1.1 Bore diameter

The bore diameter for discs,  $d_2$ , shall be  $1,7^{+0,05}_0$  mm.

#### 4.1.2 Thickness of disc blank

The thickness of disc blank,  $l_2$ , shall be at least 0,05 mm.

#### 4.1.3 Outer diameter and tolerance

The outer diameter of the disc,  $d_1$ , and the tolerances for the outer diameter shall be as specified in Table 1.

The tolerances for the width of diamond coating shall be as specified in Table 1.

Table 1 — Outer diameter and tolerances

Dimensions in millimetres

Nominal size	Outer diameter $d_1$	Tolerances for outer diameter of disc $d_1$	Tolerances for the width of diamond coating $b$
65 to 100	6,5 to 10	0/+ 0,2	±0,3
> 100 to 180	> 10 to 18	0/+ 0,3	
> 180 to 250	> 18 to 25	0/+ 0,4	±0,5
> 250	> 25	0/+ 0,5	

#### 4.1.4 Width of diamond coating

The width of diamond coating,  $b$ , of the disc is at the discretion of the manufacturer.

Tolerances for the width of diamond coating shall be in accordance with Table 1.

#### 4.1.5 Thickness of disc blank with diamond grain

The tolerance for the thickness of disc blank with diamond grain,  $l_1$ , shall be as specified in Table 2.

The thickness may vary either on one side or on both sides of the disc in the area covered with diamond grain.

**Table 2 — Tolerance of thickness of disc blank with diamond grain**

Dimensions in millimetres

Disc plate with diamond grain $l_1$	Tolerance
$\leq 0,3$	$\pm 0,03$
$> 0,3$	$\pm 0,04$

## 4.2 Preferred sizes

### 4.2.1 Preferred outer diameters

The preferred ISO sizes for the outer diameter (disc sizes) for discs are specified in Table 3. Discs with other outer diameters are optional.

**Table 3 — Preferred ISO sizes**

Preferred nominal size Outer diameter
160
180
200
220

### 4.2.2 Preferred thickness of disc blank with diamond grit

The preferred thickness of disc blank with diamond grit,  $l_1$ , is specified in Table 4. Discs with other thickness of disc blank with diamond grit are optional.

**Table 4 — Preferred thickness of disc blank with diamond grit**

Dimensions in millimetres

Preferred thickness of disc blank with diamond grit
0,15
0,20
0,25
0,30
0,45

## 4.3 Disc blank

### 4.3.1 Material for disc blank

The material used for the disc blank shall be stainless steel.



The type of steel and the treatment of the steel is at the discretion of the manufacturer.

#### 4.3.2 Minimum proof strength of disc blank

The minimum proof strength,  $R_{p0,2}$ , of the disc blank shall be as specified in Table 5.

**Table 5 — Minimum proof strength,  $R_{p0,2}$ , of disc blank**

Thickness of disc blank $l_2$ mm	Minimum proof strength $R_{p0,2}$ MPa
$\leq 0,1$	1 000
$> 0,1$	800

The proof strength shall be tested in accordance with ISO 6892-1.

#### 4.3.3 Diamond covering

The grain size distribution and the colour code used for the diamond covering of the disc shall be in accordance with ISO 7711-3.

### 4.4 Run-out

#### 4.4.1 Mounting of disc

The disc shall be mounted on a mandrel. The mandrel shall be inserted into a dental or technical handpiece.

In order to limit the run-out and the bending of the mandrel on which the disc is mounted, the recommended protruding shank length,  $l_3$  (see Figure 3), is specified in Table 6.

NOTE 1 The protruding length,  $l_3$ , is recommended, but not mandatory. It is not associated with the run-out measurement.

NOTE 2 For the recommended rotational speed of the disc, see the manufacturer's instructions for use.

**Table 6 — Recommended protruding length,  $l_3$**

Dimensions in millimetres

Shank	$l_3$
ISO 1797-1	$\pm 1$
Type 1	10
Type 2	15

#### 4.4.2 Circular run-out — Radial

The circular run-out — radial,  $r_r$ , of the mounted discs shall be at a maximum of 0,15 mm.

The measuring point is the middle of the disc at the periphery. For more details, see ISO 8325:2004, Figure 1.

The circular run-out — radial shall be tested in accordance with ISO 8325:2004, 5.8.

#### 4.4.3 Circular run-out — Axial

The circular run-out — axial (lateral),  $r_x$ , of the mounted discs shall be at a maximum of 0,15 mm.

The measuring point is at the top side of the disc at the periphery.

The circular run-out — axial shall be tested with a suitable measuring method.

## 5 Examples of specific shapes for discs

### 5.1 Disc, very thin, peripheral and rim cutting

5.1.1 These discs shall comply with Figure 4 and Table 7.

5.1.2 Minimum proof strength,  $R_{p0,2} \geq 1\ 000$  MPa.

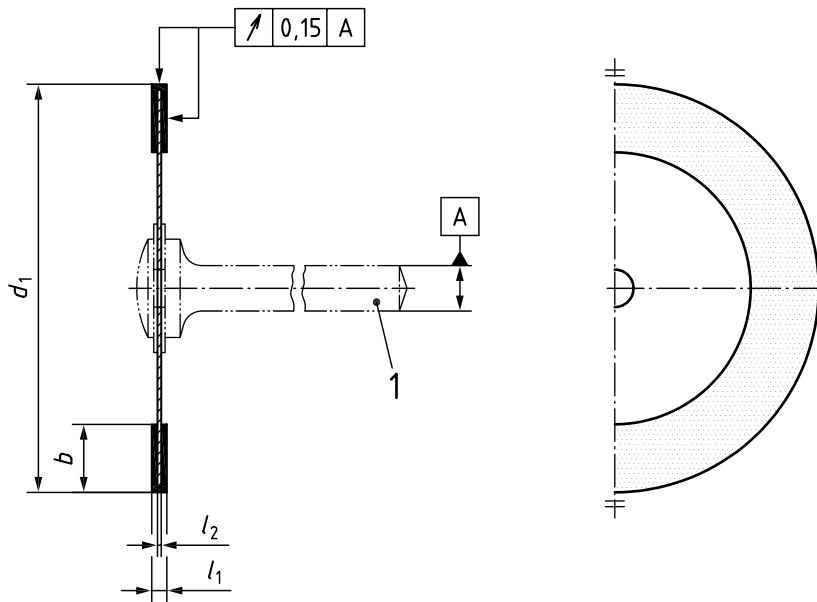

**Key**

1 shank in accordance with ISO 1797-1

**Figure 4 — Disc, very thin, peripheral and rim cutting**

**Table 7 — Dimensions and tolerances for discs, very thin, peripheral and rim cutting**

Dimensions in millimetres

Nominal size	$d_1$		$b$		$l_1$		$l_2$	
		tol.		tol.		tol.		tol.
140	14	0 +0,3	2	± 0,3	0,15	± 0,03	0,05	± 0,005
160	16		3					
180	18		3					
200	20	3	± 0,5					
220	22	3						

### 5.2 Disc, thin, peripheral and rim cutting

5.2.1 These discs shall comply with Figure 5 and Table 8.

5.2.2 Minimum proof strength,  $R_{p0,2} \geq 1\,000$  MPa.

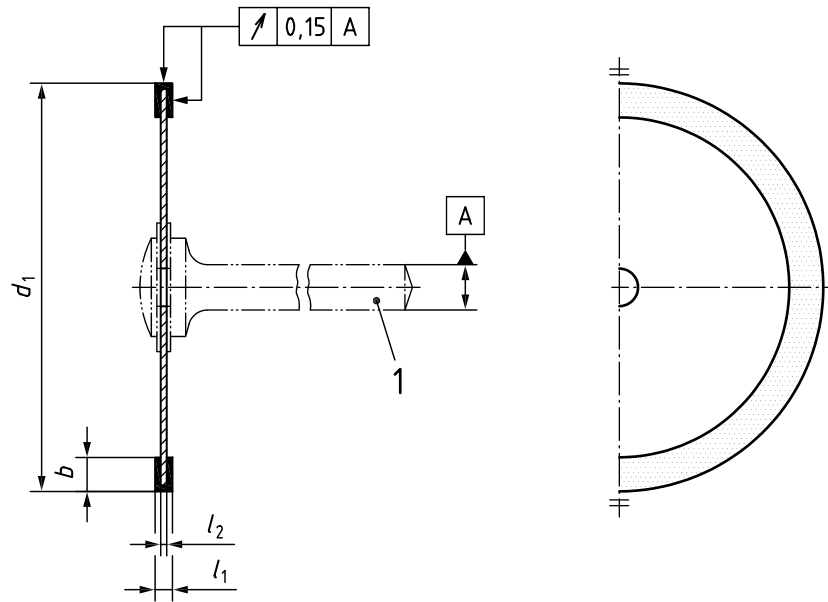

**Key**

1 shank in accordance with ISO 1797-1

**Figure 5 — Disc, thin, peripheral and rim cutting**

**Table 8 — Dimensions and tolerances for discs, thin, peripheral and rim cutting**

Dimensions in millimetres

Nominal size	$d_1$		$b$		$l_1$		$l_2$	
		tol.		tol.		tol.		tol.
160	16	0 +0,3	1,5	± 0,3	0,3	± 0,03	0,1	± 0,01
180	18		1,5					
200	20	1,5						
220	22	1,5						
250	25	2						
		0 +0,4		± 0,5				

**5.3 Disc, thick, peripheral and rim cutting**

5.3.1 These discs shall comply with Figure 6 and Table 9.

5.3.2 Minimum proof strength,  $R_{p0,2} \geq 800$  MPa.

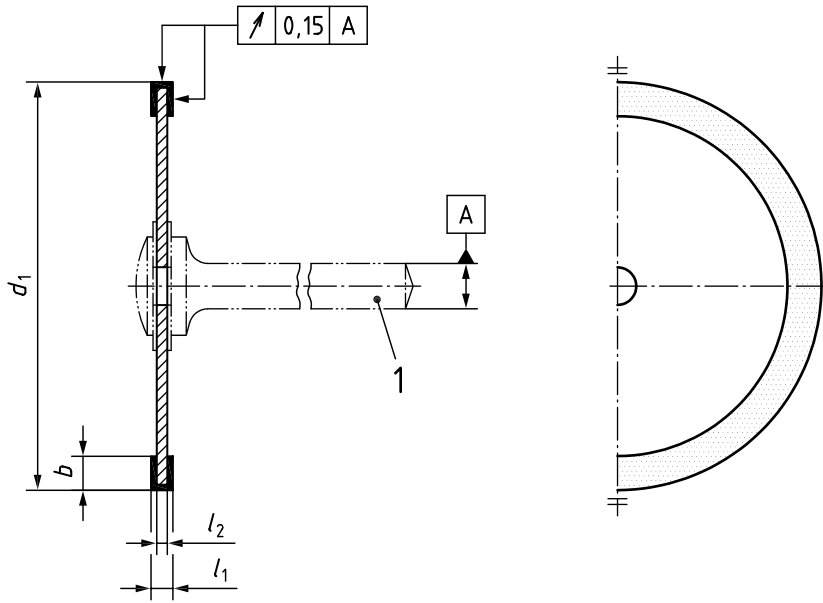

**Key**

1 shank in accordance with ISO 1797-1

**Figure 6 — Disc, thick, peripheral and rim cutting**

**Table 9 — Dimensions and tolerances for discs, thick, peripheral and rim cutting**

Dimensions in millimetres

Nominal size	$d_1$		$b$		$l_1$		$l_2$	
		tol.		tol.		tol.		tol.
160	16	0 +0,3	1,5	± 0,3	0,55	± 0,04	0,3	± 0,02
180	18		1,5					
200	20	1,5						
220	22	0 +0,4	1,5	± 0,5				
250	25		2					

**5.4 Disc, thin, peripheral and proximal cutting**

5.4.1 These discs shall comply with Figure 7 and Table 10.

5.4.2 Minimum proof strength,  $R_{p0,2} \geq 1\ 000$  MPa.

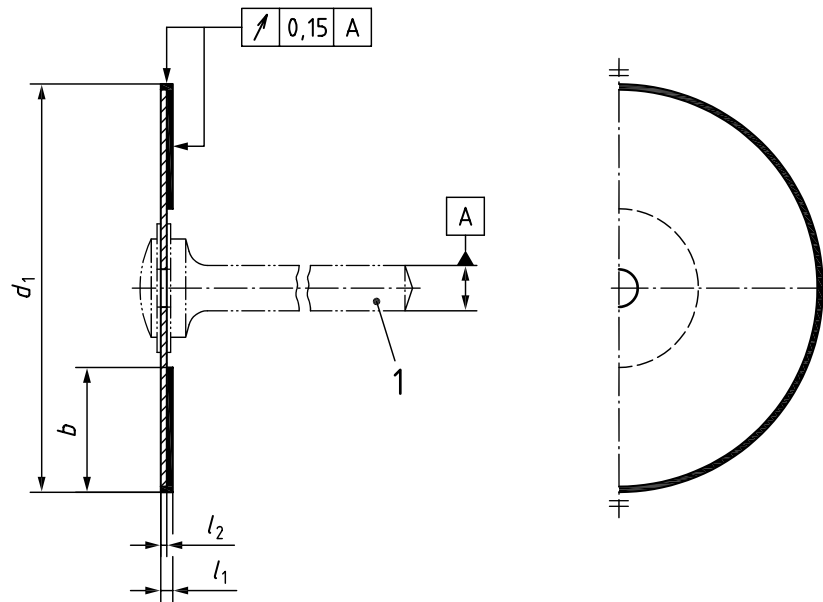

**Key**

1 shank in accordance with ISO 1797-1

**Figure 7 — Disc, thin, peripheral and proximal cutting**

**Table 10 — Dimensions and tolerances for discs, thin, peripheral and proximal cutting**

Dimensions in millimetres

Nominal size	$d_1$		$b$		$l_1$		$l_2$	
		tol.		tol.		tol.		tol.
160	16	0 +0,3	4,5	± 0,3	0,2	± 0,03	0,1	± 0,01
180	18		5,5					
200	20	6,5						
220	22	0 +0,4	7,5	± 0,5				
250	25		9					

**5.5 Disc, standard, peripheral and proximal cutting**

**5.5.1** These discs shall comply with Figure 8 and Table 11.

**5.5.2** Minimum proof strength,  $R_{p0,2} \geq 800$  MPa.

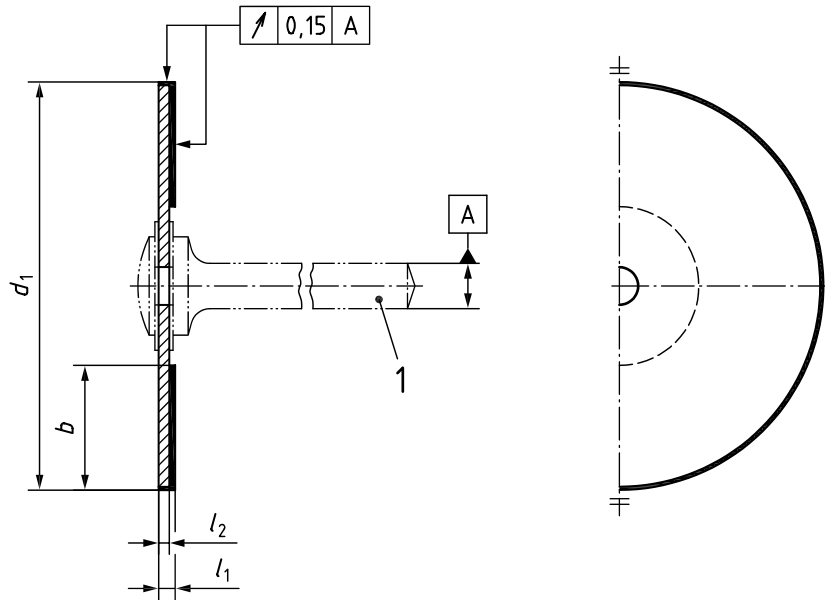

**Key**

1 shank in accordance with ISO 1797-1

**Figure 8 — Disc, standard, peripheral and proximal cutting**

**Table 11 — Dimensions and tolerances for disc, standard, peripheral and proximal cutting**

Dimensions in millimetres

Nominal size	$d_1$		$b$		$l_1$		$l_2$	
		tol.		tol.		tol.		tol.
180	18	$0^{+0,3}$	5,5	$\pm 0,3$	0,45	$\pm 0,04$	0,3	$\pm 0,02$
200	20	$0^{+0,4}$	6,5	$\pm 0,5$				
220	22		7,5					
250	25		9					

**6 Manufacturer’s information**

**6.1 Labelling on the package**

The labelling on the package of discs shall contain at least the following information:

- a) name and/or trademark of manufacturer;
- b) type of shank;
- c) identification of shape and/or grit size (e.g. as a part of a reference designation, REF);
- d) nominal size (in parts of 1/10 mm);
- e) lot number.

## 6.2 Published media

The following information shall be given in the handbook or other published media:

- a) thickness of disc blank with diamond grit;
- b) width of diamond coating.

## Bibliography

- [1] ISO 1101, *Geometrical Product Specifications (GPS) — Geometrical tolerancing — Tolerances of form, orientation, location and run-out*
- [2] ISO 13295, *Dentistry — Mandrels for rotary instruments*





