**Anodizing of aluminium and its alloys —
Measurement of specular reflectance
and specular gloss of anodic oxidation
coatings at angles of 20°, 45°, 60° or 85°**

*Anodisation de l'aluminium et de ses alliages — Mesurage des
caractéristiques de réflectivité et de brillant spéculaires des couches
anodiques à angle fixe de 20°, 45°, 60° ou 85°*



Reference number
ISO 7668:2010(E)

© ISO 2010

PDF disclaimer

This PDF file may contain embedded typefaces. In accordance with Adobe's licensing policy, this file may be printed or viewed but shall not be edited unless the typefaces which are embedded are licensed to and installed on the computer performing the editing. In downloading this file, parties accept therein the responsibility of not infringing Adobe's licensing policy. The ISO Central Secretariat accepts no liability in this area.

Adobe is a trademark of Adobe Systems Incorporated.

Details of the software products used to create this PDF file can be found in the General Info relative to the file; the PDF-creation parameters were optimized for printing. Every care has been taken to ensure that the file is suitable for use by ISO member bodies. In the unlikely event that a problem relating to it is found, please inform the Central Secretariat at the address given below.



COPYRIGHT PROTECTED DOCUMENT

© ISO 2010

All rights reserved. Unless otherwise specified, no part of this publication may be reproduced or utilized in any form or by any means, electronic or mechanical, including photocopying and microfilm, without permission in writing from either ISO at the address below or ISO's member body in the country of the requester.

ISO copyright office
Case postale 56 • CH-1211 Geneva 20
Tel. + 41 22 749 01 11
Fax + 41 22 749 09 47
E-mail copyright@iso.org
Web www.iso.org

Published in Switzerland

Contents

Page

Foreword	iv
Introduction	v
1 Scope	1
2 Terms and definitions	1
3 Principle	1
4 Apparatus and geometric conditions	2
5 Optical standards	7
5.1 Reference standards	7
5.2 Working standards	7
6 Preparation and calibration of apparatus	7
7 Measurement of specular reflectance and specular gloss	8
7.1 General	8
7.2 Measurement of specular reflectance	8
7.3 Measurement of specular gloss	8
8 Expression of results	11
8.1 General	11
8.2 Specular reflectance	11
8.3 Specular gloss	11
9 Test report	11
Annex A (normative) Specular reflectance and specular gloss of black glass	12
Bibliography	13

Foreword

ISO (the International Organization for Standardization) is a worldwide federation of national standards bodies (ISO member bodies). The work of preparing International Standards is normally carried out through ISO technical committees. Each member body interested in a subject for which a technical committee has been established has the right to be represented on that committee. International organizations, governmental and non-governmental, in liaison with ISO, also take part in the work. ISO collaborates closely with the International Electrotechnical Commission (IEC) on all matters of electrotechnical standardization.

International Standards are drafted in accordance with the rules given in the ISO/IEC Directives, Part 2.

The main task of technical committees is to prepare International Standards. Draft International Standards adopted by the technical committees are circulated to the member bodies for voting. Publication as an International Standard requires approval by at least 75 % of the member bodies casting a vote.

Attention is drawn to the possibility that some of the elements of this document may be the subject of patent rights. ISO shall not be held responsible for identifying any or all such patent rights.

ISO 7668 was prepared by Technical Committee ISO/TC 79, *Light metals and their alloys*, Subcommittee SC 2, *Organic and anodic oxidation coatings on aluminium*.

This second edition cancels and replaces the first edition (ISO 7668:1986), which has been technically revised.

Introduction

Specular reflectance and specular gloss are not unique physical properties of a surface. They vary with the angle of measurement, and with the aperture dimensions that define the incident and the reflected beams, such that measurements of these properties are not independent of the apparatus being used.

The specular reflectance of most surfaces increases with the angle of measurement and accounts for the use of reflectometers with various angles as, for example, for painted surfaces. The specular reflectance characteristics of anodized aluminium, however, do not always behave in the normal manner and, because of its property of double reflection, reflected light comes partly from the film surface and partly from the underlying metal. It is advisable to measure the specular reflectance characteristics at 20°, 45°, 60°, and 85° to obtain a complete understanding of the specular reflectance properties of the anodized surface, and careful thought should be given to which method or methods are most relevant in any particular situation. The specular reflectance of bright-anodized aluminium with a mirror finish is best measured using 45° or 20° geometry.

Anodizing of aluminium and its alloys — Measurement of specular reflectance and specular gloss of anodic oxidation coatings at angles of 20°, 45°, 60° or 85°

1 Scope

This International Standard specifies methods for the measurement of specular reflectance and specular gloss of flat samples of anodized aluminium using geometries of 20° (Method A), 45° (Method B), 60° (Method C) and 85° (Method D); and of specular reflectance by an additional 45° method (Method E) employing a narrow acceptance angle.

The methods described are intended mainly for use with clear anodized surfaces. They can be used with colour-anodized aluminium, but only with similar colours.

2 Terms and definitions

For the purposes of this document, the following terms and definitions apply.

2.1

specular reflectance

ratio of the luminous flux, reflected in the specular direction for a specified source and receptor angle, to the luminous flux of the incident light, normally expressed as a percentage

2.2

specular gloss

ratio of the luminous flux, reflected from an object in the specular direction for a specified source and receptor angle, to the luminous flux reflected from glass with a refractive index of 1,567 in the specular direction

NOTE To set the specular gloss scale, polished black glass with a refractive index of 1,567 is assigned the value of 100 for geometries of 20°, 45°, 60° and 85° (see Table 5). The phenomenon of light reflectance by anodized aluminium is very different to that of black glass and the choice of a black-glass standard is arbitrary and made to allow comparison of different qualities of anodized aluminium.

3 Principle

The specular reflectance and specular gloss of anodized aluminium surfaces are measured under defined conditions using, as required, geometries of 20°, 45°, 60° and 85°.

4 Apparatus and geometric conditions

Usual laboratory apparatus and in particular the following.

4.1 General. Approximate comparisons between surfaces of the same colour can be made, but an accurate measurement requires the combination of light source, photoelectric cell and associated colour filters to give a spectral sensitivity, approximating to the CIE photopic luminous efficiency function, weighted for CIE standard illuminants C (see CIE 38:1977^[1]) or D65.

NOTE Since specular reflection is in general spectrally non-selective, the spectral characteristics of the light source (4.2) and the detector (4.4) need not be critically controlled for the measurement of normal uncoloured anodized surfaces.

4.2 Polychromatic light source and housing, with a lens that directs a parallel, or very slightly converging, beam of light onto the surface under test.

4.3 Means for locating the specimen surface, in the correct position for measurement.

4.4 Receptor housing containing a lens, a receptor aperture and a photoelectric cell, to receive the cone of reflected light.

4.5 Sensitivity control, for setting the photocell current to any desired value on the instrument scale or digital indicator.

4.6 Receptor meter, capable of giving an indication proportional to the light flux passing the receptor aperture within 1 % of the full-scale reading. Spectral corrections are not usually required (see Note to 4.1).

4.7 Geometric conditions

The incident angle, ε_1 , which is the angle between the axis of the incident beam and the perpendicular to the surface under test, shall have the following values and tolerances:

- for Method A: $20^\circ \pm 0,1^\circ$;
- for Method B: $45^\circ \pm 0,1^\circ$;
- for Method C: $60^\circ \pm 0,1^\circ$;
- for Method D: $85^\circ \pm 0,1^\circ$;
- for Method E: $45^\circ \pm 0,1^\circ$.

There shall be no vignetting of rays that lie within the angles specified above.

The axis of the receptor shall, as far as possible, coincide with the mirror image of the axis of the incident beam; the receptor angle, ε_2 , which is the angle between the axis of the receptor and the perpendicular to the surface under test, shall be for all methods such that:

$$|\varepsilon_1 - \varepsilon_2| \leq 0,1^\circ$$

With a flat piece of polished glass or other front-surface mirror in the test panel position, an image of the source shall be formed at the centre of the receptor aperture. The width of the illustrated area of the test panel shall be not less than 10 mm.

The angular dimensions of the receptor apertures shall be measured from the receptor lenses. The dimensions and tolerances of the sources and receptors shall be as indicated in Tables 1 and 2. Figures 1, 2 and 3 give generalized illustrations of these dimensions. Table 1 gives both angles and corresponding dimensions calculated for lenses of a focal length of 50 mm for Methods A, B, C and D. Table 2 gives the angles and aperture dimensions for Method E. The angles are mandatory and the aperture sizes have been calculated from the corresponding angle, δ , as $2f(\tan \delta/2)$, where f is the focal length of the receptor lens.

Table 1 — Angles and dimensions of source image and receptor apertures for Methods A,B,C and D

Method(s)	Instrument characteristics	In plane of measurement		Perpendicular to plane of measurement	
		Angle δ_1 degrees (°)	Dimension ^a mm	Angle δ_2 degrees (°)	Dimension ^a mm
A,B,C and D	Source image size Tolerance	0,75($\delta_{1\alpha}$) $\pm 0,25$	0,65 $\pm 0,22$	2,5($\delta_{2\alpha}$) ^b $\pm 0,5$	2,18 ^b $\pm 0,44$
A	20° Receptor aperture Tolerance	1,80($\delta_{1\beta}$) $\pm 0,05$	1,57 $\pm 0,04$	3,6($\delta_{2\beta}$) $\pm 0,1$	3,14 $\pm 0,09$
B	45° Receptor aperture Tolerance	4,4($\delta_{1\beta}$) $\pm 0,1$	3,84 $\pm 0,09$	11,7($\delta_{2\beta}$) $\pm 0,2$	10,25 $\pm 0,17$
C	60° Receptor aperture Tolerance	4,4($\delta_{1\beta}$) $\pm 0,1$	3,84 $\pm 0,09$	11,7($\delta_{2\beta}$) $\pm 0,2$	10,25 $\pm 0,17$
D	85° Receptor aperture Tolerance	4,0($\delta_{1\beta}$) $\pm 0,3$	3,49 $\pm 0,26$	6,0($\delta_{2\beta}$) $\pm 0,3$	5,24 $\pm 0,26$

^a Calculated for a focal length of 50 mm. For any other focal length, f , these dimensions shall be multiplied by $f/50$.

^b $0,75^\circ \pm 0,25^\circ$, corresponding to dimensions of $0,65 \text{ mm} \pm 0,22 \text{ mm}$, i.e. the same as those in the plane of measurement, is also recommended.

Table 2 — Angles and dimensions of circular source image and circular receptor aperture for 45° reflectometer of Method E

Instrument characteristics	Angle δ degrees (°)	Dimension ^a mm
Source image size Tolerance	3,44 $\pm 0,23$	1,5 $\pm 0,1$
45° Receptor aperture Tolerance	3,44 $\pm 0,23$	1,5 $\pm 0,1$

^a Calculated for focal length of 25,4 mm. For any other focal length, f , the aperture diameter is equal to $2f(\tan \delta/2)$.

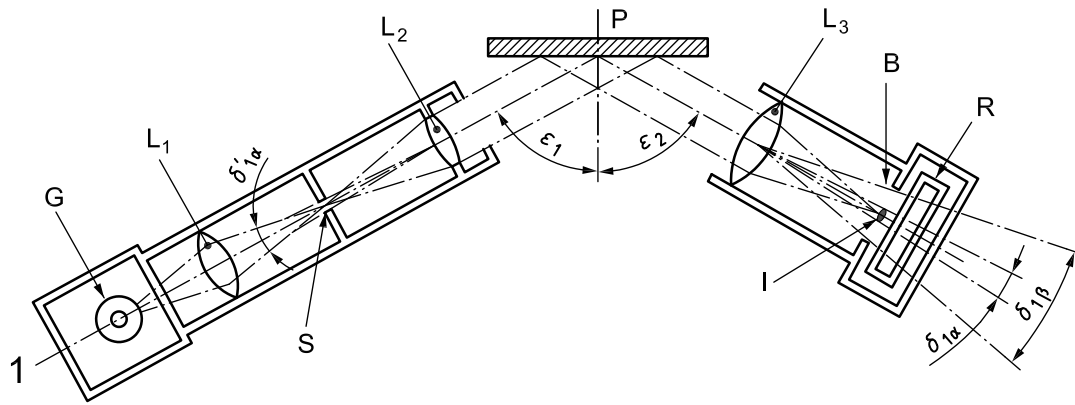

a) In plane of measurement

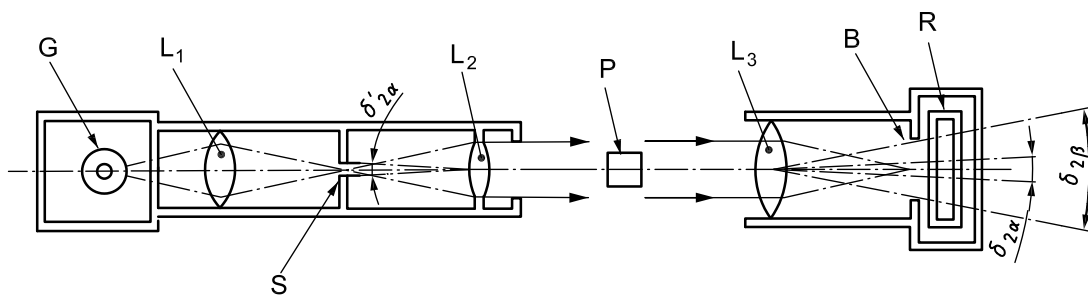

b) Perpendicular to plane of measurement

Key

- | | | | |
|----------------|-----------------------------------|---|--|
| 1 | axis | $\delta_{1\alpha}$ | source image angles (in plane of measurement) |
| G | filament lamp | $\delta_{1\beta}$ | receptor aperture angles (in plane of measurement) |
| L ₁ | condenser lens | $\delta_{2\alpha}$ | source image angles (perpendicular to plane of measurement) |
| L ₂ | collimator lens | $\delta_{2\beta}$ | receptor aperture angles (perpendicular to plane of measurement) |
| L ₃ | receptor lens | $\delta'_{1\alpha} = \delta_{1\alpha}$ and $\delta'_{2\alpha} = \delta_{2\alpha}$ | if the focal lengths of L ₂ and L ₃ are the same |
| S | effective light source (pin note) | ϵ_1 | incident angle |
| P | test surface | ϵ_2 | receptor angle |
| B | receptor field aperture | | |
| I | source image | | |
| R | photoelectric cell | | |

NOTE Angles and dimensions are given in Table 1.

Figure 1 — Schematic arrangement of apparatus showing apertures and source image formation for a collimated-beam-type instrument for Method A (20°), Method B (45°), Method C (60°) and Method D (85°)

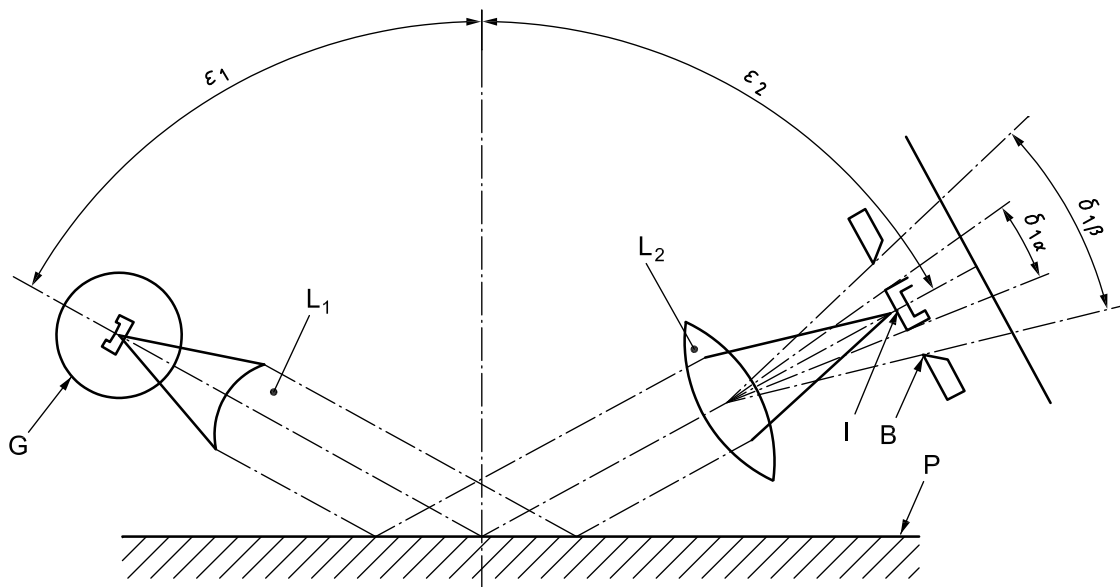

a) In plane of measurement

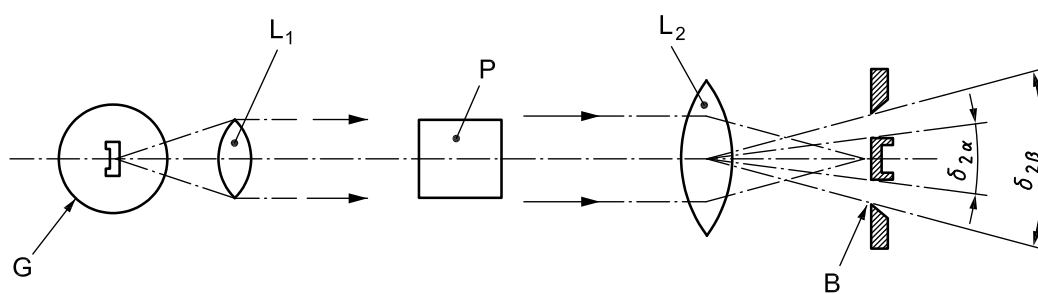

b) Perpendicular to plane of measurement

Key

- G filament lamp
- L_1 and L_2 lenses
- P test surface
- B receptor field aperture
- I image filament
- $\delta_{1\alpha}$ and $\delta_{2\alpha}$ source image angles
- $\delta_{1\beta}$ and $\delta_{2\beta}$ receptor aperture angles
- ϵ_1 incident angle
- ϵ_2 receptor angle

NOTE Angles and dimensions are given in Table 1.

Figure 2 — Schematic arrangement of apparatus showing apertures and source image formation for a non-collimated-beam type instrument for Method A (20°), Method B (45°), Method C (60°) and Method D (85°)

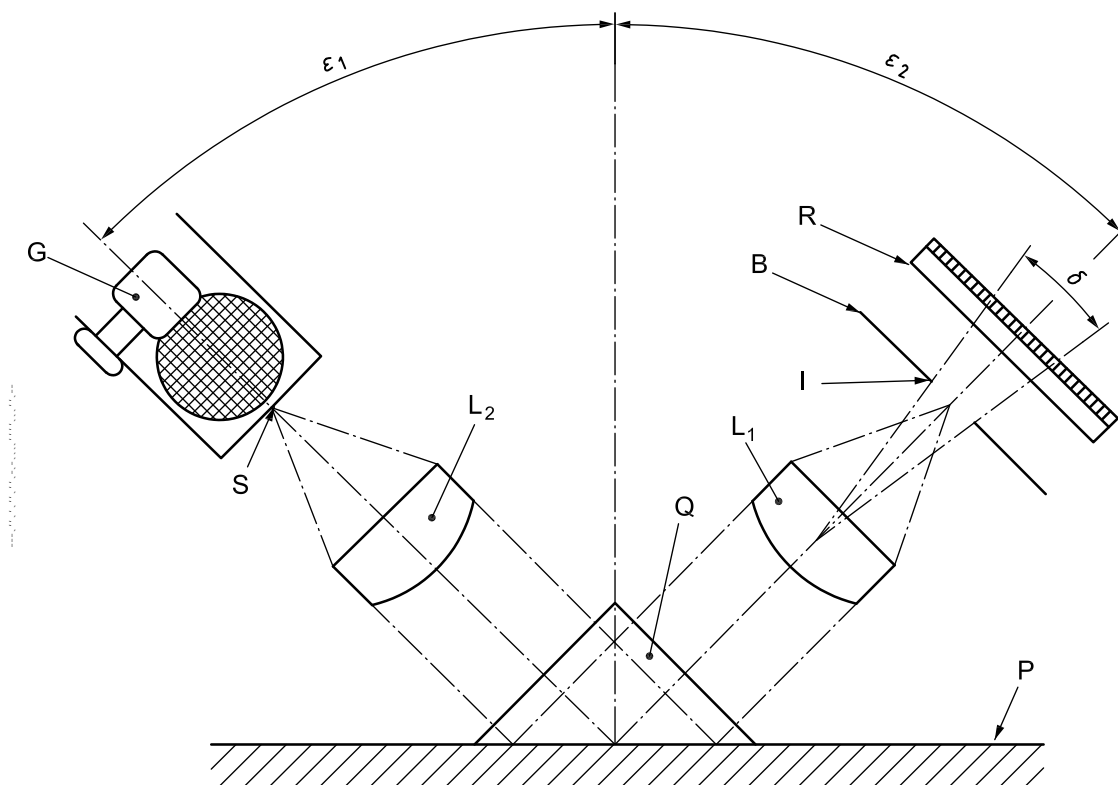

Key

- G lamp with frosted surface
- L_1 and L_2 lenses
- B receptor field aperture
- P test surface
- Q glass prism for calibration
- S source aperture
- I source image
- R photoelectric cell
- δ receptor aperture angle
- ε_1 incident angle
- ε_2 receptor angle
- $\varepsilon_1 = \varepsilon_2 = 45 \pm 0,1^\circ$

NOTE Angles and dimensions are given in Table 2.

Figure 3 — Schematic arrangement of optical system of 45° specular reflectance meter for Method E

5 Optical standards

5.1 Reference standards

5.1.1 Black glass

The primary reference standard shall be made of highly polished black glass of refractive index 1,567 (or clear glass with the back and edges roughened and coated with black paint), the top surface being plane to within two fringes per centimetre as measured by optical interference methods. The effect of the refractive index on specular reflectance and specular gloss values is described in Annex A.

The glass surface shall be kept in a clean condition and free from surface scratches or damage.

5.1.2 Glass prism (for Method E only)

An alternative reference standard, recommended for Method E and suitable only for 45° reflectometers, is provided by the hypotenuse face of a right-angled glass prism, having dimensions of 25 mm × 25 mm × 35,3 mm and optically worked faces. This uses the principle of total internal reflection for angles greater than the critical angle, but there are losses on entering the prism faces. These can also be calculated from Fresnel's equation (see A.1) to give the absolute specular reflectance values given in Table 3.

Table 3 — Specular reflectance values for glass prisms

Refractive index	Specular reflectance for 45° angle
	%
1,500	92,16
1,523	91,59
1,567	90,48
1,600	89,63

The glass shall be in a perfectly clean condition, maintained free from grease and scratches, and with the hypotenuse face accurately located in the correct plane.

5.2 Working standards

5.2.1 Description

Working standards shall comprise front-silver-mirrored or anodized aluminium surfaces of uniform appearance and good planarity which have been calibrated against a primary reference standard (see 5.1) for an indicated area and direction of illumination, which shall be clearly marked on the working standard. Working standards shall be checked periodically by comparison with primary reference standards. The working standards shall be uniform and stable. At least two working standards, of different specular reflectance or specular gloss levels, shall be available for each geometry.

5.2.2 Zero point check

A black box or black velvet shall be used for checking the zero point of the display.

6 Preparation and calibration of apparatus

Calibrate the apparatus at the start of every period of operation and during operation at intervals sufficiently frequent to ensure that the instrument response is essentially constant.

Using a primary reference standard, or the higher of two working standards, adjust the instrument reading to the correct or selected value in the upper part of the scale with the sensitivity control (4.5). If a black-glass standard is used, the instrument shall indicate the relevant specular reflectance value, as indicated in Table 4, for the specular reflectance measurement, or the relevant specular gloss value, as indicated in Table 5, for the specular gloss measurement. If a glass prism is used for Method E, set the reading to the correct value as indicated in Table 3.

Take a second working standard of known specular reflectance or specular gloss for the angle being used, having a value in the lower half of the scale, and make a measurement with the same control settings.

For the specular reflectance measurement, if the reading for the second working standard is within 1 % of its assigned reflectance value, the proportionality requirement of 4.6 is conformed to. For the specular gloss measurement, if the reading for the second working standard in Methods A, B and C is within 1 gloss unit of its assigned value, the proportionality requirement of 4.6 is conformed to. For Method D, the reading for the second working standard with a 60° gloss lower than 10 gloss units shall be within 1 gloss unit of its assigned value. For the second working standard with a 60° gloss higher than 10 gloss units, the reading may be within 2 gloss units of its assigned value.

If these requirements are not conformed to, the instrument shall be adjusted by the manufacturer, or in accordance with the manufacturer's instructions, and the calibration procedure repeated until the second working standard can be measured with the required accuracy.

NOTE The most common cause of incorrect results is damage or distortion of standards through lack of flatness, presence of dirt, or failure to locate the surface in the correct plane for measurement.

7 Measurement of specular reflectance and specular gloss

7.1 General

Calibrate the instrument as directed in Clause 6 and measure the specular reflectance or specular gloss of the test sample by placing it in firm contact with the instrument so that the plane of incidence and reflection is parallel to the direction of rolling or machining of the test sample. Measurement can be carried out in a plane normal to this direction if the anisotropy of the surface under examination is to be assessed.

7.2 Measurement of specular reflectance

For surfaces of low specular reflectance, set the black-glass primary reference standard (see 5.1.1) to read 10 times the relevant specular reflectance value in Table 4 and multiply each reading by 0,1.

For surfaces with a high specular reflectance, set the apparatus to the relevant specular reflectance value specified in Table 4, using a black-glass primary reference standard. Alternatively, in the case of Method E, the reflectometer may be set to the appropriate specular reflectance value specified in Table 3, using a glass prism (see 5.1.2).

NOTE Specular reflectance values which are encountered in practice can cover a very wide range, from 90 % to less than 0,1 %, and only in the case of bright finishes, or with the 85° method, is it practicable to obtain a direct reading of specular reflectance.

7.3 Measurement of specular gloss

Using a black-glass primary reference standard, set the apparatus to the relevant specular gloss value specified in Table 5.

For surfaces with a high specular gloss, in excess of 100 gloss units, set the black-glass primary reference standard at an arbitrary selected value of 0,5 or 0,2 or 0,1 of the specular gloss value in Table 5 and multiply each reading by the corresponding factor (2 or 5 or 10, respectively).

Table 4 — Specular reflectance values for polished black glass

Refractive index <i>n</i>	Angle of incidence			
	20°	45°	60°	85°
1,400	2,800	3,658	7,200	59,832
1,410	2,917	3,791	7,376	60,012
1,420	3,035	3,925	7,552	60,183
1,430	3,155	4,060	7,728	60,345
1,440	3,276	4,196	7,901	60,499
1,450	3,398	4,332	8,074	60,646
1,460	3,522	4,469	8,245	60,786
1,470	3,646	4,607	8,416	60,919
1,480	3,772	4,746	8,584	61,045
1,490	3,899	4,884	8,752	61,166
1,500	4,027	5,024	8,919	61,280
1,510	4,156	5,164	9,084	61,389
1,520	4,285	5,305	9,248	61,492
1,530	4,416	5,446	9,411	61,591
1,540	4,548	5,587	9,573	61,684
1,550	4,681	5,729	9,734	61,773
1,560	4,814	5,871	9,894	61,858
1,567 ^a	4,908 ^a	5,971 ^a	10,006 ^a	61,914 ^a
1,570	4,948	6,014	10,053	61,938
1,580	5,083	6,157	10,211	62,015
1,581	5,102	6,177	10,233	62,025
1,590	5,219	6,299	10,368	62,087
1,600	5,355	6,443	10,524	62,156
1,610	5,493	6,587	10,679	62,221
1,617	5,592	6,691	10,800	62,266
1,620	5,630	6,731	10,833	62,283
1,630	5,769	6,876	10,986	62,342
1,640	5,908	7,020	11,138	62,397
1,648	6,015	7,132	11,255	62,438
1,650	6,048	7,165	11,289	62,449
1,660	6,188	7,310	11,440	62,499
1,670	6,329	7,455	11,590	62,545
1,680	6,470	7,601	11,738	62,589
1,690	6,611	7,746	11,886	62,631
1,700	6,754	7,892	12,034	62,697
1,710	6,896	8,038	12,180	62,706
1,720	7,039	8,183	12,325	62,740
1,730	7,183	8,329	12,470	62,772
1,740	7,327	8,475	12,614	62,802
1,750	7,471	8,621	12,758	62,830
1,760	7,615	8,767	12,901	62,856
1,770	7,760	8,914	13,043	62,879
1,780	7,905	9,060	13,184	62,901
1,790	8,051	9,206	13,324	62,921
1,800	8,197	9,352	13,346	62,940

^a Standard reference sample.

Table 5 — Specular gloss values for polished black glass

Refractive index <i>n</i>	Angle of incidence			
	20°	45°	60°	85°
1,400	57,0	61,3	71,9	96,6
1,410	59,4	63,5	73,7	96,9
1,420	61,8	65,7	75,5	97,2
1,430	64,3	68,0	77,2	97,5
1,440	66,7	70,3	79,0	97,6
1,450	69,2	72,6	80,7	98,0
1,460	71,8	74,9	82,4	98,2
1,470	74,3	77,2	84,1	98,4
1,480	76,9	79,5	85,8	98,6
1,490	79,4	81,8	87,5	98,8
1,500	82,0	84,1	89,1	99,0
1,510	84,7	86,5	90,8	99,2
1,520	87,3	88,8	92,4	99,3
1,530	90,0	91,2	94,1	99,5
1,540	92,7	93,6	95,7	99,6
1,550	95,4	95,9	97,3	99,8
1,560	98,1	98,3	98,9	99,9
1,567 ^a	100,0 ^a	100,0 ^a	100,0 ^a	100,0 ^a
1,570	100,8	100,7	100,5	100,0
1,580	103,6	103,1	102,1	100,2
1,590	106,3	105,5	103,6	100,3
1,600	109,1	107,9	105,2	100,4
1,610	111,9	110,3	106,7	100,5
1,620	114,3	112,7	108,4	100,6
1,630	117,5	115,2	109,8	100,7
1,640	120,4	117,6	111,3	100,8
1,650	123,2	120,0	112,8	100,9
1,660	126,1	122,4	114,3	100,9
1,670	129,0	124,9	115,8	101,0
1,680	131,8	127,3	117,3	101,1
1,690	134,7	129,7	118,8	101,2
1,700	137,6	132,2	120,3	101,2
1,710	140,5	134,6	121,7	101,3
1,720	143,4	137,1	123,2	101,3
1,730	146,4	139,5	124,6	101,4
1,740	149,3	141,9	126,1	101,4
1,750	152,2	144,4	127,5	101,5
1,760	155,2	146,8	128,9	101,5
1,770	158,1	149,3	130,4	101,6
1,780	161,1	151,7	131,8	101,6
1,790	164,0	154,2	133,2	101,6
1,800	167,0	156,6	134,6	101,7

^a Standard reference sample.

8 Expression of results

8.1 General

Express the results as the mean specular reflectance (see 8.2) or the mean specular gloss (see 8.3), and, where appropriate, record the number, the mean, and the extremes of replicate measurements. Indicate whether more than one direction of measurement was used.

8.2 Specular reflectance

If the instrument is set to the relevant specular reflectance of the black glass, then the direct reading is the specular reflectance of the sample under test. If it is set to 10 times this value, then the reading shall be multiplied by 0,1.

8.3 Specular gloss

If the instrument is set to the relevant specular gloss value of a polished black glass, then the reading is the specular gloss of the sample under test. If it is set to 0,5 or 0,2 or 0,1 of the relevant specular gloss, then the reading shall be multiplied by 2 or 5 or 10, respectively.

9 Test report

The test report shall include at least the following information:

- a) a reference to this International Standard, i.e. ISO 7668:2010;
- b) the type and identification of the product tested;
- c) the methods used and whether specular reflectance or specular gloss was measured;
- d) the reference standard used;
- e) the results of the test (see Clause 8);
- f) the date of the test;
- g) any deviation, by agreement or otherwise, from the procedure specified.

Annex A (normative)

Specular reflectance and specular gloss of black glass

A.1 Specular reflectance

The specular reflectance of the black glass, r_s , expressed as a percentage, is given by Equation (A.1) (Fresnel's equation):

$$r_s = \frac{1}{2} \left[\frac{\sin^2(i-r)}{\sin^2(i+r)} + \frac{\tan^2(i-r)}{\tan^2(i+r)} \right] \times 100 \quad (\text{A.1})$$

where

i is the angle of incidence;

r is the angle of reflection.

NOTE $n \sin r = \sin i$, where n is the refractive index measured using the D line of sodium light.

Table 4 gives the calculated specular reflectance values for glass of various refractive indices for each of the measurement angles employed.

The preferred glass has a refractive index of 1,567, but glass with a refractive index of 1,523 has also been used frequently.

A.2 Specular gloss

The specular gloss of the black glass, g_s , also depends on its refractive index, n , and glass of refractive index $n = 1,567$ shall be assigned a specular gloss value of 100 units. If glass of this refractive index is not available, another material of known refractive index, n , may be used, the specular gloss being raised or lowered according to Equation (A.2).

$$g_s = 100 - k(1,567 - n) \quad (\text{A.2})$$

where

$k = 270$ for Method A (20°);

$k = 240$ for Method B (45°);

$k = 160$ for Method C (60°);

$k = 14$ for Method D (85°).

EXAMPLE The specular gloss of black glass having $n = 1,523$ becomes 88,1 at 20°; 89,4 at 45°; 93,0 at 60°; and 99,4 at 85°.

Table 5 gives the calculated specular gloss values for glass of various refractive indices for each of the measurement angles employed.

Bibliography

- [1] CIE 38:1977, *Radiometric and Photometric Characteristics of Materials and their Measurement*

ICS 25.220.20

Price based on 13 pages