**Road vehicles — Trailers up to 3,5 t —
Calculation of the mechanical strength
of steel drawbars**

*Véhicules routiers — Remorques jusqu'à 3,5 t — Calcul de la
résistance mécanique des timons en acier*



Reference number
ISO 7641:2012(E)

© ISO 2012



COPYRIGHT PROTECTED DOCUMENT

© ISO 2012

All rights reserved. Unless otherwise specified, no part of this publication may be reproduced or utilized in any form or by any means, electronic or mechanical, including photocopying and microfilm, without permission in writing from either ISO at the address below or ISO's member body in the country of the requester.

ISO copyright office
Case postale 56 • CH-1211 Geneva 20
Tel. + 41 22 749 01 11
Fax + 41 22 749 09 47
E-mail copyright@iso.org
Web www.iso.org

Published in Switzerland

Contents

	Page
Foreword	iv
1 Scope	1
2 Normative references	1
3 Terms, definitions and symbols	1
3.1 Terms and definitions	1
3.2 Symbols	2
4 Requirements	3
4.1 Maximum of the vertical static force " <i>S</i> "	3
4.2 Material and weldability of the drawbars	3
4.3 Strength calculation	3
Annex A (informative) Examples of configurations	7
Bibliography	14

Foreword

ISO (the International Organization for Standardization) is a worldwide federation of national standards bodies (ISO member bodies). The work of preparing International Standards is normally carried out through ISO technical committees. Each member body interested in a subject for which a technical committee has been established has the right to be represented on that committee. International organizations, governmental and non-governmental, in liaison with ISO, also take part in the work. ISO collaborates closely with the International Electrotechnical Commission (IEC) on all matters of electrotechnical standardization.

International Standards are drafted in accordance with the rules given in the ISO/IEC Directives, Part 2.

The main task of technical committees is to prepare International Standards. Draft International Standards adopted by the technical committees are circulated to the member bodies for voting. Publication as an International Standard requires approval by at least 75 % of the member bodies casting a vote.

Attention is drawn to the possibility that some of the elements of this document may be the subject of patent rights. ISO shall not be held responsible for identifying any or all such patent rights.

ISO 7641 was prepared by Technical Committee ISO/TC 22, *Road vehicles*, Subcommittee SC 4, *Exterior fittings of car/trailer-caravan combinations*.

This first edition of ISO 7641 cancels and replaces ISO 7641-1:1983, which has been technically revised.

.....

Road vehicles — Trailers up to 3,5 t — Calculation of the mechanical strength of steel drawbars

1 Scope

This International Standard gives a simplified procedure for the calculation of the mechanical strength of steel drawbars, whether there are welds or not, for centre-axle trailers Categories O1 and O2 as specified in the UNECE, *Consolidated Resolution on the Construction of Vehicles (R.E.3)*. Consequently, it only applies to simple constructions that enable a calculation in bending.

2 Normative references

The following documents, in whole or in part, are normatively referenced in this document and are indispensable for its application. For dated references, only the edition cited applies. For undated references, the latest edition of the referenced document (including any amendments) applies.

UNECE, *Consolidated Resolution on the Construction of Vehicles (R.E.3)*

3 Terms, definitions and symbols

3.1 Terms and definitions

For the purposes of this document, the following terms and definitions apply.

3.1.1

mechanical coupling device

mechanical coupling component

part fixed to the frame, to self-carrying parts of the bodywork and to the chassis of the tractor and the trailers, used to couple the vehicles

NOTE 1 This includes parts used to attach the coupling device or the components to the vehicle or to actuate the coupling device.

NOTE 2 Mechanical coupling devices transmit horizontal forces in the driving direction or the lateral direction. Vertical supporting forces are also transmitted.

3.1.2

drawbar

separate technical unit attached to the frame of the trailer with or without inertia control devices and comparable equipment parts at the front of the towed vehicles or at the vehicle chassis, adapted to couple with the tractor with help of drawbar eyes, coupling heads of similar devices

NOTE 1 They are fixed in the vertical direction; they are able to receive vertical forces (rigid drawbars). Rigid drawbars can be fixed completely rigid or by means of a suspension. Drawbars can be composed of more than one component. They can be adjustable in height.

NOTE 2 Examples of configurations are shown in Annex A.

3.1.3

chassis part

part of the frame and the bodywork of the trailer, that participate in connecting the bodywork and its load to the axle

3.1.4

simple drawbar

drawbar (3.1.2) composed of either

- two straight arms with open or closed profile with constant or decreasing cross section, or
- a single profile made of a closed constant or decreasing cross section, in which case it can be composed of more than one component, adjustable in height

NOTE 1 Fundamentally there can be mounted inertia control devices or the coupling head/drawbar-eye to the drawbars.

NOTE 2 In the case of simple drawbars, the mechanical resistance can be calculated with sufficient security, so that a dynamic resistance test of the whole construction can be avoided.

3.1.5

centre-axle trailer

trailer having a *drawbar* (3.1.2) which cannot move in a vertical plane independent of the trailer and having an axle or axles positioned close to the centre of gravity of the trailer, when uniformly loaded

NOTE The vertical force imposed on the coupling of the towing vehicle cannot exceed 10 per cent of the maximum mass of the trailer, or 1 000 kg, whichever is the lesser.

3.2 Symbols

<i>e</i>	distance, in metres, from the horizontal axis of the coupling device (coupling ball centre) to the drawbar neutral fibre at the first fixing point to the trailer frame (see Figure 1)
<i>e_x</i>	distance, in metres, from the horizontal axis of the coupling device (coupling ball centre) to the drawbar neutral fibre at the cross section corresponding to the maximum strain rate (see Figure 1)
<i>l_x</i>	distance, in metres, from the vertical axis of the coupling device to the drawbar section corresponding to the maximum strain rate (see Figure 1)
<i>l</i>	distance, in metres, from the vertical axis of the coupling device to the first fixing point to the trailer frame (see Figure 1)
<i>P</i>	maximum manufacturer's total mass of the trailer, in kg as defined by the trailer manufacturer, in consideration of technical elements such as materials strength, braking ability, etc.
<i>D_{lt}</i>	value, in newtons, determined by calculation, corresponding to the longitudinal forces occurring between towing vehicle and trailer:
	$D_{lt} = \frac{g \cdot 32000 \cdot P}{32000 + P}$
<i>k</i>	coefficient for a drawbar with $l > 2,5$ m to be determined as follows: $k = 1,25 - (0,1 \times l)$ with $k_{\min} = 0,6$
<i>S</i>	vertical static force applied to the coupling device

An example of these symbols of distance can be illustrated as shown in Figure 1.

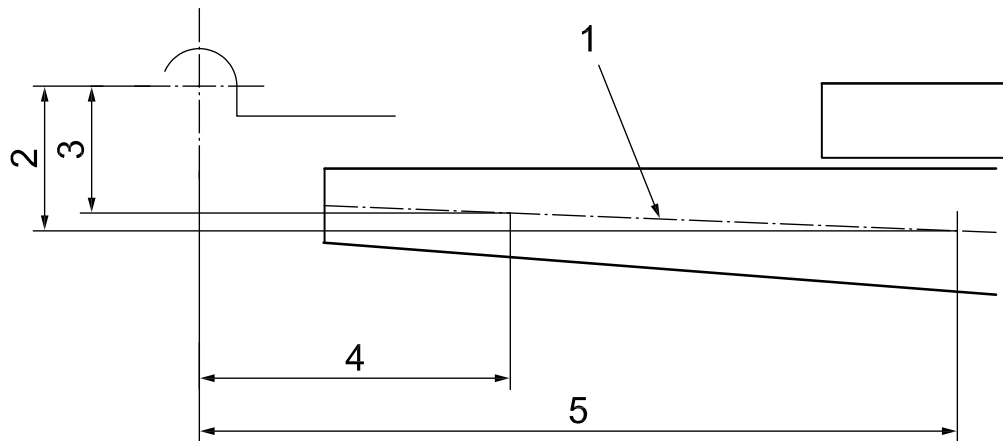

Figure 1 — Drawbar sketch

Key

- 1 Neutral fibre
- 2 e
- 3 e_x
- 4 l_x
- 5 l

4 Requirements**4.1 Maximum of the vertical static force “S”**

The maximum vertical static force “S” on the coupling head shall not exceed the limits set on the Figure 3. If the vertical static force “S” is superior to the limits set on the Figure 3, the validation of the drawbar should be carried out by means of dynamic tests.

4.2 Material and weldability of the drawbars

For welded drawbars, only those grades of steel which contain not more than 0,25 % carbon and the weldability of which is guaranteed by the steel manufacturer shall be used.

The welding process requirements given by the manufacturer shall be followed (preheating, for example).

4.3 Strength calculation**4.3.1 Generalities**

The calculation shall be carried out over the whole length l of the drawbar taking into account distances l_x and e_x in order to determine the maximum strain rate. The strain rate shall be checked at the position where the maximum bending moment occurs when $l = l_x$ and $e = e_x$.

4.3.2 Calculation of the maximum bending moment for drawbars with $e/l < 0,15$ and $e_x/l_x < 0,15$

The calculation of the maximum bending moment for drawbars with $e/l < 0,15$ and $e_x/l_x < 0,15$, expressed in Newton metres, shall be as shown below. Only bending is considered for the calculation.

a) Drawbars with $l \leq 2,5$ m

- 1) for braked trailers: $M_f = 0,36 P g l_x$

2) for non-braked trailers: $M_f = 0,24 P g l_x$

b) Drawbars with $l > 2,5$ m

1) for braked trailers: $M_f = 0,36 P g k l_x$

2) for non-braked trailers: $M_f = 0,24 P g k l_x$

4.3.3 Calculation of the maximum bending moment, expressed in Newton metres, for drawbars with $e/l > 0,15$ and $e_x / l_x > 0,15$

The calculation of the maximum bending moment for drawbars with $e/l > 0,15$ and $e_x/l_x > 0,15$, expressed in Newton metres, shall be as shown below. Only bending is considered for the calculation. Three bending moments, M_f , M_{fD} and M_{fR} shall be calculated; the largest value of the three shall be used for the calculation of the maximum admissible stress (M_{fmax}).

a) Drawbars with $l \leq 2,5$ m

1) for braked trailers:

$$M_f = 0,36 P g l_x$$

$$M_{fD} = 0,8 D e_x$$

$$M_{fP} = 0,75 (M_f + M_{fD})$$

2) for non-braked trailers:

$$M_f = 0,24 P g l_x$$

$$M_{fD} = 1,0 D e_x$$

$$M_{fP} = 0,75 (M_f + M_{fD})$$

b) Drawbars with $l > 2,5$ m

1) for braked trailers:

$$M_f = 0,36 P g k l_x$$

$$M_{fD} = 0,8 D e_x$$

$$M_{fP} = 0,75 (M_f + M_{fD})$$

2) for non-braked trailers:

$$M_f = 0,24 P g k l_x$$

$$M_{fD} = 1,0 D e_x$$

$$M_{fP} = 0,75 (M_f + M_{fD})$$

4.3.4 Calculation of the permissible stress

Stress rates σ calculated for the whole length of the drawbar shall not exceed the allowed stress σ_c :

$$\sigma = \frac{M_f}{\frac{I}{V}}$$

where

$\frac{I}{V}$ is the section modulus of drawbar cross-section corresponding to the maximum bending moment.

a) Drawbars manufactured other than by welding:

$$0,6 \sigma_{Bmin} > \sigma_c < 0,8 \sigma_s$$

where

σ_c is the permissible stress, in newtons per square millimetre of the steel grade utilized

σ_B is the ultimate tensile stress, in newtons per square millimetre of the steel grade utilized

σ_s is the yield stress, in newtons per square millimetre of the steel grade utilized

b) Welded drawbars

$$0,45 \sigma_{Bmin} > \sigma_c < 0,65 \sigma_s$$

4.3.5 Mechanical resistance of chassis parts

It is the responsibility of the trailer manufacturer to design and build the chassis parts so that they can withstand the effects of all the forces transmitted by the drawbar when the trailer is in use.

The permissible stress σ_c can be illustrated as shown in Figure 2.

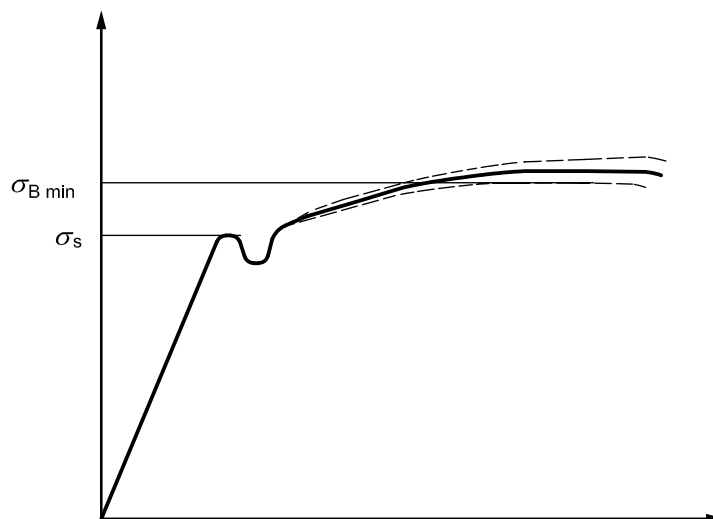
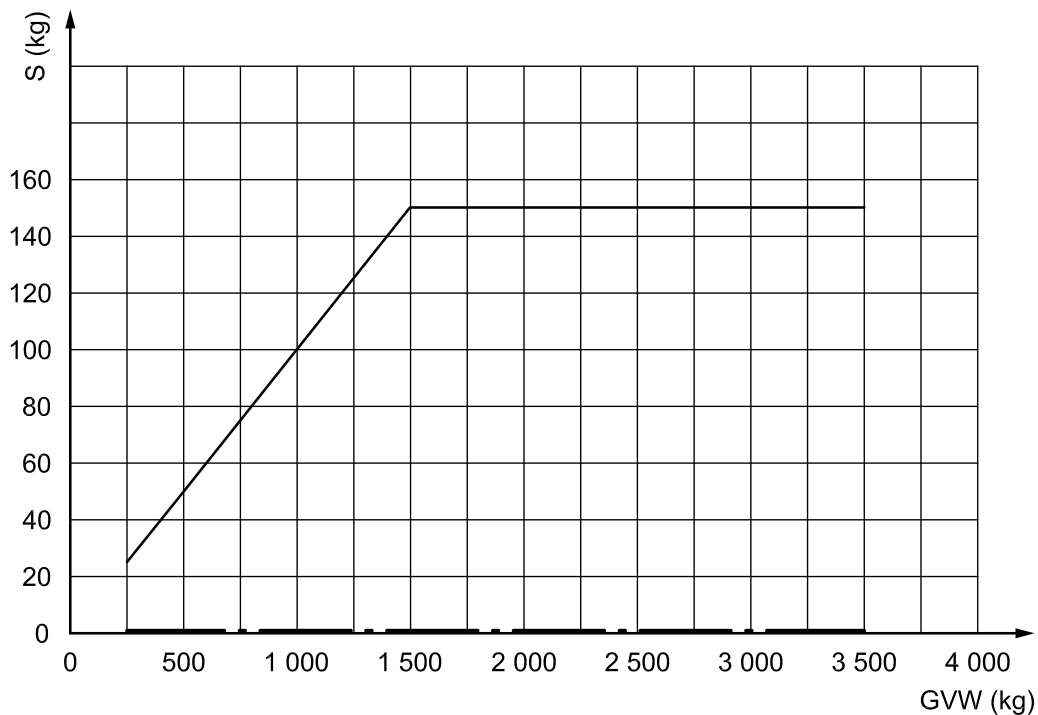

Figure 2 — Permissible stress

The maximum of the vertical static force “S” with the trailer Gross Vehicle Weight (GVW) can be illustrated as shown in Figure 3.



Key

- S static load (kg)
- GVW trailer Gross Vehicle Weight (kg)
- upper limit
- - - lower limit

Figure 3 — Limits of the static force on the coupling as a function of trailer GVW for calculation purpose

Annex A (informative)

Examples of configurations

In all the examples following in this annex, calculation is needed for the front section of the frames where there are no separate drawbars under trailer manufacturer's responsibility.

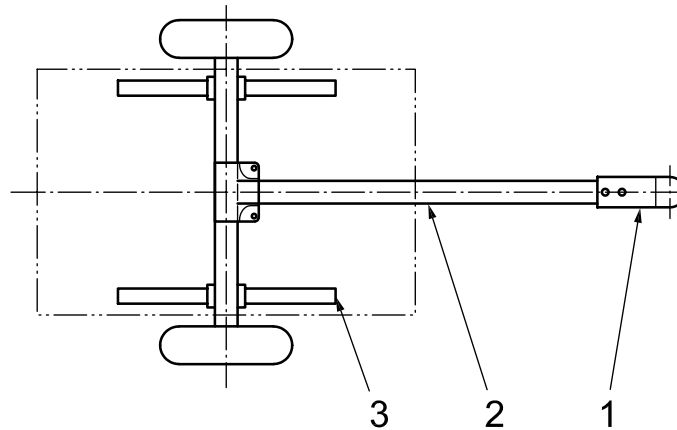

Key

- 1 coupling head
- 2 drawbar
- 3 chassis

NOTE Drawbar is a separate technical unit. Devices for height adjustments can be provided.

Figure A.1 — Drawbar as a separate technical unit

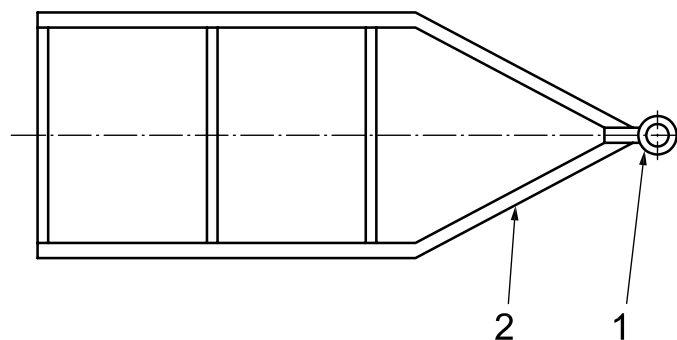

Key

- 1 drawbar eye
- 2 chassis

NOTE Integral chassis-drawbar manufactured by bending, cutting in and welding. Trailer manufacturer's responsibility.

Figure A.2 — Integral chassis-drawbar

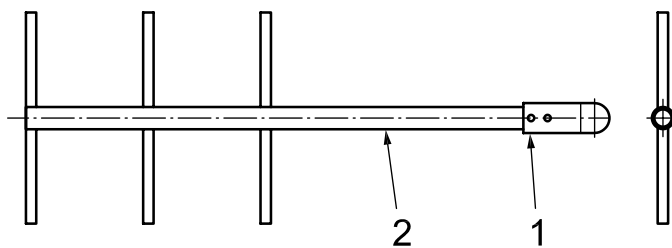

- Key**
- 1 coupling head
 - 2 chassis

NOTE Drawbar is part of the frame; only the coupling head is a separate technical unit. Trailer manufacturer's responsibility.

Figure A.3 — Drawbar as part of the frame

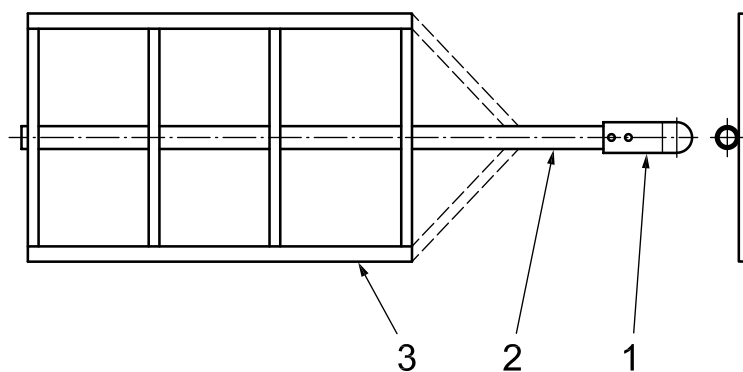

- Key**
- 1 coupling head
 - 2 drawbar
 - 3 chassis

NOTE Drawbar is a separate technical unit from the beginning to the end.

Figure A.4 — Drawbar as a separate technical unit from beginning to end

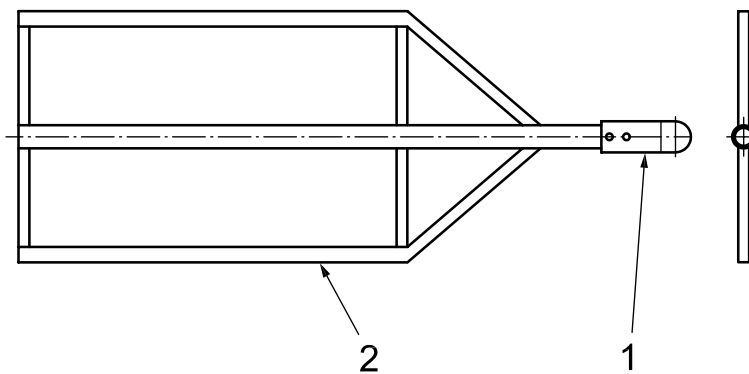

Key

- 1 coupling head
- 2 chassis

NOTE Centre tube is part of the chassis. Trailer manufacturer's responsibility.

Figure A.5 — Centre tube as part of the chassis

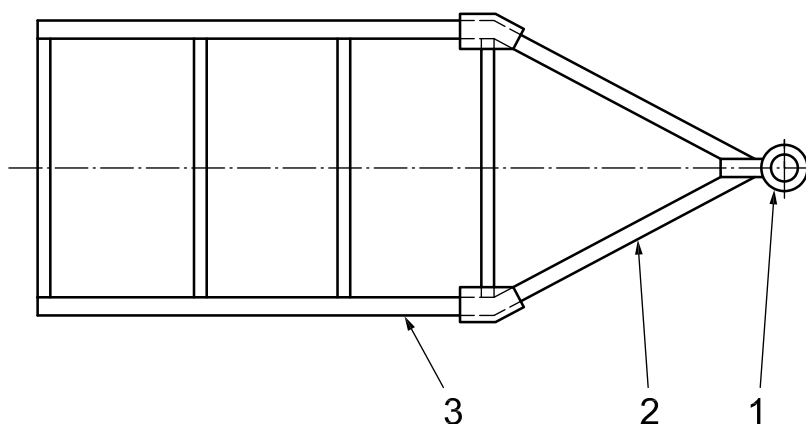

Key

- 1 drawbar eye
- 2 drawbar
- 3 chassis

NOTE V-shaped drawbar, bolted or welded to the ladder-frame (separate technical unit).

Figure A.6 — V-shaped drawbar bolted or welded to the ladder-frame

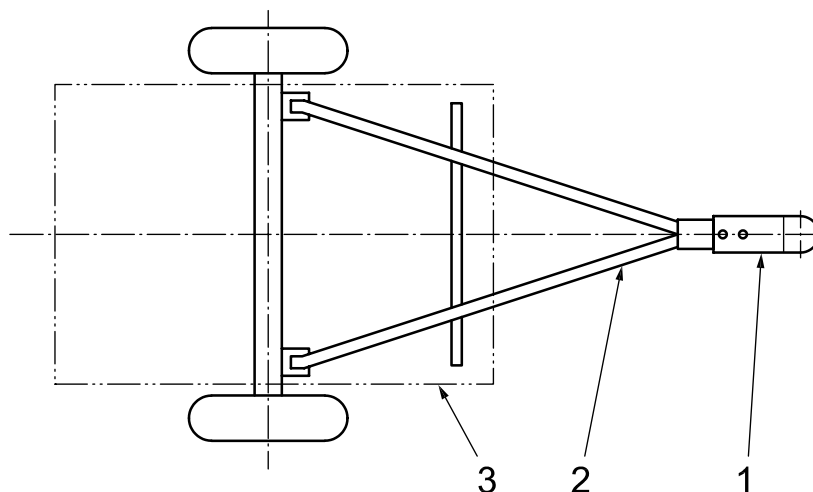

Key

- 1 coupling head
- 2 drawbar
- 3 chassis

NOTE 1 Drawbar with two arms in v-position, approximately in the direction of the pulling force of the trailer. The drawbar is part of the frame; the coupling head and 2 arms in V-position are a separate technical unit. Trailer manufacturer's responsibility.

NOTE 2 In this example, calculation is needed for the front section of the frame under trailer manufacturer's responsibility.

Figure A.7 — Drawbar with two arms in V-position

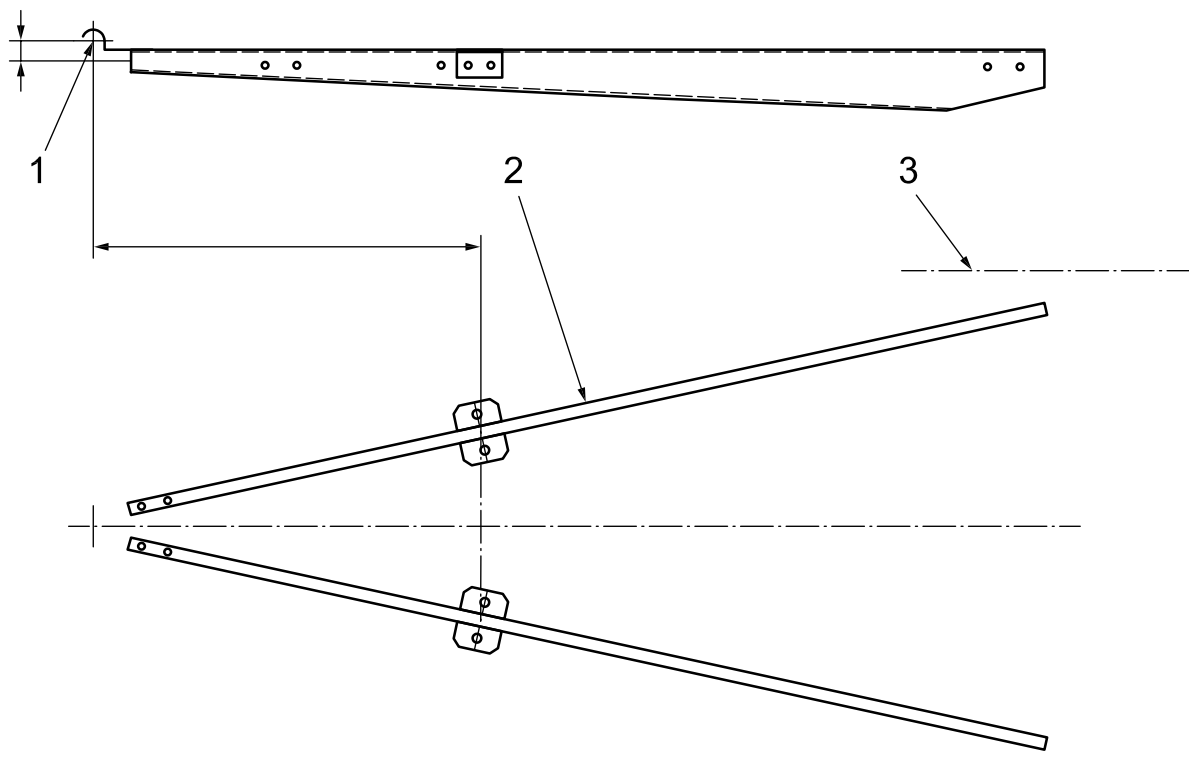

Key

- 1 coupling head
- 2 drawbar
- 3 chassis

NOTE Drawbar with two straight arms (separate technical unit).

Figure A.8 — Drawbar with two straight arms

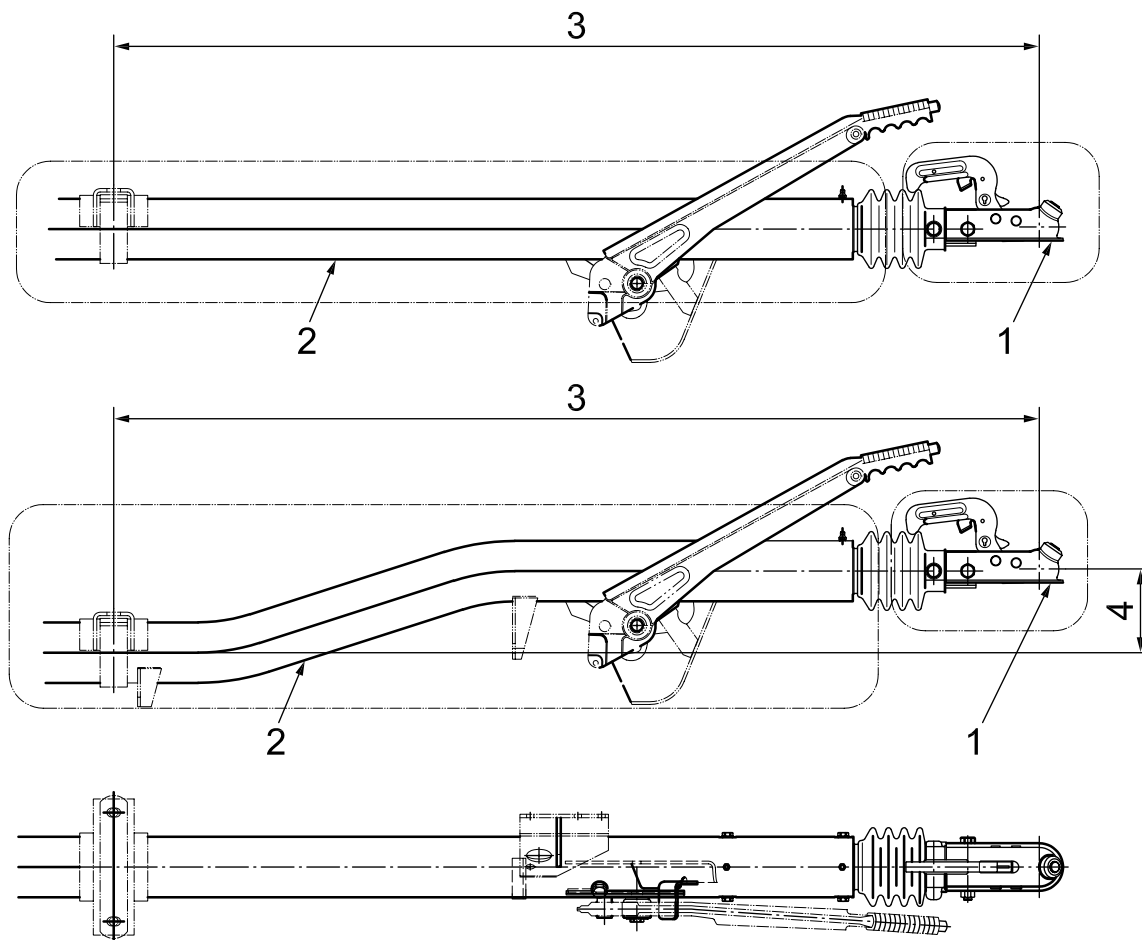

Key

- 1 coupling head
- 2 drawbar
- 3 length l (distance, in metres, from the vertical axis of the coupling device to the first fixing point to the trailer frame)
- 4 height e (distance, in metres, from the horizontal axis of the coupling device to the first fixing point to the trailer frame)

NOTE Tube design drawbar (separate technical unit).

Figure A.9 — Tube design drawbar

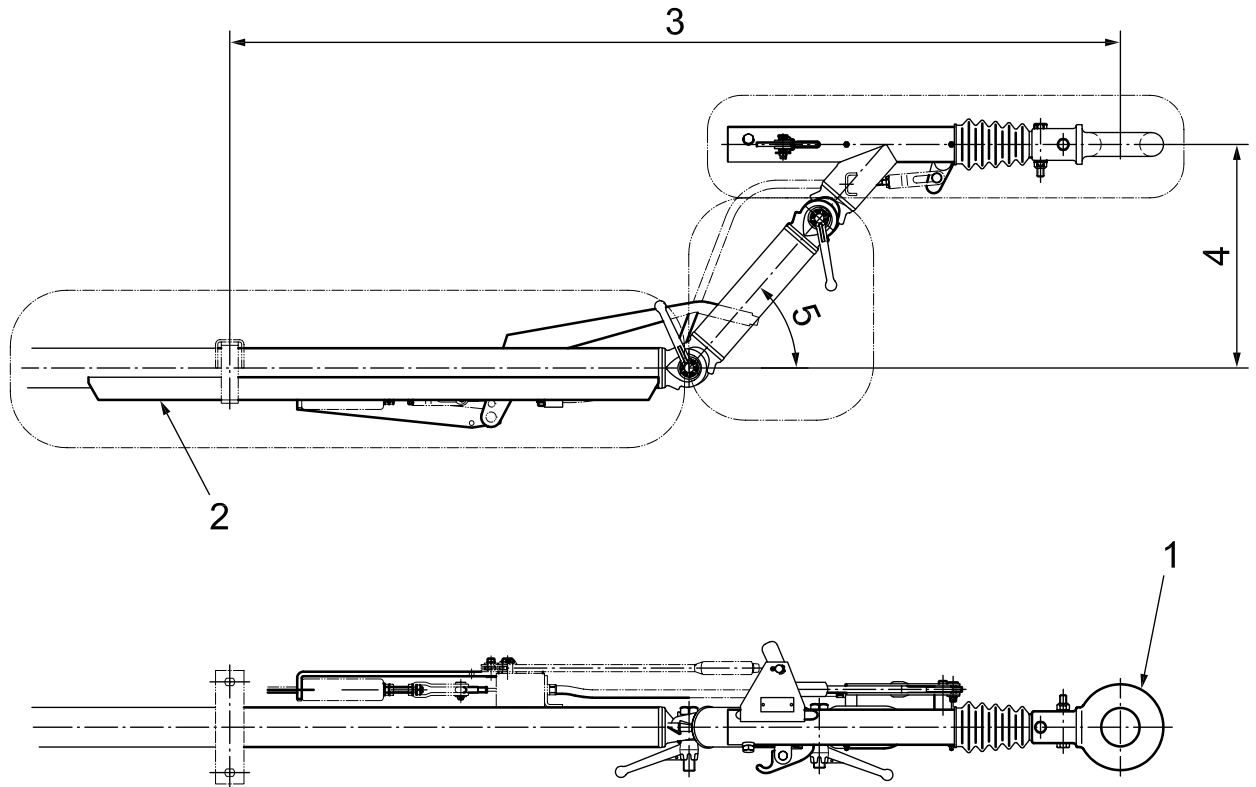

Key

- 1 drawbar eye
- 2 drawbar
- 3 length l (distance, in metres, from the vertical axis of the coupling device to the first fixing point to the trailer frame)
- 4 height e (distance, in metres, from the horizontal axis of the coupling device to the first fixing point to the trailer frame)
- 5 maximum angle

NOTE Multi-components drawbar, adjustable in height (separate technical unit).

Figure A.10 — Multi-components drawbar adjustable in height

Bibliography

- [1] ISO 1176, *Road vehicles — Masses — Vocabulary and codes*

.....

