

---

---

**Road vehicles — Thermoplastics tubing  
for air braking systems**

*Véhicules routiers — Tuyauteries thermoplastiques de dispositifs de  
freinage pneumatique*



Reference number  
ISO 7628:2010(E)

© ISO 2010

**PDF disclaimer**

This PDF file may contain embedded typefaces. In accordance with Adobe's licensing policy, this file may be printed or viewed but shall not be edited unless the typefaces which are embedded are licensed to and installed on the computer performing the editing. In downloading this file, parties accept therein the responsibility of not infringing Adobe's licensing policy. The ISO Central Secretariat accepts no liability in this area.

Adobe is a trademark of Adobe Systems Incorporated.

Details of the software products used to create this PDF file can be found in the General Info relative to the file; the PDF-creation parameters were optimized for printing. Every care has been taken to ensure that the file is suitable for use by ISO member bodies. In the unlikely event that a problem relating to it is found, please inform the Central Secretariat at the address given below.



**COPYRIGHT PROTECTED DOCUMENT**

© ISO 2010

All rights reserved. Unless otherwise specified, no part of this publication may be reproduced or utilized in any form or by any means, electronic or mechanical, including photocopying and microfilm, without permission in writing from either ISO at the address below or ISO's member body in the country of the requester.

ISO copyright office  
Case postale 56 • CH-1211 Geneva 20  
Tel. + 41 22 749 01 11  
Fax + 41 22 749 09 47  
E-mail [copyright@iso.org](mailto:copyright@iso.org)  
Web [www.iso.org](http://www.iso.org)

Published in Switzerland

# Contents

Page

Foreword .....	iv
<b>1 Scope .....</b>	<b>1</b>
<b>2 Normative references .....</b>	<b>1</b>
<b>3 Terms and definitions .....</b>	<b>2</b>
<b>4 Marking and identification .....</b>	<b>2</b>
<b>5 Dimensions .....</b>	<b>3</b>
<b>6 Manufacture .....</b>	<b>4</b>
<b>6.1 Materials .....</b>	<b>4</b>
<b>6.2 Tubing .....</b>	<b>4</b>
<b>7 Installation on the vehicle .....</b>	<b>4</b>
<b>7.1 Use of tube assemblies on the vehicle .....</b>	<b>4</b>
<b>7.2 Installation precautions .....</b>	<b>4</b>
<b>8 Testing and requirements .....</b>	<b>5</b>
<b>9 Test procedures and requirements .....</b>	<b>7</b>
<b>9.1 Burst test .....</b>	<b>7</b>
<b>9.2 Deformation under pressure .....</b>	<b>9</b>
<b>9.3 Cold impact test .....</b>	<b>9</b>
<b>9.4 Impact test after heat ageing .....</b>	<b>10</b>
<b>9.5 Layer adhesion test multilayer pipes .....</b>	<b>10</b>
<b>9.6 Moisture absorption .....</b>	<b>10</b>
<b>9.7 Low temperature flexural test .....</b>	<b>10</b>
<b>9.8 Stress cracking test .....</b>	<b>11</b>
<b>9.9 Resistance to ethanol .....</b>	<b>12</b>
<b>9.10 Resistance to battery acid .....</b>	<b>12</b>
<b>9.11 Resistance to oil .....</b>	<b>13</b>
<b>9.12 Resistance to urea solution .....</b>	<b>13</b>
<b>9.13 Heat ageing .....</b>	<b>14</b>
<b>9.14 Artificial weathering test .....</b>	<b>14</b>
<b>9.15 Ozone test .....</b>	<b>14</b>
<b>9.16 Tube assemblies .....</b>	<b>15</b>
<b>Annex A (normative) Cold impact apparatus .....</b>	<b>16</b>
<b>Annex B (normative) Tests on tube assemblies (tube with end fittings) .....</b>	<b>19</b>
<b>Annex C (informative) Method for leak detection in leak-proof testing .....</b>	<b>22</b>
<b>Annex D (informative) Synopsis of test and corresponding samples .....</b>	<b>25</b>
<b>Bibliography .....</b>	<b>26</b>

## Foreword

ISO (the International Organization for Standardization) is a worldwide federation of national standards bodies (ISO member bodies). The work of preparing International Standards is normally carried out through ISO technical committees. Each member body interested in a subject for which a technical committee has been established has the right to be represented on that committee. International organizations, governmental and non-governmental, in liaison with ISO, also take Part in the work. ISO collaborates closely with the International Electrotechnical Commission (IEC) on all matters of electrotechnical standardization.

International Standards are drafted in accordance with the rules given in the ISO/IEC Directives, Part 2.

The main task of technical committees is to prepare International Standards. Draft International Standards adopted by the technical committees are circulated to the member bodies for voting. Publication as an International Standard requires approval by at least 75 % of the member bodies casting a vote.

Attention is drawn to the possibility that some of the elements of this document may be the subject of patent rights. ISO shall not be held responsible for identifying any or all such patent rights.

ISO 7628 was prepared by Technical Committee ISO/TC 22, *Road vehicles*, Subcommittee SC 2, *Braking systems and equipment*.

This first edition cancels and replaces the second edition of ISO 7628-1:1998, the first edition of ISO 7628-2:1998 and ISO 7628-2/Cor.1:1999, which have been technically revised.

# Road vehicles — Thermoplastics tubing for air braking systems

**WARNING** — The use of this International Standard may involve hazardous materials, operations, and equipment. This International Standard does not purport to address all of the safety concerns, if any, associated with its use. It is the responsibility of the user of this International Standard to establish appropriate safety and health practices and determine the applicability of regulatory limitations prior to use.

## 1 Scope

This International Standard specifies the minimum requirements for mono wall and multilayer tubing used in air braking systems on road vehicles. The conformity of production is the responsibility of the tubing manufacturer.

The marking of the tubing does not automatically imply that the tube assembly (i.e. tube with end fittings) is appropriate for its use on a vehicle.

It is the responsibility of the tube assembler and/or the vehicle manufacturers to ensure that the tests described in Annex B, relating to the tube assembly itself, are successfully performed.

For the requirements on coiled tube assemblies refer to ISO 7375-1 and ISO 7375-2.

## 2 Normative references

The following referenced documents are indispensable for the application of this document. For dated references, only the edition cited applies. For undated references, the latest edition of the referenced document (including any amendments) applies.

ISO 179-1, *Plastics — Determination of Charpy impact properties — Part 1: Non-instrumented impact test*

ISO 1043-1, *Plastics — Symbols and abbreviated terms — Part 1: Basic polymers and their special characteristics*

ISO 1183-1, *Plastics — Methods for determining the density of non-cellular plastics — Part 1: Immersion method, liquid pycnometer method and titration method*

ISO 4892-2:2006, *Plastics — Methods of exposure to laboratory light sources — Part 2: Xenon-arc lamps*

ISO 4892-4:2004, *Plastics — Methods of exposure to laboratory light sources — Part 4: Open-flame carbon-arc lamps*

ASTM B117, *Standard Practice for Operating Salt Spray (Fog) Apparatus*

### 3 Terms and definitions

For the purposes of this document, the following terms and definitions apply.

#### 3.1

##### **tube**

tubing which has been cut to its appropriate length

#### 3.2

##### **tube assembly**

tube which has been equipped with suitable end fittings

#### 3.3

##### **tubing without fittings**

tubing of unspecified length without end fittings

#### 3.4

##### **tubing with fittings**

tubing of a specified length with end fittings

#### 3.5

##### **impact energy**

energy determined by means of an impact bending test

### 4 Marking and identification

Tubings shall be indelibly marked along a generating line with letters of a minimum height of 2 mm and repeated at least every 350 mm as follows:

- ISO 7628;
- tubing category, i.e. either 1 000 kPa or 1 250 kPa for the temperature range  $-40\text{ }^{\circ}\text{C}$  to  $100\text{ }^{\circ}\text{C}$ ;
- tubing category, 1 250 kPa; for the temperature range  $-40\text{ }^{\circ}\text{C}$  to  $125\text{ }^{\circ}\text{C}$ ;
- outside diameter times wall thickness;
- symbol for the material type, in accordance with ISO 1043-1;
- manufacturer designation;
- date code of manufacture.

These seven indications shall be separated from each other by slashes.

## 5 Dimensions

The tubing defined in this International Standard belongs to four possible categories, as defined in Table 1.

**Table 1 — Tubing categories for air braking systems**

Category	Maximum working pressure kPa	Minimum temperature °C	Maximum temperature °C
0	1 000	-40	80
1	1 000	-40	100
2	1 250	-40	100
3 <sup>a</sup>	1 250	-40	125

<sup>a</sup> For use in the engine compartment.

Tubing shall have the dimensions given in Table 2.

**Table 2 — Dimensions**

Nominal tubing size outside diameter mm	Tubing basic outside diameter mm	Outside diameter tolerances	Inside diameter basic mm	Inside diameter tolerances	Minimum wall thickness, <i>e</i> mm
4 × 1	4	±0,1	2	±0,1	0,9
6 × 1	6	±0,1	4	±0,1	0,9
8 × 1	8	±0,1	6	±0,1	0,9
9 × 1,5	9	±0,1	6	±0,1	1,4
10 × 1	10	±0,1	8	±0,1	0,9
10 × 1,25	10	±0,1	7,5	±0,1	1,15
11 × 1,5	11	±0,15	8	±0,15	1,35
12 × 1,5	12	±0,15	9	±0,15	1,35
14 × 2	14	±0,15	10	±0,15	1,85
15 × 1,5	15	±0,15	12	±0,15	1,35
16 × 2	16	±0,15	12	±0,15	1,85
18 × 2	18	±0,15	14	±0,15	1,85
19 × 2	19	±0,15	15	±0,15	1,85

## 6 Manufacture

### 6.1 Materials

The tubing shall be extruded from 100 % virgin material (not reground). The use of recycled material is not permitted, but own reworked material may be used as grinding stock, as long as it does not make up more than 20 % of the new material, is of the same material type and is from the manufacturer's own production, and the tubing meets all other requirements of this International Standard. If reinforcement is used, then the user must be satisfied that the reinforced tubing is suitable for the application. The materials used may have additives to enhance material performance provided the tubing produced complies with the requirements of this International Standard.

### 6.2 Tubing

#### 6.2.1 Quality and appearance

The tubing shall comply with the requirements of this International Standard. The tube shall show no manufacturing faults, voids, scratches, cracks or lack of homogeneity which could affect service use. Additives shall be evenly distributed throughout the material.

#### 6.2.2 Construction

##### 6.2.2.1 General

Tubing shall consist of an extrudate of one or more layers.

##### 6.2.2.2 Inner layer

The materials used in the inner layer should be able to withstand contact with chemicals found in a system environment. The inner layer of the tubing can be exposed to such an environment at the "ends" that are attached to the various connection points in a system.

##### 6.2.2.3 Colour

The outermost layer may be of a different colour to the subsequent layers but must be the colour designated by the end user.

## 7 Installation on the vehicle

### 7.1 Use of tube assemblies on the vehicle

The choice of appropriate fittings and tube shall be approved by the vehicle manufacturer.

In order to allow its mounting on the vehicle, the tube assembly shall have been tested in accordance with Annex B.

### 7.2 Installation precautions

When installed on a vehicle, the tube shall be routed and supported so as to

- eliminate chafing, abrasion, kinking or other mechanical damage,
- minimize fatigue conditions and
- avoid excessive sag.

The tube should be stored inside a dry environment not exceeding a temperature of 40 °C.



## 8 Testing and requirements

For the purpose of these tests, the tube samples shall be at least two weeks (336 h) old. Unless otherwise stated, the tests shall be performed at an ambient temperature of  $(23 \pm 2)$  °C, at a relative humidity between 45 % and 75 %, and unpressurized. All burst tests shall be conducted using the same type of fitting.

The list of appropriate tests to be performed on the tubing is given in Table 3. All the tests listed in Tables 3 and 4 shall be successfully completed before the marking of the tube.

**Table 3 — List of tests**

Test	Subclause	Tube size to test
Surface appearance	6.2.1	Every
Burst at 23 °C	9.1.2	Every
Burst at 100 °C	9.1.3	Every
Burst at 125 °C	9.1.4	Every
Deformation under pressure	9.2	Every
Cold impact	9.3	Every
Impact after ageing	9.4	Every
Layer adhesion	9.5	Sample
Moisture absorption	9.6	Sample
Low temperature flexural	9.7	Sample
Stress cracking	9.8	Sample
Resistance to ethanol	9.9	Sample
Resistance to battery acid	9.10	Sample
Resistance to oil	9.11	Sample
Resistance to urea	9.12	Sample
Heat ageing	9.13	Sample
Artificial weathering	9.14	Sample
Ozone	9.15	Sample
Tube assemblies	9.16	Every

Table 4 — Requirements

Test	Requirement	Subclause
Surface appearance	No manufacturing faults, voids, scratches, cracks or lack of homogeneity which could affect service use. Additives evenly distributed throughout the material.	6.2.1
Burst	All five samples:	9.1.2
at 23 °C	1 000 kPa (10 bar) tubes; > 4 000 kPa (40 bar) 1 250 kPa (12,5 bar) tubes; > 5 000 kPa (50 bar)	
at 80 °C	1 000 kPa (10 bar) tubes; > 2 500 kPa (25 bar)	
at 100 °C	1 000 kPa (10 bar) tubes; > 2 500 kPa (25 bar) 1 250 kPa (12,5 bar) tubes; > 3 130 kPa (31,3 bar)	
at 125 °C	1 250 kPa (12,5 bar) tubes; > 2 500 kPa (25 bar)	
Deformation under pressure	All three samples Deviation between datum lines $\leq 3\%$ Deviation outer diameter $\leq 10\%$ initial mean diameter	9.2
Cold impact	All five samples No cracks or breaks One sample: cracks or breaks, further ten samples to be tested and pass.	9.3
Impact after ageing	All ten samples no cracks or breaks	9.4
Layer adhesion	All five samples no cracks or breaks	9.5
Moisture absorption	As agreed between customer and supplier	9.6
Low temperature flexural	All three samples No damage Rewound area; pass burst test at 23 °C	9.7
Stress cracking	All six samples No cracks or breaks Burst pressure at 23 °C > 80 % of the reference value measured on samples from the same batch	9.8
Resistance to ethanol	All three samples no evidence of cracking	9.9
Resistance to battery acid	All three samples No dimensional change exceeding $\pm 2\%$ Change in weight $\leq 2\%$ No evidence of cracking Tensile force > 80 % of the minimum applied tensile force in accordance with Annex B	9.10
Resistance to oil	Average volume change of three samples < 5 %	9.11
Resistance to urea	All three samples no evidence of cracking	9.12
Heat ageing	To be specified by the end user	9.13
Artificial weathering	All three samples Burst test at 23 °C Burst pressure at 23 °C > 80 % initially measured on samples from the same batch All three samples ductile burst area	9.14
Ozone	The samples shall show no evidence of cracks when visually inspected under seven-power magnification	9.15
Tube assemblies	Pull out strength; no loosening or pull off shall occur. Neither the tube nor the fittings shall fail Leak test; no leakage Vibration test; end user's specification Pulsating pressure fatigue test No sign of failure or leakage Burst test requirements mentioned above and at least 80 % of the reference value measured on samples from the same batch Salt spray test; no evidence of cracking	9.16

## 9 Test procedures and requirements

### 9.1 Burst test

#### 9.1.1 Test procedure

The burst test shall be carried out on five tube assemblies for each temperature. The tube length between the end fittings shall be approximately 150 mm. The test procedure comprises the steps given in 9.1.2, 9.1.3 and 9.1.4.

#### 9.1.2 Burst at 23 °C

Soak the tube assemblies in water at 23 °C for 10 min to 15 min. Before testing, keep the tube assemblies for the following times at 23 °C and (50 ± 10) % relative humidity:

- a) 1 h minimum for tubes with a nominal wall thickness  $e \leq 1,25$  mm (see Table 2);
- b) 2 h minimum for tubes with a nominal wall thickness  $e > 1,25$  mm (see Table 2).

Apply hydrostatic pressure at a constant rate by means of a hydraulic pump or accumulator system with a calibrated pressure gauge at such a speed that the tube will burst between 30 s and 60 s after starting to pressurize the tube.

The burst pressure at 23 °C is the maximum pressure obtained during the test.

NOTE Fittings can be specified in agreement with the customer.

#### 9.1.3 Burst at 80 °C and 100 °C

This test shall be performed with an inert internal pressurizing medium and air outside.

Place the assemblies in an oven at (80 ± 2) °C or (100 ± 2) °C respectively and allow to condition for 1 h. Apply pressure at a constant rate by means of a pump or accumulator system with a calibrated pressure gauge at such a speed that the tube will burst between 30 s and 60 s after starting to pressurize the tube.

The burst pressure at 80 °C or 100 °C is the maximum pressure obtained during the test.

NOTE Fittings can be specified in agreement with the customer.

#### 9.1.4 Burst at 125 °C

This test shall be performed with an inert internal pressurizing medium and heated air, water or silicon oil outside the tube.

Place the assemblies in an appropriate autoclave. The autoclave shall be equipped with a suitable coupling unit for fitting the tubes and connecting to the pressurizing equipment (Figure 1). Heat the medium, preferably water, in the autoclave to the required temperature and keep the temperature constant for 10 min. Apply pressure at a constant rate by means of a pump or accumulator system with a calibrated pressure gauge at such a speed that the tube will burst between 30 s and 60 s after starting to pressurize the tube.

The burst pressure at 125 °C is the maximum pressure obtained during the test.

NOTE 1 The autoclave should preferably be suitable for the different tube sizes specified in Table 2.

NOTE 2 Fittings can be specified in agreement with the customer.

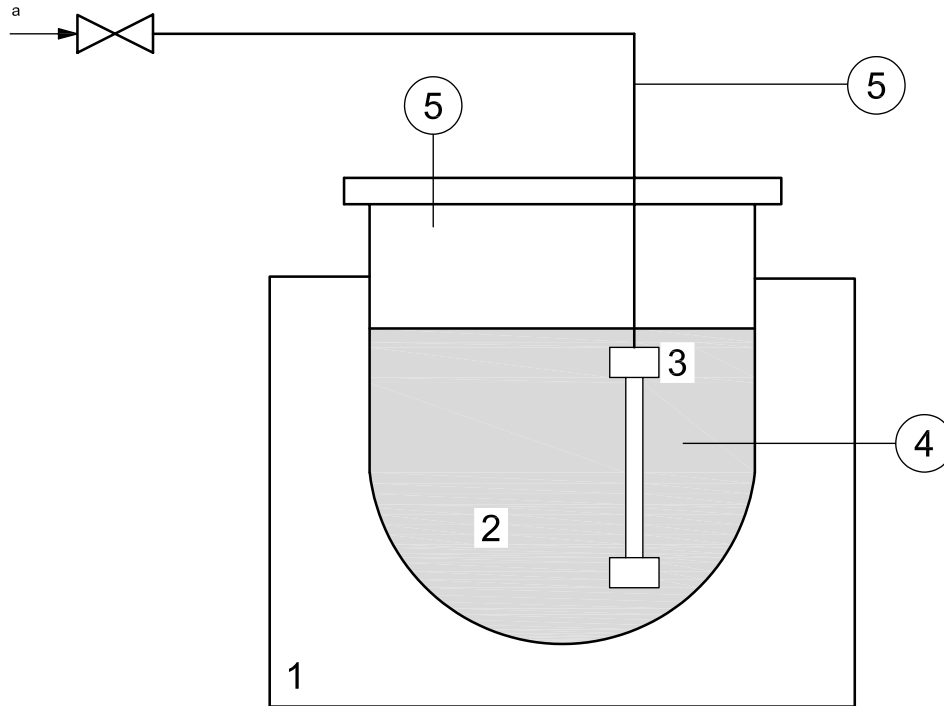

**Key**

- 1 heating mantel
- 2 autoclave
- 3 pipe assembly
- 4 thermometer heating medium
- 5 pressure gauge
- a Gas inlet.

**Figure 1 — Burst test at 125 °C — Schematic figure**

**9.1.5 Requirements**

The burst criterion is the burst of the tube itself.

All five samples shall have a burst pressure as specified in Table 5.

**Table 5 — Burst pressure**

Test temperature	Tube class	Burst pressure
23 °C	1 000 kPa (10 bar)	> 4 000 kPa (40 bar)
	1 250 kPa (12,5 bar)	> 5 000 kPa (50 bar)
80 °C	1 000 kPa (10 bar)	> 2 500 kPa (25 bar)
100 °C	1 000 kPa (10 bar)	> 2 500 kPa (25 bar)
	1 250 kPa (12,5 bar)	> 3 150 kPa (31,5 bar)
125 °C	1 250 kPa (10 bar)	> 2 500 kPa (25 bar)

## 9.2 Deformation under pressure

### 9.2.1 Test procedure

This test shall be carried out on three tube assemblies. The tube length shall be approximately 300 mm between the end fittings.

Condition the tube assemblies for 24 h at 23 °C.

Mark the tube with two datum lines at approximately 50 mm from the end fittings. Measure the initial length between these datum lines and the initial outer diameter of the tube. Fix one end of each sample.

At  $t = 0$  min expose the samples for 1 h at  $(80 \pm 2)$  °C for category 0,  $(100 \pm 2)$  °C for categories 1 and 2 and  $(125 \pm 2)$  °C for category 3. At  $t = 55$  min the pressure shall be gradually increased to reach a pressure of 125 % of the maximum working pressure after 30 s to 60 s (see Figure 2) and hold until  $t = 60$  min.

Stabilize the tube at 23 °C for one hour and measure the length between the datum lines and the outer diameter of the tube.

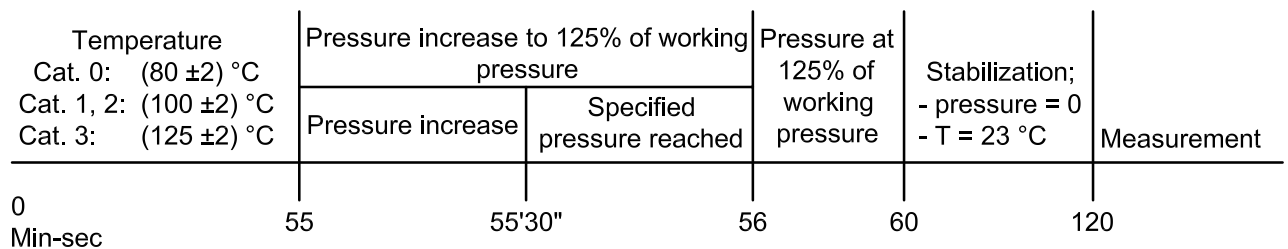

Figure 2 — Deformation under pressure; time line

### 9.2.2 Requirement

The length between the datum lines shall not deviate by more than 3 % from the initial measured length and the outer diameter shall not deviate by more than 10 % from the mean value of the initial measured diameter.

## 9.3 Cold impact test

### 9.3.1 Test procedure

This test shall be carried out on five tube samples 150 mm minimum in length with a test apparatus in accordance with Annex A.

Condition the tube samples for 2 h at  $(-40 \pm 2)$  °C. Within 5 s of removal from the cold cabinet, subject the samples to a cold impact test at 23 °C.

### 9.3.2 Requirements

The five tube samples shall exhibit neither cracks nor breaks. Samples that are only deformed are considered to have passed the test.

If only one sample exhibits cracks or breaks, a further ten samples shall be tested. If more than one of these ten samples exhibits failure, then the tube is considered to have failed the test.

## 9.4 Impact test after heat ageing

### 9.4.1 Procedure

The impact test shall be carried out on three tube samples about 150 mm in length, with a test apparatus in accordance with Annex A.

Expose the samples in a circulating air oven to a temperature of  $(150 \pm 2)$  °C for 72 h, then cool them down to 23 °C over a period of 4 h. Subject each sample to an impact test at 23 °C.

### 9.4.2 Requirement

The samples shall show no evidence of cracks or breaks.

## 9.5 Layer adhesion test multilayer pipes

### 9.5.1 Procedure

This test shall be carried out on five tube samples 150 mm minimum in length and consists of the cold impact test (see 9.3) followed by a burst test at 23 °C (see 9.1.2).

### 9.5.2 Requirement

The samples shall show no delamination at the fractured surface.

NOTE 1 Fittings can be specified in agreement with the customer.

NOTE 2 The layer adhesion test can be combined with the cold impact test (see 9.3).

## 9.6 Moisture absorption

### 9.6.1 Procedure

This test shall be carried out on three tube samples approximately 40 mm in length.

Expose the samples for 24 h in a circulating air oven to a temperature of  $(100 \pm 2)$  °C. Remove the samples from the oven, weigh immediately and expose the samples for 100 h at 100 % relative humidity at 23 °C. After 5 min, remove surface moisture from both the interior and exterior surfaces of the tube and reweigh. The moisture absorption is determined by the mass variation.

### 9.6.2 Requirement

The requirement shall be agreed between customer and supplier.

## 9.7 Low temperature flexural test

### 9.7.1 Procedure

The test shall be carried out on three straight tube or tube assembly samples 300 mm minimum in length.

Condition the samples in a cold chamber for 2 h at  $(-40 \pm 2)$  °C. Include the mandrel with a diameter  $10 \times$  the outer diameter of the tubing. After conditioning and within 60 s, bend the samples  $\geq 180^\circ$  around the mandrel. After a 4 h stabilization period at an ambient temperature of 23 °C, subject each sample to the burst test at 23 °C described in 9.1.2. The length necessary for the burst test shall include the rewound area.

### 9.7.2 Requirements

The samples shall show no evidence of damage (e.g. cracks, crazing, kinking).

All three samples shall pass the burst test at 23 °C (see 9.1.2).

## 9.8 Stress cracking test

### 9.8.1 Test principle

The tube assembly samples shall be exposed for a certain period of time to a high level of humidity at 60 °C, with intermittent short immersions in a corrosive solution at ambient temperature. The tube assemblies shall be bent in accordance with Figure 3.

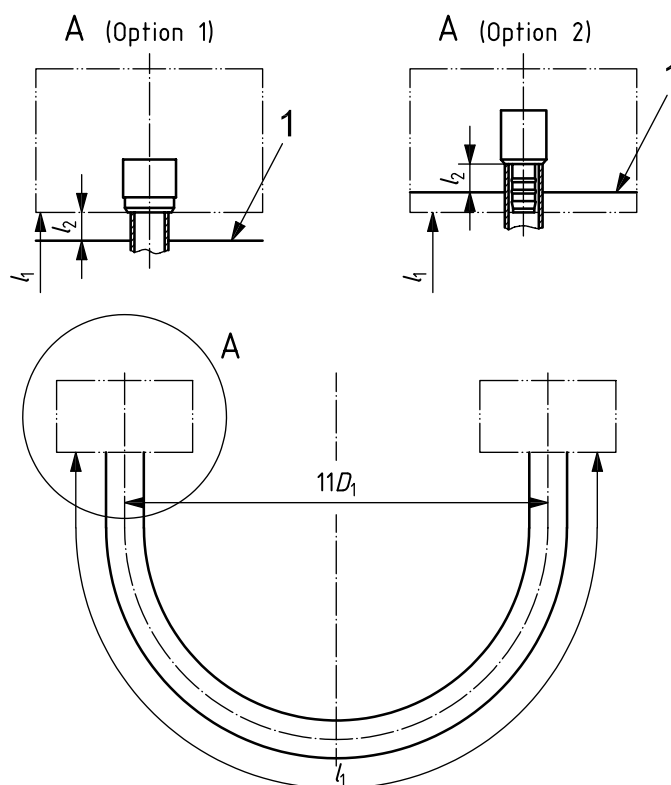

$$l_1 = (11\pi D_1/2) + 4 D_1$$

$$l_2 = 5 \pm \frac{5}{0} \text{ mm}$$

where:

$l_1$  is the length of the free tube/fitting contact area;

$l_2$  is the distance between the tube and the solution surface;

$D_1$  is the outer diameter of the tube.

#### Key

1 level of the solution

Figure 3 — Stress cracking test

### 9.8.2 Specification of the corrosive solution

- 50 % water;
- 50 % mixture of:
  - 30 % copper chloride,
  - 20 % sodium chloride,
  - 20 % potassium chloride,
  - 30 % zinc chloride.

### 9.8.3 Test procedure

The test shall be carried out on six tube assemblies. Immerse the samples in the bath at ambient temperature (avoiding contact between the fittings and the solution, see Figure 1) for  $(5 \pm 0,5)$  minutes. Place the tube assembly samples in a chamber at 60 °C with relative humidity greater than 85 % but avoiding condensation on the tube.

Repeat this immersion seven more times with an interval of 24 h between each immersion. One of the intervals may be of 72 h. Stop the test 24 h after the eighth immersion. Inspect the tubes for cracks and breaks.

Carry out the burst test at 23 °C in accordance with 9.1.2.

### 9.8.4 Requirements

At the end of the procedure described in 9.8.3 the samples shall show no cracks or breaks and the burst pressure shall be greater than 80 % of the reference value measured at 23 °C on samples from the same batch.

## 9.9 Resistance to ethanol

### 9.9.1 Test procedure

The test shall be carried out on three tube samples 300 mm minimum in length. Bend each sample  $\geq 180^\circ$  over a mandrel with a diameter  $10 \times$  the outer diameter of the tubing. Immerse the bent tube still on the mandrel in 95 % ethanol for 200 h at an ambient temperature of 23 °C. Remove the tube and straighten.

### 9.9.2 Requirement

The samples shall show no evidence of cracking.

## 9.10 Resistance to battery acid

### 9.10.1 Procedure

The test shall be carried out on three tube samples 300 mm minimum in length, sealed at each end. Weigh the samples and measure their length, inner and outer diameter.

Bend each sample  $\geq 180^\circ$  to a bend radius of  $11 \times$  the outer diameter of the tube or, if using a mandrel,  $10 \times$  the outer diameter of the tube and fix it. Immerse the bent samples for 70 h in dilute sulfuric acid of mass per unit volume  $1,275 \text{ g/cm}^3$  at a temperature of 23 °C. Remove the samples from the test liquid, rinse and wipe them thoroughly. Weigh and measure the samples again.

Assemble end fittings onto the tube sample and immediately perform the tensile test in accordance with Annex B.



### 9.10.2 Requirements

No dimensional change shall exceed  $\pm 2$  %.

Change in weight shall not exceed 2 %.

The tube shall show no evidence of cracking.

The samples shall withstand at least 80 % of the minimum applied tensile force given in Clause B.1.

## 9.11 Resistance to oil

### 9.11.1 Procedure

The test shall be carried out on either three 6 mm  $\times$  1 mm tube samples or three flat samples 25 mm wide, 1 mm thick and approximately 40 mm in length.

Determine the initial volume by the water displacement method according to ISO 1183-1, weighing to the nearest 1 mg. The water temperature shall be 23 °C.

Dry the test piece and place it in a container of oil with 10W40 synthetic oil. The oil additives shall be chemically inactive with respect to the thermoplastic material. Place the container in an oven at  $(70 \pm 2)$  °C for 70 h. At the end of the soaking period, allow the sample to cool to ambient temperature in the test liquid, remove and wipe all traces of test liquid from all surfaces.

Determine the final volume by the same method as before immersion.

### 9.11.2 Requirement

The average volume change shall not exceed 5 %.

## 9.12 Resistance to urea solution

### 9.12.1 Procedure

The test shall be carried out on three tube samples 300 mm minimum in length, sealed at each end.

Bend each sample  $\geq 180^\circ$  to a bend radius of  $11 \times$  the outer diameter of the tube or, if using a mandrel,  $10 \times$  the outer diameter of the tube, and fix it. Immerse the bent samples for 70 h in the Ad blue + denoxium water solution, as specified below, at a temperature of 23 °C. Remove the samples from the test liquid, rinse and wipe them thoroughly.

Specification Ad blue + denoxium water solution:

- 32,5 % urea solution in water;
- freezing point:  $-11$  °C;
- freezing point Ad blue + antifreeze denoxium:  $-30$  °C;
- decomposition temperature:  $> 70$  °C.

### 9.12.2 Requirement

The tube shall show no evidence of cracking.

## 9.13 Heat ageing

### 9.13.1 Procedure

The applied materials shall comply with this International Standard, including thermoplastic adhesive materials used to join together any dissimilar material layers.

### 9.13.2 Requirement

The long-term heat ageing test and properties are to be specified by the end user.

## 9.14 Artificial weathering test

### 9.14.1 Procedure

Use a suitable radiation source with reproducible spectrum and constant output as specified in ISO 4892-2, preferably a xenon arc test cabinet. The use of other cabinets using other types of light sources, for example an open-flame carbon arc, is in principle acceptable but shall be agreed upon between the tube manufacturer and the end user.

Place three samples of the tube of about 150 mm length facing the lamp, ensuring that there is no movement of the samples during the test.

Expose samples to radiation according to method A of ISO 4892-2:2006 or ISO 4892-4:2004 with 550 W/m<sup>2</sup> irradiance:

- a) for 750 h with the xenon arc lamp, at  $(65 \pm 3)$  °C or
- b) for 400 h with an open-flame carbon arc lamp, at  $(65 \pm 3)$  °C.

The test shall be carried out with water spray cycles,  $(18 \pm 0,5)$  min spraying time and  $(102 \pm 0,5)$  min dry interval, at a relative humidity of  $(65 \pm 5)$  % for the dry interval.

Remove the samples from the cabinet and then assemble with end fittings. Subject the samples to a burst test at a temperature of 23 °C (in accordance with 9.1.2).

### 9.14.2 Requirements

All samples shall withstand

- 4 000 kPa (40 bar) for 1 000 kPa (10 bar) tubes;
- 5 000 kPa (50 bar) for 1 250 kPa (12,5 bar) tubes;

and at least 80 % of the burst pressure at 23 °C initially measured on samples from the same batch.

The burst area shall be ductile. Brittle fractures shall be regarded as failures.

## 9.15 Ozone test

### 9.15.1 Procedure

Subject the air brake tube hose to an ozone concentration of 100 pphm for 70 h at 40 °C according to FMVSS No. 1060 where the hose is secured around a mandrel 10 × the outer diameter of the tube.

### 9.15.2 Requirement

The tube shall show no evidence of cracks when visually inspected under seven-power magnification.

### 9.16 Tube assemblies

These tests shall be performed with end fittings to be used on the specific installation. The same type of fittings shall be used throughout all tests on tube assemblies mentioned below.

For the purpose of these tests, the tube assembly samples shall be at least 72 h old. Unless otherwise stated, the tests are performed unpressurized at an ambient temperature of  $(23 \pm 2) ^\circ\text{C}$  and a relative humidity of  $(50 \pm 10) \%$ .

The list of tests to be performed on the tube assemblies is given in Table 6.

**Table 6 — Tube assemblies — List of tests**

Test item	Annex B clause
Pull out strength	B.1
Leak	B.2
Vibration	B.3
Pulsating pressure fatigue	B.4
Salt spray	B.5

**Annex A**  
(normative)

**Cold impact apparatus**

**A.1 Apparatus**

The apparatus shall be in accordance with ISO 179-1 with the following exceptions:

- two specimen supports shall be used to retain the tube;
- the supports shall be in accordance with Figure A.1 and Table A.1.

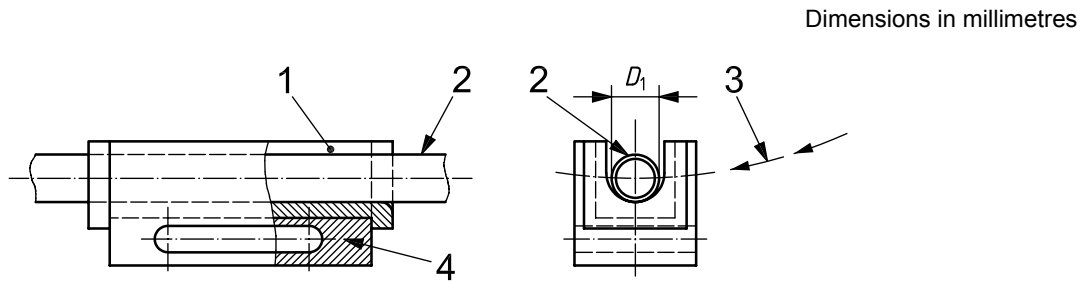

**a) Assembled support showing tube sample in position**

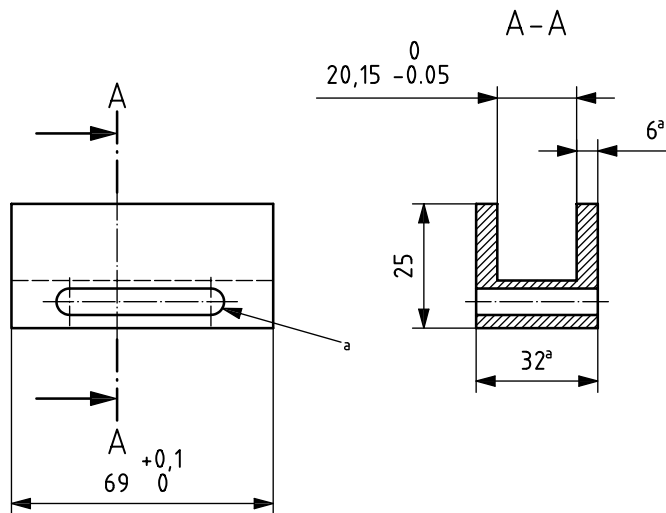

**b) Part 1 (material: general purpose steel with a tensile strength of 370 N/mm<sup>2</sup> to 450 N/mm<sup>2</sup>)**

**Figure A.1 (continued)**

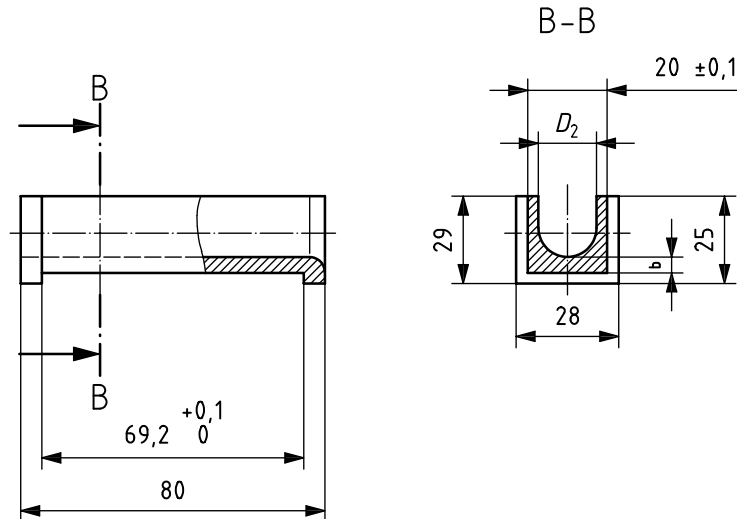

**c) Part 2 [material: e.g. polyamide (PA), polyester (TPC), epoxyplastic (EP)]**

**Key**

- 1 part 2
- 2 tube sample
- 3 pendulum swing
- 4 part 1

- a Dimensions 6 and 32 and the elongated hole may be changed to fit with any given apparatus.
- b Dimensions shall be such that the impact of the striking edge is in the centre of the specimen.

**Figure A.1 — Sample support**

**Table A.1 — Sample support, dimensions Figure A.1**

Dimensions in millimetres

$D_1$	4	6	8	12	16
$D_2$	7	9	9	17	17

The supports shall be firmly fixed to the lower part of the frame so that:

- a) the supporting surfaces of the two supports are in line with each other and perpendicular to the pendulum swing plane;
- b) the front ends of the supports with the radius of 4 mm face each other;
- c) the distance between supports is in accordance with Table A.2.

**Table A.2 — Distance between sample support, dimensions Figure A.1**

Dimensions in millimetres

$D_1$	4	6	8	12	16
<b>Distance between supports</b>	35	40	50	60	70

## ISO 7628:2010(E)

The supports shall be adjusted in such a way that the impact of the striking edge is in the middle of the two supports within  $\pm 0,5$  mm.

The test apparatus shall have the following characteristics:

- impact energy: 7,5 J;
- velocity at impact: 3,8 m/s ( $\pm 5$  %).

### A.2 Procedure

The test procedure shall be in accordance with ISO 179-1.

Furthermore, the specimens shall be straightened and kept in a straight position. Pins may be inserted to keep the specimen straight but must be removed before testing.

© ISO 2010 – All rights reserved

## Annex B (normative)

### Tests on tube assemblies (tube with end fittings)

#### B.1 Pull out test

##### B.1.1 Procedure

This test shall be conducted on three samples of tube assemblies. The tube length shall be 150 mm between the end fittings.

Prior to testing, the specimen shall be conditioned in an oven for 2 h at 80 °C, 100 °C or 125 °C, depending on the temperature class, and then cooled to room temperature.

A suitable tension testing machine with a suitable indication device shall be used for applying a tensile load at a constant rate of 25 mm/min and measuring the maximum load. The fixtures for holding the test specimens shall be arranged in such a way that the tubing and fittings have a straight centre line corresponding to the direction of the machine pull.

Grip the test specimen in the tensile-loading device and apply an axial tensile force at a speed of 25 mm/min until one of the following events occurs:

- a) the fitting or tube separates from the flexible tubing;
- b) one of the test specimen components breaks, fractures or ruptures;
- c) the load specified in Table B.1 is reached.

**Table B.1 — Minimum tensile force**

Nominal tubing size outside diameter mm	Wall thickness mm	Minimum tensile force N
4 × 1	1	180
6 × 1	1	290
8 × 1	1	400
9 × 1,5	1,5	650
10 × 1	1	520
10 × 1,25	1,25	630
11 × 1,5	1,5	820
12 × 1,5	1,5	900
14 × 2	2	1 380
15 × 1,5	1,5	1 160
16 × 2	2	1 600
18 × 2	2	1 830
19 × 2	2	1 950

##### B.1.2 Requirement

No loosening or pull off shall occur. Neither the tube nor the fittings shall fail.

## B.2 Leak test

### B.2.1 Procedure

The test shall be carried out on three tube assemblies and consists, depending on the temperature class, of a temperature cycle from 80 °C, 100 °C or 125 °C to –40 °C. The tube assemblies shall be held under pressure with inert gas or dry air. The free length of the tube shall be at least 150 mm.

Place three specimens with end fittings in a forced-circulation oven and heat at 80 °C, 100 °C or 125 °C depending on the temperature class. When the temperature is reached, subject the specimens to a test pressure of twice the working pressure for 5 min at the required temperature, 80 °C, 100 °C or 125 °C according to the temperature class. Cool and condition the test specimen for one hour at –40 °C. Subject the specimen to a test pressure of twice the working pressure for 5 min at –40 °C.

Condition the specimen at 23 °C for 1 h. Subject the specimens to the working pressure and check on leakage using leakage detection spray.

### B.2.2 Requirement

The test specimens shall show no leakage.

## B.3 Vibration test

A vibration test shall be performed on the tube assembly.

Until such time as appropriate test procedure(s) and performance requirement(s) have been agreed upon, it is necessary that either an existing national standard or a vehicle manufacturer's internal specification be used.

## B.4 Pulsating pressure fatigue test

### B.4.1 Procedure

This test shall be carried out on three tube assemblies where the pipe length between the pipe fittings shall be at least 300 mm. The test set-up is schematically shown in Figure B.1.

Test conditions:

- pressurizing medium: inert hydraulic fluid;
- outside medium: air;
- test pressure: from a value lower than 0,2 MPa (2 bar) to 133 % of the maximum working pressure;
- test frequency and number of cycles: to be agreed upon between customer and supplier.

Mount the pipe, in a horizontal or a vertical position, as shown in Figure B.1, allowing the pipe to move freely during the test. Apply pressure varying from a value lower than 0,2 MPa (2 bar) to 133 % of the maximum working pressure at  $(100 \pm 2)$  °C as agreed upon between customer and supplier.

On completion of the fatigue test, carry out a burst test on the tube assemblies at 23 °C, 80 °C, 100 °C or 125 °C in accordance with 9.1.

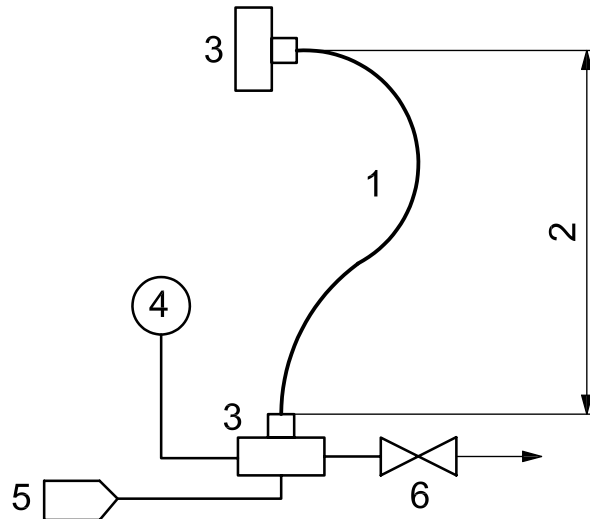

**Key**

1	pipe assembly	3	assembly frame	5	pump
2	length of pipe 270 mm	4	pressure gauge	6	valve

**Figure B.1 — Pulsating pressure fatigue test — schematic****B.4.2 Requirements**

The samples shall show no sign of failure or leakage after the fatigue test.

The burst criterion is the burst of the tube itself.

All five samples shall have a burst pressure as specified below and greater than 80 % of the reference value measured at 23 °C on samples from the same batch.

**Table B.2 — Burst pressure**

Test temperature	Tube class	Burst pressure
23 °C	1 000 kPa (10 bar)	> 4 000 kPa (40 bar)
	1 250 kPa (12,5 bar)	> 5 000 kPa (50 bar)
80 °C	1 000 kPa (10 bar)	> 2 500 kPa (25 bar)
100 °C	1 000 kPa (10 bar)	> 2 500 kPa (25 bar)
	1 250 kPa (12,5 bar)	> 3 150 kPa (31,5 bar)
125 °C	1 250 kPa (10 bar)	> 2500 kPa (25 bar)

**B.5 Salt spray test****B.5.1 Procedure**

This test shall be carried out on three tube assemblies and consists of an exposure to salt spray using ASTM B117 followed by an impact test in accordance with Annex A. The pipe length between the pipe fittings shall be at least 150 mm between the end fittings where the end fittings are closed. The exposure conditions shall be agreed upon between the customer and supplier.

**B.5.2 Requirement**

The tube shall show no evidence of cracking after the test.

## Annex C (informative)

### Method for leak detection in leak-proof testing

#### C.1 Apparatus

See Figures C.1 and C.2.

#### C.2 Procedure

Carry out the following operations to detect leaks in leak-proof (or pressure resistance) testing (see Annex B):

- a) select test chamber to suit tube size;
- b) remove test chamber end cap complete with glass sight tube;
- c) remove gland nut and silicone sealing ring;
- d) insert the tube sample to be tested with fitting already assembled into the test chamber;
- e) slide silicone sealing ring and gland nut on to the tube;
- f) position test fitting in chamber and tighten gland nut;
- g) examine silicone sealing ring on test chamber head then replace head and tighten;
- h) connect test assembly to a high-pressure line with a suitable adaptor;
- i) fill test chamber with oil and continue to flush oil through until as much air as possible is forced from test chamber;
- j) turn off oil discharge tap;
- k) with sight glass vertical, allow air in the oil to collect at top of sight glass;
- l) open vent valve at top of sight glass cover;
- m) pump more oil through until all air is removed from top of sight glass;
- n) close vent valve;
- o) insert test chamber into hot or cold chamber;
- p) carry out temperature test;
- q) open oil discharge tap;
- r) pressurize test tube to 150 % of the working pressure;
- s) observe if air bubbles appear in glass sight tube;
- t) fulfil test conditions as in Clause B.4;
- u) replace silicone sealing rings after 20 tests.

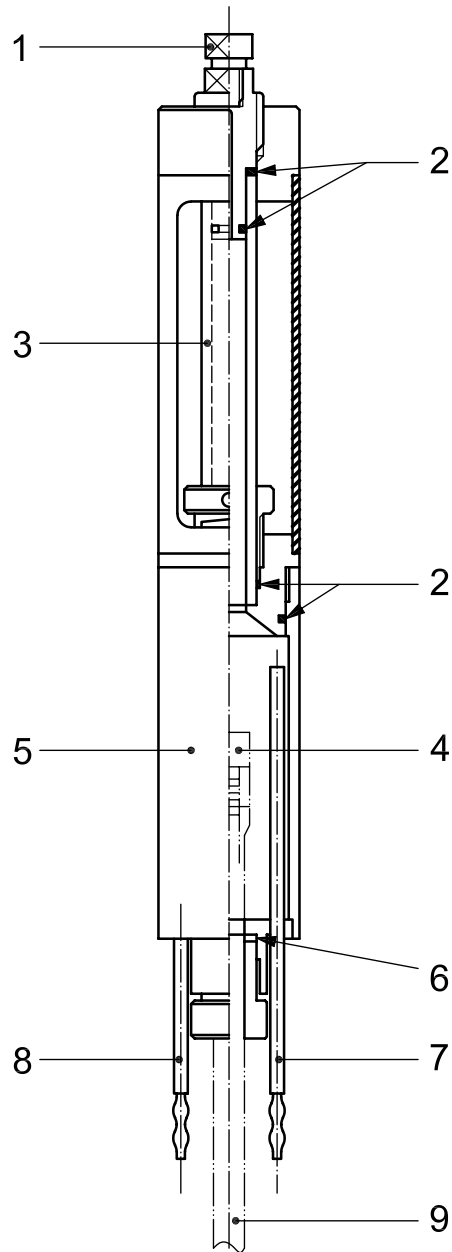

**Key**

- 1 air bleed screw
- 2 silicone seals
- 3 sight glass
- 4 test fitting
- 5 test chamber body
- 6 seals
- 7 bleed oil delivery pipe
- 8 bleed oil return pipe
- 9 test tube

**Figure C.1 — Apparatus for leak-proof test**

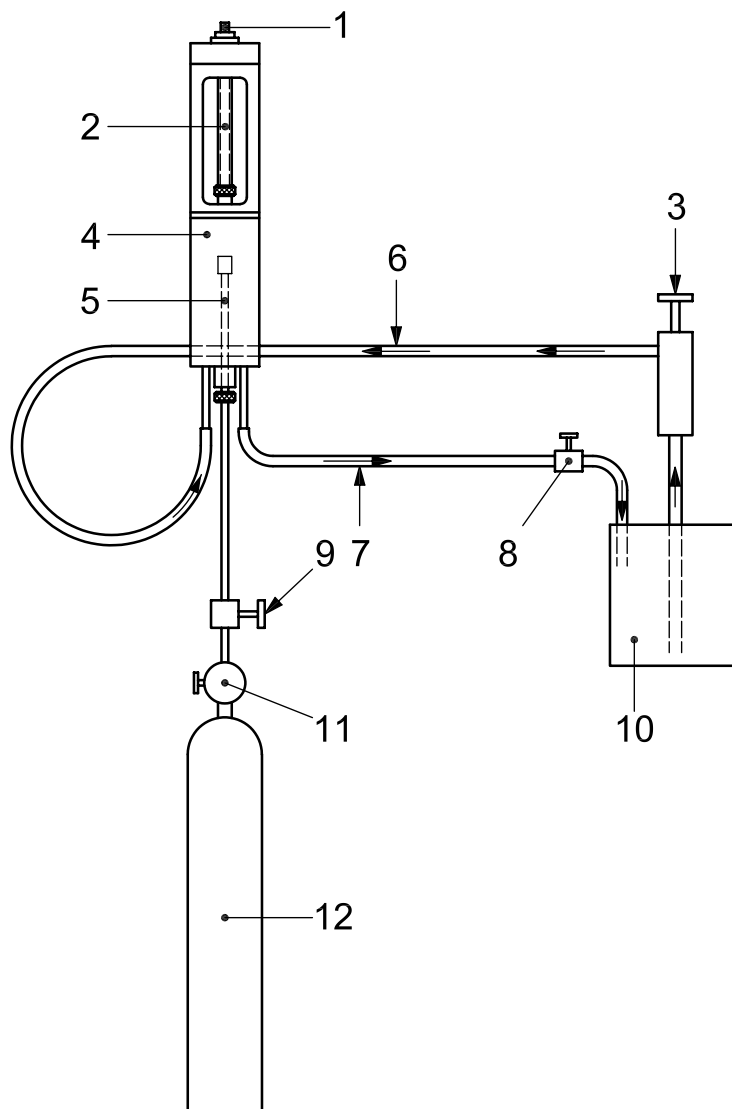

**Key**

- 1 air oil bleed screw
- 2 sight tube
- 3 oil hand pump bleed
- 4 test chamber
- 5 test tube
- 6 bleed oil delivery pipe
- 7 bleed oil return pipe
- 8 shut-off valve
- 9 high-pressure valve
- 10 oil tank
- 11 pressure reducer valve
- 12 neutral gas cylinder

**Figure C.2 — Leak-proof test assembly**

## Annex D (informative)

### Synopsis of test and corresponding samples

**Table D.1 — Test and corresponding samples**

Test	Clause/ subclause	Number of samples	Test without end fittings  Minimum length of sample	Test with end fittings  Length <sup>a</sup> between end fittings
Burst	9.1	5		150
Deformation under pressure	9.2	3 <sup>b</sup>		300
Cold impact	9.3	5 (10)	150 <sup>c</sup>	
Impact test after heat ageing	9.4	3	150	
Layer adhesion test multilayer pipes	9.5	5	150	
Moisture absorption	9.6	3	40	
Low temperature flexural	9.7	3	300 <sup>c</sup>	
Stress cracking	9.8	6	$4D + (11 \pi D)/2^d$ ( $D$ = nominal outside diameter)	
Resistance to ethanol	9.9	3	300 <sup>c</sup>	
Resistance to battery acid	9.10	3	300 <sup>c</sup>	
Resistance to oil	9.11	3	40 or flat samples 40 × 25 × 1 mm	
Resistance to urea solution	9.12	3	300 <sup>c</sup>	
Heat ageing	9.13	2	End user specification	
Artificial weathering	9.14	3	150	
Ozone	9.15		$8 \pi D^d$ ( $D$ = nominal outside diameter)	
Pull out	B.1	3		150
Leak	B.2	3		150
Vibration	B.3			End user's specification
Pulsating pressure fatigue	B.4	3		300
Salt spray	B.5	3		150
<sup>a</sup> Values given as an indication, except for pull out test. <sup>b</sup> These samples shall be conditioned before testing. <sup>c</sup> These values are minimums. <sup>d</sup> The length depends upon the diameter of the tube.				

## Bibliography

- [1] ISO 307, *Plastics — Polyamides — Determination of viscosity number*
- [2] ISO 527-2, *Plastics — Determination of tensile properties — Part 2: Test conditions for moulding and extrusion plastics*
- [3] ISO 1133-1, *Plastics — Determination of the melt volume-flow rate (MVR) and melt mass-flow rate (MFR) of thermoplastics materials — Part 1: Standard method*
- [4] ISO 1133-2, *Plastics — Determination of the melt volume-flow rate (MVR) and melt mass-flow rate (MFR) of thermoplastics materials — Part 2: Method for materials sensitive to time-temperature history and/or moisture*
- [5] ISO 1874-1, *Plastics — Polyamide (PA) moulding and extrusion materials — Part 1: Designation*
- [6] ISO 1874-2, *Plastics — Polyamide (PA) moulding and extrusion materials — Part 2: Preparation of test specimens and determination of properties*
- [7] ISO 2719, *Determination of flash point — Pensky-Martens closed cup method*
- [8] ISO 2977, *Petroleum products and hydrocarbon solvents — Determination of aniline point and mixed aniline point*
- [9] ISO 3104, *Petroleum products — Transparent and opaque liquids — Determination of kinematic viscosity and calculation of dynamic viscosity*
- [10] ISO 3146, *Plastics — Determination of melting behaviour (melting temperature or melting range) of semi-crystalline polymers by capillary tube and polarizing-microscope methods*
- [11] ISO 3795, *Road vehicles, and tractors and machinery for agriculture and forestry — Determination of burning behaviour of interior materials*
- [12] ISO 4080, *Rubber and plastics hoses and hose assemblies — Determination of permeability to gas*
- [13] ISO 6427, *Plastics — Determination of matter extractable by organic solvents (conventional methods)*
- [14] ISO 7375-1, *Road vehicles — Coiled pipe assemblies for pneumatic braking connection between motor vehicles and towed vehicles — Part 1: Dimensions*
- [15] ISO 7375-2, *Road vehicles — Coiled tube assemblies for air brake connection between towing and towed vehicles — Part 2: Performance requirements*
- [16] ISO 14910-1, *Plastics — Thermoplastic polyester/ester and polyether/ester elastomers for moulding and extrusion — Part 1: Designation system and basis for specifications*
- [17] ISO 14910-2, *Plastics — Thermoplastic polyester/ester and polyether/ester elastomers for moulding and extrusion — Part 2: Preparation of test specimens and determination of properties*
- [18] SAE J1131:1997, *Performance Requirements For SAE J844 Nonmetallic Tubing and Fitting Assemblies Used in Automotive Air Brake Systems*
- [19] SAE J2260, *Nonmetallic Fuel System Tubing with One or More Layers*



---

---

**ICS 43.040.40; 83.140.30**

Price based on 26 pages