

---

---

**Plastics-coated fabrics for upholstery —  
Part 2:  
Specification for PVC-coated woven  
fabrics**

*Supports textiles revêtus de plastique pour ameublement et garniture —  
Partie 2: Spécifications pour les tissus revêtus de PVC*

---

---

Reference number  
ISO 7617-2:2003(E)

**PDF disclaimer**

This PDF file may contain embedded typefaces. In accordance with Adobe's licensing policy, this file may be printed or viewed but shall not be edited unless the typefaces which are embedded are licensed to and installed on the computer performing the editing. In downloading this file, parties accept therein the responsibility of not infringing Adobe's licensing policy. The ISO Central Secretariat accepts no liability in this area.

Adobe is a trademark of Adobe Systems Incorporated.

Details of the software products used to create this PDF file can be found in the General Info relative to the file; the PDF-creation parameters were optimized for printing. Every care has been taken to ensure that the file is suitable for use by ISO member bodies. In the unlikely event that a problem relating to it is found, please inform the Central Secretariat at the address given below.

© ISO 2003

All rights reserved. Unless otherwise specified, no part of this publication may be reproduced or utilized in any form or by any means, electronic or mechanical, including photocopying and microfilm, without permission in writing from either ISO at the address below or ISO's member body in the country of the requester.

ISO copyright office  
Case postale 56 • CH-1211 Geneva 20  
Tel. + 41 22 749 01 11  
Fax + 41 22 749 09 47  
E-mail [copyright@iso.org](mailto:copyright@iso.org)  
Web [www.iso.org](http://www.iso.org)

Published in Switzerland

## Contents

	Page
<b>1 Scope</b> .....	<b>1</b>
<b>2 Normative references</b> .....	<b>1</b>
<b>3 Technical requirements</b> .....	<b>1</b>
<b>4 Sampling</b> .....	<b>2</b>
<b>5 Testing and compliance</b> .....	<b>2</b>
<b>6 Marking</b> .....	<b>3</b>
<b>Annex A (normative) Method of selecting test specimens</b> .....	<b>4</b>
<b>Annex B (normative) Determination of resistance to print wear</b> .....	<b>6</b>
<b>Annex C (normative) Determination of colour fastness to rubbing</b> .....	<b>8</b>

## Foreword

ISO (the International Organization for Standardization) is a worldwide federation of national standards bodies (ISO member bodies). The work of preparing International Standards is normally carried out through ISO technical committees. Each member body interested in a subject for which a technical committee has been established has the right to be represented on that committee. International organizations, governmental and non-governmental, in liaison with ISO, also take part in the work. ISO collaborates closely with the International Electrotechnical Commission (IEC) on all matters of electrotechnical standardization.

International Standards are drafted in accordance with the rules given in the ISO/IEC Directives, Part 2.

The main task of technical committees is to prepare International Standards. Draft International Standards adopted by the technical committees are circulated to the member bodies for voting. Publication as an International Standard requires approval by at least 75 % of the member bodies casting a vote.

Attention is drawn to the possibility that some of the elements of this document may be the subject of patent rights. ISO shall not be held responsible for identifying any or all such patent rights.

ISO 7617-2 was prepared by Technical Committee ISO/TC 45, *Rubber and rubber products*, Subcommittee SC 4, *Products (other than hoses)*.

This third edition cancels and replaces the second edition (ISO 7617-2:1994), which has been technically revised.

ISO 7617 consists of the following parts, under the general title *Plastics-coated fabrics for upholstery*:

- *Part 1: Specification for PVC-coated knitted fabrics*
- *Part 2: Specification for PVC-coated woven fabrics*
- *Part 3: Specification for polyurethane-coated woven fabrics*

# Plastics-coated fabrics for upholstery —

## Part 2: Specification for PVC-coated woven fabrics

### 1 Scope

This part of ISO 7617 specifies requirements for coated fabrics for upholstered furniture, manufactured by applying to one side of a woven cloth a substantially continuous coating of a suitably plasticized polymer of vinyl chloride, or a copolymer the major constituent of which is vinyl chloride. Such coatings are known as poly(vinyl chloride) (PVC) coatings. The present specification covers two grades (A and B) of PVC-coated woven fabric.

### 2 Normative references

The following referenced documents are indispensable for the application of this document. For dated references, only the edition cited applies. For undated references, the latest edition of the referenced document (including any amendments) applies.

ISO 105-A02:1993, *Textiles — Tests for colour fastness — Part A02: Grey scale for assessing change in colour*

ISO 105-B01:1994, *Textiles — Tests for colour fastness — Part B01: Colour fastness to light: Daylight*

ISO 105-B02:1994, *Textiles — Tests for colour fastness — Part B02: Colour fastness to artificial light: Xenon arc fading lamp test*

ISO 105-X12:2001, *Textiles — Tests for colour fastness — Part X12: Colour fastness to rubbing*

ISO 176:1976, *Plastics — Determination of loss of plasticizers — Activated carbon method*

ISO 1421:1998, *Rubber- or plastics-coated fabrics — Determination of tensile strength and elongation at break*

ISO 2231:1989, *Rubber- or plastics-coated fabrics — Standard atmospheres for conditioning and testing*

ISO 2286-1:1998, *Rubber- or plastics-coated fabrics — Determination of roll characteristics — Part 1: Methods for determination of length, width and net mass*

ISO 2411:2000, *Rubber- or plastics-coated fabrics — Determination of coating adhesion*

ISO 4674-1:2003, *Rubber- or plastics-coated fabrics — Determination of tear resistance — Part 1: Constant rate of tear methods*

ISO 5978:1990, *Rubber- or plastics-coated fabrics — Determination of blocking resistance*

ISO 7854:1995, *Rubber- or plastics-coated fabrics — Determination of resistance to damage by flexing*

### 3 Technical requirements

#### 3.1 Physical requirements

The material shall comply with the appropriate requirements of Table 1.

### 3.2 Colour fastness requirements

The material shall comply with the requirements of Table 2.

### 3.3 Visual examination

The coating of the material shall be uniformly applied and shall be free from visible flaws and cracks and when viewed under a magnification of  $\times 10$  shall be substantially free from pinholes. The base fabric, unless coated with an unpigmented coating, shall not be visible when viewed from the coated side.

### 3.4 Colour, grain and finish

The colour, grain and finish of the material, whether in single-colour or multicolour effects, shall be agreed between the purchaser and the supplier.

Colours shall be compared under the conditions stipulated in ISO 105-B01.

### 3.5 Width of material

The usable width of material when measured in accordance with ISO 2286-1 shall be as agreed between the purchaser and the supplier. For this purpose, the term "usable width" means the width of material that is coated in such a manner that it complies with the requirements of 3.3.

### 3.6 Flammability

A method of test for determination of the flammability characteristics of these materials shall be included as a mandatory requirement to be complied with in the absence of other, more stringent, requirements of national authorities.

## 4 Sampling

If individual rolls can be identified with manufacturing batches, at least one sample shall be taken from each batch in the consignment. Each sample shall be regarded as being representative of its source, and suitable measures shall be taken to preserve identity between the samples and batch numbers.

If individual rolls cannot be identified in this way, the number of samples to be regarded as being representative of the bulk shall be fixed by agreement between the purchaser and the supplier. Such samples shall be drawn at random.

## 5 Testing and compliance

Tests shall be conducted on a set of specimens selected from each sample.

The method of selecting specimens from each sample shall be in accordance with the requirements of Annex A. If the specimens after testing comply with the appropriate requirements given in Tables 1 and 2, the bulk of the coated fabric which the sample represents shall be deemed to comply with the requirements of this part of ISO 7617.

If any of the specimens tested do not comply with any of the appropriate requirements given in Tables 1 and 2, the tests which the specimens have failed shall be repeated twice. For this purpose, two further samples shall be taken from the same source as the original sample, and test specimens shall be taken from each sample so that duplicate tests may be conducted. If all the re-test results comply with the appropriate requirements of Table 1 and/or Table 2, then the bulk represented by the samples from which the specimens for re-testing were taken, together with the original samples, shall be deemed to comply with the requirements of this part of ISO 7617. If any of the results of the re-tests do not comply with the appropriate requirements of Table 1 or 2,

the bulk represented by those samples shall be deemed not to comply with the requirements of this part of ISO 7617.

**Table 1 — Physical requirements**

Property	Limit	Requirements		Method of test
		Grade A	Grade B	
Total mass/unit area (g/m <sup>2</sup> ) <sup>a</sup>	min.	550	420	ISO 2286-1
Coating mass/unit area (g/m <sup>2</sup> ) <sup>a</sup>	min.	300	240	ISO 2286-1
Tearing force (N)				ISO 4674-1:2003, method A
longitudinal	min.	44	31	
transverse	min.	44	31	
Coating adhesion (N per 50 mm width)	min.	26	26	ISO 2411
Breaking load (N)				ISO 1421:1998, method 2
longitudinal	min.	580	450	
transverse	min.	580	450	
Flex cracking (cycles) <sup>b</sup>	min.	400 000	300 000	ISO 7854
Heat ageing (% coating mass loss)	max.	5	5	ISO 176
Print wear (change in appearance) (grey scale rating)	min.	3	3	See Annex B
Thickness (mm) at 2 kPa, minimum individual reading	min.	0,4	0,4	ISO 2286-1
Blocking resistance		Separation without damage to surface		ISO 5978
<p><sup>a</sup> The inclusion of minimum values for total mass/unit area and coating mass/unit area does not imply that a minimum value for base fabric mass/unit area may be calculated by subtraction.</p> <p><sup>b</sup> In the event of dispute, Schildknecht apparatus shall be employed.</p>				

**Table 2 — Colour fastness requirements**

Property	Limit	Requirements		Method of test
		Grade A	Grade B	
Colour-fastness				
to artificial light (xenon arc)	min.	6	6	ISO 105-B02
to rubbing (wet and dry)	min.	4	4	See Annex C

## 6 Marking

Each roll of fabric shall have a label attached bearing the following information:

- the name and/or distinctive mark of the manufacturer and an identification reference for that material;
- the batch number;
- the colour;
- the length;
- the usable width;
- the reference number of this part of ISO 7617 (i.e. ISO 7617-2) and the appropriate grade reference.

## **Annex A** (normative)

### **Method of selecting test specimens**

The specimens for testing shall be selected from the sample in accordance with the scheme illustrated in Figure A.1, which shows the positions from which the specimens for each type of test shall be taken, except that the specimens required for testing colour fastness to light and those required for heat ageing tests shall be selected from any suitable portion of the sample. In the case of multicolour samples, the specimen shall if possible include all colours. If it is not possible to include all colours, sufficient specimens shall be taken to enable all colours to be tested.



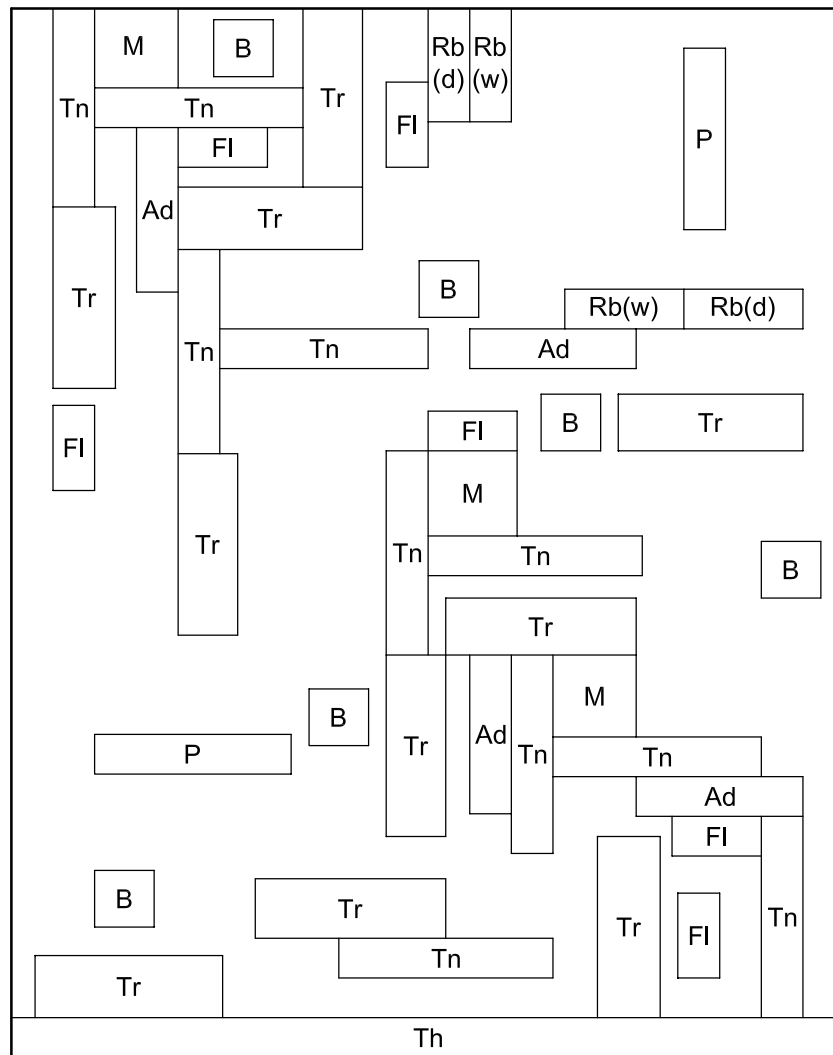

**Key**

- M mass determinations
- Tr tear strength (across longitudinal threads)
- Tr tear strength (across transverse threads)
- Tn breaking load (longitudinal)
- Tn breaking load (transverse)
- Ad coating adhesion
- FI resistance to flex cracking (longitudinal direction)
- FI resistance to flex cracking (transverse direction)
- heat ageing (any convenient location)
- Rb(w) colour fastness to rubbing (wet)
- Rb(d) colour fastness to rubbing (dry)
- P print wear (2 pieces, 230 mm × 50 mm)
- B blocking resistance
- Th thickness determination

**Figure A.1 — Scheme for selection of test specimens**

## Annex B (normative)

### Determination of resistance to print wear

#### B.1 Principle

A specimen is subjected to 500 cycles of simple harmonic abrasion using a known abradant under a known pressure. It is then assessed for colour difference with an unabraded portion using the grey scale for assessing change in colour.

#### B.2 Apparatus

The apparatus shall be as described in ISO 105-X12, but with the following modifications:

- a) The weightpiece applied to the rubbing finger, or peg, shall be such that a total mass of 1 500 g is brought to bear on the glass plate.
- b) The frequency of operation of the apparatus shall be 0,25 Hz (i.e. 0,5 strokes per second: each cycle comprises one outward stroke and one return stroke).
- c) Use as the abradant a cotton fabric, desized scoured and bleached, free from fluorescent brightening agents, and having a fluidity no greater than 8, a mass per unit area of 93 g/m<sup>2</sup> and a construction of 40 ends/cm, 39 picks/cm, 11,36 tex warp and 9,23 tex weft in plain weave.
- d) Use the grey scale for assessing change in colour (see ISO 105-A02).

#### B.3 Test specimens

Cut out two specimens of coated fabric, each 230 mm × 50 mm, one with its length parallel to the longitudinal direction of the sample and the other with its length parallel to the transverse direction. Also cut out two circular pieces of the bleached cotton fabric, each 30 mm in diameter, avoiding lumps and neps.

NOTE Initially, four circular pieces of abradant cotton fabric can be cut out and a double thickness of cotton mounted on the peg, so that only the outermost layer coming into contact with the coated-fabric specimen needs to be renewed at each test.

#### B.4 Procedure

Condition the test specimens and bleached cotton fabric in accordance with ISO 2231.

Using the clamps, mount the test specimen securely on the bed of the machine with the coated side uppermost and under sufficient tension to hold the specimen flat.

Wipe the coated surface of the specimen with a clean, dry cloth to remove dust before testing.

Secure the conditioned bleached cotton fabric to base of the brass peg, making sure that the face of the sateen is presented to the specimen under test, i.e. with the ribbed side of the bleached cotton fabric in contact with the brass peg. Lower the peg on to the specimen and run the machine for 500 cycles. Repeat the procedure using the second specimen and bleached cotton fabric.

Assess the degree of surface print wear on the specimens, using the grey scale as comparator in accordance with ISO 105-A02. If one specimen exhibits greater print wear than the other, the worse result of the two shall be taken as the test result.

## B.5 Expression of results

Report the change in colour between the abraded and unabraded portions of the test specimen by reference to the grey scale for assessing change in colour.

## **Annex C** (normative)

### **Determination of colour fastness to rubbing**

The method of test shall be as specified in ISO 105-X12 but with the following changes:

- a) the frequency of operation of the apparatus shall be 0,25 Hz (i.e. 0,5 strokes per second: each cycle comprises one outward stroke and one return stroke);
- b) the number of strokes shall be 20 (10 outward and 10 return);
- c) the rubbing of the fabric shall be carried out as specified in Annex B of this part of ISO 7617.

www.iso.org

---

---

**ICS 59.080.40; 97.140**

Price based on 8 pages