

---

---

**Plastics piping systems — Glass-reinforced  
thermosetting plastics (GRP) pipes —  
Determination of time to failure under  
sustained internal pressure**

*Systèmes de canalisations en plastiques — Tubes en plastiques  
thermodurcissables renforcés de verre (PRV) — Détermination du temps  
mis jusqu'à la défaillance sous une pression interne constante*



**PDF disclaimer**

This PDF file may contain embedded typefaces. In accordance with Adobe's licensing policy, this file may be printed or viewed but shall not be edited unless the typefaces which are embedded are licensed to and installed on the computer performing the editing. In downloading this file, parties accept therein the responsibility of not infringing Adobe's licensing policy. The ISO Central Secretariat accepts no liability in this area.

Adobe is a trademark of Adobe Systems Incorporated.

Details of the software products used to create this PDF file can be found in the General Info relative to the file; the PDF-creation parameters were optimized for printing. Every care has been taken to ensure that the file is suitable for use by ISO member bodies. In the unlikely event that a problem relating to it is found, please inform the Central Secretariat at the address given below.

© ISO 2000

All rights reserved. Unless otherwise specified, no part of this publication may be reproduced or utilized in any form or by any means, electronic or mechanical, including photocopying and microfilm, without permission in writing from either ISO at the address below or ISO's member body in the country of the requester.

ISO copyright office  
Case postale 56 • CH-1211 Geneva 20  
Tel. + 41 22 749 01 11  
Fax + 41 22 749 09 47  
E-mail [copyright@iso.ch](mailto:copyright@iso.ch)  
Web [www.iso.ch](http://www.iso.ch)

Printed in Switzerland

## Foreword

ISO (the International Organization for Standardization) is a worldwide federation of national standards bodies (ISO member bodies). The work of preparing International Standards is normally carried out through ISO technical committees. Each member body interested in a subject for which a technical committee has been established has the right to be represented on that committee. International organizations, governmental and non-governmental, in liaison with ISO, also take part in the work. ISO collaborates closely with the International Electrotechnical Commission (IEC) on all matters of electrotechnical standardization.

International Standards are drafted in accordance with the rules given in the ISO/IEC Directives, Part 3.

Draft International Standards adopted by the technical committees are circulated to the member bodies for voting. Publication as an International Standard requires approval by at least 75 % of the member bodies casting a vote.

Attention is drawn to the possibility that some of the elements of this International Standard may be the subject of patent rights. ISO shall not be held responsible for identifying any or all such patent rights.

International Standard ISO 7509 was prepared by Technical Committee ISO/TC 138, *Plastics pipes, fittings and valves for the transport of fluids*, Subcommittee SC 6, *Reinforced plastics pipes and fittings for all applications*.

## Introduction

This International Standard describes a method for determining the time to failure under sustained internal pressure of glass-reinforced thermosetting plastics (GRP) pipes.

The method uses the following conditions:

- water as the reference liquid inside the test piece;
- air (method A) or water (method B) as the environment outside the test piece.

The method can be used for tests at different temperatures. It should be noted that, for a given temperature, the results obtained can differ depending on the end-sealing device and whether the external environment is water or air.

The method described in this International Standard differs from those in some other similar standards in the following details:

- the failure criteria and the detection of failure;
- the strain in the longitudinal and circumferential directions may be measured during the test;
- the test pressure is maintained constant.

This method may be used to obtain data to establish internal pressure versus time-to-failure relationships at different temperatures. The procedures for establishing the relationships are not within the scope of this International Standard. For such purposes attention is drawn to ISO 10928.

# Plastics piping systems — Glass-reinforced thermosetting plastics (GRP) pipes — Determination of time to failure under sustained internal pressure

## 1 Scope

This International Standard specifies a method for determining the time to failure of glass-reinforced thermosetting plastics (GRP) pipes under internal hydrostatic pressure at a specified temperature. The external environment may be air (method A) or water (method B).

NOTE For other internal or external environments, the referring standard should specify any additional requirement.

## 2 Normative reference

The following normative document contains provisions which, through reference in this text, constitute provisions of this International Standard. For dated references, subsequent amendments to, or revisions of, any of these publications do not apply. However, parties to agreements based on this International Standard are encouraged to investigate the possibility of applying the most recent edition of the normative document indicated below. For undated references, the latest edition of the normative document referred to applies. Members of ISO and IEC maintain registers of currently valid International Standards.

ISO 10928, *Plastics piping systems — Glass-reinforced thermosetting plastics (GRP) pipes and fittings — Methods for regression analysis and their use.*

## 3 Terms and definitions

For the purposes of this International Standard, the following terms and definitions apply.

### 3.1

#### **failure**

occurrence of bursting, leaking, weeping or pressure loss

### 3.2

#### **bursting**

rupture of the pipe wall with immediate loss of water

### 3.3

#### **leaking**

transmission of water through the wall of a test piece to an extent detectable visually

### 3.4

#### **pressure loss**

continuous loss of pressure of greater than 2 % per hour of the set pressure when measured over two consecutive hours on an isolated (e.g. non-pressure-adjusted) test specimen

## 4 Principle

### 4.1 General

A test piece at the required temperature is subjected to a specified internal hydrostatic pressure to cause a state of stress in the pipe wall which depends upon the loading conditions, i.e. with or without the effects of end thrust being carried by the pipe wall.

In general, a series of tests are conducted over various failure times and the results obtained analysed in accordance with ISO 10928 to establish a value. The number of tests required, the appropriate time intervals and the time at which a value is established are given in the referring standard.

It is assumed that the following test parameters are set by the standard making reference to this International Standard:

- a) whether the test piece is tested with or without hydrostatic end thrusts;
- b) the test temperature and its tolerance;
- c) the free length of the test piece;
- d) the number of test pieces;
- e) if and what strain measurements are required;
- f) the external environment;
- g) the limiting times to failure for the test.

Two methods of test depending on the external environment and failure determination are available.

### 4.2 Method A

Air is the environment outside the test piece. Failure may be determined by bursting, weeping or leaking, or by pressure loss.

### 4.3 Method B

Water is the environment outside the test piece. Failure may be determined by bursting or by pressure loss.

## 5 Apparatus

**5.1 Dimension-measuring devices**, capable of determining the dimensions (length, diameters, wall thickness) to an accuracy of within  $\pm 1,0\%$ .

**5.2 End-sealing devices** for the test piece, such that hydrostatic end thrust is or is not applied to the pipe wall (see Figure 1).

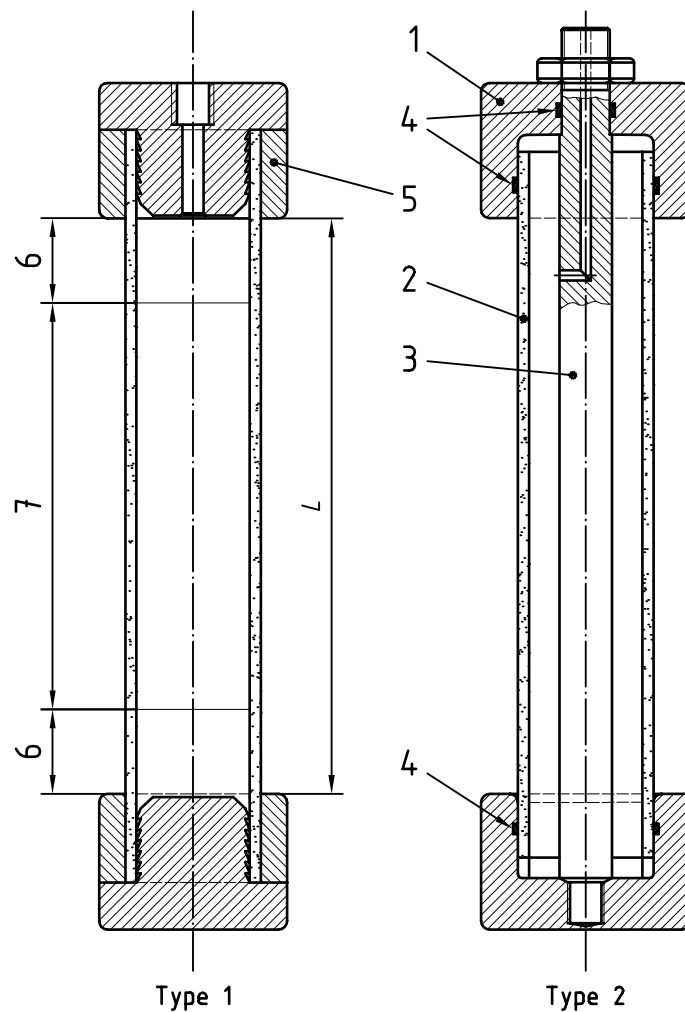
**Key**

- 1 End cap
- 2 Test piece
- 3 Tie bar carrying end thrust
- 4 Elastomeric seal
- 5 End-sealing device
- 6 See 8.5 for this dimension
- 7 Valid failure zone
- $L$  Length of test piece

Type 1: Testing with end thrust (external seals)

Type 2: Testing without end thrust (internal seals)

**Figure 1 — Typical arrangement for pressure testing of pipes**

**5.3 Test piece support(s)**, as necessary to minimize deformation of the test piece due to its own weight. Such support(s) shall not constrain the test piece circumferentially or longitudinally.

**5.4** If required (method B), a **container for water**, equipped so that the test temperature can be maintained uniform throughout the liquid.

NOTE This may require circulation.

**5.5 Pressurizing system**, capable of applying the pressure to the water in the test piece in such a way as to avoid entrapment of air.

The system shall be capable of maintaining the pressure within the limits detailed in 8.4 for the duration of the test.

The pressure should, preferably, be applied individually to each test piece. However, the use of equipment enabling the pressure to be applied simultaneously to several test pieces is also permitted if there is no danger of interference when failure occurs.

An automatic system may be used which adjusts the pressure to keep it within the specified limits.

**5.6 Pressure-measuring system**, capable of showing conformity to 8.4.

**5.7** If required, **strain-measuring device(s)**, capable of measuring the required strain to an accuracy of within  $\pm 2\%$ .

**5.8 Timing device(s)**, capable of recording the time elapsed to failure.

## 6 Test pieces

### 6.1 Free length

Each test piece shall comprise a full section of the pipe, the free length  $L$  of which, between the sealing devices, shall be as specified in the referring standard (see Figure 1).

### 6.2 Cutting

The ends shall be smooth and perpendicular to the axis of the pipe.

### 6.3 Number

The number of test pieces shall be as specified in the referring standard.

## 7 Conditioning

Unless otherwise specified by the referring standard, store the test piece(s) at the test temperature (see 8.1) for 24 h prior to testing.

## 8 Procedure

**8.1** Conduct the procedure given in 8.2 to 8.4 at the test temperature specified in the referring standard.

**8.2** If strain measurements are required, attach suitable gauges or equipment conforming to 5.7.

**8.3** Attach the end-sealing devices (see 5.2) to the test piece (see clause 6) and fill the assembly completely with the water. Attach the test piece to the pressurising system, avoiding entrapment of air.

If testing by method B, install the test piece in the container (see 5.4) so that it is totally surrounded with water.

NOTE Adjustments to the sequence may be made to accommodate apparatus or conditions.

**8.4** Raise the pressure to the required level within 5 min and maintain within  $\pm 2\%$  until failure. Record the period during which the test piece has been subjected to the test pressure, to an accuracy of  $\pm 2\%$ , in hours.



**8.5** The result of the test may be disregarded if the failure can be shown to have occurred outside of the valid failure zone; i.e. within a distance from an end-sealing device of

$$3,3 \times (DN \times e)^{0,5}$$

where

DN is the nominal size of the pipe, in millimetres;

e is the wall thickness of the pipe, in millimetres.

## 9 Test report

The test report shall include the following information:

- a) a reference to this International Standard and the referring standard;
- b) all details necessary for full identification of the pipes tested;
- c) the dimensions of each test piece;
- d) the number of test pieces;
- e) the operating limits of the pressurizing system (5.5);
- f) if required, the measured strains;
- g) the range of temperature during testing;
- h) the external environment used (method A or method B);
- i) the state of stress (i.e. with or without hydrostatic end thrust — see 5.2);
- j) the length of the valid failure zone (see Figure 1);
- k) the type of end-sealing device used (see Figure 1);
- l) if used, details of the test piece support (5.3);
- m) the test pressure for each test piece;
- n) for each test piece, either the time to failure or the duration of test (see 8.4);
- o) for each test piece, an image (e.g. sketch or photograph) showing the nature and position of the failure points;
- p) the failure mode for each test piece;
- q) any observations made during and after the test;
- r) any factors which may have affected the results, such as any operating details not specified in this International Standard;
- s) the date of the test or the dates between which the test was conducted.

---

---

**ICS 23.040.20**

Price based on 5 pages