

7505-86

4851903 0055987 T

P-07-04

International Standard



7505

INTERNATIONAL ORGANIZATION FOR STANDARDIZATION • МЕЖДУНАРОДНАЯ ОРГАНИЗАЦИЯ ПО СТАНДАРТИЗАЦИИ • ORGANISATION INTERNATIONALE DE NORMALISATION

**Forestry machinery — Chain saws — Measurement
of hand-transmitted vibration**

Machines forestières — Scies à chaîne — Mesurage des vibrations transmises aux mains

First edition — 1986-05-01

ISO 7505-1986 (E)

UDC 630*822:621.936.6

Ref. No. ISO 7505-1986 (E)

Descriptors : forest equipment, saws, measurement, vibration.

Price based on 8 pages

Foreword

ISO (the International Organization for Standardization) is a worldwide federation of national standards bodies (ISO member bodies). The work of preparing International Standards is normally carried out through ISO technical committees. Each member body interested in a subject for which a technical committee has been established has the right to be represented on that committee. International organizations, governmental and non-governmental, in liaison with ISO, also take part in the work.

Draft International Standards adopted by the technical committees are circulated to the member bodies for approval before their acceptance as International Standards by the ISO Council. They are approved in accordance with ISO procedures requiring at least 75 % approval by the member bodies voting.

International Standard ISO 7505 was prepared by Technical Committee ISO/TC 23, *Tractors and machinery for agriculture and forestry*.

Users should note that all International Standards undergo revision from time to time and that any reference made herein to any other International Standard implies its latest edition, unless otherwise stated.

© International Organization for Standardization, 1986 •

Printed in Switzerland

Forestry machinery — Chain saws — Measurement of hand-transmitted vibration

1 Scope and field of application

This International Standard specifies general methods for data acquisition and processing concerning hand-transmitted vibrations induced by portable chain saws. The methods are valid irrespective of how the chain saw is operated during the test, for example, whether it is hand-held or fitted in a stand, and whether it is cutting a log or not.

This International Standard specifies an operator hand-held procedure for acquisition of vibration data from portable chain saws.

NOTES

1 The hand-arm system exerts an influence on the hand-transmitted vibration and different hands and grips exert different influences. Therefore, the development of a standardized stand for holding the saw during the measurement is planned. The development of such stands is in progress.

2 The measurements in the three axes shall be made at, or clearly related to, the surface of the hand where the energy enters the body.

As the hands of the person are in direct contact with the vibrating surface of the hand-grip, the transducer should be fastened to the vibrating structure.

This International Standard is primarily intended for user and manufacturer purposes.

2 References

ISO 5347, *Methods of calibration of vibration and shock pickups*.¹⁾

ISO 5348, *Mechanical vibration and shock — Mechanical mounting of accelerometers*.¹⁾

ISO 6349, *Guidelines for the measurement and the assessment of human exposure to hand-transmitted vibration*.

ISO 6531, *Machinery for forestry — Portable chain saws — Vocabulary*.

IEC Publication 651, *Sound level meters*.

1) At present at the stage of draft.

ISO 7505-1986 (E)

3 Data acquisition and processing

3.1 Weighted acceleration sum

The acceleration in three perpendicular directions (defined in clause 4) shall be picked up by accelerometers and processed to form an overall vibration value, the weighted acceleration sum ($\bar{a}_{h,w}$), according to figure 1. Mathematically $\bar{a}_{h,w}$ is the mean square of the root (RMS) of the weighted signals from each direction. The weighting filters shall have the characteristics given in ISO 5349. (The definition of the weighting filter is given in the annex.)

NOTES

- 1 $\bar{a}_{h,w}$ can be calculated from frequency spectra of 1/3 octave or 1/1 octave with the weighting factors for the mid-frequencies calculated from ISO 5349. (The 1/3 octave analysis will be the most accurate.)
- 2 To obtain more detailed information about the vibration level, the evaluation according to ISO 5349 should be carried out. (The 1/3 octave analysis will give the most detailed information.)
- 3 The three different acceleration directions may be measured at different times.

3.2 Weight of accelerometers

The total mass of the accelerometer(s) giving the acceleration at one measuring position shall not exceed 50 g including the mounting but excluding the cables.

3.3 Mounting of accelerometers

If a resilient coating is being used between the hand and the vibrating structure (for example, a cushioned handle), it is permissible to use a suitable mount for the transducer (for example, a thin, suitably formed metal sheet) placed between the hand and the surface of the resilient material. In either case, care shall be taken that the size, shape and mounting of the transducer or of the special transducer support do not significantly influence the transfer of vibration to the hand. Care shall also be taken when mounting the transducer that the transfer function is flat up to 1 500 Hz for all three directions.

NOTES

- 1 The transfer function can be considered flat if an addition of mass to the accelerometer equal to that of the accelerometer and half that of the mount does not significantly influence $\bar{a}_{h,w}$. (This additional mass shall be placed between the accelerometer and the stud if it is of metal, or around the accelerometer if it is of clay or wax.)
- 2 The proposed method for the case of a resilient coating between the hand and the vibrating structure is not satisfactory for all conditions, particularly in the case of thin cushions mainly affecting the transfer of higher frequencies. In such cases it might be preferable to make the measurements with the transducer rigidly attached to the handle or structure and to report separately the type, thickness, physical properties and estimated attenuation achieved by the cushioning material.
- 3 For general considerations concerning accelerometer mounting see ISO 5348.

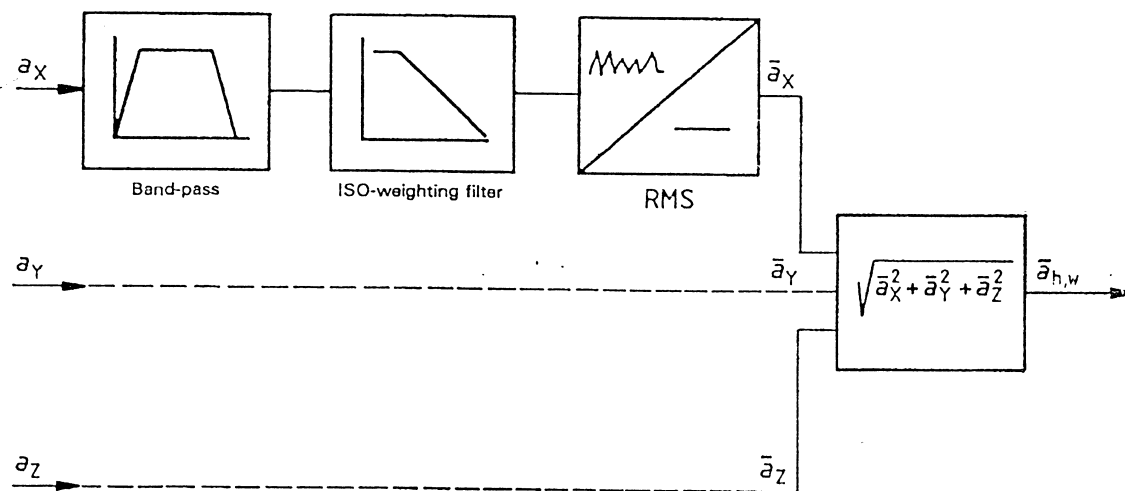

Figure 1 — Weighted acceleration sum ($\bar{a}_{h,w}$)

4 Positioning of accelerometers

The different directions of accelerometers and measuring positions are defined in figure 2. The centre of gravity of the accelerometers shall be positioned at a maximum distance of 20 mm from the contour described by taking a section through the handle defined by the lines Z and Y for the rear handle and the lines Z and X for the front handle. (See figure 2.)

If the measurement of 25 mm in figure 2 cannot be obtained, the accelerometer shall be placed at the right end of that portion of the handle intended to be grasped.

If the measurement of 80 mm in figure 2 cannot be obtained, the accelerometer shall be placed at the rear end of that portion of the handle intended to be grasped.

5 Accuracy of the measuring equipment

5.1 Measuring equipment

The accuracy of the measuring equipment excluding accelerometer mounting shall be within $\pm 10\%$ in the frequency range 8 to 1 500 Hz (see ISO 5347 concerning calibration).

Dimensions in millimetres

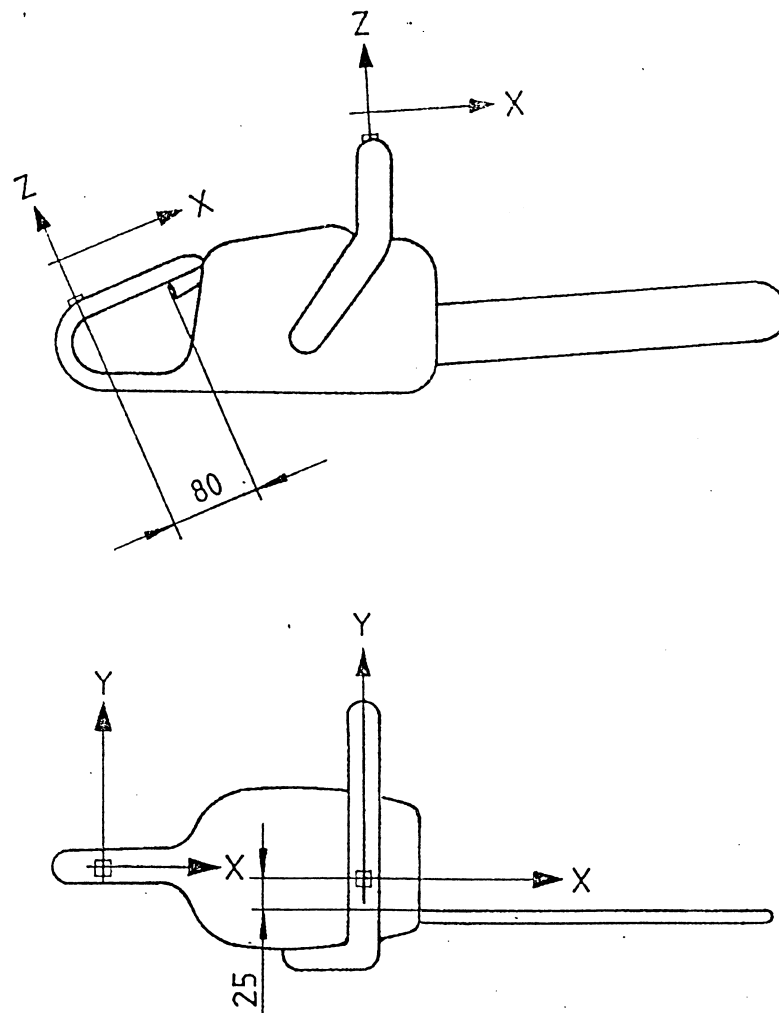

Figure 2 — Accelerometer positions

ISO 7505-1986 (E)

5.2 Electric noise

Special care shall be taken to avoid electric noise generated by the saw. (A suppressed spark-plug is recommended.) When the saw is running at the test place with the accelerometers free from contact with the saw but near to it (at a maximum distance of 20 mm from the measuring positions) the electric noise shall not exceed 5 % of the maximum measured value reported.

5.3 Rotational frequency indicator

The accuracy of the rotational frequency indicator shall be within $\pm 2,5$ % of the reading.

6 Rotational frequency range and measured value

6.1 Nominal rotational frequencies

The weighted acceleration sums ($\bar{a}_{h,w}$) at the front and the rear handles shall be measured at the following rotational frequencies:

- idling rotational frequency as recommended by the manufacturer (idling);
- rotational frequency at maximum engine power as stated by the manufacturer (full load);
- 133 % of the rotational frequency at maximum engine power or maximum rotational frequency, whichever is the less (racing).

6.2 Measuring interval

Each measured value shall be taken as the RMS-value over 2 s (equal to 1 s RC-detector time constant or time weighting characteristic S "slow" according to IEC 651). The rotational frequency shall be kept within $\pm 3,5$ s⁻¹ of the nominal rotational frequency during the registration.

6.3 Reported weighted acceleration sum ($\bar{a}_{h,w}$)

Each reported value of $\bar{a}_{h,w}$ shall be the RMS-value of at least five measured values according to 6.2.

7 Measuring object

Measurements shall be carried out on a normal production saw. The engine shall have been run in and warmed up before the test commences, carburettor set and ignition timed according to the instructions of the manufacturer. The chain shall be lubricated and the tanks shall be at least half-full. The chain shall be new and shall be adjusted for best cutting performance in accordance with the chain saw manufacturer's recommendation.

8 Hand-held method

8.1 Conditions

8.1.1 Measuring conditions

The measurements shall be carried out under the conditions described above.

8.1.2 Wood specification

For cutting tests a sound, well-grown log shall be taken from freshly-felled hardwood as in normal local usage. The log shall not be frozen. The cut shall be made in a part of the log free from knots.

8.1.3 Test log shape and guide bar length

The shape of the log should be as given in figure 3 and table 1.

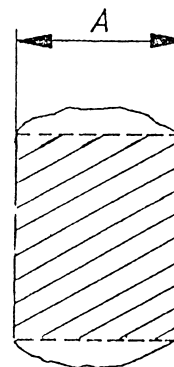

Figure 3 — Test log shape

The guide bar shall be that supplied by the manufacturer intended for normal use of the saw. If no guide bar is supplied a guide bar according to table 1 shall be chosen. The width of the log shall be correlated to the usable cutting length (see ISO 6531) of the guide bar in accordance with table 1.

Table 1 — Guide bar usable cutting length and width of test log

Engine displacement cm ³	Usable cutting length of the guide bar, <i>L</i> m	Width of log, <i>A</i> m
0 to 44	0,25 to 0,35	(75 ± 5) % of <i>L</i>
45 to 69	0,30 to 0,40	(75 ± 5) % of <i>L</i>
70 to 89	0,40 to 0,50	(75 ± 5) % of <i>L</i>
90 and above	> 0,50	<i>L</i> - 0,1

8.2 Operations

8.2.1 General conditions

The chain saw shall be operated upright in accordance with figure 4.

The log shall be horizontal and rigidly mounted on a stiff support, so that its centreline is about 0,6 m above the ground level.

A relaxed grip on the handles sufficient to maintain proper control shall be employed, consistent with day-long use of the saw.

8.2.2 Operation sequence

The operation sequence shall be

- idling,
- cutting (full load),
- racing,

at the rotational frequencies defined in 6.1.

This sequence shall be repeated five times.

8.2.3 Operating conditions

8.2.3.1 Idling

At idling, the saw shall be held with both hands in a position normally used between two cuts. The saw chain shall not move.

8.2.3.2 Cutting

At cutting (full load), slices shall be cut from the log with the throttle fully open. During the cut, the guide bar shall be kept in a horizontal position and perpendicular to the axis of the log.

The rotational frequency indicator shall be located in such a way that the operator can read the engine rotational frequency without extra disturbance of his work.

The measurements shall be taken in the middle third of the log. The rotational frequency of the engine shall be controlled by the cutting force. Any contact between the machine and the log shall be avoided. If necessary and possible, the spiked bumper should be removed.

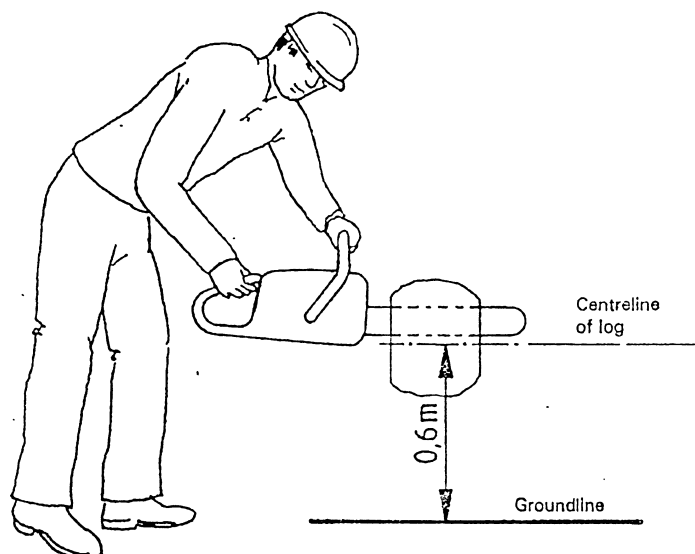

Figure 4 — Chain saw position at cutting

ISO 7505-1986 (E)

8.2.3.3 Racing

At racing, the saw shall be held with both hands in a position normally used between two cuts. The rotational frequency shall be controlled by operation of the throttle if the maximum possible rotational frequency exceeds 133 % of the maximum power rotational frequency.

9 Test report

The test report shall include the following information:

- a) reference to this International Standard;
- b) date and place of measurement;
- c) observer and operator;
- d) description of the saw:
 - 1) manufacturer;
 - 2) model (type);
 - 3) serial No.;
 - 4) guide bar (type and effective length);
 - 5) sprockets (number of teeth);
 - 6) chain (type and pitch);
- e) measuring equipment;
- f) height and weight of the operator (for hand-held operation);
- g) description of the accelerometer mounting;
- h) procedure to obtain $\bar{a}_{h,w}$;
- i) type of wood;
- j) initiator of test;
- k) reference to the test method (hand-held or test rig);
- l) table with test data according to table 2.

Table 2 — Presentation of test data

Operation condition	Rotational frequency	Weighted acceleration, $\bar{a}_{h,w}$ m/s ²									
		Front handle					Rear handle				
		Test				$\bar{a}_{h,w}$	Test				$\bar{a}_{h,w}$
1	2	3	4	5	1		2	3	4	5	
Idling											
Full load											
Racing											

Annex

Frequency range and weighting filter

(This annex forms an integral part of the Standard.)

The frequency weighting filter used when forming $\bar{a}_{h,w}$ (see 3.1) is defined in table 3. The filter characteristics are shown in figure 5. (The weighting filter includes the band-pass filtration shown in figure 1.)

Table 3 — Frequency weighting filter for hand-arm (see figure 5)

Frequency, f Hz	Nominal value dB	Tolerances dB	
< 3,15	slope of -12 dB/oct	+3	$-\infty$
3,15	-12	+3	$-\infty$
5,0	-4	+3	-4
6,3	0	+1	-4
8,0	0		± 1
10,0	0		± 1
12,5	0		± 1
16	0		± 1
20	-2		± 1
$20 < f < 800$	slope of -6 dB/oct		± 1
800	-34		± 1
1 000	-38	+1	-3
1 250	-38	+1	-5
1 600	-45	+2	$-\infty$
> 1 600	slope of -12 dB/oct	+2	$-\infty$

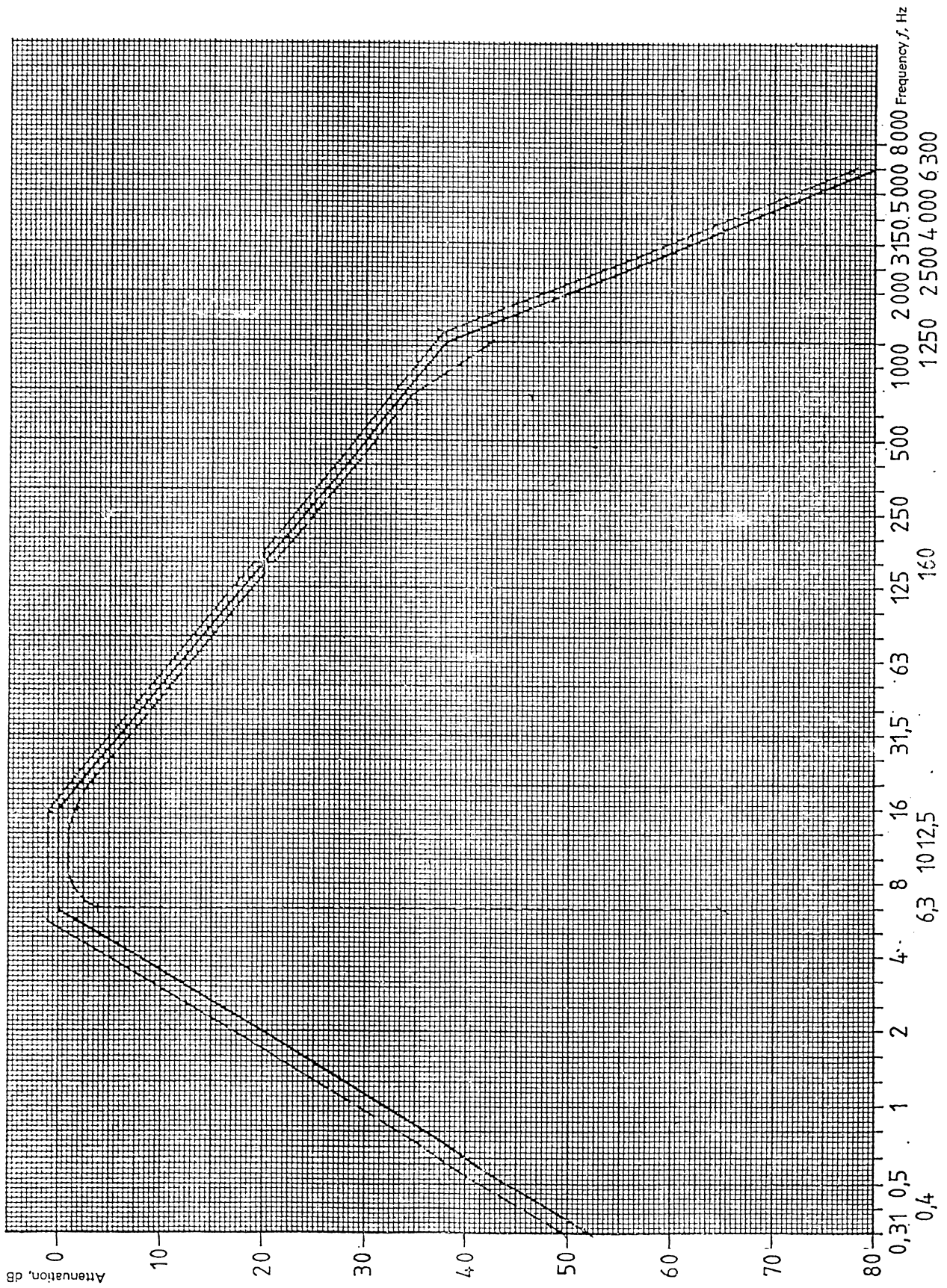

Figure 5 — Frequency weighting filter for triand-arm