

INTERNATIONAL STANDARD

ISO 7493

Third edition
2006-05-01

Dentistry — Operator's stool

Art dentaire — Siège d'opérateur



Reference number
ISO 7493:2006(E)

© ISO 2006

PDF disclaimer

This PDF file may contain embedded typefaces. In accordance with Adobe's licensing policy, this file may be printed or viewed but shall not be edited unless the typefaces which are embedded are licensed to and installed on the computer performing the editing. In downloading this file, parties accept therein the responsibility of not infringing Adobe's licensing policy. The ISO Central Secretariat accepts no liability in this area.

Adobe is a trademark of Adobe Systems Incorporated.

Details of the software products used to create this PDF file can be found in the General Info relative to the file; the PDF-creation parameters were optimized for printing. Every care has been taken to ensure that the file is suitable for use by ISO member bodies. In the unlikely event that a problem relating to it is found, please inform the Central Secretariat at the address given below.

© ISO 2006

All rights reserved. Unless otherwise specified, no part of this publication may be reproduced or utilized in any form or by any means, electronic or mechanical, including photocopying and microfilm, without permission in writing from either ISO at the address below or ISO's member body in the country of the requester.

ISO copyright office
Case postale 56 • CH-1211 Geneva 20
Tel. + 41 22 749 01 11
Fax + 41 22 749 09 47
E-mail copyright@iso.org
Web www.iso.org

Published in Switzerland

Foreword

ISO (the International Organization for Standardization) is a worldwide federation of national standards bodies (ISO member bodies). The work of preparing International Standards is normally carried out through ISO technical committees. Each member body interested in a subject for which a technical committee has been established has the right to be represented on that committee. International organizations, governmental and non-governmental, in liaison with ISO, also take part in the work. ISO collaborates closely with the International Electrotechnical Commission (IEC) on all matters of electrotechnical standardization.

International Standards are drafted in accordance with the rules given in the ISO/IEC Directives, Part 2.

The main task of technical committees is to prepare International Standards. Draft International Standards adopted by the technical committees are circulated to the member bodies for voting. Publication as an International Standard requires approval by at least 75 % of the member bodies casting a vote.

Attention is drawn to the possibility that some of the elements of this document may be the subject of patent rights. ISO shall not be held responsible for identifying any or all such patent rights.

ISO 7493 was prepared by Technical Committee ISO/TC 106, *Dentistry*, Subcommittee SC 6, *Dental equipment*.

This third edition cancels and replaces the second edition (ISO 7493:1997) and its Technical Corrigendum 1:1999, which have been technically revised. The following changes were made:

- a) The requirements for seat height and range of adjustment (see 4.2 in this edition) have been changed to reflect ISO 7493:1997 Technical Corrigendum 1.
- b) A requirement for sampling has been added (Clause 5).
- c) The test procedure for the stability of the stool has been revised (see 6.5). Figure 1 has been revised to reflect this change.
- d) The test procedure for cleaning and disinfection has been revised (see 6.8).
- e) References to ISO 6385 and ISO 11226 have been added to Annex A.

Introduction

The objectives of this International Standard are to ensure that the design and functioning of the operator's stool in the dental office will be such as to enable the dental operator to perform his or her work effectively and safely, to minimize the muscular and skeletal stresses, particularly in shoulders and spine, that arise during the performance of the work, and to allow freedom of movement without undue muscular activity.

Dentistry — Operator's stool

1 Scope

This International Standard specifies requirements, recommendations and test methods for the operator's stool in the dental office as well as requirements for the manufacturer's instructions for use and for marking and packaging. It also covers recommendations to manufacturers on the design of operator's stools.

For purposes of this International Standard, the term "dental operator" includes dentists, dental assistants and dental hygienists.

2 Normative references

The following referenced documents are indispensable for the application of this document. For dated references, only the edition cited applies. For undated references, the latest edition of the referenced document (including any amendments) applies.

ISO 1942 ¹⁾, *Dentistry — Vocabulary*

ISO 8191-1, *Furniture — Assessment of the ignitability of upholstered furniture — Part 1: Ignition source: smouldering cigarette*

ISO 9687, *Dental equipment — Graphical symbols*

ISO 21530, *Dentistry — Materials used for dental equipment surfaces — Determination of resistance to chemical disinfectants*

3 Terms and definitions

3.1 Terms and definitions

For the purposes of this document, the terms and definitions given in ISO 1942 and the following apply.

3.1.1

operator's stool

movable seat, adjustable in height, which satisfies the general requirements relevant to the performance of dentistry by a seated operator

3.1.2

anterio-posterior plane

vertical plane which divides the operator's stool into left and right halves

3.1.3

seat height

vertical distance between the floor and the point of intersection of the swivel axis with the plane of the loaded surface or the unloaded surface of the seat

1) To be published. [Revision of ISO 1942 (all parts):1989.]

3.1.4

seat width

horizontal dimension of the widest part of the seat between the upper edges of the sides of the seat, measured perpendicularly to the anteroposterior plane of the seat

3.1.5

seat depth

horizontal dimension measured alongside the centre of the seat width in the anteroposterior plane of the seat between the vertical projections of the front edge and the back edge of the seat

NOTE If the stool is provided with a backrest, the dimension is measured between the foremost projection of the centreline of the backrest and the normal projection of the front edge of the seat.

3.1.6

backrest height

vertical distance between reference Point A and reference Point B, measured with the seat loaded and with an unloaded backrest (in free-standing position)

For this measurement, it is necessary to adjust the backrest to its most forward position and, if it can be pivoted upon a horizontal axis, to put it in the vertical position.

3.1.7

least favourable position of the operator's stool

position of the operator's stool at which the load-bearing part of the seat and two adjacent castors are placed in their least favourable position with regard to the seat-tipping stability

3.2 Symbols

Figure 1 shows the following symbols:

- h_1 seat height for loaded surface;
- h_2 seat height for unloaded surface;
- h_3 backrest height;
- c_1 seat depth;
- c_2 seat depth, if a backrest is provided;
- c_3 seat width;
- e horizontal distance between the line connecting the swivel axis and the axis of two adjacent castors in their least favourable position;
- A reference Point A, the point of intersection of the plane of the upper-loaded surface of the seat with the vertical axis of the stool;
- B reference Point B, the centre of the area on the backrest that provides lumbar support and point of application of the force for testing the deflection of the backrest;
- C reference Point C, the point on the vertical axis where the vertical force for testing the load-carrying capacity of the stool is applied;
- D reference Point D, the point on the upper plane of the unloaded seat at a distance of 60 mm from the least favourable edge of the seat where the vertical and horizontal forces for testing the stability of the stool are applied (the magnitude and direction of the forces to be applied in the stability test are depicted for clarity);
- E reference Point E, the point for the application of vertical force for testing the armrest;
- F reference Point F, the point for the application of horizontal force for testing the armrest;
- G reference Point G, the point for the application of horizontal force for testing the armrest.

Dimensions in millimetres

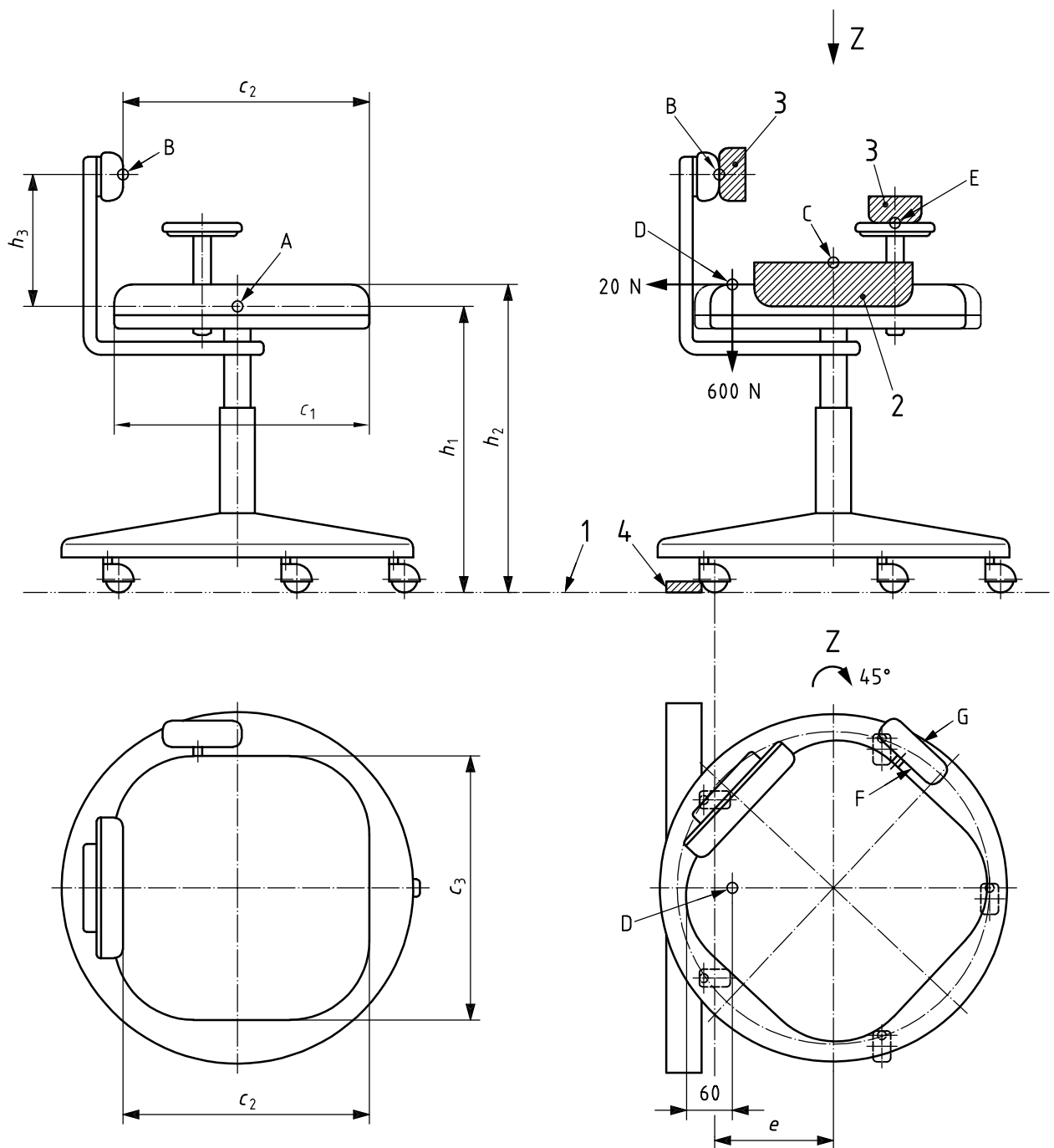

Key

- 1 floor
- 2 test pad 1
- 3 test pad 2
- 4 stop

NOTE 1 This figure is not intended to specify the design of the operator's stool. The armrest depiction represents either an armrest or the torso support, if provided.

NOTE 2 The lower right drawing projection is rotated around axis Z by 45°.

Figure 1 — Designation of dimensions and reference points for the operator's stool

4 Requirements

4.1 General

- 4.1.1 Compliance with the following requirements shall be checked by visual inspection.
- 4.1.2 The seat of the operator's stool shall be adjustable in height and shall swivel freely around the vertical axis.
- 4.1.3 The upper part of the operator's stool shall not be removable from the base without the use of a tool.
- 4.1.4 The operator's stool should be provided with a backrest which can be adjusted horizontally and vertically independent of the seat height.
- 4.1.5 The operator's stool should be provided with five castors arranged pentagonally on the base of the stool.

4.2 Seat height and range of adjustment

The minimum adjustable height of the loaded seat and the range of adjustment of the seat height shall be given by the manufacturer with the instructions for use.

4.3 Load-carrying capacity of operator's stool

The operator's stool shall not have a change in height exceeding 10 mm when tested in accordance with 6.4.

4.4 Stability of operator's stool

The operator's stool shall not tip during testing.

Testing shall be carried out in accordance with 6.5.

4.5 Deflection of the backrest

The backrest, if provided, shall not show a horizontal deflection at reference Point B that exceeds 30 mm, when tested in accordance with 6.6.

4.6 Armrest and torso support

The armrests or torso support, if provided, shall be capable of withstanding without failure or permanent deformation when tested in accordance with 6.7.

4.7 Cleaning and disinfection

All exterior parts of the operator's stool shall be capable of being cleaned and disinfected, using agents recommended by the stool manufacturer, without deteriorating the stool's surface and markings.

Testing shall be carried out in accordance with 6.8.

4.8 Flammability

The upholstery and padding of the operator's stool shall not catch fire and resultant charring, if any, shall not be greater in length than 30 mm in any direction measured from the nearest point of the test cigarette.

Testing shall be carried out in accordance with 6.9.

5 Sampling

Use one representative sample of the operator's stool.

6 Test procedures

6.1 General

All tests described in this International Standard are type tests.

6.2 Visual inspection

Visual inspection shall be performed at normal visual acuity without magnification.

6.3 Apparatus

For the tests the following apparatus shall be used.

6.3.1 Operator's stool.

6.3.2 Test pad 1, having a 350 mm diameter and a radius of 15 mm at the edge (see Figure 1).

6.3.3 Test pad 2, having a 100 mm diameter and a radius of 15 mm at the edge (see Figure 1).

6.4 Load-carrying capacity of stool

Adjust the seat height to its maximum value.

Select and mark a suitable point on the seat, and arrange means for determining its vertical distance from some other suitable point marked on the floor.

Apply and maintain a downward vertical force of 1 350 N to the centre of the seat (reference Point C in Figure 1) using Test pad 1.

After 5 min, determine and record the value of the vertical distance, in millimetres (Reading 1).

After 60 min, redetermine and record the value of the vertical distance, in millimetres (Reading 2).

Report the change in value, in millimetres (Reading 1 minus Reading 2).

6.5 Stability of the stool

With the stool on a horizontal surface and the seat at its maximum height and swivelled in its least favourable position relative to the castors, position the two adjacent castors against stops to prevent the stool from sliding or rolling but not tilting.

Apply a downward vertical force of 600 N using Test pad 2 acting 60 mm inward from the edge of the load bearing structure at those points most likely to result in overbalancing (reference Point D as shown in Figure 1). Apply a horizontal load of 20 N outwards at the point where the base of the test pad meets the upper surface of the seat (reference Point D as shown in Figure 1) for at least 5 s.

Report whether the operator's stool tips.

6.6 Deflection of the backrest

Adjust the backrest height to its highest position.

Fix the operator's stool rigidly to the floor.

Mark the reference Point B (see Figure 1) on the backrest, and determine its horizontal distance, in millimetres, from some other clearly marked point (for example on the floor). If the backrest is springloaded, determine this horizontal distance after full compression of the springs.

Apply a horizontal force of 250 N at reference Point B using Test pad 2.

Redetermine the horizontal distance, in millimetres, of reference Point B from the marked point.

Calculate the deflection, in millimetres, as the difference between the two values obtained.

6.7 Armrest and torso support

Apply a downward vertical force of 335 N at the point along the armrest or torso support most likely to cause failure (reference Point E in Figure 1) for 1 min using Test pad 2, and subsequently a horizontal force of 220 N at the points along the armrest or torso support most likely to cause failure for the outward and inward directions respectively (reference Points F and G in Figure 1).

6.8 Cleaning and disinfection

Testing shall be carried out in accordance with ISO 21530 using agents recommended by the manufacturer.

6.9 Flammability

Testing shall be carried out in accordance with ISO 8191-1.

7 Manufacturer's instructions for use

The manufacturer shall supply instructions for the safe operation and use of the operator's stool. The instructions shall include step-by-step procedures for operating and maintaining the stool, with illustrations showing the location of the controls, together with explanations of their use.

The instructions for use shall also include the following information:

- a) lowest seat height;
- b) highest seat height;
- c) range of adjustment of seat height;
- d) seat depth;
- e) seat width;
- f) range of backrest adjustment;
- g) recommendations for cleaning and disinfecting agents, together with instructions for their use.

8 Marking of the operator's stool

The operator's stool shall be marked with at least the following information:

- a) manufacturer's name or trademark;
- b) model;
- c) serial number.

Symbols used for marking shall be in accordance with ISO 9687.

9 Packaging of the operator's stool

The operator's stool shall be packaged for transportation in such a way that no damage can occur during anticipated transport conditions.

If several packages are supplied, they shall be marked on the outside to facilitate assembly and installation of the stool.

www.iso.org

Annex A (informative)

Recommendations to manufacturers on design of operator's stool

- A.1** The ergonomic principles specified in ISO 6385 and ISO 11226 should be incorporated into the design of the stool.
- A.2** The design of the stool and backrest should facilitate the dental operator to comfortably adopt all the body positions usually assumed when performing dental treatment.
- A.3** The front edge of the seat should be of such a shape as to minimize pressure under the thighs.
- A.4** The upholstery should be resistant to water and conducive to the comfort of a dental operator seated for extended periods, and over periods in which temperature and humidity may change.
- A.5** The lateral adjustment of the backrest should enable the dental operator, when in correct working posture, to be supported by a backrest.
- A.6** The stool, unless otherwise specified, shall be easily movable in the unloaded or loaded condition.
- A.7** The abrasion resistance of the material used for the castors which contact the floor should be high enough to prevent floor coverings from being marked.
- A.8** The dimensions of the castors should be such as to minimize contact loads (and hence minimize scoring and indentation of floor coverings) and, unless otherwise specified, permit unconstrained movement of the loaded or unloaded stool in any direction.
- A.9** If a counterbalancing force is provided in the seat height-adjustment mechanism, it shall ensure adequate support throughout the range of adjustment.
- A.10** The design of projecting parts should be avoided, and mechanical parts should be protected in order to minimize the risk of injury to the patient and dental personnel as well as damage to adjacent items of dental equipment.
- A.11** Controls, if provided for the adjustment of the seat and backrest, should be arranged and located so as to render their accidental actuation unlikely.
- A.12** Moving parts that may constitute a hazard under normal working conditions should be protected or guarded to minimize the risk of injury to the dental operator or other personnel.

Bibliography

- [1] ISO 6385, *Ergonomic principles in the design of work systems*
- [2] ISO 11226, *Ergonomics — Evaluation of static working postures*

.....

ICS 11.060.20

Price based on 9 pages