

# INTERNATIONAL STANDARD

# ISO 7481

Second edition  
2000-02-01

---

---

## **Aerospace — Nuts, self-locking, with maximum operating temperature less than or equal to 425 °C — Test methods**

*Aéronautique et espace — Écrous à freinage interne dont la température maximale d'utilisation est inférieure ou égale à 425 °C — Méthodes de contrôle et d'essai*



Reference number  
ISO 7481:2000(E)

© ISO 2000

**PDF disclaimer**

*This PDF file may contain embedded typefaces. In accordance with Adobe's licensing policy, this file may be printed or viewed but shall not be edited unless the typefaces which are embedded are licensed to and installed on the computer performing the editing. In downloading this file, parties accept therein the responsibility of not infringing Adobe's licensing policy. The ISO Central Secretariat accepts no liability in this area.*

Adobe is a trademark of Adobe Systems Incorporated.

Details of the software products used to create this PDF file can be found in the General Info relative to the file; the PDF-creation parameters were optimized for printing. Every care has been taken to ensure that the file is suitable for use by ISO member bodies. In the unlikely event that a problem relating to it is found, please inform the Central Secretariat at the address given below.

© ISO 2000

All rights reserved. Unless otherwise specified, no part of this publication may be reproduced or utilized in any form or by any means, electronic or mechanical, including photocopying and microfilm, without permission in writing from either ISO at the address below or ISO's member body in the country of the requester.

ISO copyright office  
Case postale 56 • CH-1211 Geneva 20  
Tel. + 41 22 749 01 11  
Fax + 41 22 734 10 79  
E-mail [copyright@iso.ch](mailto:copyright@iso.ch)  
Web [www.iso.ch](http://www.iso.ch)

Printed in Switzerland

# Contents

Page

Foreword.....	iv
<b>1 Scope .....</b>	<b>1</b>
<b>2 Normative references .....</b>	<b>1</b>
<b>3 Inspections and tests .....</b>	<b>2</b>
<b>3.1 Hardness test .....</b>	<b>2</b>
<b>3.2 Bearing surface squareness test .....</b>	<b>2</b>
<b>3.3 Axial load test.....</b>	<b>4</b>
<b>3.4 Wrenching feature test.....</b>	<b>6</b>
<b>3.5 Stress embrittlement test.....</b>	<b>7</b>
<b>3.6 Torque-out test .....</b>	<b>8</b>
<b>3.7 Test of no rotation of the captive washer .....</b>	<b>9</b>
<b>3.8 Push-out test.....</b>	<b>10</b>
<b>3.9 Self-locking torque at ambient temperature .....</b>	<b>12</b>
<b>3.10 Self-locking torque at ambient temperature after heat soak at maximum operating temperature .....</b>	<b>14</b>
<b>3.11 Permanent set test.....</b>	<b>15</b>
<b>3.12 Vibration test.....</b>	<b>16</b>

## Foreword

ISO (the International Organization for Standardization) is a worldwide federation of national standards bodies (ISO member bodies). The work of preparing International Standards is normally carried out through ISO technical committees. Each member body interested in a subject for which a technical committee has been established has the right to be represented on that committee. International organizations, governmental and non-governmental, in liaison with ISO, also take part in the work. ISO collaborates closely with the International Electrotechnical Commission (IEC) on all matters of electrotechnical standardization.

International Standards are drafted in accordance with the rules given in the ISO/IEC Directives, Part 3.

Draft International Standards adopted by the technical committees are circulated to the member bodies for voting. Publication as an International Standard requires approval by at least 75 % of the member bodies casting a vote.

Attention is drawn to the possibility that some of the elements of this International Standard may be the subject of patent rights. ISO shall not be held responsible for identifying any or all such patent rights.

International Standard ISO 7481 was prepared by Technical Committee ISO/TC 20, *Aircraft and space vehicles*, Subcommittee SC 4, *Aerospace fastener systems*.

This second edition cancels and replaces the first edition (ISO 7481:1984), which has been technically revised. Notably, a test for no rotation of the captive washer was added.

# Aerospace — Nuts, self-locking, with maximum operating temperature less than or equal to 425 °C — Test methods

## 1 Scope

This International Standard specifies test methods for metric self-locking nuts with MJ threads intended for use in aerospace construction at maximum operating temperatures less than or equal to 425 °C. It describes the test device and the method for each test.

It applies to self-locking nuts as defined above, provided that the relevant documents (dimensional standard, drawing, procurement specification, etc.) refer to this International Standard.

This International Standard shall be used in conjunction with ISO 5858.

**NOTE** This International Standard only specifies tests for ambient and elevated temperature applications. Tests for applications at less than ambient temperatures, for example cryogenic, shall be as agreed upon between seller and purchaser.

## 2 Normative references

The following normative documents contain provisions which, through reference in this text, constitute provisions of this International Standard. For dated references, subsequent amendments to, or revisions of, any of these publications do not apply. However, parties to agreements based on this International Standard are encouraged to investigate the possibility of applying the most recent editions of the normative documents indicated below. For undated references, the latest edition of the normative document referred to applies. Members of ISO and IEC maintain registers of currently valid International Standards.

ISO 691:1997, *Assembly tools for screws and nuts — Wrench and socket openings — Tolerances for general use.*

ISO 1024:1989, *Metallic materials — Hardness test — Rockwell superficial test (scales 15N, 30N, 45N, 15T, 30T and 45T).*

ISO 5855-2:1999, *Aerospace — MJ threads — Part 2: Limit dimensions for bolts and nuts.*

ISO 5858:1999, *Aerospace — Nuts, self-locking, with maximum operating temperature less than or equal to 425 °C — Procurement specification.*

ISO 6507-1:1997, *Metallic materials — Vickers hardness test — Part 1: Test method.*

ISO 6508-1:1999, *Metallic materials — Rockwell hardness test — Part 1: Test method (scales A, B, C, D, E, F, G, H, K, N, T).*

ISO 7403:1998, *Aerospace — Spline drives — Wrenching configuration — Metric series.*

## ISO 7481:2000(E)

### 3 Inspections and tests

#### 3.1 Hardness test

##### 3.1.1 Procedure

The choice depends on the configuration of the nut and available equipment. The authorized procedures are:

- Rockwell hardness in accordance with ISO 6508-1;
- Vickers hardness HV 5 to HV 100 in accordance with ISO 6507-1;
- Rockwell superficial hardness in accordance with ISO 1024;
- microhardness.

##### 3.1.2 Method

This test shall be carried out at ambient temperature.

The measurement zone (bearing surface, across flats, underside of anchor nut lugs, etc.) shall correspond to the following conditions:

- a) thickness at least equal to 10 times the penetration depth;
- b) parallelism with respect to bearing surface not greater than 3°.

Should this not be possible, carry out this test on a cut section after moulding the nut into thermosetting resin.

Remove all possible coating (protection, lubrication, paint, etc.) in the measurement zone. Align the bearing surface to obtain the required relationship. These two operations shall not generate any heat liable to modify the characteristics of the material constituting the nut being tested.

Carry out the test and then check conformity with the requirements of the dimensional standard or drawing.

Nuts subjected to this test shall not be used again.

#### 3.2 Bearing surface squareness test

##### 3.2.1 Test device

The test device is illustrated in Figure 1.

The test device includes the following elements:

- a) a threaded mandrel with end in accordance with ISO 5855-2, with the exception of the pitch diameter which shall be in accordance with the values specified in Table 5 for the maximum mandrel;
- b) a collar sliding on the plain portion of the threaded mandrel whose external diameter  $B$  is at least equal to reference dimension  $A$  for type I, II and V nuts in Figure 2 and equal to reference dimension  $A$  for type III and IV nuts in Figure 2;
- c) an appropriate feeler gauge.

Dimensions in millimetres

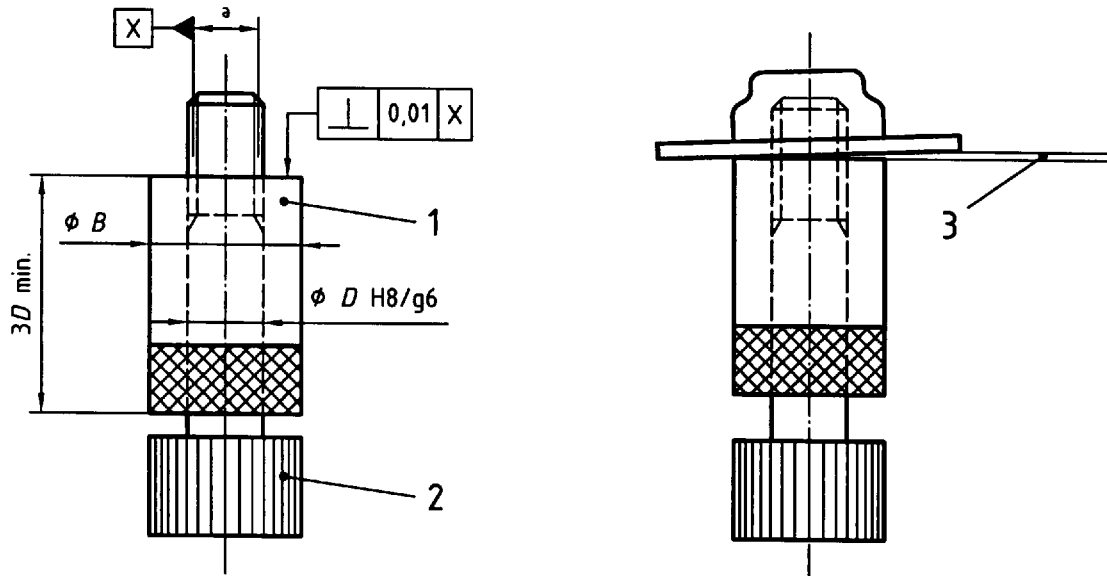

**Key**

- 1 Sliding collar
- 2 Threaded mandrel
- 3 Feeler gauge

NOTE For clinch nuts, the sliding collar shall have a counterbore to accommodate the shank.

a Pitch diameter

**Figure 1**

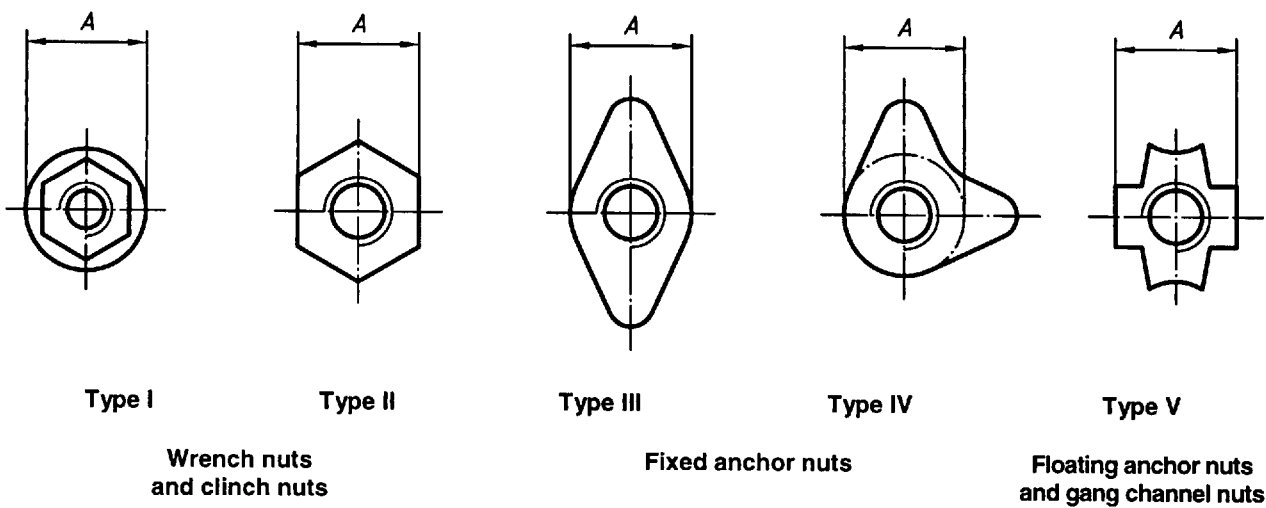

**Figure 2**

**ISO 7481:2000(E)****3.2.2 Method**

The test shall be carried out at ambient temperature.

For floating nuts, extract the nut from the cage or channel.

Lubricate the mandrel and nut (or threaded part) threads as stated in Table 1 (if necessary). Screw, with or without a wrench, the threaded mandrel into the nut or threaded part up to a minimum engagement of three turns.

Move the collar into contact with the bearing surface.

Evaluate the out-of-squareness by means of a feeler gauge whose thickness corresponds to the permissible squareness error permitted by the dimensional standard, the drawing or the procurement specification.

**3.3 Axial load test****3.3.1 Test device**

The test device is illustrated in Figure 3.

The test device includes the following elements:

- a) a bearing plate in steel, heat-treated to a hardness  $\geq 40$  HRC;
- b) a conical washer (for testing countersunk nuts);
- c) a bolt with characteristics as follows:
  - 1) threads: in accordance with ISO 5855-2,
  - 2) tensile strength class: greater than that of the nut under test,
  - 3) material and coating: no specific requirement.

**3.3.2 Method**

The axial load is transmitted to the nut by the bolt, the nut resting on the bearing plate.

For countersunk nuts, a conical washer is interposed.

**3.3.2.1 80 % test**

This test shall be carried out at ambient temperature.

Lubricate the bolt and nut threads as stated in Table 1 (if necessary). Assemble the bearing plate, and possibly the conical washer, onto the bolt. Assemble the nut and measure the locking torque when the protrusion is two pitches minimum (including chamfer).

Position the assembly on the tensile machine. Apply the load slowly and progressively. Reduce the load slowly and progressively when the value quoted in the procurement specification has been reached.

Remove the assembly from the tensile machine. Unscrew the nut a half-turn and cease movement, then again unscrew and measure the breakaway torque.

Remove the nut, then submit it to a visual examination, and if necessary, an examination at a magnification of  $\times 10$  after sectioning, to check conformity with the requirements of the procurement specification.



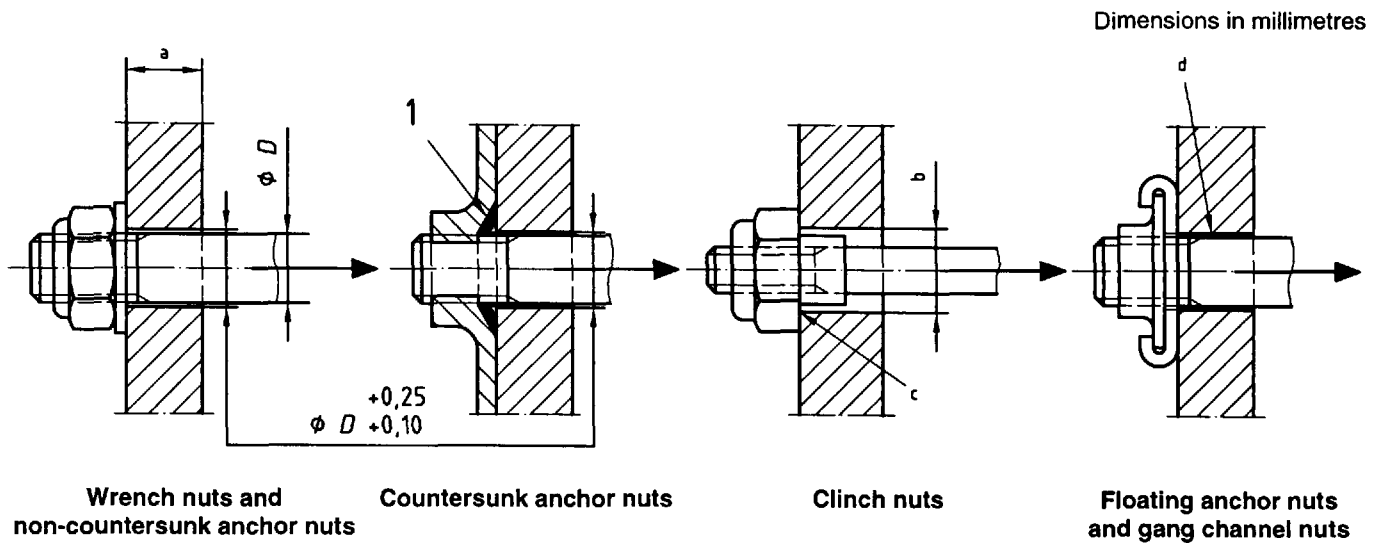

**Key**

- 1 Washer to fit countersink
- a Thickness  $\geq D$
- b Maximum shank diameter  $\begin{matrix} +0,25 \\ +0,10 \end{matrix}$
- c Chamfer to suit the nut radius
- d The hole shall allow the specified float.

**Figure 3**

**Table 1 — Test bolt and lubrication**

Nut to be tested			Test bolt		Additional lubrication
Locking	Material	Coating	Material	Coating	
Plastic insert	Any	Any	Alloy steel	Cadmium	None
Metallic	Steel or alloy steel	Any	Alloy steel	Cadmium	None
	Stainless steel	Silver or MoS <sub>2</sub>	Stainless steel	None	Synthetic oil
		None	Stainless steel	Silver	

**3.3.2.2 100 % test**

This test shall be carried out at ambient temperature.

If the test includes a heat soak, then heat the nut and maintain it at the temperature quoted in the procurement specification. Take the nut from the oven and allow it to cool slowly to ambient temperature, then proceed as follows.

Lubricate the bolt and nut threads as specified in Table 1 (if necessary), assemble the bearing plate and, if required, the conical washer, onto the bolt. Assemble the nut with a protrusion of two bolt pitches minimum (including chamfer).

Position the assembly on the tensile machine and apply the load slowly and progressively. Reduce the load slowly and progressively when the value quoted in the procurement specification has been reached.

ISO 7481:2000(E)

Remove the assembly from the tensile machine. Remove the nut, then submit it to a visual examination, and if necessary, an examination at a magnification of  $\times 10$  after sectioning to check conformity with the requirements of the procurement specification.

Nuts subjected to this test shall not be used again.

**3.4 Wrenching feature test**

This test applies only to wrenchable nuts.

**3.4.1 Test device**

The test device is illustrated in Figure 4.

The test device includes the following elements:

- a) a block of steel, heat-treated to a hardness of  $\geq 40$  HRC;
- b) a bolt with characteristics as follows:
  - 1) threads: in accordance with ISO 5855-2,
  - 2) tensile strength class: no specific requirement,
  - 3) material and coating: no specific requirement.

**NOTE** Any other device which prevents the rotation of the nut and allows the specified torque to be applied is acceptable. For instance:

- nut welded on a block of the same material, the assembly being heat-treated to the correct level;
- nuts mounted in counter-rotation on a threaded rod of strength class appropriate to hold the required torques without deformation;
- nut mounted on a bolt of strength class appropriate to hold the required torques without deformation as a spacer is placed between the nut and the bolt head;
- etc.

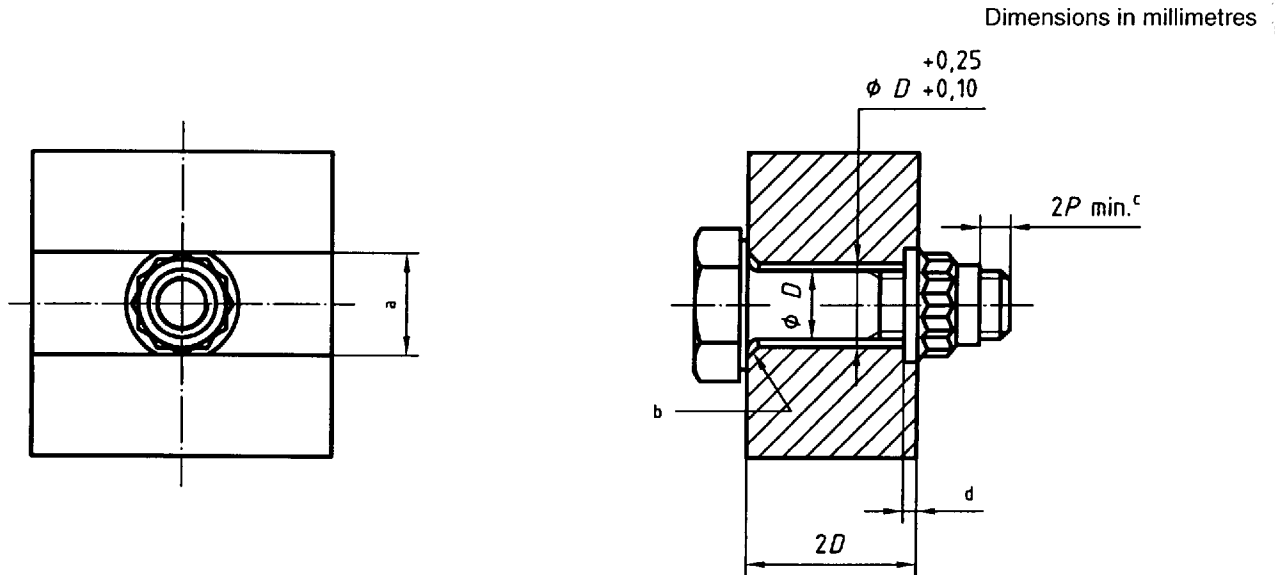

- a Width of slot equal to diameter of circle circumscribing the wrenching feature
- b Chamfer to suit underhead radius
- c Including chamfer, where  $P$  is the pitch
- d Depth of slot equal to flange height of nut under test

**Figure 4**

### 3.4.2 Method

This test shall be carried out at ambient temperature.

Make two flats on the flange of the nut so that it has a clearance of 0,05 mm to 0,1 mm inside the slot, lubricate the bolt and nut threads as specified in Table 1 (if necessary). Insert the modified nut into the slot. Assemble the bolt and moderately tighten it, then assemble the block into a vice.

Repeat the following operations the number of times specified in the procurement specification:

Apply the torque to the nut, in a tightening movement, as quoted in the procurement specification, with the aid of a socket wrench with an opening tolerance in conformance with ISO 691 or ISO 7403. Remove, then replace the socket wrench. Apply the same torque to the nut in an untightening direction.

Finally, dismantle the assembly, then submit the nut to a visual examination and, if necessary, to an examination at a magnification of  $\times 10$  after sectioning to check conformity with the requirements of the procurement specification.

Nuts subjected to this test shall not be used again.

### 3.5 Stress embrittlement test

This test applies only to nuts heat-treated to a hardness  $\geq 44$  HRC except for opposite indication given in the procurement specification or definition document.

#### 3.5.1 Test device

The test device is illustrated in Figure 5.

The test device includes the following elements:

- a) a block with parallel faces in steel, heat-treated to a hardness  $\geq 40$  HRC;
- b) a bolt with the following characteristics:
  - 1) thread: in accordance with ISO 5855-2,
  - 2) tensile strength requirement greater than that of the nut under test,
  - 3) material and coating: no specific requirement.

#### 3.5.2 Method

This test shall be carried out at ambient temperature.

Hold the bolt by the head, lubricate the bolt and nut threads as specified in Table 1 (if necessary), assemble the block and assemble the nut to be tested.

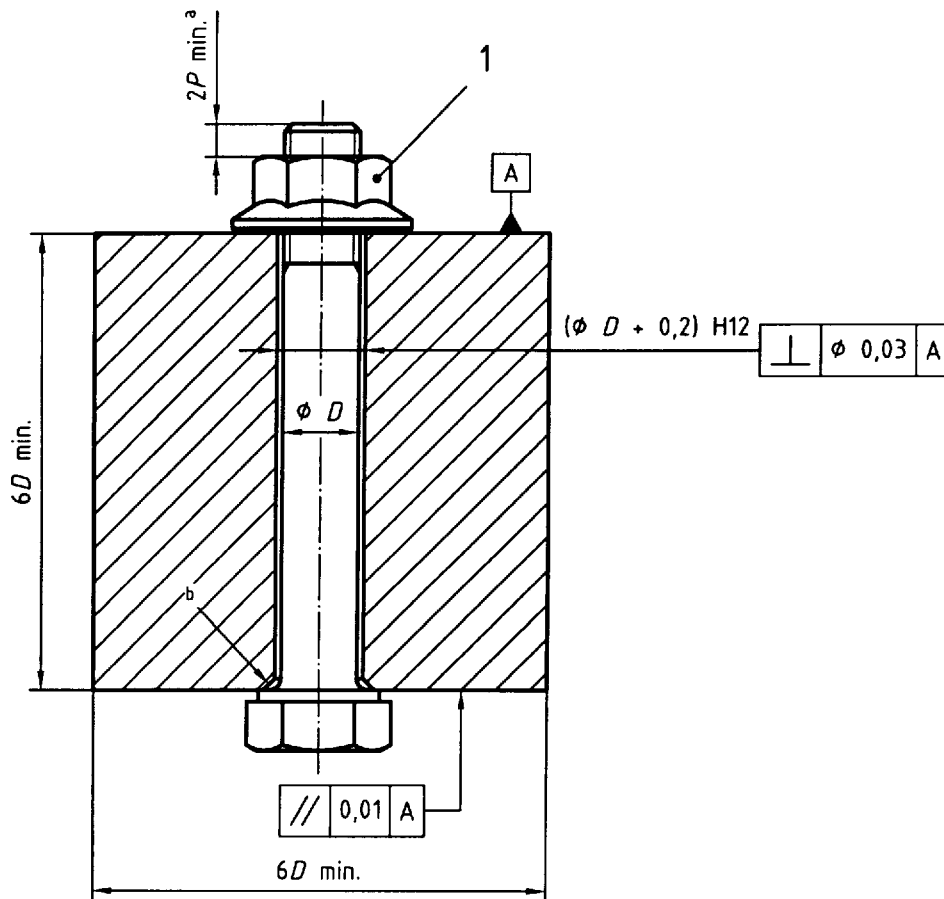

**Key**

- 1 Nut under test
- a Including chamfer, where *P* is the pitch
- b Chamfer to suit underhead radius

**Figure 5**

Tighten the nut to the torque quoted in the procurement specification with the aid of a socket wrench in accordance with ISO 691 or ISO 7403. Keep the nut under axial tension for the period quoted in the procurement specification.

At the end of this period, dismantle the assembly, then submit the nut to a visual examination and, if necessary, to an examination at a magnification of  $\times 10$  after sectioning to check conformity with the requirements of the procurement specification.

Nuts subjected to this test shall not be used again.

**3.6 Torque-out test**

This test applies only to nuts made from more than one part, either by design (floating anchor nuts or gang channel nuts), or by the needs of manufacture (fixed anchor nuts whose body is assembled to the baseplate by brazing or clinching).

It aims to check that the retention device is able to resist rotation of the threaded portion during tightening and untightening.

### 3.6.1 Test device

The test device is illustrated in Figure 6 and dimensions are given in Table 2.

The test device includes the following elements:

- a) a fixing plate;
- b) a shouldered mandrel threaded in accordance with ISO 5855-2<sup>1)</sup>;
- c) a locknut threaded in accordance with ISO 5855-2;
- d) rivets or bolts to fix the nut (no specific requirement).

### 3.6.2 Method

This test shall be carried out at ambient temperature.

Attach the nut or portion of channel to be tested on the plate by means of rivets or bolts. Lubricate the mandrel and nut threads as specified in Table 1 (if necessary). Screw in the mandrel so that the shoulder contacts the body of the nut (on bearing surface or bottom of counterbore). Apply the torque to the nut, in a tightening movement, as quoted in the procurement specification.

Assemble the locknut and apply to it the same torque in the reverse direction.

Dismantle the assembly, then submit the nut as well as the cage or the channel to a visual examination and, if necessary, to an examination at a magnification of  $\times 10$  after sectioning to check conformity with the requirements of the procurement specification.

Nuts subjected to this test shall not be used again.

Dimensions in millimetres

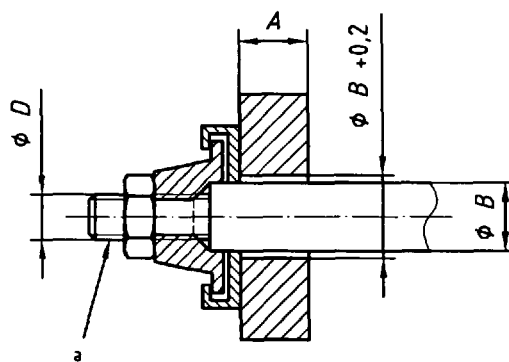

a Threaded length:  $\approx 3D$

Figure 6

### 3.7 Test of no rotation of the captive washer

This test applies only to nuts with captive washer.

- 1) A shouldered sleeve mounted on a bolt may also be used.

**Table 2 — Dimensions of the device for torque-out test**

Dimensions in millimetres								
<i>D</i>	3	3,5	4	5	6	7	8	10
<i>A</i> min.	6	6	8	8	8	14	14	14
<i>B</i> <sup>0</sup> <sub>-0,05</sub>	3,4	3,9	4,4	5,5	6,5	7,5	8,5	10,5

### 3.7.1 Test device

The test device includes the following elements:

- a) a bearing plate in usual sheet (light alloy with anodizing,  $Ra \leq 0,8 \mu\text{m}$  on the nut side), minimum thickness 2 mm;
- b) a spacer in steel (to compensate the bolt shank length excess);
- c) a bolt with characteristics as follows:
  - 1) threads: in accordance with ISO 5855-2,
  - 2) tensile strength class: at least equal to that of the nut to be tested,
  - 3) length between  $1,5D$  and  $3D$ .

### 3.7.2 Method

The test shall be carried out at ambient temperature.

Apply the squeeze torque to the nut to be tested as quoted in the procurement specification. Mark the washer position and apply a seating torque double to the torque applied for squeeze torque to the nut to be tested.

The bearing plate must be replaced for each test.

The test bolt may be reused several times if its threads don't have seams or traces of wear or seizing.

During application of the seating torque, the washer shall not rotate on the bearing plate.

### 3.8 Push-out test

This test applies only to gang channel nuts and anchor nuts with the exception of corner nuts shown in Figure 7 and reduced series single lug nuts.

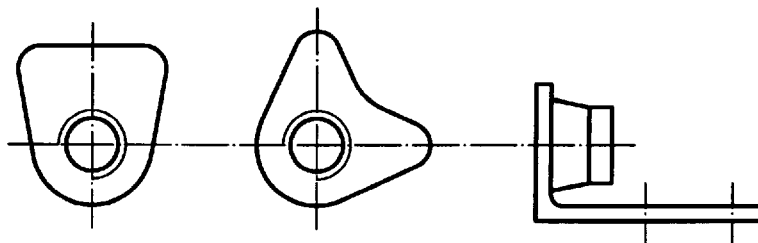

**Figure 7**

**3.8.1 Test device**

The test device is illustrated in Figure 8 and dimensions are given in Table 3.

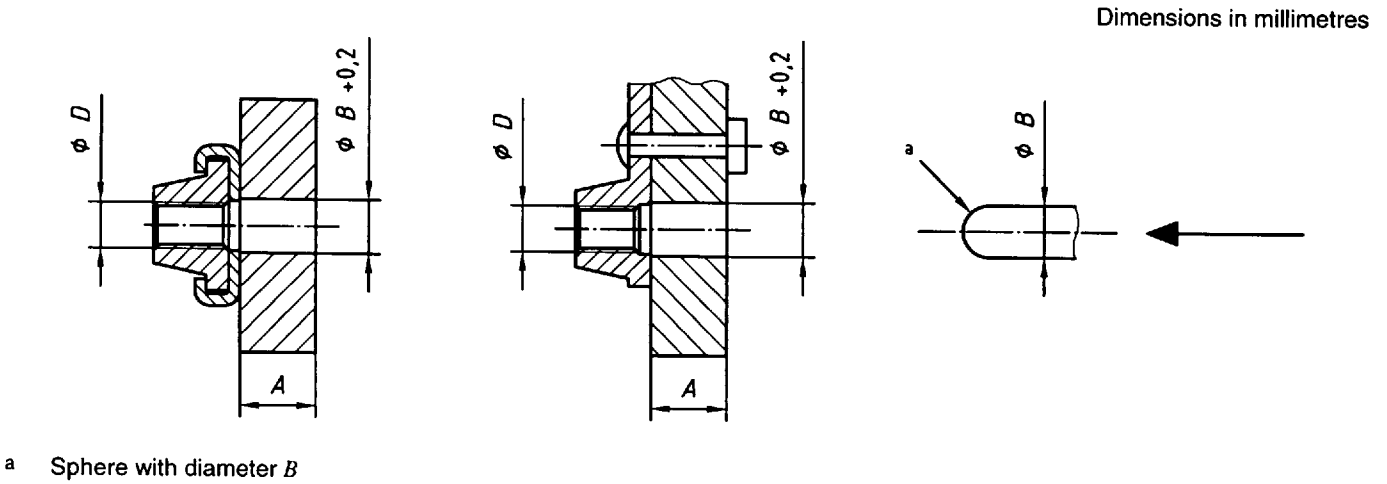

**Figure 8**

**Table 3 — Dimensions of the device for push-out test**

Dimensions in millimetres								
D	3	3,5	4	5	6	7	8	10
A min.	6	6	8	8	8	14	14	14
B <sup>0</sup> <sub>-0,05</sub>	3,4	3,9	4,4	5,5	6,5	7,5	8,5	10,5

The test device includes the following elements:

- a) a fixing plate;
- b) a push rod with spherical end;
- c) a bolt with the following characteristics:
  - 1) thread: in accordance with ISO 5855-2,
  - 2) tensile strength class: no specific requirement,
  - 3) material coating: no specific requirement;
- d) rivets or bolts to fix the nut (no specific requirement).

**3.8.2 Method**

This test shall be carried out at ambient temperature.

Attach the nut or the portion of channel to be inspected onto the plate by means of rivets or bolts. Apply the axial load quoted in the procurement specification using the rod with the spherical end.

**ISO 7481:2000(E)**

Ensure that any permanent deformation is not greater than the value allowed in the procurement specification using an appropriate feeler gauge.

Try to screw a standard bolt manually into the nut, even if deformed, as far as the locking device.

Dismantle, then subject the nut as well as the cage and the channel to a visual examination and, if necessary, examination at a magnification of  $\times 10$  after sectioning to check conformity with the requirements of the procurement specification.

Nuts subjected to this test shall not be used again.

**3.9 Self-locking torque at ambient temperature****3.9.1 Test device**

The test device is illustrated in Figure 9.

The test device includes the following elements:

- a) a steel spacer heat treated to a hardness  $\geq 40$  HRC (this may be a cylindrical sleeve or a block with parallel faces pierced with a series of holes);
- b) a bolt with the following characteristics:
  - 1) For the single cycle test:
    - i) thread: in accordance with ISO 5855-2 with the exception of the pitch diameter whose minimum and maximum dimensions are given in Table 4,
    - ii) tensile strength class: greater than or equal to that of the nut under test,
    - iii) material: non-coated alloy steel.
  - 2) For the multiple cycle test:
    - i) thread: in accordance with ISO 5855-2;
    - ii) tensile strength class: identical to that of the nut under test;
    - iii) material and coating: in accordance with Table 1.

**3.9.2 Method**

This test shall be carried out at ambient temperature. During the test, the nut temperature shall not exceed 45 °C.

**3.9.2.1 Single cycle test**

Lubricate the nut and bolt threads as stated in Table 1 (if necessary), then assemble the nut to the bolt after having added the spacer. Measure the self-locking torque when the protrusion is two pitches minimum (including chamfer). Apply the seating torque quoted in the procurement specification.

Remove the load by unscrewing a half turn and cease movement. Again unscrew and measure the breakaway torque.

Dismantle the assembly, then submit the bolt and nut to a visual examination and, if necessary, to an examination at a magnification of  $\times 10$  after sectioning to check conformity with the requirements of the procurement specification.



Surface rugosity given in micrometres

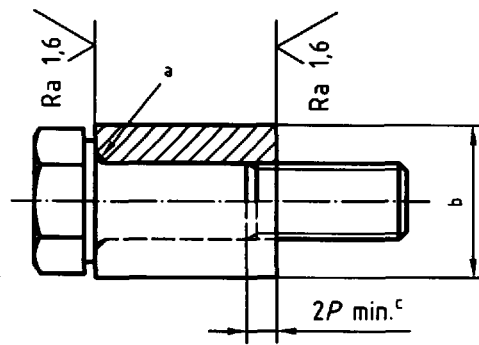

- a Chamfer to suit underhead radius
- b > bearing surface of nut
- c Where  $P$  is the pitch

Figure 9

Table 4 — Bolt dimensions for self-lockinbient temperature (single cycle test)

Dimensions in millimetres

Thread ( $d \times P$ )	Pitch diameter ( $d_2$ )	
	max.	min.
3 × 0,5	2,651	2,627
3,5 × 0,6	3,084	3,057
4 × 0,7	3,517	3,489
5 × 0,8	4,45	4,42
6 × 1	5,315	5,279
7 × 1	6,315	6,279
8 × 1	7,315	7,279
10 × 1,25	9,151	9,113
12 × 1,25	11,146	11,103
14 × 1,5	12,981	12,936
16 × 1,5	14,981	14,936
18 × 1,5	16,981	16,936
20 × 1,5	18,981	18,936
22 × 1,5	20,981	20,936
24 × 2	22,648	22,595
27 × 2	25,648	25,595
30 × 2	28,648	28,595
33 × 2	31,648	31,595
36 × 2	34,648	34,595
39 × 2	37,648	37,595

**ISO 7481:2000(E)****3.9.2.2 Multiple cycle test**

Proceed as stated in 3.9.2.1 repeating the cycle on the same bolt the number of times specified in the procurement specification, and measure the self-locking torque under the same conditions as the first assembly and at each disassembly. It is mandatory that the first assembly be carried out on a new bolt. Each disassembly shall be sufficient to entirely disengage the nut locking device.

Nuts having been subjected to the multiple cycle test shall not be used again.

**3.10 Self-locking torque at ambient temperature after heat soak at maximum operating temperature****3.10.1 Test device**

The test device consists of:

- a) the same spacer as for test 3.9 (see Figure 9);
- b) a bolt with the following characteristics:
  - 1) thread: in accordance with ISO 5855-2,
  - 2) tensile strength class: identical to that of the nut under test,
  - 3) material and coating: in accordance with Table 1.

**3.10.2 Method**

This test shall be carried out at ambient temperature.

Lubricate the nut and bolt threads as stated in Table 1 (if necessary), then assemble the nut to the bolt after having positioned the spacer. Measure the self-locking torque when the protrusion is two pitches minimum (including chamfer). Apply the seating torque quoted in the procurement specification.

Heat the assembly to the maximum operating temperature quoted in the dimensional standard or drawing of the nut  $\pm 5$  °C and maintain it at this temperature for the period given below:

- nuts locked by plastic ring: 3 h  $\pm$  15 min.;
- all metal self-locking nuts: 6 h  $\pm$  15 min.

Remove the assembly from the oven and allow it to cool slowly to ambient temperature.

Remove the load by unscrewing a half turn and cease movement. Begin again to unscrew and measure the breakaway torque.

Remove the nut.

Repeat the cycle the number of times stated in the procurement specification and measure the self-locking torque at each cycle under the same conditions.

Dismantle, then submit the bolt and nut to a visual examination and, if necessary, to an examination at a magnification of  $\times 10$  after sectioning to check conformity with the requirements of the procurement specification.

Nuts subjected to this test shall not be used again.

### 3.11 Permanent set test

This test details the method for checking the thread possibility of reuse of self-locking nuts on bolts whose thread is at the tolerance limit.

#### 3.11.1 Test device

The test device consists of a maximum and minimum threaded mandrel, in conformity with Figure 10, whose characteristics are as follows:

- a) threads: in accordance with ISO 5855-2, with the exception of the pitch diameter and tolerances that shall be in accordance with the values stated in Table 5;
- b) material: steel heat-treated to a hardness  $\geq 39$  HRC.

Dimensions in millimetres

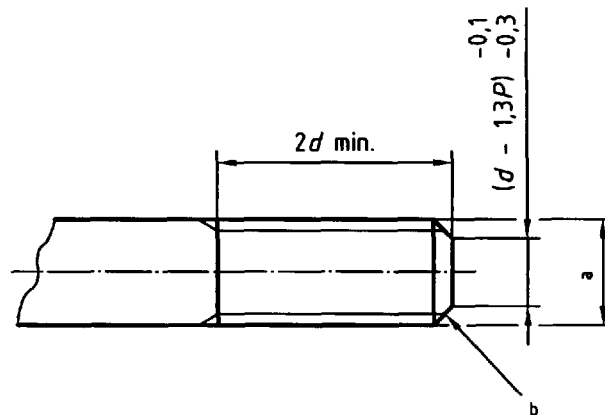

- a Thread
- b Remove sharp edges if thread is machined.

Figure 10

This test also may be carried out with a bolt of tensile strength class equal to or greater than that of the nut to be tested at the condition their pitch diameter is inside the tolerance given Table 5. However, in case of dispute, only the results obtained with the mandrels in steel, heat-treated, shall be taken into consideration.

#### 3.11.2 Method

This test shall be carried out at ambient temperature.

Check that the mandrel dimensions are within the limits given in the Table 5 and that their threads have not been damaged.

Lubricate the nut threads and the maximum mandrel threads as stated in Table 1 (if necessary). Assemble the nut to the maximum mandrel and measure the locking torque when the protrusion is two pitches minimum (including chamfer). Then unscrew the nut.

Lubricate the nut threads and the minimum mandrel threads as stated in Table 1 (if necessary). Assemble the nut to the minimum mandrel with a protrusion of two pitches minimum (including chamfer). Then measure the breakaway torque in the unscrewing direction.

Remove the nut, then submit it to a visual examination and, if necessary, to an examination at a magnification of  $\times 10$  after sectioning to check conformity with the requirements of the procurement specification.

Nuts subjected to this test shall not be used again.

**Table 5 — Dimensions of the mandrels for permanent set test**

Dimensions in millimetres

Thread ( $d \times P$ )	Pitch diameter $d_2$ $\begin{matrix} 0 \\ -0,01 \end{matrix}$		Tolerance	
	Maximum mandrel	Minimum mandrel	on half angle	on pitch
3 × 0,5	2,662	2,627	± 15'	± 0,008 whatever the pitch
3,5 × 0,6	3,096	3,057		
4 × 0,7	3,53	3,489		
5 × 0,8	4,464	4,42		
6 × 1	5,333	5,279		
7 × 1	6,333	6,279		
8 × 1	7,332	7,279		
10 × 1,25	9,169	9,113		
12 × 1,25	11,167	11,103		
14 × 1,5	13,003	12,936	± 10'	
16 × 1,5	15,002	14,936		
18 × 1,5	17,001	16,936		
20 × 1,5	19	18,936		
22 × 1,5	20,999	20,936		
24 × 2	22,673	22,595		
27 × 2	25,672	25,595		
30 × 2	28,67	28,595		
33 × 2	31,67	31,595		
36 × 2	34,67	34,595		
39 × 2	37,67	37,595		

**3.12 Vibration test**

Taking into account the capacity of vibration machines, this test applies only to nuts of diameter 5 mm, 6 mm, 7 mm, 8 mm, 10 mm and 12 mm.

For nuts of different diameter, the capability of resisting vibration is evaluated from results obtained on one or more of the aforementioned diameters, on condition that these nuts are of identical design and manufacture.

**3.12.1 Test device**

The test device is shown in Figure 11 and dimensions are given in Table 6.

The test device includes the following elements:

- a) a block with parallel surfaces in which oblong openings have been made;
- b) spacers;
- c) washers;

d) bolts with the following characteristics:

- 1) threads: in accordance with ISO 5822-2,
- 2) tensile strength class: identical with that of the nut under test,
- 3) material and coating: in accordance with Table 1.

Each spacer is held captive in the block by the addition of the washer on the side opposite the shoulder, the two parts being assembled by the use of the bolt and the nut under test, as shown in Figure 12.

The assembly (block plus assembled spacers) is submitted to vibration with the following characteristics:

- form: sinusoidal;
- frequency: 30 Hz;
- total movement:  $(11,43 \pm 0,4)$  mm.

The test device shall be positioned in such a way that displacement is vertical.

Dimensions in millimetres, surface rugosity in micrometres

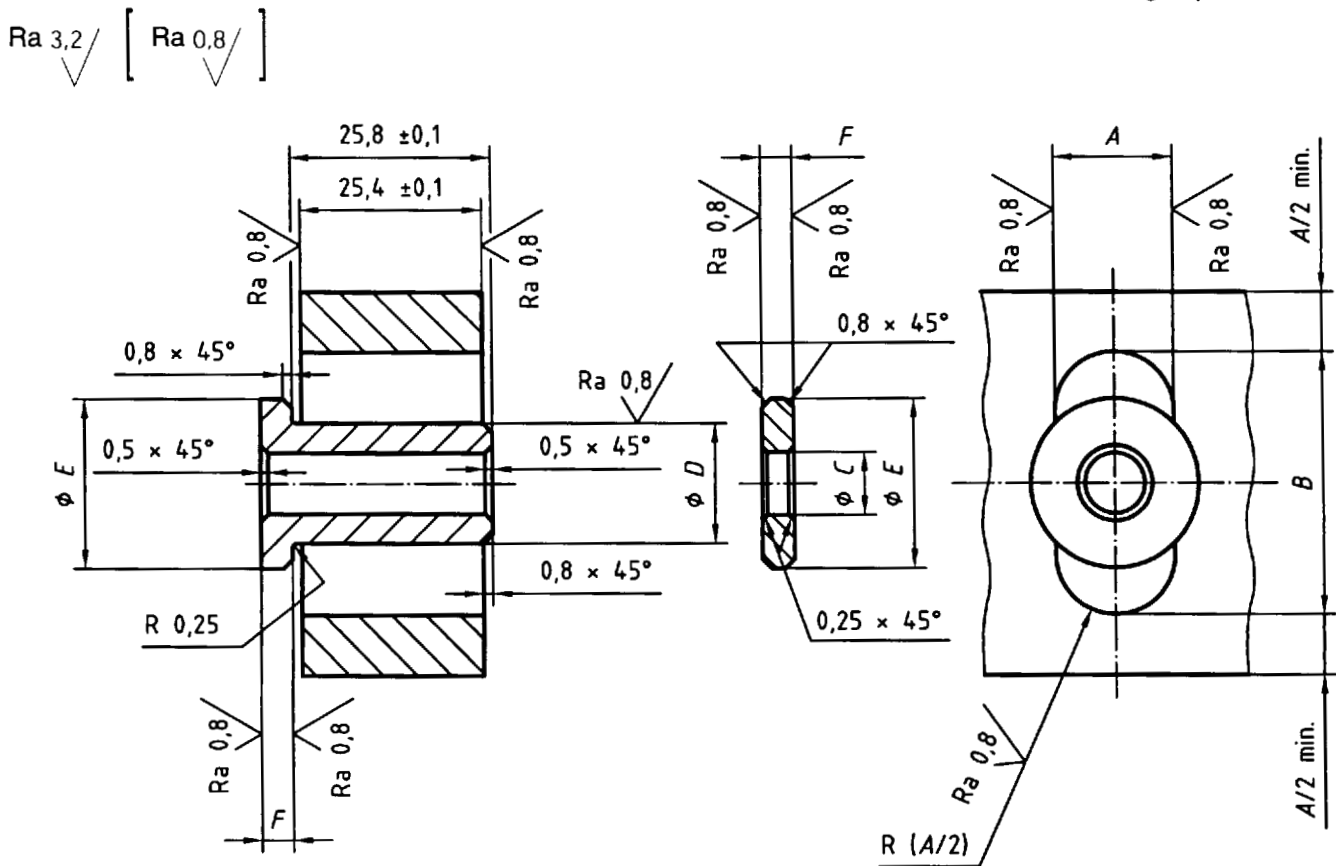

NOTE Material: steel heat-treated to a hardness  $\geq 40$  HRC.

Figure 11

Table 6 — Dimensions of the device for vibration test

Dimensions in millimetres

Nominal thread diameter	A +0,15 0	B +0,1 0	C +0,1 0	D 0 -0,01	E 0 -0,25	F 0 -0,01
5	8,29	27,16	5,2	8,22	14,09	3,17
6	12,65	31,58	6,3	12,62	19,17	4,19
7	14,25	33,18	7,3	14,22	20,77	
8	15,83	34,75	8,3	15,79	22,35	
10	19	37,92	10,3	18,97	25,52	4,82
12	25,35	44,28	12,3	25,19	35,05	

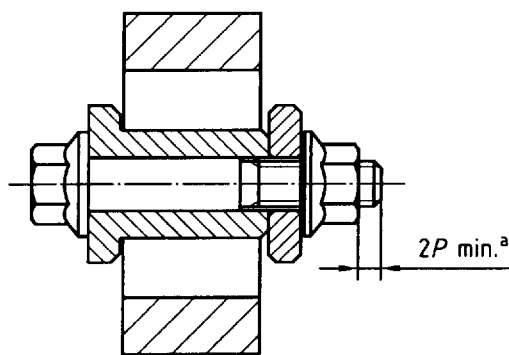

<sup>a</sup> Including chamfer, where  $P$  is the pitch.

Figure 12

### 3.12.2 Method

This test shall be carried out at ambient temperature.

Certain types of nuts will require preparation in the following manner:

- floating nuts shall be extracted from their cage or channel;
- lugs from plate nuts shall be sawed symmetrically about the axis;
- shanks of clinch nuts shall be flushed off at the level of the bearing surface.

#### 3.12.2.1 All metal self-locking nuts

Lubricate the nut and bolt threads as stated in Table 1 (if necessary) and assemble the nut to the bolt with a protrusion of two pitches minimum (including chamfer). Heat the assembly to the maximum operating temperature stated in the dimensional standard or drawing of the nut  $\pm 5^\circ\text{C}$ , and maintain at this temperature for a period of  $6\text{ h} \pm 15\text{ min}$ . Allow to cool slowly outside the oven to ambient temperature, then remove the nut.

Assemble the nut to the same bolt, under the same lubrication conditions, after having positioned the spacer and the washer. Apply the tightening torque quoted in the procurement specification. Untighten the nut and unscrew so as to completely disengage the locking feature.

Repeat the tighten / untighten cycle three times and then carry out a fourth tightening, always on the same bolt, after mounting the assembly in the slot in the block. Mark a reference line over the end of the bolt onto the nut. Lightly lubricate the friction surfaces with synthetic oil and check that the spacer moves freely within its slot.

Fix the assembly on the vibration-generating equipment (vibration table or any other appropriate apparatus) and submit the assembly to the vibratory regime for a period of 16 min 40 s, which corresponds with 30 000 cycles. Check throughout the test that the assembly moves freely within the slots.

If a nut unscrews completely, stop the test, pick up the defective nut and the failed parts of the assembly, then continue the test on the other nuts for a period equal to that remaining. At the end of the period, stop the test and remove the assembly from the vibration generating equipment. Examine the assemblies and any rotation of the nut relative to the bolt.

Finally, unscrew the nuts, then submit them to a visual examination and, if necessary, to an examination at a magnification of  $\times 10$  after sectioning to check conformity with the requirements of the procurement specification.

### **3.12.2.2 Nuts locked by plastic ring**

Proceed as listed in 3.12.2.1, without submitting the nuts to the prior heat soak. Each nut shall therefore be submitted to four tighten /untighten cycles and a fifth tightening to the torque quoted in the procurement specification, still on the same bolt, before being tested in vibration.

Nuts subjected to this test shall not be used again.

**ISO 7481:2000(E)**

---

**ICS 49.030.30**

Price based on 18 pages

© ISO 2000 – All rights reserved