**Building construction — Jointing
products — Determination of resistance to
flow of sealants**

*Construction immobilière — Produits pour joints — Détermination de la
résistance au coulage des mastics*



Reference number
ISO 7390:2002(E)

© ISO 2002

PDF disclaimer

This PDF file may contain embedded typefaces. In accordance with Adobe's licensing policy, this file may be printed or viewed but shall not be edited unless the typefaces which are embedded are licensed to and installed on the computer performing the editing. In downloading this file, parties accept therein the responsibility of not infringing Adobe's licensing policy. The ISO Central Secretariat accepts no liability in this area.

Adobe is a trademark of Adobe Systems Incorporated.

Details of the software products used to create this PDF file can be found in the General Info relative to the file; the PDF-creation parameters were optimized for printing. Every care has been taken to ensure that the file is suitable for use by ISO member bodies. In the unlikely event that a problem relating to it is found, please inform the Central Secretariat at the address given below.

© ISO 2002

All rights reserved. Unless otherwise specified, no part of this publication may be reproduced or utilized in any form or by any means, electronic or mechanical, including photocopying and microfilm, without permission in writing from either ISO at the address below or ISO's member body in the country of the requester.

ISO copyright office
Case postale 56 • CH-1211 Geneva 20
Tel. + 41 22 749 01 11
Fax + 41 22 749 09 47
E-mail copyright@iso.ch
Web www.iso.ch

Printed in Switzerland

Foreword

ISO (the International Organization for Standardization) is a worldwide federation of national standards bodies (ISO member bodies). The work of preparing International Standards is normally carried out through ISO technical committees. Each member body interested in a subject for which a technical committee has been established has the right to be represented on that committee. International organizations, governmental and non-governmental, in liaison with ISO, also take part in the work. ISO collaborates closely with the International Electrotechnical Commission (IEC) on all matters of electrotechnical standardization.

International Standards are drafted in accordance with the rules given in the ISO/IEC Directives, Part 3.

Draft International Standards adopted by the technical committees are circulated to the member bodies for voting. Publication as an International Standard requires approval by at least 75 % of the member bodies casting a vote.

Attention is drawn to the possibility that some of the elements of this International Standard may be the subject of patent rights. ISO shall not be held responsible for identifying any or all such patent rights.

International Standard ISO 7390 was prepared by Technical Committee ISO/TC 59, *Building construction*, Subcommittee SC 8, *Jointing products*.

This third edition cancels and replaces the second edition (ISO 7390:1987), which has been technically revised.

Building construction — Jointing products — Determination of resistance to flow of sealants

1 Scope

This International Standard specifies a method for the determination of the resistance to flow of sealants, by loss of cohesion under their own weight. These sealants are used in joints in vertical surfaces in building construction.

2 Normative reference

The following normative document contains provisions which, through reference in this text, constitute provisions of this International Standard. For dated references, subsequent amendments to, or revisions of, this publication do not apply. However, parties to agreements based on this International Standard are encouraged to investigate the possibility of applying the most recent edition of the normative document indicated below. For undated references, the latest edition of the normative document referred to applies. Members of ISO and IEC maintain registers of currently valid International Standards.

ISO 6927, *Building construction — Jointing products — Sealants — Vocabulary*

3 Terms and definitions

For the purposes of this International Standard, the terms and definitions for sealants specified in ISO 6927 apply.

4 Principle

The sealant, applied in a U-profile, is exposed for a defined time to various defined temperatures. The open surface of the sealant is in a vertical position during the test. The flow of the sealant out of the U-profile is measured at the end of the test period.

5 Apparatus

5.1 Non-porous and smooth U-profiles, for example anodized or non-anodized aluminium, with a length of $(150 \pm 1,0)$ mm, with both ends open and optionally the back surface extended at one end (see Figures 1 and 2), having a cross section with the following internal dimensions:

- width: $(20 \pm 0,2)$ mm;
- depth: $(10 \pm 0,2)$ mm.

Other dimensions may be applied, for example width $(10 \pm 0,2)$ mm and depth $(10 \pm 0,2)$ mm.

5.2 Strips of polyethylene (PE) sheet, with the following dimensions:

- thickness $\leq 0,5$ mm;
- width to cover the inner backside of the U-profile.

Under test conditions, the length of the PE-strip shall not change by more than 1 mm.

5.3 Ventilated convection-type oven, capable of operating at (70 ± 2) °C.

5.4 Ventilated convection-type oven, capable of operating at (50 ± 2) °C.

5.5 Refrigerated container, capable of operating at (5 ± 2) °C.

5.6 Measuring device, scaled in 0,5 mm.

6 Test method

6.1 Preparation of test specimens

The appropriate number of U-profiles used is determined according to 6.2. The U-profiles shall be first cleaned and dried.

Place a strip of PE-sheet (5.2) along the backside base of each U-profile, overlapping at the top and fixed at the outer reverse side, for example with adhesive tape. The PE-strip shall exactly cover the inside base of the U-profile.

NOTE If the PE-strip is too narrow, the sealant will adhere to the backside base of the U-profile. If the PE-strip is too wide, it will curl inwards decreasing the contact area between the sealant and the sides of the U-profile.

Bring the U-profile and the sealant to (23 ± 2) °C. Fill the U-profile with sealant. The following precautions shall be taken:

- a) the formation of air bubbles shall be avoided;
- b) the sealant shall be pressed on the inner profile surfaces;
- c) the sealant surface shall be trimmed so that it is flush with the face and ends of the U-profile;
- d) the polyethylene strip shall be loosened from the reverse side of the U-profile.

6.2 Procedures

6.2.1 General

For each test temperature of 70 °C and/or 50 °C and/or 5 °C, and for each procedure A and B, one test specimen shall be used.

The test specimens shall be tested either according to procedure A (see 6.2.2) or procedure B (see 6.2.3), as agreed.

In the case of the sealant sliding from the U-profile, the inner surface of the U-profile shall be treated in accordance with the sealant manufacturer's recommendations. The test shall be repeated.

6.2.2 Procedure A

Immediately after the preparation (6.1), place the test specimen in the oven (5.3 or 5.4) or in the refrigerated container (5.5) in a vertical position with the possible extension of the U-profile at the bottom (see Figure 1).

Submit each test specimen to each defined test temperature for 24 h and then remove it from the oven or refrigerated container.

Measure in a vertical direction, using the measuring device (5.6), the distance that the bottom edge of the sealant of each test specimen has moved downwards.

Dimensions in millimetres

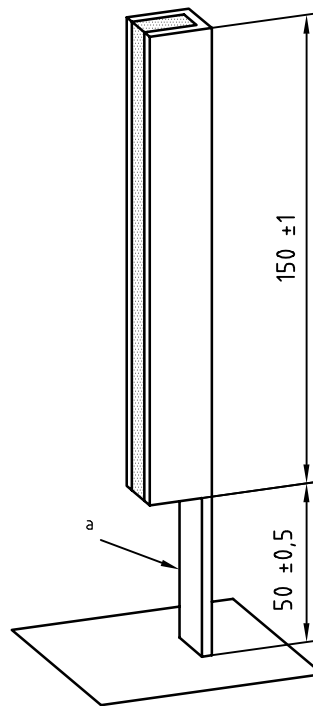
^a Optional**Figure 1 — Position of test specimen for procedure A****6.2.3 Procedure B**

Immediately after the preparation (6.1), place the test specimen in the oven (5.3 or 5.4) or in the refrigerated container (5.5), in a horizontal position with the open sealant surface in a vertical plane (see Figure 2).

Dimensions in millimetres

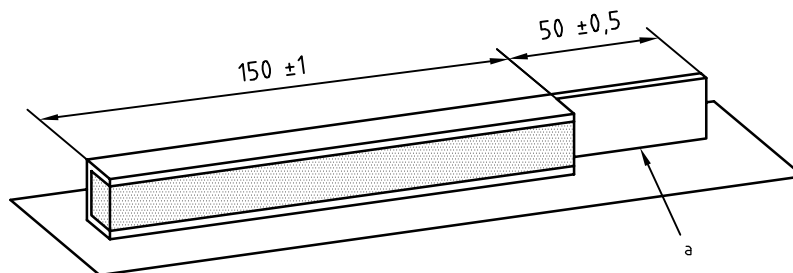
^a Optional**Figure 2 — Position of test specimen for procedure B**

Submit each test specimen to each defined test temperature for 24 h and then remove it from the oven or refrigerated container.

Measure in a horizontal direction, using the measuring device (5.6), the distance that the sealant has projected beyond the front of the U-profile of each test specimen.

7 Test report

The test report shall contain the following information:

- a) name of laboratory and date of test;
- b) a reference to this International Standard;
- c) name, type (chemical family) and colour of sealant;
- d) batch of sealant from which the test specimens were produced;
- e) type of profile used (anodized or non-anodized aluminium or other material);
- f) internal dimensions of U-profiles if different from those in 5.1;
- g) applied procedure according to 6.2;
- h) name and batch of the surface treatment, if any;
- i) flow of the sealant of each test specimen, in millimetres rounded to the nearest 1 mm, stating the test temperature used;
- j) any deviations from the method of this International Standard.

ISO 7390:2002(E)

ICS 91.100.50

Price based on 4 pages

© ISO 2002 – All rights reserved

Als Papierkopie - kein Änderungsdienst / Printed copy - no alert service