

# International Standard



# 7382

INTERNATIONAL ORGANIZATION FOR STANDARDIZATION • МЕЖДУНАРОДНАЯ ОРГАНИЗАЦИЯ ПО СТАНДАРТИЗАЦИИ • ORGANISATION INTERNATIONALE DE NORMALISATION

## Ethylene for industrial use — Sampling in the liquid and the gaseous phase

*Éthylène à usage industriel — Échantillonnage en phase liquide et en phase gazeuse*

First edition — 1986-09-15

UDC 661.716.2 : 543.05

Ref. No. ISO 7382-1986 (E)

Descriptors : industrial products, chemical compounds, ethylene, sampling, sampling equipment.

Price based on 6 pages

## Foreword

ISO (the International Organization for Standardization) is a worldwide federation of national standards bodies (ISO member bodies). The work of preparing International Standards is normally carried out through ISO technical committees. Each member body interested in a subject for which a technical committee has been established has the right to be represented on that committee. International organizations, governmental and non-governmental, in liaison with ISO, also take part in the work.

Draft International Standards adopted by the technical committees are circulated to the member bodies for approval before their acceptance as International Standards by the ISO Council. They are approved in accordance with ISO procedures requiring at least 75 % approval by the member bodies voting.

International Standard ISO-7382 was prepared by Technical Committee ISO/TC 47, *Chemistry*.

Users should note that all International Standards undergo revision from time to time and that any reference made herein to any other International Standard implies its latest edition, unless otherwise stated.

# Ethylene for industrial use — Sampling in the liquid and the gaseous phase

**WARNING** — In putting the operating techniques described in this International Standard into practice, it is mandatory to take account of the current official regulations.

## 1 Scope and field of application

This International Standard describes the procedures and the precautions to be taken in drawing representative samples of ethylene in the liquid phase stored at  $-100\text{ }^{\circ}\text{C}$  and in the gaseous phase, for the purpose of their analysis excluding the determination of water content, other polar components and hydrocarbons heavier than  $\text{C}_6$  [for the preparation of samples for the determination of water or polar compounds, use ISO 8916 (see clause 5)].

It also sets out, in annex, a diagrammatic representation of a system for the removal of the portion of the sample not used in the analysis.

## 2 Sampling from a container filled with ethylene in the liquid phase

### 2.1 Safety measures

The ethylene shall be stored and transported in the liquid phase at a temperature below  $-100\text{ }^{\circ}\text{C}$ .

The critical temperature of ethylene is  $9,5\text{ }^{\circ}\text{C}$  and its critical pressure is  $10,5\text{ MPa}^*$ . As the boiling temperature of ethylene at atmospheric pressure is  $-103,9\text{ }^{\circ}\text{C}$ , it follows that ethylene sampled in the liquid phase cannot be kept in that state at room temperature, without taking account of the pressure. All sampling equipment shall be capable of resisting the sample pressure after complete vaporization.

The construction materials shall be capable of withstanding rapid changes in temperature, for example, rising from  $-100\text{ }^{\circ}\text{C}$  to  $+20\text{ }^{\circ}\text{C}$  in 1 to 2 min. Passivated stainless steel should be selected for preference.

Owing to the low temperatures of the product and its associated equipment, operators shall wear well-insulating, non-cracking plastics or rubber-coated gloves to protect themselves from burns. They shall also wear close-fitting protective goggles.

Ethylene is extremely flammable, and all precautions shall be taken to avoid forming an explosive atmosphere. Suitable ventilation is essential, particularly during the purging operations.

Also, the sample cylinder shall always be connected to earth by means of an equipotential clamp.

\*  $1\text{ MPa} = 10\text{ bar}$

## 2.2 Apparatus and procedures

The two sampling apparatus described below have been found satisfactory and are available commercially.

### 2.2.1 Sampling apparatus No. 1

The apparatus is shown in figure 1 and is composed of the following parts:

A cylinder tested at  $34,5\text{ MPa}$ , of  $0,15$  to  $1$  litre capacity. This cylinder shall be fitted with one dip pipe, marked on the cylinder, ending at  $30\%$  of the distance from the base, and ensuring that the cylinder can be filled to only  $30\%$  of its capacity. An inlet valve A is fitted to the cylinder, and an outlet valve B to the dip pipe.

To aid handling and to protect the operator from low temperature burns, the cylinder shall be fitted with a foot and one or two handles.

A passivated stainless steel connecting pipe  $2\text{ m}$  long and  $4\text{ mm}$  internal diameter, with threaded joints, is joined to the ethylene tank (valves P and P') and to the inlet valve A of the cylinder.

A T-union is fitted into the above pipe as close as possible to valve A of the cylinder, to connect a stainless steel vent line  $50\text{ cm}$  long and  $4\text{ mm}$  internal diameter to a valve Q.

A stainless steel vent line  $50\text{ cm}$  long and  $4\text{ mm}$  internal diameter is fitted to the drainage valve B of the cylinder.

### 2.2.2 Procedure

Open the valve P then the valve P' at the point of sampling and slowly open the valve Q of the vent line, in order to purge the sampling line.

Avoid excessive purging, which would cause ice formation at the outside or on the internal parts of the valve and also a pollution of the atmosphere.

As soon as the liquid ethylene appears at the vent line close valve Q.

Open valve B completely.

## ISO 7382-1986 (E)

Slowly open valve A and allow the cylinder to fill.

As soon as the liquid ethylene appears at the second vent line close valve A and, only afterwards, valve B.

Close valves P' and P at the sampling point, open valve Q and disconnect the cylinder.

### 2.2.3 Sampling apparatus No. 2

The apparatus is shown in figure 2 and is composed of the following parts:

A cylinder A of 150 ml capacity, tested at 34,5 MPa, fitted with an inlet valve  $V_1$ , an outlet valve  $V_2$  and a safety valve system under load, to operate at about 10 MPa.

An insulating jacket is fitted around the cylinder A to maintain the low temperature.

A second cylinder B of 1 000 ml capacity, tested at 12,5 MPa, fitted with an outlet valve  $V_3$  and a safety valve system.

A short stainless steel pipe connected to the outlet pipe immediately after the safety valve of the cylinder A but before valve 2 which is connected to the inlet of the cylinder B. It incorporates a manometer C of 0 to 50 MPa, a valve  $V_4$  and a manometer D of 0 to 20 MPa.

### 2.2.4 Procedure

Connect the sampling apparatus to the ethylene tank and close valve  $V_2$ , the outlet valve of the liquid ethylene, and open valve  $V_3$ , the outlet valve from the cylinder containing vaporized ethylene. Open the inlet valve  $V_1$  of the liquid ethylene cylinder and regulate this so as to obtain a slow purge of ethylene vapour through the sampling apparatus for a period of 5 min.

Open valve  $V_2$  and close valve  $V_3$  when the pressure is just positive at the outlet.

When the liquid ethylene is discharged from valve  $V_2$ , continue the purge for a further 5 min, then close valve  $V_1$  and valve  $V_2$  in that order.

Close the sampling point, relieve the pressure and disconnect the apparatus.

Remove the insulating jacket from cylinder A. There should normally be a progressive accumulation of pressure from 3,5 to 4,5 MPa, measured at gauge D. In order to complete vaporization, cylinder A can be heated with a row of steam jets.

If the pressure rises rapidly to 7,0 MPa, measured at gauge C, open valve 1 and then valve 2.

### 2.3 Maintenance of the sampling apparatus

It has been found that the cylinders of ethylene may be contaminated by oil, water or solvents when they have been used for a certain time. This can cause irregularity in the results of subsequent analyses. If contamination is suspected, the cylinder can be cleansed by purging with a flow of superheated steam followed by dry nitrogen while the cylinder is still hot. The new cylinder can be made air-free by purging with an inert gas: helium, argon or nitrogen, preferably while bringing the cylinder to a pressure of 10 MPa and purging. This operation should be carried out three times.

## 3 Sampling of ethylene in the gaseous phase

Although the most general practice is to carry out the sampling in the liquid phase, it can sometimes be advantageous, when permitted by the safety regulations and only a small portion of the sample is required, to draw a sample directly in the gaseous phase (see the diagrammatic representation given as an example in figure 3).

For this case, the procedure is as follows:

Draw the sample with the aid of an adjustable valve, which should be mounted at the outlet of the gas sampling pipe in such a way that discharge is upwards.

The gas sampling pipe should be connected to the ethylene tank by a silicone tube (or polytetrafluoroethylene tube) which is as short as possible. This part of the tube should be used once only, in order to avoid any transfer of traces of impurities in the samples, which would become non-representative.

If the distance between the valve and the gas sampling pipe cannot be kept below 20 cm, use a suitable glass tube in place of the silicone tube.

Before taking a representative sample, purge the sampling pipes with an amount of sample gas equal to at least 20 times the volume of the sampling pipe.

## 4 Sampling report

A sampling report shall be written containing all essential information pertaining to the material sampled. It shall contain at least the following particulars:

- a) reference to this International Standard;
- b) unambiguous sample identification such as name and number of the label on the sampling bottle;
- c) date and duration of sampling;
- d) approximate size of consignment;
- e) comments on abnormalities such as obvious contamination;
- f) any operation not included in this International Standard or regarded as optional.

## 5 Bibliography

ISO 8916, *Ethylene for industrial use — Determination of traces of water and polar compounds — Preparation of condensate samples by low-temperature scrubbing technique.* (At present at the stage of draft.)

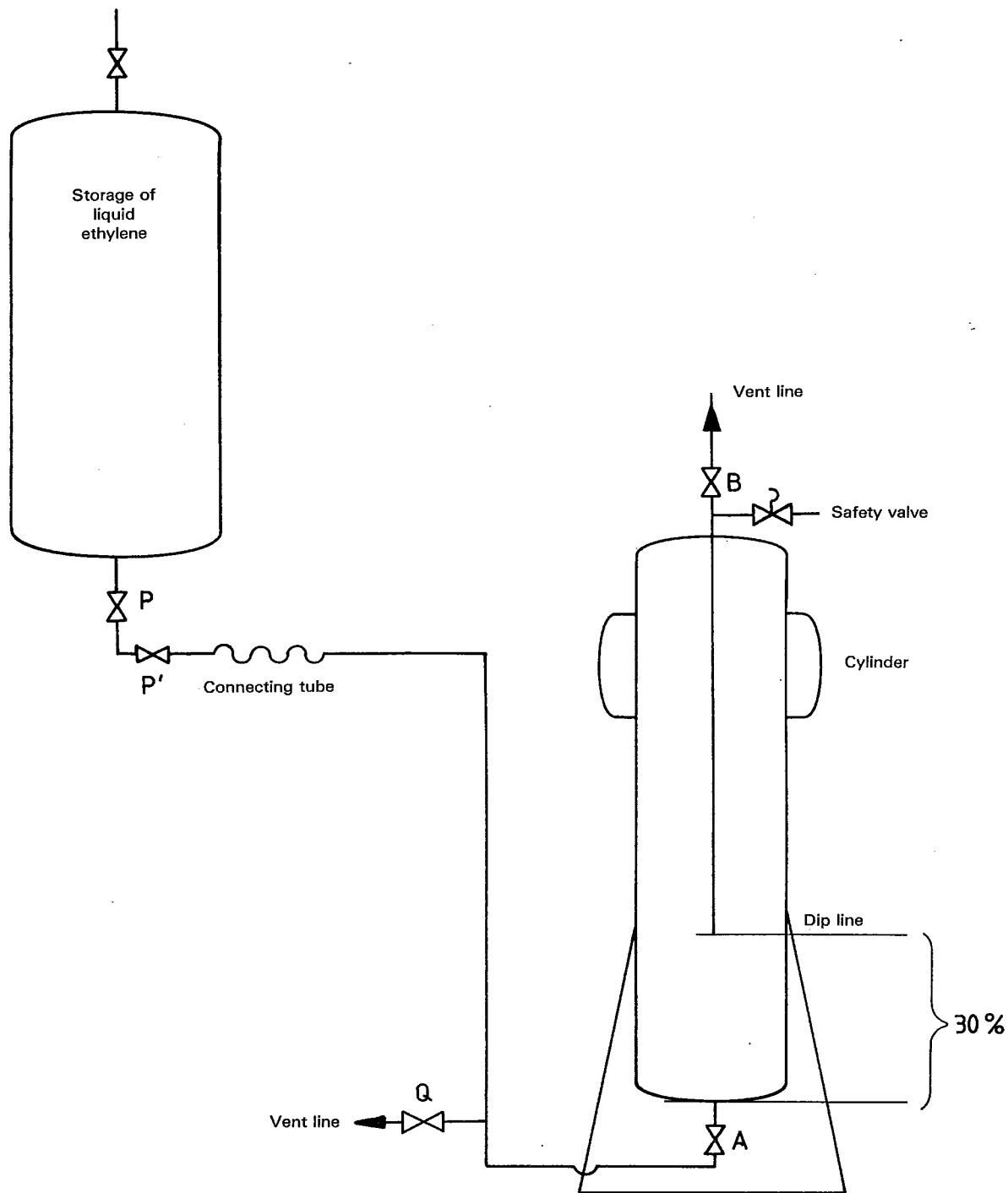

Figure 1 — Sampling apparatus No. 1 for liquid ethylene

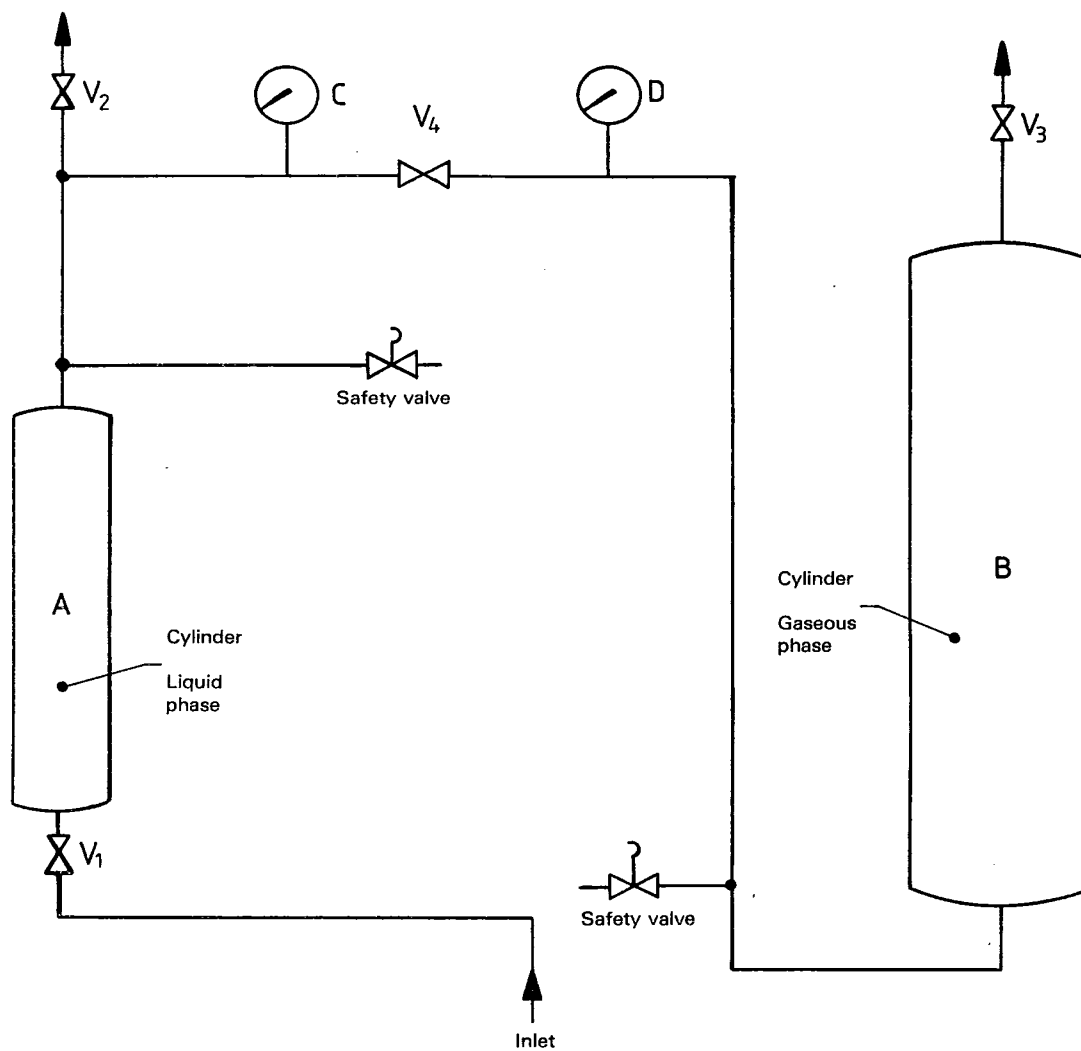

Figure 2 — Sampling apparatus No. 2 for liquid ethylene

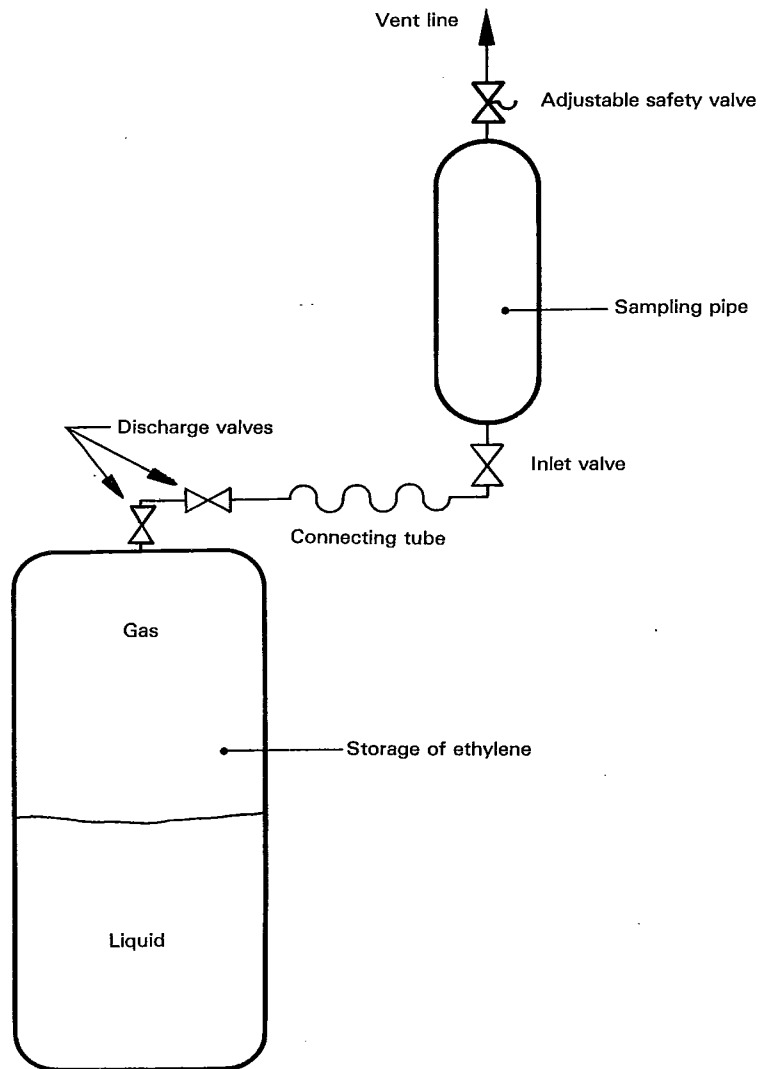

Figure 3 — Diagrammatic representation of sampling of ethylene in the gaseous phase

## Annex

## System for the removal of samples of liquefied or gaseous light olefins

(This annex forms an integral part of the Standard.)

NOTE — The air and water vapour pressures are given for information.

**WARNING** — Before purging the cylinders, it is imperative to connect them to earth by means of an equipotential clamp.**Drainage system:** Suitable flexible connection according to the cylinder used**Ejector to air:** Standard model.