

INTERNATIONAL
STANDARD

ISO
7368

Second edition
2016-08-01

**Hydraulic fluid power — Two-port
slip-in cartridge valves — Cavities**

*Transmissions hydrauliques — Distributeurs à cartouche, à bride, à
deux orifices — Logements*



Reference number
ISO 7368:2016(E)

© ISO 2016



COPYRIGHT PROTECTED DOCUMENT

© ISO 2016, Published in Switzerland

All rights reserved. Unless otherwise specified, no part of this publication may be reproduced or utilized otherwise in any form or by any means, electronic or mechanical, including photocopying, or posting on the internet or an intranet, without prior written permission. Permission can be requested from either ISO at the address below or ISO's member body in the country of the requester.

ISO copyright office
Ch. de Blandonnet 8 • CP 401
CH-1214 Vernier, Geneva, Switzerland
Tel. +41 22 749 01 11
Fax +41 22 749 09 47
copyright@iso.org
www.iso.org

Contents

Page

Foreword	iv
Introduction	v
1 Scope	1
2 Normative references	1
3 Terms and definitions	1
4 Symbols	1
5 Tolerances	2
6 Dimensions	2
7 Identification statement (Reference of this International Standard)	3
Bibliography	36

Foreword

ISO (the International Organization for Standardization) is a worldwide federation of national standards bodies (ISO member bodies). The work of preparing International Standards is normally carried out through ISO technical committees. Each member body interested in a subject for which a technical committee has been established has the right to be represented on that committee. International organizations, governmental and non-governmental, in liaison with ISO, also take part in the work. ISO collaborates closely with the International Electrotechnical Commission (IEC) on all matters of electrotechnical standardization.

The procedures used to develop this document and those intended for its further maintenance are described in the ISO/IEC Directives, Part 1. In particular the different approval criteria needed for the different types of ISO documents should be noted. This document was drafted in accordance with the editorial rules of the ISO/IEC Directives, Part 2 (see www.iso.org/directives).

Attention is drawn to the possibility that some of the elements of this document may be the subject of patent rights. ISO shall not be held responsible for identifying any or all such patent rights. Details of any patent rights identified during the development of the document will be in the Introduction and/or on the ISO list of patent declarations received (see www.iso.org/patents).

Any trade name used in this document is information given for the convenience of users and does not constitute an endorsement.

For an explanation on the meaning of ISO specific terms and expressions related to conformity assessment, as well as information about ISO's adherence to the World Trade Organization (WTO) principles in the Technical Barriers to Trade (TBT) see the following URL: www.iso.org/iso/foreword.html.

The committee responsible for this document is ISO/TC 131, *Fluid power systems*, Subcommittee SC 5, *Control products and components*.

This second edition cancels and replaces the first edition (ISO 7368:1989), which has been technically revised.

This edition includes the following significant changes with respect to the previous edition:

- New sizes 15 and 16 are introduced;
- Surface tolerances for sealing purposes are aligned with ISO 3601-2.

Introduction

In hydraulic fluid power systems, power is transmitted and controlled through a liquid under pressure within an enclosed circuit. Typical components found in such systems are hydraulic valves. These devices control flow direction, pressure or flow rate of liquids in the enclosed circuit.

Hydraulic fluid power — Two-port slip-in cartridge valves — Cavities

1 Scope

This document specifies only geometrical data relating to cavities in which two-port hydraulic slip-in cartridge valves are mounted in order to ensure interchangeability.

NOTE For example, this document does not specify rated pressures.

It applies to cavities for two-port hydraulic slip-in cartridge valves which are generally applicable to industrial equipment.

2 Normative references

The following documents are referred to in the text in such a way that some or all of their content constitutes requirements of this document. For dated references, only the edition cited applies. For undated references, the latest edition of the referenced document (including any amendments) applies.

ISO 1302, *Geometrical Product Specifications (GPS) — Indication of surface texture in technical product documentation*

ISO 2768-1, *General tolerances — Part 1: Tolerances for linear and angular dimensions without individual tolerance indications*

ISO 3601-2, *Fluid power systems — O-rings — Part 2: Housing dimensions for general applications*

ISO 4287, *Geometrical Product Specifications (GPS) — Surface texture: Profile method — Terms, definitions and surface texture parameters*

3 Terms and definitions

For the purposes of this document, the terms and definitions given in ISO 5598 apply.

ISO and IEC maintain terminological databases for use in standardization at the following addresses:

- IEC Electropedia: available at <http://www.electropedia.org/>
- ISO Online browsing platform: available at <http://www.iso.org/obp>

4 Symbols

- a) A, B, X, Y, Z₁ and Z₂ identify ports the operational usage of which, in some cases, may be different from that given in the following examples:
- 1) A: inlet, service, return corresponding to the placing in the hydraulic circuit;
 - 2) B: inlet, service, return corresponding to the placing in the hydraulic circuit;
 - 3) X: pilot, inlet;
 - 4) Y: pilot, return;

- 5) Z_1 : supplementary pilot, inlet;
- 6) Z_2 : supplementary pilot, return;
- b) $F_1 \dots F_{12}$ identify threaded holes for fixing screws;
- c) G, G_1 and G_2 identify the location of pin holes;
- d) D identifies the fixing screw diameter;
- e) r_{\max} identifies the mounting surface edge radius;
- f) R_1 indicates the maximum radius at the bottom of d_1 .

The code system used in this document is defined in ISO 5783.

NOTE Size 15 and size 16 are not yet listed in ISO 5783.

5 Tolerances

The following requirements shall be applied to the sealing and chamfer surfaces, i.e. that area within the chain lines:

- surface roughness (see ISO 3601-2);
- surface roughness, R_z : as indicated on the figures according to ISO 1302 and ISO 4287;
- all non-specified surface finishes: R_z 63;
- surface roughness values are given in micrometres (μm);
- surface flatness: 0,01 mm over a distance of 100 mm (see ISO 3601-2).

The following tolerances shall be complied with along the x, y and z axes with respect to the origin:

- pin holes: $\pm 0,2$ mm;
- screw holes: $\pm 0,2$ mm;
- port holes: $\pm 0,2$ mm;
- general tolerances according to ISO 2768-1 for linear and angular dimensions without tolerances.

As for other dimensions, see [Figure 1](#) to [Figure 16](#).

6 Dimensions

6.1 Cavity dimensions for hydraulic slip-in cartridge valves with two main ports shall be selected from [Figure 1](#) to [Figure 16](#) and [Table 1](#) to [Table 16](#) as specified in [6.2](#) to [6.17](#).

6.2 Cavity dimensions for all types of valves, except main system pressure-relief valves, with main ports of 16 mm nominal diameter (size 06) (code 7368 - 06 - 1 - 1 - 16) are specified in [Table 1](#) and shown in [Figure 1](#).

6.3 Cavity dimensions for main system pressure-relief valves with main ports of 16 mm nominal diameter (size 06) (code 7368 - 06 - 2 - 1 - 16) are specified in [Table 2](#) and shown in [Figure 2](#).

6.4 Cavity dimensions for all types of valves, except main system pressure-relief valves, with main ports of 25 mm nominal diameter (size 08) (code 7368 - 08 - 3 - 1 - 16) are specified in [Table 3](#) and shown in [Figure 3](#).

6.5 Cavity dimensions for main system pressure-relief valves with main ports of 25 mm nominal diameter (size 08) (code 7368 - 08 - 4 - 1 - 16) are specified in [Table 4](#) and shown in [Figure 4](#).

6.6 Cavity dimensions for all types of valves, except main system pressure-relief valves, with main ports of 32 mm nominal diameter (size 09) (code 7368 - 09 - 5 - 1 - 16) are specified in [Table 5](#) and shown in [Figure 5](#).

6.7 Cavity dimensions for main system pressure-relief valves with main ports of 32 mm nominal diameter (size 09) (code 7368 - 09 - 6 - 1 - 16) are specified in [Table 6](#) and shown in [Figure 6](#).

6.8 Cavity dimensions for all types of valves, except main system pressure-relief valves, with main ports of 40 mm nominal diameter (size 10) (code 7368 - 10 - 7 - 1 - 16) are specified in [Table 7](#) and shown in [Figure 7](#).

6.9 Cavity dimensions for main system pressure-relief valves with main ports of 40 mm nominal diameter (size 10) (code 7368 - 10 - 8 - 1 - 16) are specified in [Table 8](#) and shown in [Figure 8](#).

6.10 Cavity dimensions for all types of valves, except main system pressure-relief valves, with main ports of 50 mm nominal diameter (size 11) (code 7368 - 11 - 9 - 1 - 16) are specified in [Table 9](#) and shown in [Figure 9](#).

6.11 Cavity dimensions for main system pressure-relief valves with main ports of 50 mm nominal diameter (size 11) (code 7368 - 11 - 10 - 1 - 16) are specified in [Table 10](#) and shown in [Figure 10](#).

6.12 Cavity dimensions for all types of valves, except main system pressure-relief valves, with main ports of 63 mm nominal diameter (size 12) (code 7368 - 12 - 11 - 1 - 16) are specified in [Table 11](#) and shown in [Figure 11](#).

6.13 Cavity dimensions for main system pressure-relief valves with main ports of 63 mm nominal diameter (size 12) (code 7368 - 12 - 12 - 1 - 16) are specified in [Table 12](#) and shown in [Figure 12](#).

6.14 Cavity dimensions for all types of valves, except main system pressure-relief valves, with main ports of 80 mm nominal diameter (size 13) (code 7368 - 13 - 13 - 1 - 16) are specified in [Table 13](#) and shown in [Figure 13](#).

6.15 Cavity dimensions for all types of valves, except main system pressure-relief valves, with main ports of 100 mm nominal diameter (size 14) (code 7368 - 14 - 14 - 1 - 16) are specified in [Table 14](#) and shown in [Figure 14](#).

6.16 Cavity dimensions for all types of valves, except main system pressure-relief valves, with main ports of 125 mm nominal diameter (size 15) (code 7368 - 15 - 15 - 1 - 16) are specified in [Table 15](#) and shown in [Figure 15](#).

6.17 Cavity dimensions for all types of valves, except main system pressure-relief valves, with main ports of 160 mm nominal diameter (size 16) (code 7368 - 16 - 16 - 1 - 16) are specified in [Table 16](#) and shown in [Figure 16](#).

7 Identification statement (Reference of this International Standard)

Use the following statement in test reports, catalogues and sales literature when electing to comply with this International Standard:

“Cavity dimensions conform to ISO 7368, *Hydraulic fluid power — Two-port slip-in cartridge valves — Cavities.*”

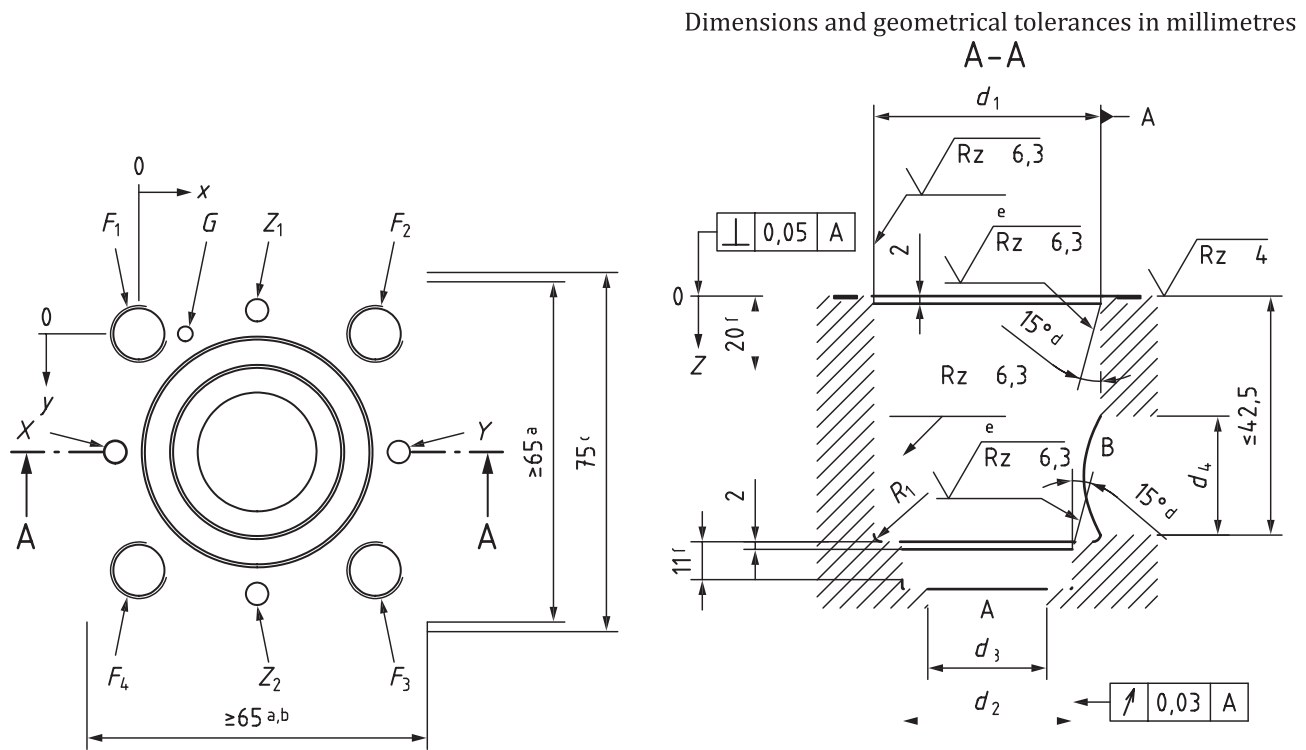

Key

- a The dimension specifying the area within the chain lines is the minimum dimension for mounting the cartridge valve cover. The corners of the square may be rounded to a maximum radius, r_{max} , equal to the thread diameter of the fixing screws. Along each axis, the fixing holes are at equal distances to the valve cover mounting surface edges.
- b Pilot valves and adjustment devices may exceed this dimension.
- c This dimension gives the minimum space required for a two-port hydraulic slip-in cartridge valve and its cover with this cavity. The dimension is also the minimum distance from centreline to centreline of two identical cavities on a manifold. The valve manufacturer’s attention is drawn to the fact that no part of the complete valve assembly shall exceed this dimension.
- d No burrs permitted in this area; the edges shall be rounded.
- e Visual examination.
- f Minimum length over which the specified surface finish shall apply.

Figure 1 — Cavity for two-port hydraulic slip-in cartridge valves of all types, except main system pressure-relief valves, with main ports of 16 mm nominal diameter (size 06) and square flange cover (code: 7368 - 06 - 1 - 1 - 16)

Table 1 — Cavity for two-port hydraulic slip-in cartridge valves of all types, except main system pressure-relief valves, with main ports of 16 mm nominal diameter (size 06) and square flange cover

Dimensions in millimetres

Axis	d_1^e	d_2^e	d_3^c	$d_4^{b,c}$	X^c	Y^c	Z_1^c	Z_2^c	F_1^a	F_2^a	F_3^a	F_4^a	$G^{d,e}$	R_1
	$\varnothing 32$ H7	$\varnothing 25$ H7	$\varnothing 16$ max.	$\varnothing 16$	$\varnothing 4$ max.	$\varnothing 4$ max.	$\varnothing 4$ max.	$\varnothing 4$ max.	M8	M8	M8	M8	$\varnothing 4$ H13	max. R 2
x	23	23	23	—	-2	48	23	23	0	46	46	0	12,5	—
y	23	23	23	—	23	23	-2	48	0	0	46	46	0	—
z	$43 \pm 0,2$	$56 + 0,1$	—	—	—	—	—	—	—	—	—	—	8 min.	—

a The minimum thread depth is 1,8 times the screw diameter, D . The recommended full thread depth is $2 \cdot D + 6$ mm to facilitate interchangeability of valves and to reduce the number of fixing screw lengths. However, sufficient distance from fixing hole to port B shall be respected. The recommended engagement of fixing screw thread for ferrous mounting is $1,25 \cdot D$.

b Suggested diameter of port B, but may be of any size located within the space between the dimensions indicated as 20 mm and 42,5 mm; port B is not necessarily machined and may be provided by casting.

c The depth and angle of the pilot ports and the main ports are determined by the graphical layout of the hydraulic circuit and by the location of the valves in the manifold.

d Blind hole to accommodate the locating pin on the valve cover.

e The depth of d_1 , d_2 and G are given in the tables as dimension z .

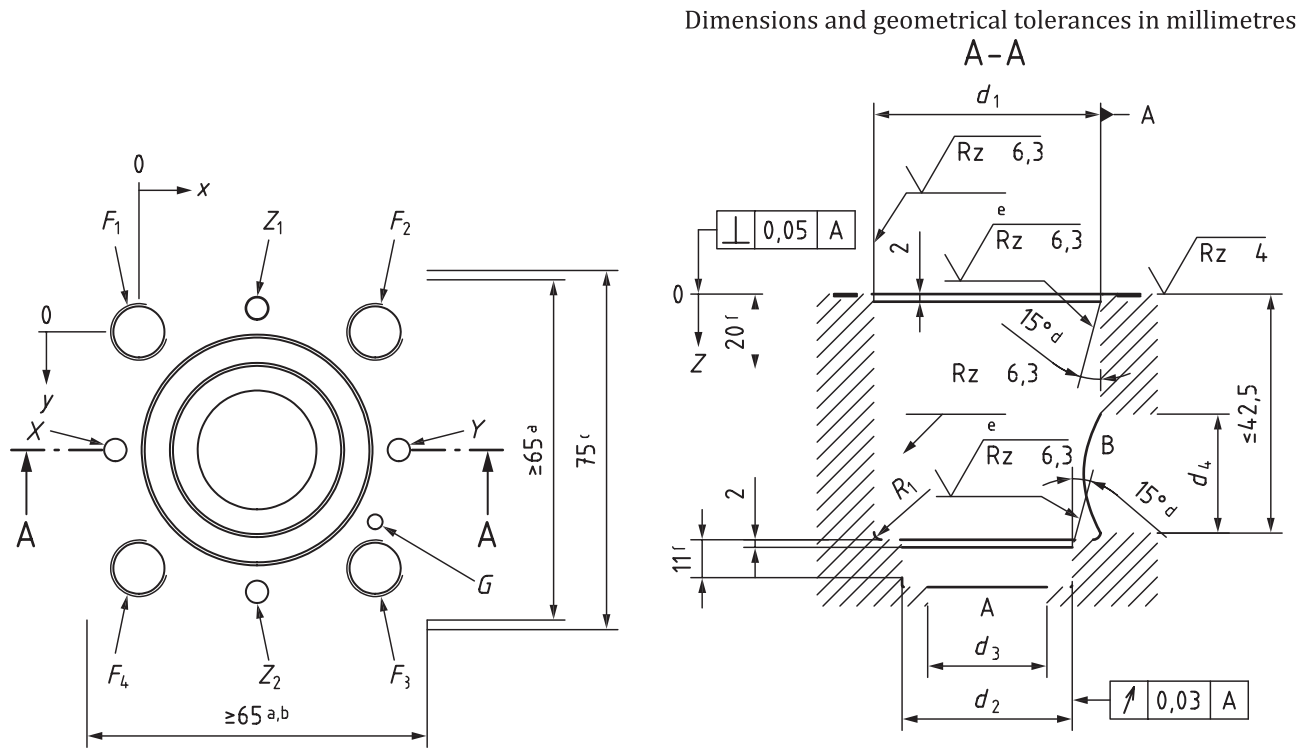

Key

- a The dimension specifying the area within the chain lines is the minimum dimension for mounting the cartridge valve cover. The corners of the square may be rounded to a maximum radius, r_{max} , equal to the thread diameter of the fixing screws. Along each axis, the fixing holes are at equal distances to the valve cover mounting surface edges.
- b Pilot valves and adjustment devices may exceed this dimension.
- c This dimension gives the minimum space required for a two-port hydraulic slip-in cartridge valve and its cover with this cavity. The dimension is also the minimum distance from centreline to centreline of two identical cavities on a manifold. The valve manufacturer’s attention is drawn to the fact that no part of the complete valve assembly shall exceed this dimension.
- d No burrs permitted in this area; the edges shall be rounded.
- e Visual examination.
- f Minimum length over which the specified surface finish shall apply.

Figure 2 — Cavity for two-port hydraulic slip-in cartridge main system pressure-relief valves with main ports of 16 mm nominal diameter (size 06) and square flange cover (code: 7368 - 06 - 2 - 1 - 16)

Table 2 — Cavity for two-port hydraulic slip-in cartridge main system pressure-relief valves with main ports of 16 mm nominal diameter (size 06) and square flange cover

Dimensions in millimetres

Axis	d_1^e	d_2^e	d_3^c	$d_4^{b,c}$	X^c	Y^c	Z_1^c	Z_2^c	F_1^a	F_2^a	F_3^a	F_4^a	$G^{d,e}$	R_1
	$\varnothing 32$ H7	$\varnothing 25$ H7	$\varnothing 16$ max.	$\varnothing 16$	$\varnothing 4$ max.	$\varnothing 4$ max.	$\varnothing 4$ max.	$\varnothing 4$ max.	M8	M8	M8	M8	$\varnothing 4$ H13	max. R 2
<i>x</i>	23	23	23	—	-2	48	23	23	0	46	46	0	46	—
<i>y</i>	23	23	23	—	23	23	-2	48	0	0	46	46	33,5	—
<i>z</i>	$43 \pm 0,2$	$56 + 0,1$	—	—	—	—	—	—	—	—	—	—	8 min.	—

a The minimum thread depth is 1,8 times the screw diameter, D . The recommended full thread depth is $2 \cdot D + 6$ mm to facilitate interchangeability of valves and to reduce the number of fixing screw lengths. However, sufficient distance from fixing hole to port B shall be respected. The recommended engagement of fixing screw thread for ferrous mounting is $1,25 \cdot D$.

b Suggested diameter of port B, but may be of any size located within the space between the dimensions indicated as 20 mm and 42,5 mm; port B is not necessarily machined and may be provided by casting.

c The depth and angle of the pilot ports and the main ports are determined by the graphical layout of the hydraulic circuit and by the location of the valves in the manifold.

d Blind hole to accommodate the locating pin on the valve cover.

e The depth of d_1 , d_2 and G are given in the tables as dimension z .

Dimensions and geometrical tolerances in millimetres

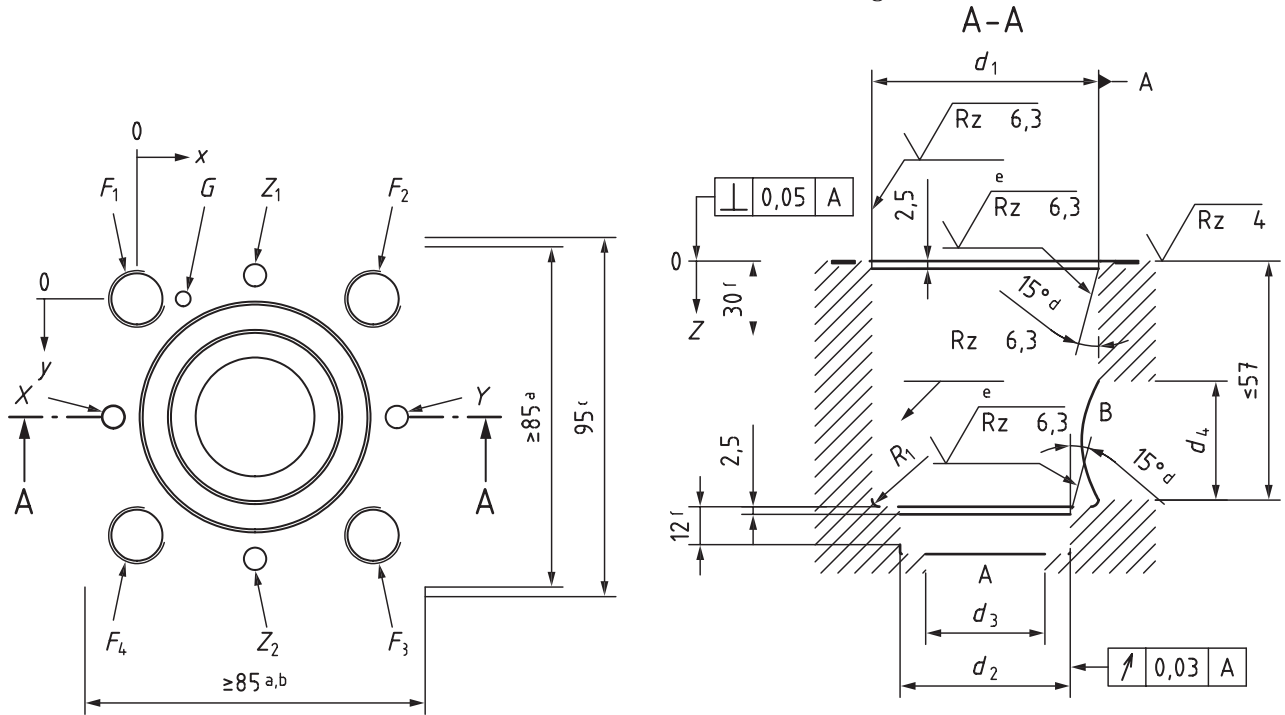

Key

- a The dimension specifying the area within the chain lines is the minimum dimension for mounting the cartridge valve cover. The corners of the square may be rounded to a maximum radius, r_{max} , equal to the thread diameter of the fixing screws. Along each axis, the fixing holes are at equal distances to the valve cover mounting surface edges.
- b Pilot valves and adjustment devices may exceed this dimension.
- c This dimension gives the minimum space required for a two-port hydraulic slip-in cartridge valve and its cover with this cavity. The dimension is also the minimum distance from centreline to centreline of two identical cavities on a manifold. The valve manufacturer’s attention is drawn to the fact that no part of the complete valve assembly shall exceed this dimension.
- d No burrs permitted in this area; the edges shall be rounded.
- e Visual examination.
- f Minimum length over which the specified surface finish shall apply.

Figure 3 — Cavity for two-port hydraulic slip-in cartridge valves of all types, except main system pressure-relief valves, with main ports of 25 mm nominal diameter (size 08) and square flange cover (code: 7368 - 08 - 3 - 1 - 16)

Table 3 — Cavity for two-port hydraulic slip-in cartridge valves of all types, except main system pressure-relief valves, with main ports of 25 mm nominal diameter (size 08) and square flange cover

Dimensions in millimetres

Axis	d_1^e	d_2^e	d_3^c	$d_4^{b,c}$	X^c	Y^c	Z_1^c	Z_2^c	F_1^a	F_2^a	F_3^a	F_4^a	$G^{d,e}$	R_1
	∅ 45 H7	∅ 34 H7	∅ 25 max.	∅ 25	∅ 6 max.	∅ 6 max.	∅ 6 max.	∅ 6 max.	M12	M12	M12	M12	∅ 6 H13	max. R 2
<i>x</i>	29	29	29	—	-4	62	29	29	0	58	58	0	13	—
<i>y</i>	29	29	29	—	29	29	-4	62	0	0	58	58	0	—
<i>z</i>	58 ± 0,2	72 + 0,1	—	—	—	—	—	—	—	—	—	—	8 min.	—

- ^a The minimum thread depth is 1,8 times the screw diameter, D . The recommended full thread depth is $2 \cdot D + 6$ mm to facilitate interchangeability of valves and to reduce the number of fixing screw lengths. However, sufficient distance from fixing hole to port B shall be respected. The recommended engagement of fixing screw thread for ferrous mounting is $1,25 \cdot D$.
- ^b Suggested diameter of port B, but may be of any size located within the space between the dimensions indicated as 30 mm and 57 mm; port B is not necessarily machined and may be provided by casting.
- ^c The depth and angle of the pilot ports and the main ports are determined by the graphical layout of the hydraulic circuit and by the location of the valves in the manifold.
- ^d Blind hole to accommodate the locating pin on the valve cover.
- ^e The depth of d_1 , d_2 and G are given in the tables as dimension z .

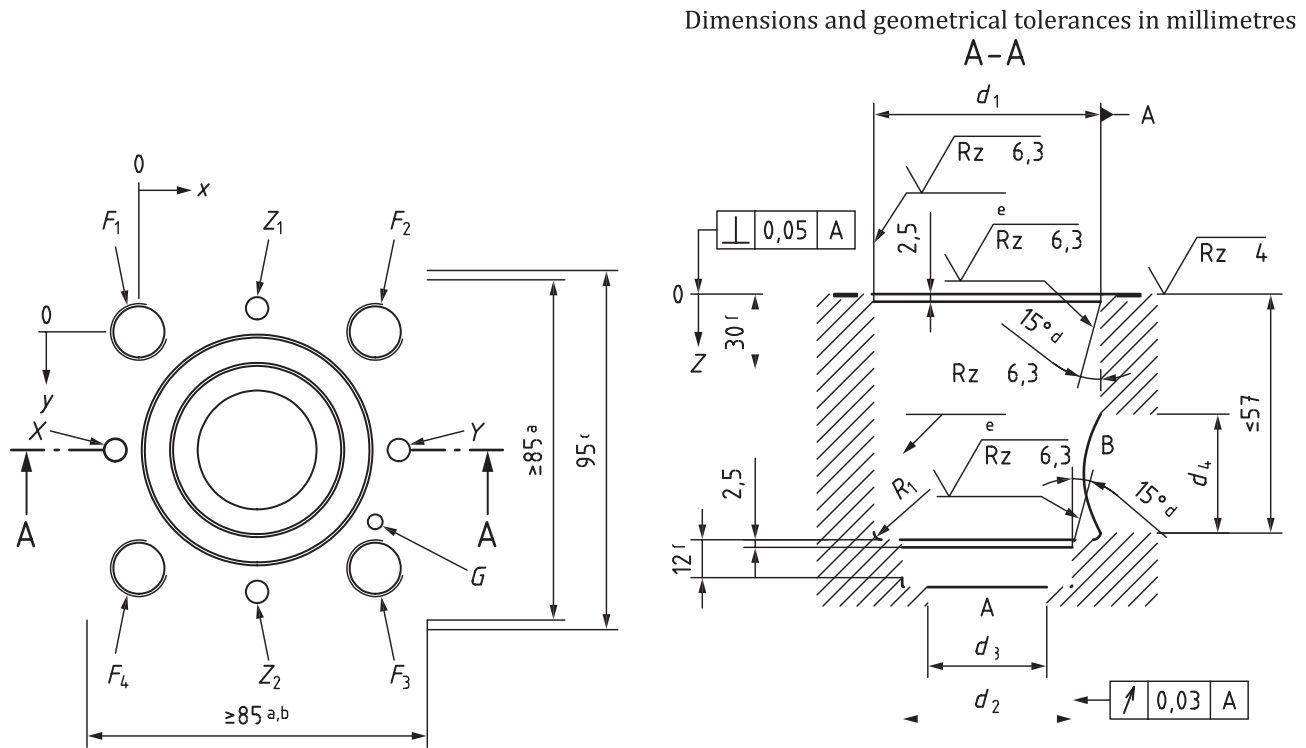

Key

- a The dimension specifying the area within the chain lines is the minimum dimension for mounting the cartridge valve cover. The corners of the square may be rounded to a maximum radius, r_{max} , equal to the thread diameter of the fixing screws. Along each axis, the fixing holes are at equal distances to the valve cover mounting surface edges.
- b Pilot valves and adjustment devices may exceed this dimension.
- c This dimension gives the minimum space required for a two-port hydraulic slip-in cartridge valve and its cover with this cavity. The dimension is also the minimum distance from centreline to centreline of two identical cavities on a manifold. The valve manufacturer's attention is drawn to the fact that no part of the complete valve assembly shall exceed this dimension.
- d No burrs permitted in this area; the edges shall be rounded.
- e Visual examination.
- f Minimum length over which the specified surface finish shall apply.

Figure 4 — Cavity for two-port hydraulic slip-in cartridge main system pressure-relief valves with main ports of 25 mm nominal diameter (size 08) and square flange cover (code: 7368 - 08 - 4 - 1 - 16)

Table 4 — Cavity for two-port hydraulic slip-in cartridge main system pressure-relief valves with main ports of 25 mm nominal diameter (size 08) and square flange cover

Dimensions in millimetres

Axis	d_1^e	d_2^e	d_3^c	$d_4^{b,c}$	X^c	Y^c	Z_1^c	Z_2^c	F_1^a	F_2^a	F_3^a	F_4^a	$G^{d,e}$	R_1
	$\varnothing 45$ H7	$\varnothing 34$ H7	$\varnothing 25$ max.	$\varnothing 25$	$\varnothing 6$ max.	$\varnothing 6$ max.	$\varnothing 6$ max.	$\varnothing 6$ max.	M12	M12	M12	M12	$\varnothing 6$ H13	max. R 2
x	29	29	29	—	-4	62	29	29	0	58	58	0	58	—
y	29	29	29	—	29	29	-4	62	0	0	58	58	45	—
z	$58 \pm 0,2$	$72 + 0,1$	—	—	—	—	—	—	—	—	—	—	8 min.	—

a The minimum thread depth is 1,8 times the screw diameter, D . The recommended full thread depth is $2 \cdot D + 6$ mm to facilitate interchangeability of valves and to reduce the number of fixing screw lengths. However, sufficient distance from fixing hole to port B shall be respected. The recommended engagement of fixing screw thread for ferrous mounting is $1,25 \cdot D$.

b Suggested diameter of port B, but may be of any size located within the space between the dimensions indicated as 30 mm and 57 mm; port B is not necessarily machined and may be provided by casting.

c The depth and angle of the pilot ports and the main ports are determined by the graphical layout of the hydraulic circuit and by the location of the valves in the manifold.

d Blind hole to accommodate the locating pin on the valve cover.

e The depth of d_1 , d_2 and G are given in the tables as dimension z .

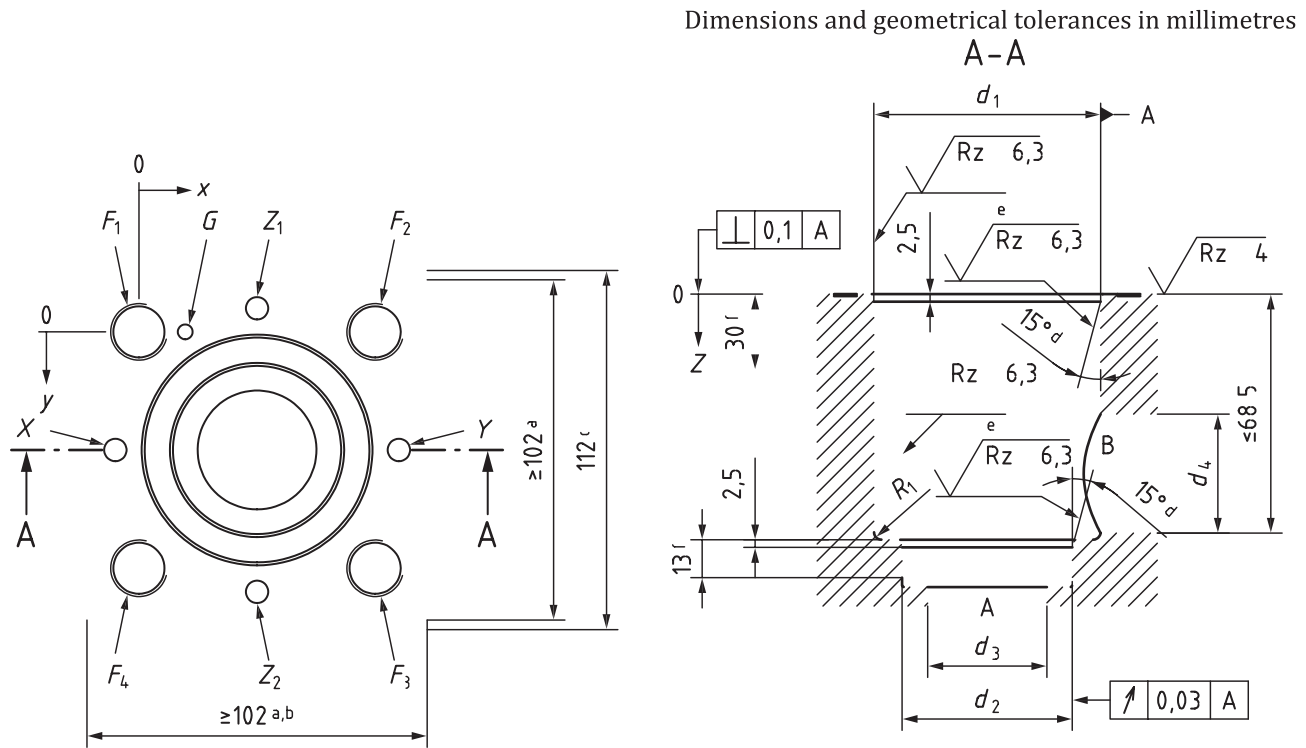

Key

- a The dimension specifying the area within the chain lines is the minimum dimension for mounting the cartridge valve cover. The corners of the square may be rounded to a maximum radius, r_{max} , equal to the thread diameter of the fixing screws. Along each axis, the fixing holes are at equal distances to the valve cover mounting surface edges.
- b Pilot valves and adjustment devices may exceed this dimension.
- c This dimension gives the minimum space required for a two-port hydraulic slip-in cartridge valve and its cover with this cavity. The dimension is also the minimum distance from centreline to centreline of two identical cavities on a manifold. The valve manufacturer's attention is drawn to the fact that no part of the complete valve assembly shall exceed this dimension.
- d No burrs permitted in this area; the edges shall be rounded.
- e Visual examination.
- f Minimum length over which the specified surface finish shall apply.

Figure 5 — Cavity for two-port hydraulic slip-in cartridge valves of all types, except main system pressure-relief valves, with main ports of 32 mm nominal diameter (size 09) and square flange cover (code: 7368 - 09 - 5 - 1 - 16)

Table 5 — Cavity for two-port hydraulic slip-in cartridge valves of all types, except main system pressure-relief valves, with main ports of 32 mm nominal diameter (size 09) and square flange cover

Dimensions in millimetres

Axis	d_1^e	d_2^e	d_3^c	$d_4^{b,c}$	X^c	Y^c	Z_1^c	Z_2^c	F_1^a	F_2^a	F_3^a	F_4^a	$G^{d,e}$	R_1
	$\varnothing 60$ H7	$\varnothing 45$ H7	$\varnothing 32$ max.	$\varnothing 32$	$\varnothing 8$ max.	$\varnothing 8$ max.	$\varnothing 8$ max.	$\varnothing 8$ max.	M16	M16	M16	M16	$\varnothing 6$ H13	max. R 2
x	35	35	35	—	-6	76	35	35	0	70	70	0	18	—
y	35	35	35	—	35	35	-6	76	0	0	70	70	0	—
z	$70 \pm 0,2$	$85 + 0,1$	—	—	—	—	—	—	—	—	—	—	8 min.	—

a The minimum thread depth is 1,8 times the screw diameter, D . The recommended full thread depth is $2 \cdot D + 6$ mm to facilitate interchangeability of valves and to reduce the number of fixing screw lengths. However, sufficient distance from fixing hole to port B shall be respected. The recommended engagement of fixing screw thread for ferrous mounting is $1,25 \cdot D$.

b Suggested diameter of port B, but may be of any size located within the space between the dimensions indicated as 30 mm and 68,5 mm; port B is not necessarily machined and may be provided by casting.

c The depth and angle of the pilot ports and the main ports are determined by the graphical layout of the hydraulic circuit and by the location of the valves in the manifold.

d Blind hole to accommodate the locating pin on the valve cover.

e The depth of d_1 , d_2 and G are given in the tables as dimension z .

Dimensions and geometrical tolerances in millimetres

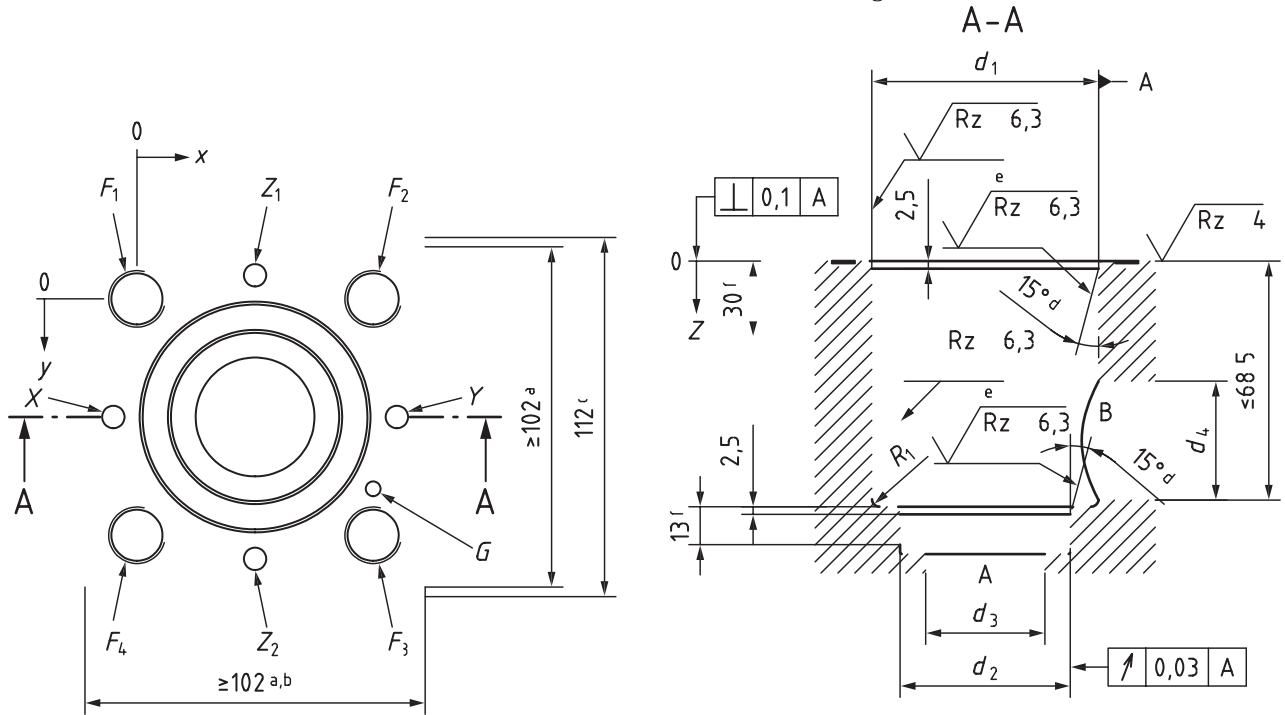

Key

- a The dimension specifying the area within the chain lines is the minimum dimension for mounting the cartridge valve cover. The corners of the square may be rounded to a maximum radius, r_{max} , equal to the thread diameter of the fixing screws. Along each axis, the fixing holes are at equal distances to the valve cover mounting surface edges.
- b Pilot valves and adjustment devices may exceed this dimension.
- c This dimension gives the minimum space required for a two-port hydraulic slip-in cartridge valve and its cover with this cavity. The dimension is also the minimum distance from centreline to centreline of two identical cavities on a manifold. The valve manufacturer's attention is drawn to the fact that no part of the complete valve assembly shall exceed this dimension.
- d No burrs permitted in this area; the edges shall be rounded.
- e Visual examination.
- f Minimum length over which the specified surface finish shall apply.

Figure 6 — Cavity for two-port hydraulic slip-in cartridge main system pressure-relief valves with main ports of 32 mm nominal diameter (size 09) and square flange cover (code: 7368 - 09 - 6 - 1 - 16)

Table 6 — Cavity for two-port hydraulic slip-in cartridge main system pressure-relief valves with main ports of 32 mm nominal diameter (size 09) and square flange cover

Dimensions in millimetres

Axis	d_1^e	d_2^e	d_3^c	$d_4^{b,c}$	X^c	Y^c	Z_1^c	Z_2^c	F_1^a	F_2^a	F_3^a	F_4^a	$G^{d,e}$	R_1
	$\varnothing 60$ H7	$\varnothing 45$ H7	$\varnothing 32$ max.	$\varnothing 32$	$\varnothing 8$ max.	$\varnothing 8$ max.	$\varnothing 8$ max.	$\varnothing 8$ max.	M16	M16	M16	M16	$\varnothing 6$ H13	max. R 2
x	35	35	35	—	-6	76	35	35	0	70	70	0	70	—
y	35	35	35	—	35	35	-6	76	0	0	70	70	52	—
z	$70 \pm 0,3$	$85 + 0,1$	—	—	—	—	—	—	—	—	—	—	8 min.	—

a The minimum thread depth is 1,8 times the screw diameter, D . The recommended full thread depth is $2 \cdot D + 6$ mm to facilitate interchangeability of valves and to reduce the number of fixing screw lengths. However, sufficient distance from fixing hole to port B shall be respected. The recommended engagement of fixing screw thread for ferrous mounting is $1,25 \cdot D$.

b Suggested diameter of port B, but may be of any size located within the space between the dimensions indicated as 30 mm and 68,5 mm; port B is not necessarily machined and may be provided by casting.

c The depth and angle of the pilot ports and the main ports are determined by the graphical layout of the hydraulic circuit and by the location of the valves in the manifold.

d Blind hole to accommodate the locating pin on the valve cover.

e The depth of d_1 , d_2 and G are given in the tables as dimension z .

Dimensions and geometrical tolerances in millimetres

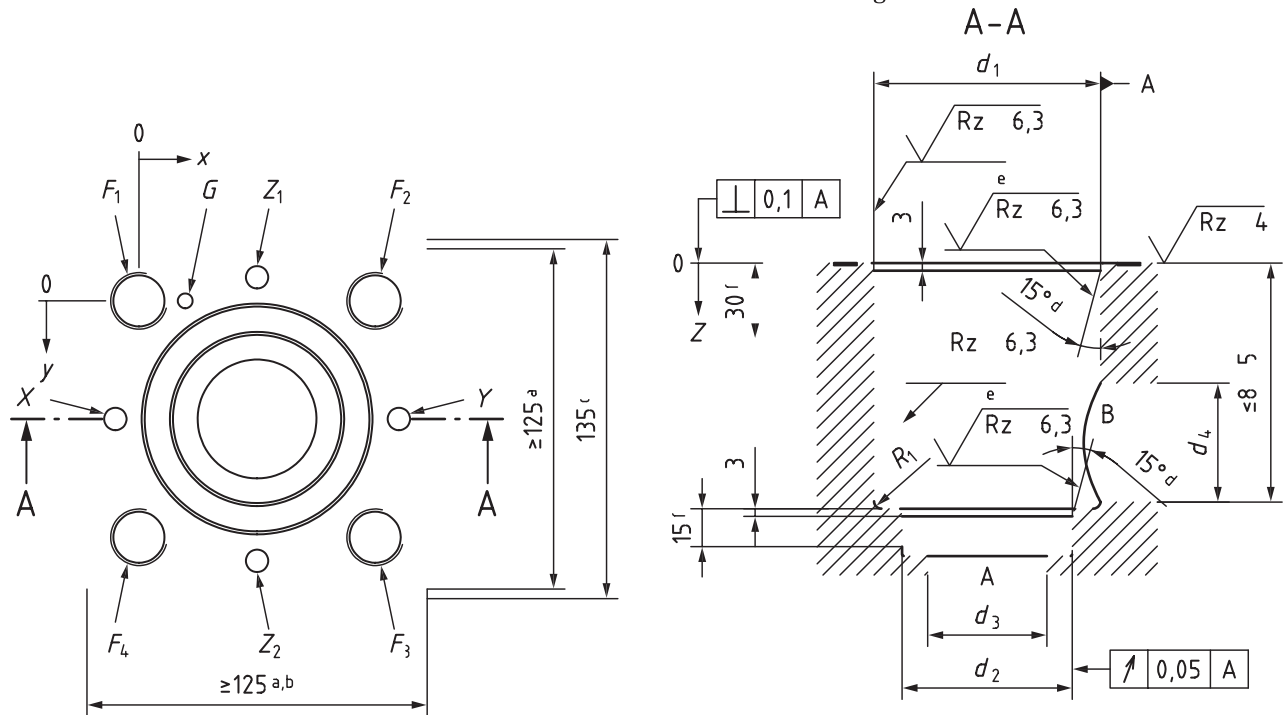

Key

- a The dimension specifying the area within the chain lines is the minimum dimension for mounting the cartridge valve cover. The corners of the square may be rounded to a maximum radius, r_{max} , equal to the thread diameter of the fixing screws. Along each axis, the fixing holes are at equal distances to the valve cover mounting surface edges.
- b Pilot valves and adjustment devices may exceed this dimension.
- c This dimension gives the minimum space required for a two-port hydraulic slip-in cartridge valve and its cover with this cavity. The dimension is also the minimum distance from centreline to centreline of two identical cavities on a manifold. The valve manufacturer's attention is drawn to the fact that no part of the complete valve assembly shall exceed this dimension.
- d No burrs permitted in this area; the edges shall be rounded.
- e Visual examination.
- f Minimum length over which the specified surface finish shall apply.

Figure 7 — Cavity for two-port hydraulic slip-in cartridge valves of all types, except main system pressure-relief valves, with main ports of 40 mm nominal diameter (size 10) and square flange cover (code: 7368 - 10 - 7 - 1 - 16)

Table 7 — Cavity for two-port hydraulic slip-in cartridge valves of all types, except main system pressure-relief valves, with main ports of 40 mm nominal diameter (size 10) and square flange cover

Dimensions in millimetres

Axis	d_1^e	d_2^e	d_3^c	$d_4^{b,c}$	X^c	Y^c	Z_1^c	Z_2^c	F_1^a	F_2^a	F_3^a	F_4^a	$G^{d,e}$	R_1
	$\varnothing 75$ H7	$\varnothing 55$ H7	$\varnothing 40$ max.	$\varnothing 40$	$\varnothing 10$ max.	$\varnothing 10$ max.	$\varnothing 10$ max.	$\varnothing 10$ max.	M20	M20	M20	M20	$\varnothing 6$ H13	max. R 4
x	42,5	42,5	42,5	—	-7,5	92,5	42,5	42,5	0	85	85	0	19,5	—
y	42,5	42,5	42,5	—	42,5	42,5	-7,5	92,5	0	0	85	85	0	—
z	$87 \pm 0,3$	$105 + 0,1$	—	—	—	—	—	—	—	—	—	—	8 min.	—

- ^a The minimum thread depth is 1,8 times the screw diameter, D . The recommended full thread depth is $2 \cdot D + 6$ mm to facilitate interchangeability of valves and to reduce the number of fixing screw lengths. However, sufficient distance from fixing hole to port B shall be respected. The recommended engagement of fixing screw thread for ferrous mounting is $1,25 \cdot D$.
- ^b Suggested diameter of port B, but may be of any size located within the space between the dimensions indicated as 30 mm and 84,5 mm; port B is not necessarily machined and may be provided by casting.
- ^c The depth and angle of the pilot ports and the main ports are determined by the graphical layout of the hydraulic circuit and by the location of the valves in the manifold.
- ^d Blind hole to accommodate the locating pin on the valve cover.
- ^e The depth of d_1 , d_2 and G are given in the tables as dimension z .

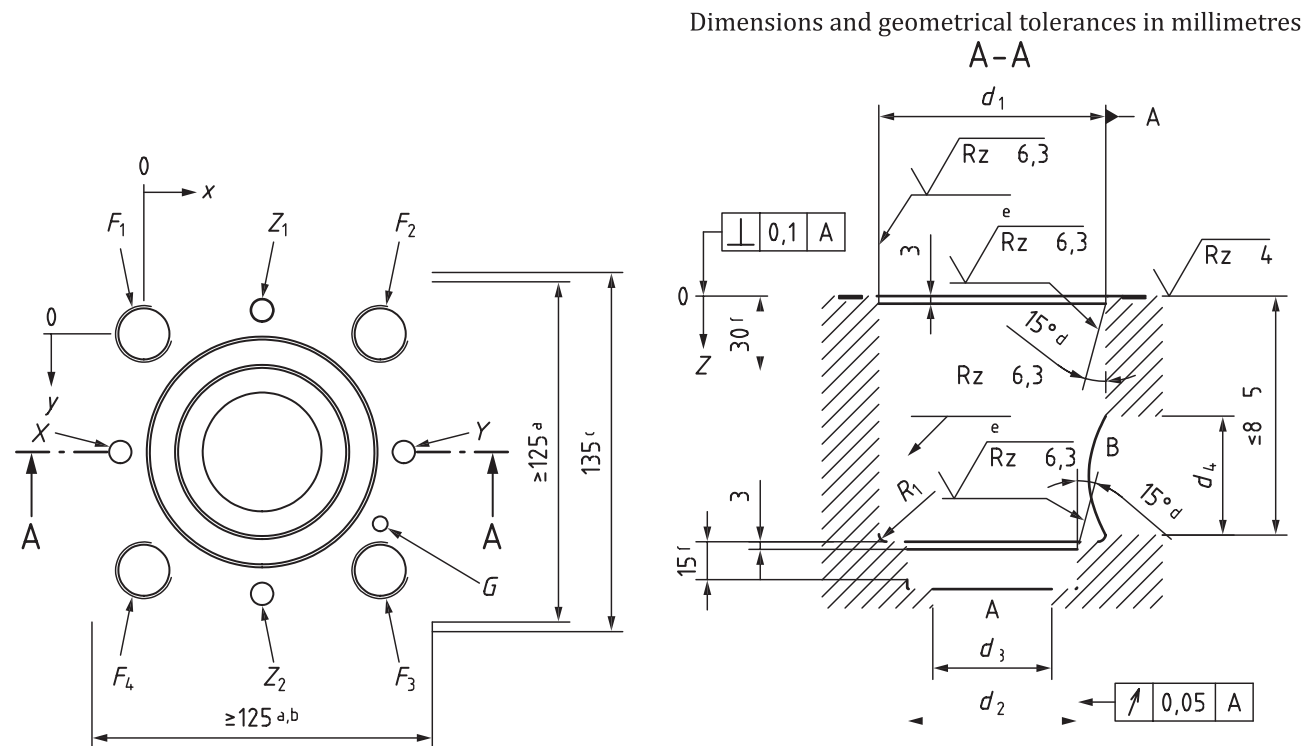

- Key**
- a The dimension specifying the area within the chain lines is the minimum dimension for mounting the cartridge valve cover. The corners of the square may be rounded to a maximum radius, r_{max} , equal to the thread diameter of the fixing screws. Along each axis, the fixing holes are at equal distances to the valve cover mounting surface edges.
 - b Pilot valves and adjustment devices may exceed this dimension.
 - c This dimension gives the minimum space required for a two-port hydraulic slip-in cartridge valve and its cover with this cavity. The dimension is also the minimum distance from centreline to centreline of two identical cavities on a manifold. The valve manufacturer's attention is drawn to the fact that no part of the complete valve assembly shall exceed this dimension.
 - d No burrs permitted in this area; the edges shall be rounded.
 - e Visual examination.
 - f Minimum length over which the specified surface finish shall apply.

Figure 8 — Cavity for two-port hydraulic slip-in cartridge main system pressure-relief valves with main ports of 40 mm nominal diameter (size 10) and square flange cover (code: 7368 - 10 - 8 - 1 - 16)

Table 8 — Cavity for two-port hydraulic slip-in cartridge main system pressure-relief valves with main ports of 40 mm nominal diameter (size 10) and square flange cover

Dimensions in millimetres

Axis	d_1^e	d_2^e	d_3^c	$d_4^{b,c}$	X^c	Y^c	Z_1^c	Z_2^c	F_1^a	F_2^a	F_3^a	F_4^a	$G^{d,e}$	R_1
	$\varnothing 75$ H7	$\varnothing 55$ H7	$\varnothing 40$ max.	$\varnothing 40$	$\varnothing 10$ max.	$\varnothing 10$ max.	$\varnothing 10$ max.	$\varnothing 10$ max.	M20	M20	M20	M20	$\varnothing 6$ H13	max. R 4
x	42,5	42,5	42,5	—	-7,5	92,5	42,5	42,5	0	85	85	0	85	—
y	42,5	42,5	42,5	—	42,5	42,5	-7,5	92,5	0	0	85	85	65,5	—
z	$87 \pm 0,3$	$105 + 0,1$	—	—	—	—	—	—	—	—	—	—	8 min.	—

^a The minimum thread depth is 1,8 times the screw diameter, D . The recommended full thread depth is $2 \cdot D + 6$ mm to facilitate interchangeability of valves and to reduce the number of fixing screw lengths. However, sufficient distance from fixing hole to port B shall be respected. The recommended engagement of fixing screw thread for ferrous mounting is $1,25 \cdot D$.

^b Suggested diameter of port B, but may be of any size located within the space between the dimensions indicated as 30 mm and 84,5 mm; port B is not necessarily machined and may be provided by casting.

^c The depth and angle of the pilot ports and the main ports are determined by the graphical layout of the hydraulic circuit and by the location of the valves in the manifold.

^d Blind hole to accommodate the locating pin on the valve cover.

^e The depth of d_1 , d_2 and G are given in the tables as dimension z .

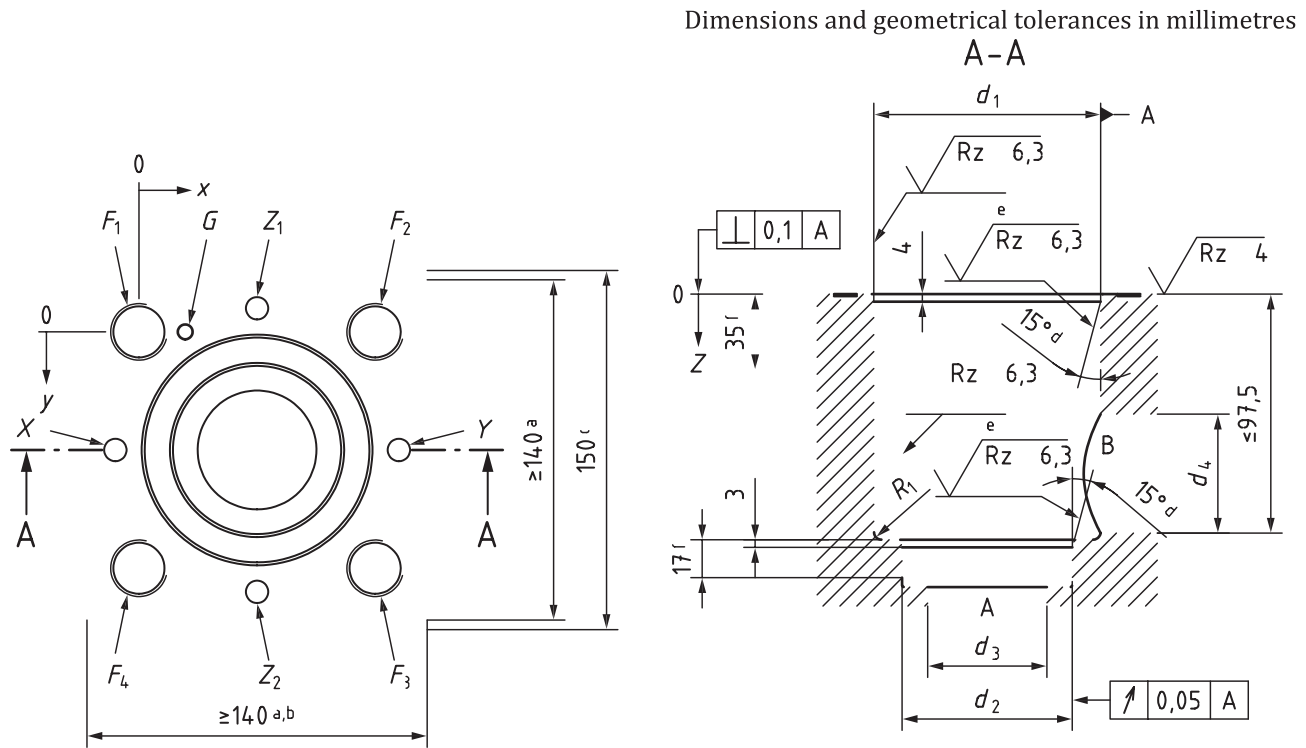

Key

- a The dimension specifying the area within the chain lines is the minimum dimension for mounting the cartridge valve cover. The corners of the square may be rounded to a maximum radius, r_{max} , equal to the thread diameter of the fixing screws. Along each axis, the fixing holes are at equal distances to the valve cover mounting surface edges.
- b Pilot valves and adjustment devices may exceed this dimension.
- c This dimension gives the minimum space required for a two-port hydraulic slip-in cartridge valve and its cover with this cavity. The dimension is also the minimum distance from centreline to centreline of two identical cavities on a manifold. The valve manufacturer’s attention is drawn to the fact that no part of the complete valve assembly shall exceed this dimension.
- d No burrs permitted in this area; the edges shall be rounded.
- e Visual examination.
- f Minimum length over which the specified surface finish shall apply.

Figure 9 — Cavity for two-port hydraulic slip-in cartridge valves of all types, except main system pressure-relief valves, with main ports of 50 mm nominal diameter (size 11) and square flange cover (code: 7368 - 11 - 9 - 1 - 16)

Table 9 — Cavity for two-port hydraulic slip-in cartridge valves of all types, except main system pressure-relief valves, with main ports of 50 mm nominal diameter (size 11) and square flange cover

Dimensions in millimetres

Axis	d_1^e	d_2^e	d_3^c	$d_4^{b,c}$	X^c	Y^c	Z_1^c	Z_2^c	F_1^a	F_2^a	F_3^a	F_4^a	$G^{d,e}$	R_1
	$\varnothing 90$ H7	$\varnothing 68$ H7	$\varnothing 50$ max.	$\varnothing 50$	$\varnothing 10$ max.	$\varnothing 10$ max.	$\varnothing 10$ max.	$\varnothing 10$ max.	M20	M20	M20	M20	$\varnothing 8$ H13	max. R 4
x	50	50	50	—	-8	108	50	50	0	100	100	0	20	—
y	50	50	50	—	50	50	-8	108	0	0	100	100	0	—
z	$100 \pm 0,3$	$122 + 0,1$	—	—	—	—	—	—	—	—	—	—	8 min.	—

- a The minimum thread depth is 1,8 times the screw diameter, D . The recommended full thread depth is $2 \cdot D + 6$ mm to facilitate interchangeability of valves and to reduce the number of fixing screw lengths. However, sufficient distance from fixing hole to port B shall be respected. The recommended engagement of fixing screw thread for ferrous mounting is $1,25 \cdot D$.
- b Suggested diameter of port B, but may be of any size located within the space between the dimensions indicated as 35 mm and 97,5 mm; port B is not necessarily machined and may be provided by casting.
- c The depth and angle of the pilot ports and the main ports are determined by the graphical layout of the hydraulic circuit and by the location of the valves in the manifold.
- d Blind hole to accommodate the locating pin on the valve cover.
- e The depth of d_1 , d_2 and G are given in the tables as dimension z .

Dimensions and geometrical tolerances in millimetres

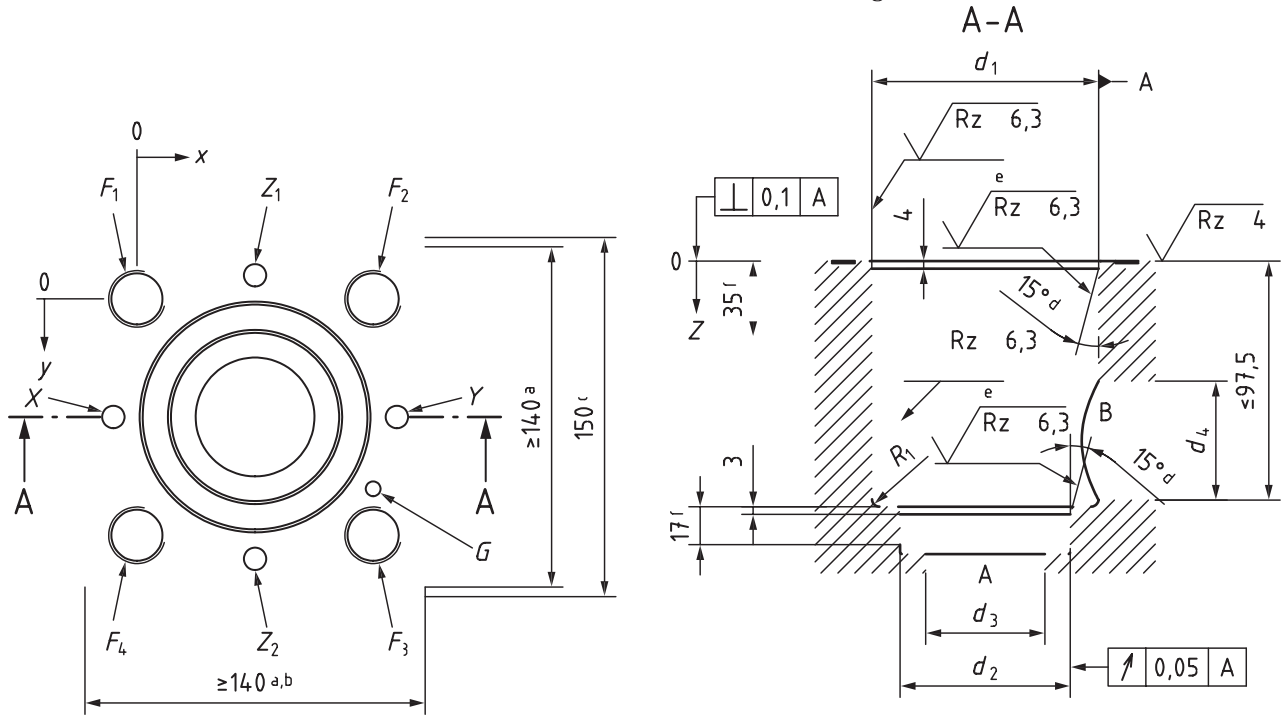

Key

- a The dimension specifying the area within the chain lines is the minimum dimension for mounting the cartridge valve cover. The corners of the square may be rounded to a maximum radius, r_{max} , equal to the thread diameter of the fixing screws. Along each axis, the fixing holes are at equal distances to the valve cover mounting surface edges.
- b Pilot valves and adjustment devices may exceed this dimension.
- c This dimension gives the minimum space required for a two-port hydraulic slip-in cartridge valve and its cover with this cavity. The dimension is also the minimum distance from centreline to centreline of two identical cavities on a manifold. The valve manufacturer's attention is drawn to the fact that no part of the complete valve assembly shall exceed this dimension.
- d No burrs permitted in this area; the edges shall be rounded.
- e Visual examination.
- f Minimum length over which the specified surface finish shall apply.

Figure 10 — Cavity for two-port hydraulic slip-in cartridge main system pressure-relief valves with main ports of 50 mm nominal diameter (size 11) and square flange cover (code: 7368 - 11 - 10 - 1 - 16)

Table 10 — Cavity for two-port hydraulic slip-in cartridge main system pressure-relief valves with main ports of 50 mm nominal diameter (size 11) and square flange cover

Dimensions in millimetres

Axis	d_1^e	d_2^e	d_3^c	$d_4^{b,c}$	X^c	Y^c	Z_1^c	Z_2^c	F_1^a	F_2^a	F_3^a	F_4^a	$G^{d,e}$	R_1
	$\varnothing 90$ H7	$\varnothing 68$ H7	$\varnothing 50$ max.	$\varnothing 50$	$\varnothing 10$ max.	$\varnothing 10$ max.	$\varnothing 10$ max.	$\varnothing 10$ max.	M20	M20	M20	M20	$\varnothing 8$ H13	max. R 4
x	50	50	50	—	-8	108	50	50	0	100	100	0	100	—
y	50	50	50	—	50	50	-8	108	0	0	100	100	80	—
z	$100 \pm 0,3$	$122 + 0,1$	—	—	—	—	—	—	—	—	—	—	8 min.	—

- a The minimum thread depth is 1,8 times the screw diameter, D . The recommended full thread depth is $2 \cdot D + 6$ mm to facilitate interchangeability of valves and to reduce the number of fixing screw lengths. However, sufficient distance from fixing hole to port B shall be respected. The recommended engagement of fixing screw thread for ferrous mounting is $1,25 \cdot D$.
- b Suggested diameter of port B, but may be of any size located within the space between the dimensions indicated as 35 mm and 97,5 mm; port B is not necessarily machined and may be provided by casting.
- c The depth and angle of the pilot ports and the main ports are determined by the graphical layout of the hydraulic circuit and by the location of the valves in the manifold.
- d Blind hole to accommodate the locating pin on the valve cover.
- e The depth of d_1 , d_2 and G are given in the tables as dimension z .

Dimensions and geometrical tolerances in millimetres

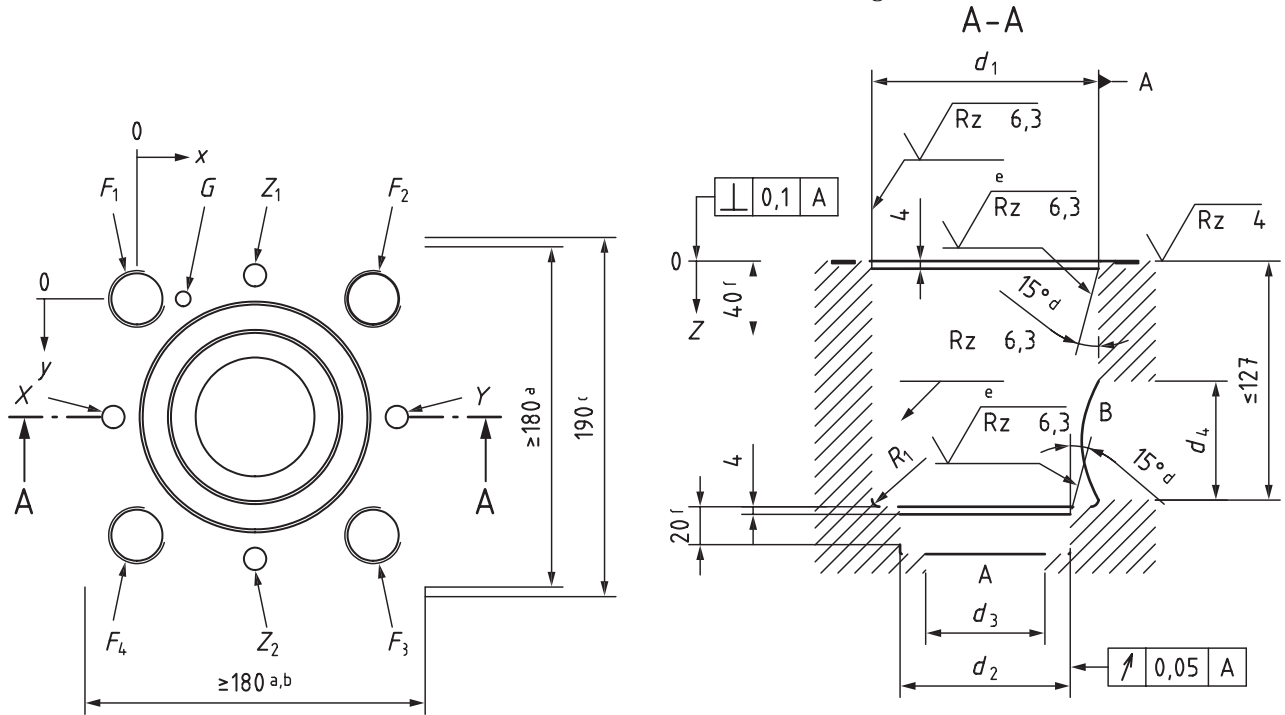

Key

- a The dimension specifying the area within the chain lines is the minimum dimension for mounting the cartridge valve cover. The corners of the square may be rounded to a maximum radius, r_{max} , equal to the thread diameter of the fixing screws. Along each axis, the fixing holes are at equal distances to the valve cover mounting surface edges.
- b Pilot valves and adjustment devices may exceed this dimension.
- c This dimension gives the minimum space required for a two-port hydraulic slip-in cartridge valve and its cover with this cavity. The dimension is also the minimum distance from centreline to centreline of two identical cavities on a manifold. The valve manufacturer’s attention is drawn to the fact that no part of the complete valve assembly shall exceed this dimension
- d No burrs permitted in this area; the edges shall be rounded.
- e Visual examination.
- f Minimum length over which the specified surface finish shall apply.

Figure 11 — Cavity for two-port hydraulic slip-in cartridge valves of all types, except main system pressure-relief valves, with main ports of 63 mm nominal diameter (size 12) and square flange cover (code: 7368 - 12 - 11 - 1 - 16)

Table 11 — Cavity for two-port hydraulic slip-in cartridge valves of all types, except main system pressure-relief valves, with main ports of 63 mm nominal diameter (size 12) and square flange cover

Dimensions in millimetres

Axis	d_1^e	d_2^e	d_3^c	$d_4^{b,c}$	X^c	Y^c	Z_1^c	Z_2^c	F_1^a	F_2^a	F_3^a	F_4^a	$G^{d,e}$	R_1
	∅ 120 H7	∅ 90 H7	∅ 63 max.	∅ 63	∅ 12 max.	∅ 12 max.	∅ 12 max.	∅ 12 max.	M30	M30	M30	M30	∅ 8 H13	max. R 4
x	62,5	62,5	62,5	—	-12,5	137,5	62,5	62,5	0	125	125	0	24,5	—
y	62,5	62,5	62,5	—	62,5	62,5	-12,5	137,5	0	0	125	125	0	—
z	130 ± 0,3	155 + 0,1	—	—	—	—	—	—	—	—	—	—	8 min.	—

a The minimum thread depth is 1,8 times the screw diameter, D . The recommended full thread depth is $2 \cdot D + 6$ mm to facilitate interchangeability of valves and to reduce the number of fixing screw lengths. However, sufficient distance from fixing hole to port B shall be respected. The recommended engagement of fixing screw thread for ferrous mounting is $1,25 \cdot D$.

b Suggested diameter of port B, but may be of any size located within the space between the dimensions indicated as 40 mm and 127 mm; port B is not necessarily machined and may be provided by casting.

c The depth and angle of the pilot ports and the main ports are determined by the graphical layout of the hydraulic circuit and by the location of the valves in the manifold.

d Blind hole to accommodate the locating pin on the valve cover.

e The depth of d_1 , d_2 and G are given in the tables as dimension z .

Dimensions and geometrical tolerances in millimetres

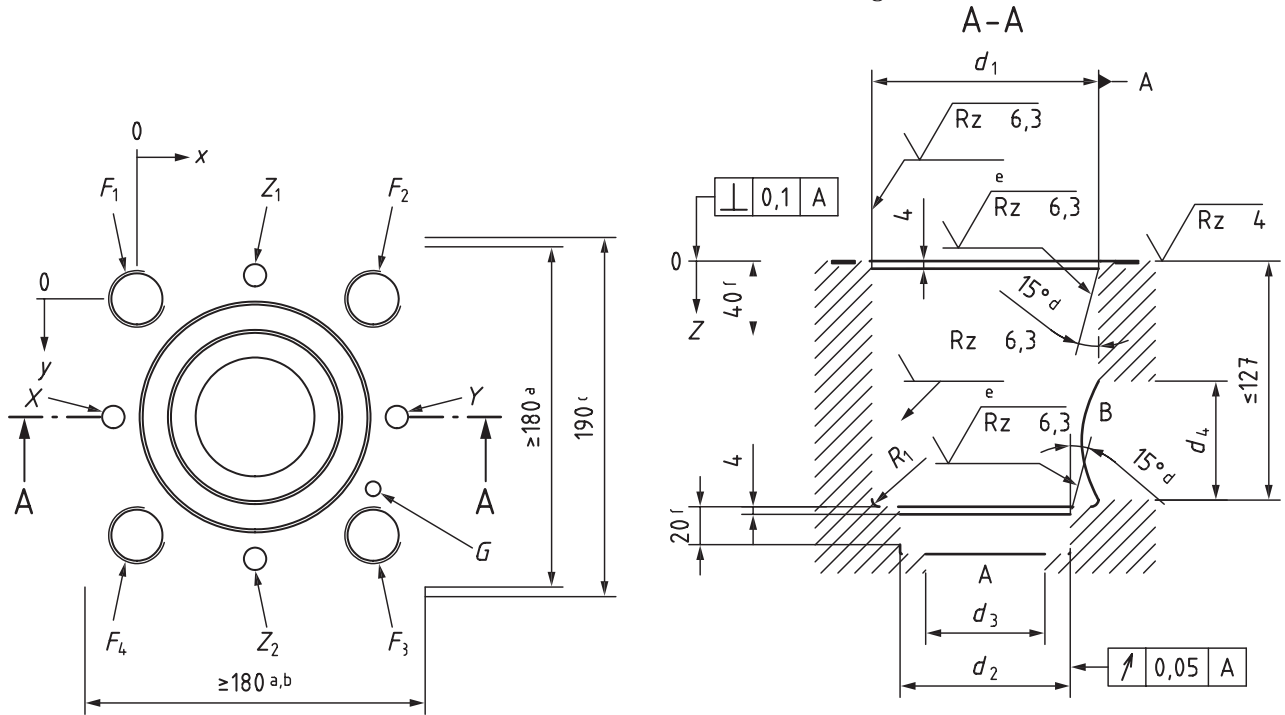

Key

- a The dimension specifying the area within the chain lines is the minimum dimension for mounting the cartridge valve cover. The corners of the square may be rounded to a maximum radius, r_{max} , equal to the thread diameter of the fixing screws. Along each axis, the fixing holes are at equal distances to the valve cover mounting surface edges.
- b Pilot valves and adjustment devices may exceed this dimension.
- c This dimension gives the minimum space required for a two-port hydraulic slip-in cartridge valve and its cover with this cavity. The dimension is also the minimum distance from centreline to centreline of two identical cavities on a manifold. The valve manufacturer’s attention is drawn to the fact that no part of the complete valve assembly shall exceed this dimension.
- d No burrs permitted in this area; the edges shall be rounded.
- e Visual examination.
- f Minimum length over which the specified surface finish shall apply.

Figure 12 — Cavity for two-port hydraulic slip-in cartridge main system pressure-relief valves with main ports of 63 mm nominal diameter (size 12) and square flange cover (code: 7368 - 12 - 12 - 1 - 16)

Table 12 — Cavity for two-port hydraulic slip-in cartridge main system pressure-relief valves with main ports of 63 mm nominal diameter (size 12) and square flange cover

Dimensions in millimetres

Axis	d_1^e	d_2^e	d_3^c	$d_4^{b,c}$	X^c	Y^c	Z_1^c	Z_2^c	F_1^a	F_2^a	F_3^a	F_4^a	$G^{d,e}$	R_1
	$\varnothing 120$ H7	$\varnothing 90$ H7	$\varnothing 63$ max.	$\varnothing 63$	$\varnothing 12$ max.	$\varnothing 12$ max.	$\varnothing 12$ max.	$\varnothing 12$ max.	M30	M30	M30	M30	$\varnothing 8$ H13	max. R 4
x	62,5	62,5	62,5	—	-12,5	137,5	62,5	62,5	0	125	125	0	125	—
y	62,5	62,5	62,5	—	62,5	62,5	-12,5	137,5	0	0	125	125	100,5	—
z	$130 \pm 0,3$	$155 + 0,1$	—	—	—	—	—	—	—	—	—	—	8 min.	—

a The minimum thread depth is 1,8 times the screw diameter, D . The recommended full thread depth is $2 \cdot D + 6$ mm to facilitate interchangeability of valves and to reduce the number of fixing screw lengths. However, sufficient distance from fixing hole to port B shall be respected. The recommended engagement of fixing screw thread for ferrous mounting is $1,25 \cdot D$.

b Suggested diameter of port B, but may be of any size located within the space between the dimensions indicated as 40 mm and 127 mm; port B is not necessarily machined and may be provided by casting.

c The depth and angle of the pilot ports and the main ports are determined by the graphical layout of the hydraulic circuit and by the location of the valves in the manifold.

d Blind hole to accommodate the locating pin on the valve cover.

e The depth of d_1 , d_2 and G are given in the tables as dimension z .

Dimensions and geometrical tolerances in millimetres

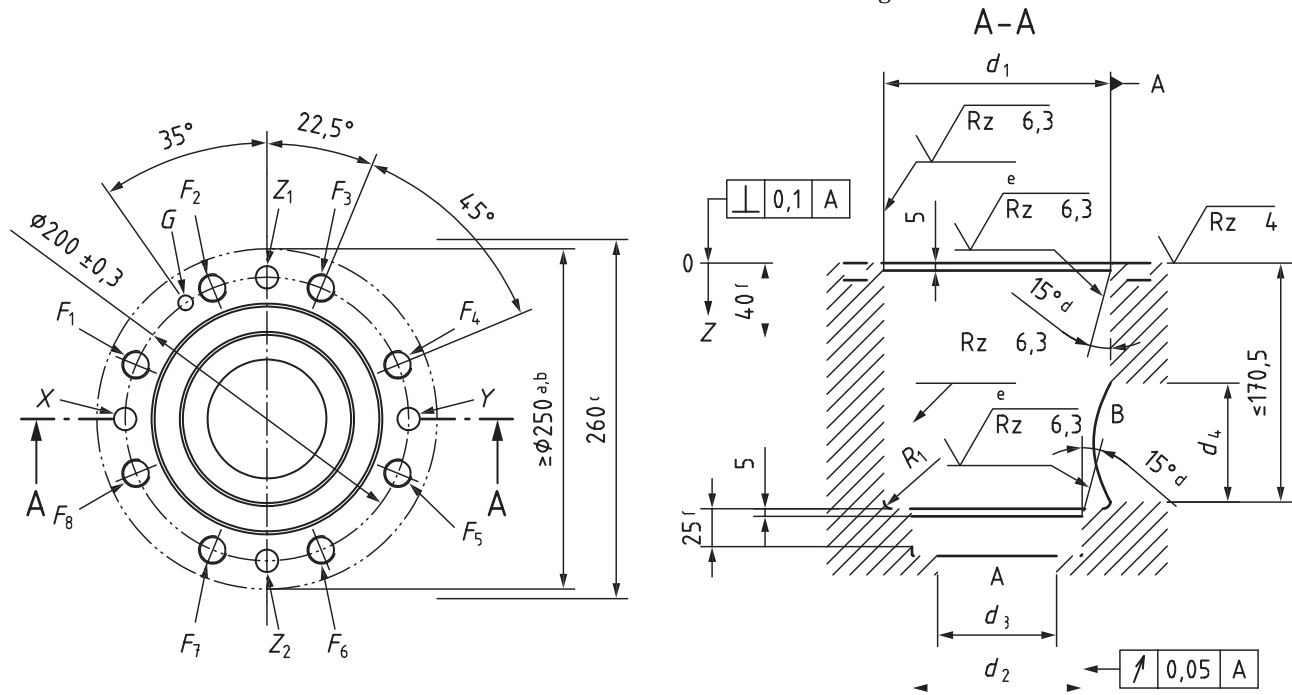

Key

- a The dimension specifying the area within the chain lines is the minimum dimension for mounting the cartridge valve cover. The fixing holes are arranged on a circular centre axis at equal distance to the valve cover mounting surface edges.
- b Pilot valves and adjustment devices may exceed this dimension.
- c This dimension gives the minimum space required for a two-port hydraulic slip-in cartridge valve and its cover with this cavity. The dimension is also the minimum distance from centreline to centreline of two identical cavities on a manifold. The valve manufacturer’s attention is drawn to the fact that no part of the complete valve assembly shall exceed this dimension.
- d No burrs permitted in this area; the edges shall be rounded.
- e Visual examination.
- f Minimum length over which the specified surface finish shall apply.

Figure 13 — Cavity for two-port hydraulic slip-in cartridge valves of all types, except main system pressure-relief valves, with main ports of 80 mm nominal diameter (size 13) and circular flange cover (code 7368 - 13 - 13 - 1 - 16)

Table 13 — Cavity for two-port hydraulic slip-in cartridge valves of all types, except main system pressure-relief valves, with main ports of 80 mm nominal diameter (size 13) and circular flange cover

Dimensions in millimetres

Dimension	d_1^e	d_2^e	d_3^c	$d_4^{b,c}$	X^c	Y^c	Z_1^c	Z_2^c	F_1^a	F_2^a	F_3^a	F_4^a	F_5^a	F_6^a	F_7^a	F_8^a	$G^{d,e}$	R_1
	∅ 145 H7	∅ 110 H7	∅ 80 max.	∅ 80	∅ 16 max.	∅ 16 max.	∅ 16 max.	∅ 16 max.	M24	M24	M24	M24	M24	M24	M24	M24	∅ 10 H13	max. R 4
z	175 ± 0,4	205 +0,1	—	—	—	—	—	—	—	—	—	—	—	—	—	—	8 min.	—
<p>^a The minimum thread depth is 1,8 times the screw diameter, D. The recommended full thread depth is $2 \cdot D + 6$ mm to facilitate interchangeability of valves and to reduce the number of fixing screw lengths. However, sufficient distance from fixing hole to port B shall be respected. The recommended engagement of fixing screw thread for ferrous mounting is $1,25 \cdot D$.</p> <p>^b Suggested diameter of port B, but may be of any size located within the space between the dimensions indicated as 40 mm and 170,5 mm; port B is not necessarily machined and may be provided by casting.</p> <p>^c The depth and angle of the pilot ports and the main ports are determined by the graphical layout of the hydraulic circuit and by the location of the valves in the manifold.</p> <p>^d Blind hole to accommodate the locating pin on the valve cover.</p> <p>^e The depth of d_1, d_2 and G are given in the tables as dimension z.</p>																		

Dimensions and geometrical tolerances in millimetres

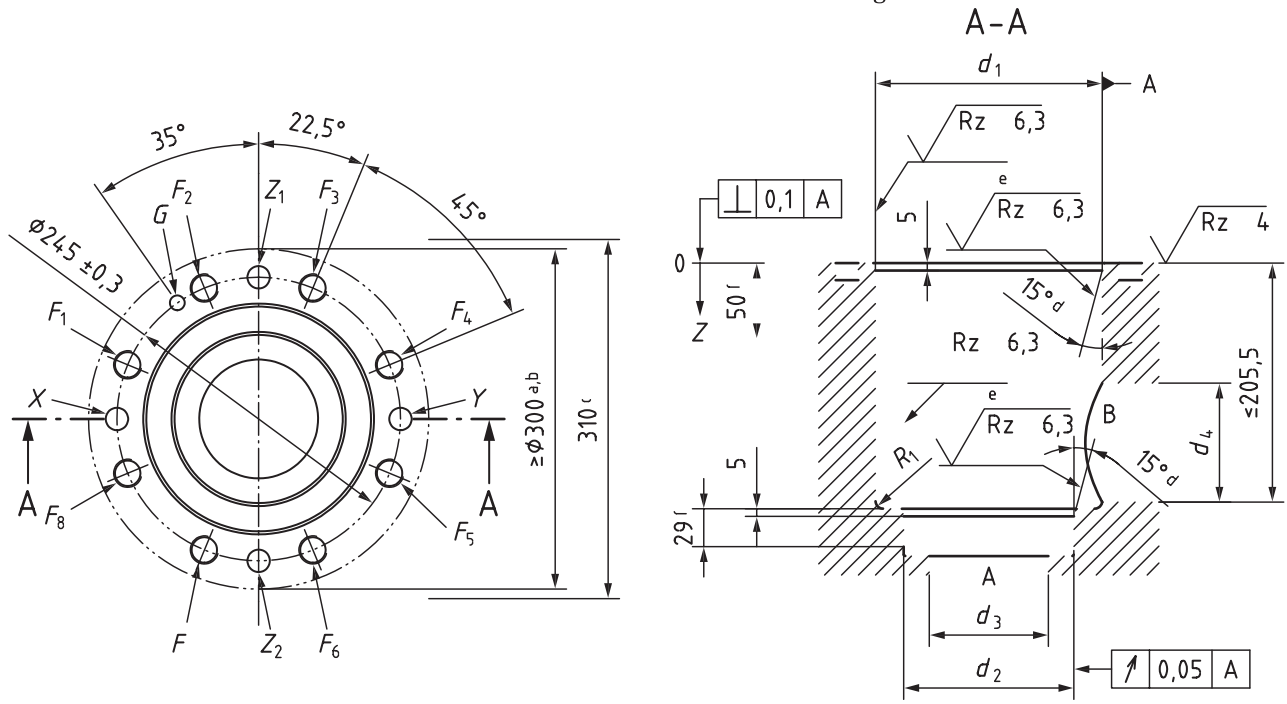

Key

- a The dimension specifying the area within the chain lines is the minimum dimension for mounting the cartridge valve cover. The fixing holes are arranged on a circular centre axis at equal distance to the valve cover mounting surface edges.
- b Pilot valves and adjustment devices may exceed this dimension.
- c This dimension gives the minimum space required for a two-port hydraulic slip-in cartridge valve and its cover with this cavity. The dimension is also the minimum distance from centreline to centreline of two identical cavities on a manifold. The valve manufacturer’s attention is drawn to the fact that no part of the complete valve assembly shall exceed this dimension.
- d No burrs permitted in this area; the edges shall be rounded.
- e Visual examination.
- f Minimum length over which the specified surface finish shall apply.

Figure 14 — Cavity for two-port hydraulic slip-in cartridge valves of all types, except main system pressure-relief valves, with main ports of 100 mm nominal diameter (size 14) and circular flange cover (code: 7368 - 14 - 14 - 1 - 16)

Table 14 — Cavity for two-port hydraulic slip-in cartridge valves of all types, except main system pressure-relief valves, with main ports of 100 mm nominal diameter (size 14) and circular flange cover

Dimensions in millimetres

Dimension	d_1^e	d_2^e	d_3^c	$d_4^{b,c}$	X^c	Y^c	Z_1^c	Z_2^c	F_1^a	F_2^a	F_3^a	F_4^a	F_5^a	F_6^a	F_7^a	F_8^a	$G^{d,e}$	R_1
	∅ 180 H7	∅ 135 H7	∅ 100 max.	∅ 100	∅ 20 max.	∅ 20 max.	∅ 20 max.	∅ 20 max.	M30	M30	M30	M30	M30	M30	M30	M30	∅ 10 H13	max. R 4
z	210 ± 0,4	245 + 0,1	—	—	—	—	—	—	—	—	—	—	—	—	—	—	8 min.	—
<p>^a The minimum thread depth is 1,8 times the screw diameter, D. The recommended full thread depth is $2 \cdot D + 6$ mm to facilitate interchangeability of valves and to reduce the number of fixing screw lengths. However, sufficient distance from fixing hole to port B shall be respected. The recommended engagement of fixing screw thread for ferrous mounting is $1,25 \cdot D$.</p> <p>^b Suggested diameter of port B, but may be of any size located within the space between the dimensions indicated as 50 mm and 205,5 mm; port B is not necessarily machined and may be provided by casting.</p> <p>^c The depth and angle of the pilot ports and the main ports are determined by the graphical layout of the hydraulic circuit and by the location of the valves in the manifold.</p> <p>^d Blind hole to accommodate the locating pin on the valve cover.</p> <p>^e The depth of d_1, d_2 and G are given in the tables as dimension z.</p>																		

Dimensions and geometrical tolerances in millimetres

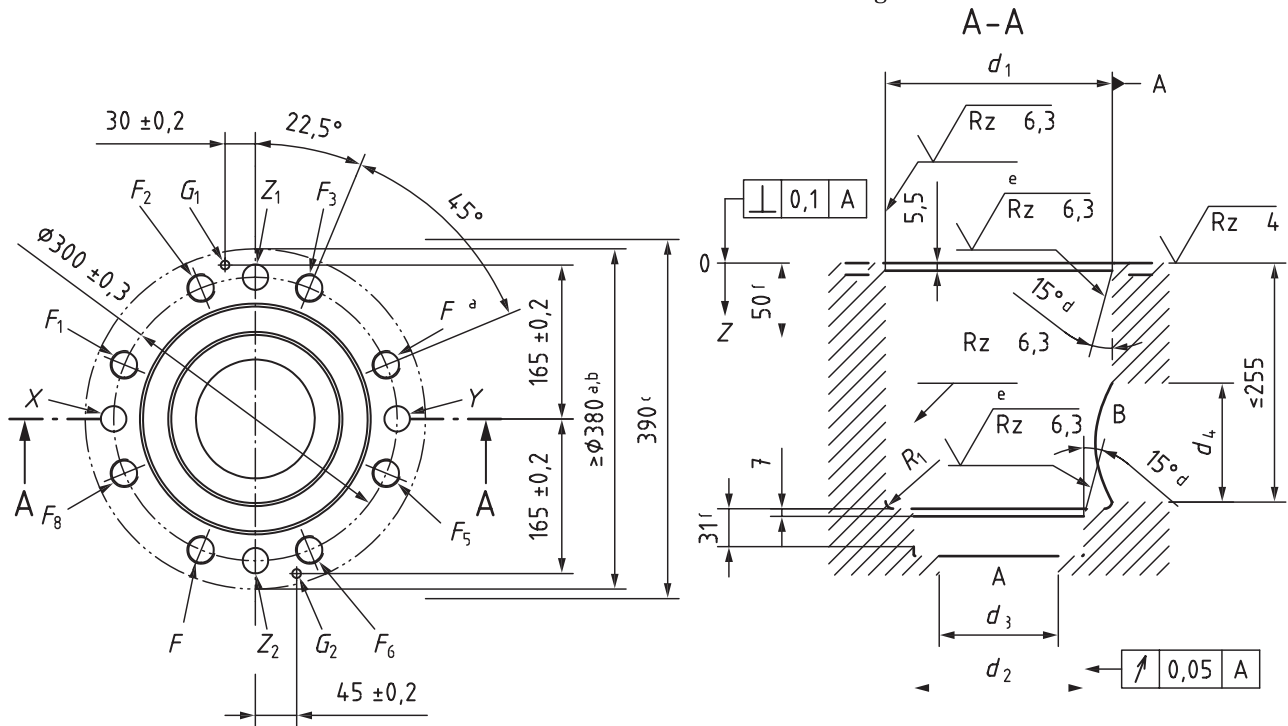

Key

- a The dimension specifying the area within the chain lines is the minimum dimension for mounting the cartridge valve cover. The fixing holes are arranged on a circular centre axis at equal distance to the valve cover mounting surface edges.
- b Pilot valves and adjustment devices may exceed this dimension.
- c This dimension gives the minimum space required for a two-port hydraulic slip-in cartridge valve and its cover with this cavity. The dimension is also the minimum distance from centreline to centreline of two identical cavities on a manifold. The valve manufacturer’s attention is drawn to the fact that no part of the complete valve assembly shall exceed this dimension.
- d No burrs permitted in this area; the edges shall be rounded.
- e Visual examination.
- f Minimum length over which the specified surface finish shall apply.

Figure 15 — Cavity for two-port hydraulic slip-in cartridge valves of all types, except main system pressure-relief valves, with main ports of 125 mm nominal diameter (size 15) and circular flange cover (code: 7368 - 15 - 15 - 1 - 16)

Table 15 — Cavity for two-port hydraulic slip-in cartridge valves of all types, except main system pressure-relief valves, with main ports of 125 mm nominal diameter (size 15) and circular flange cover

Dimensions in millimetres

Dimension	d_1^e	d_2^e	d_3^c	$d_4^{b,c}$	X^c	Y^c	Z_1^c	Z_2^c	F_1^a	F_2^a	F_3^a	F_4^a	F_5^a	F_6^a	F_7^a	F_8^a	$G_1^{d,e}$	$G_2^{d,e}$	R_1
	∅ 225 H7	∅ 200 H7	∅ 150 max.	∅ 125	∅ 32 max.	∅ 32 max.	∅ 32 max.	∅ 32 max.	M36	M36	M36	M36	M36	M36	M36	M36	∅ 10 H13	∅ 10 H13	max. R 4
z	257 ± 0,5	300 + 0,15	—	—	—	—	—	—	—	—	—	—	—	—	—	—	10 min.	10 min.	—
<p>^a The minimum thread depth is 1,8 times the screw diameter, D. The recommended full thread depth is $2 \cdot D + 6$ mm to facilitate interchangeability of valves and to reduce the number of fixing screw lengths. However, sufficient distance from fixing hole to port B shall be respected. The recommended engagement of fixing screw thread for ferrous mounting is $1,25 \cdot D$.</p> <p>^b Suggested diameter of port B, but may be of any size located within the space between the dimensions indicated as 50 mm and 255 mm; port B is not necessarily machined and may be provided by casting.</p> <p>^c The depth and angle of the pilot ports and the main ports are determined by the graphical layout of the hydraulic circuit and by the location of the valves in the manifold.</p> <p>^d Blind hole to accommodate the locating pin on the valve cover.</p> <p>^e The depth of d_1, d_2, G_1 and G_2 are given in the tables as dimension z.</p>																			

Dimensions and geometrical tolerances in millimetres

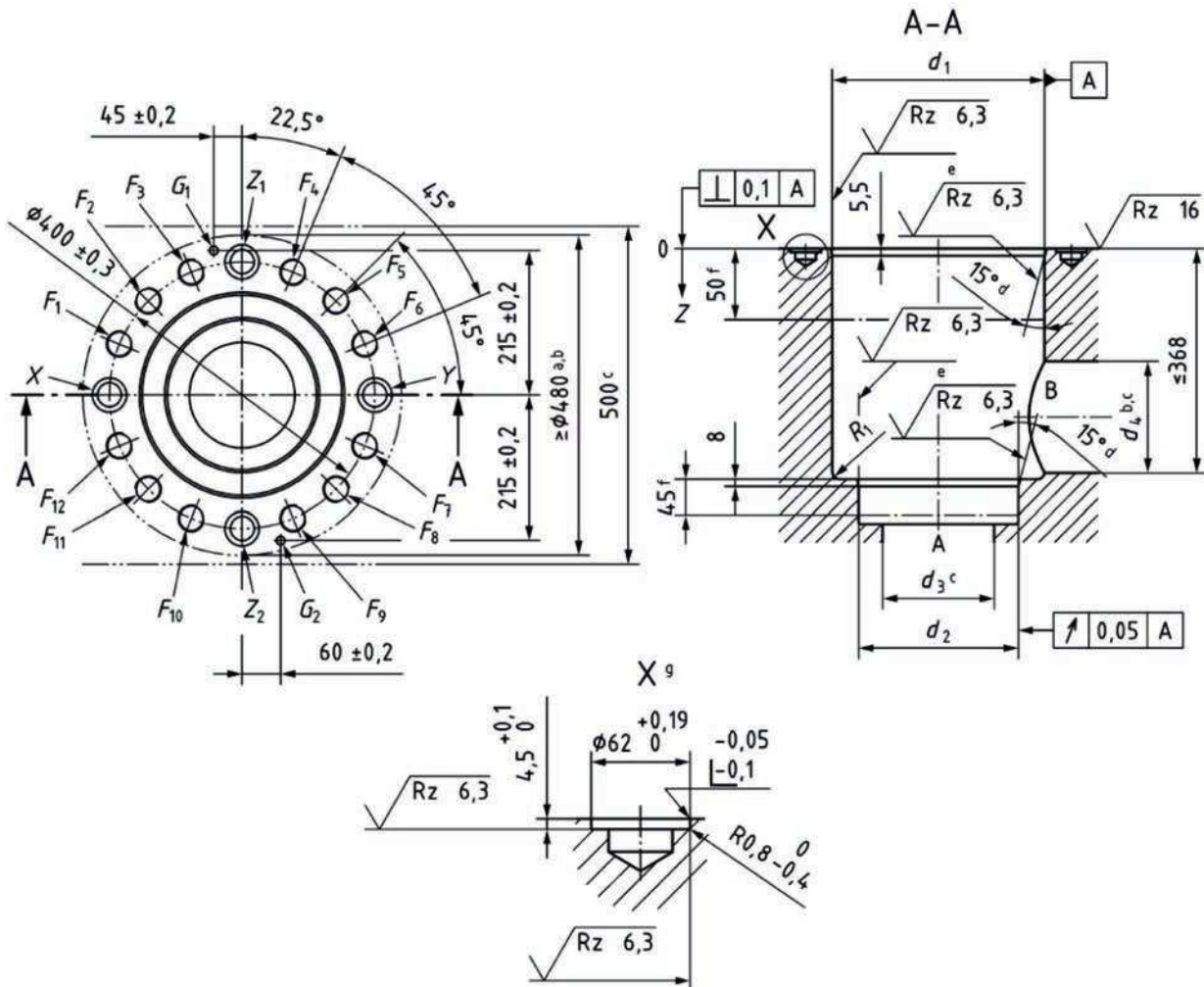

Key

- a The dimension specifying the area within the chain lines is the minimum dimension for mounting the cartridge valve cover. The fixing holes are arranged on a circular centre axis at equal distance to the valve cover mounting surface edges.
- b Pilot valves and adjustment devices may exceed this dimension.
- c This dimension gives the minimum space required for a two-port hydraulic slip-in cartridge valve and its cover with this cavity. The dimension is also the minimum distance from centreline to centreline of two identical cavities on a manifold. The valve manufacturer’s attention is drawn to the fact that no part of the complete valve assembly shall exceed this dimension.
- d No burrs permitted in this area; the edges shall be rounded.
- e Visual examination.
- f Minimum length over which the specified surface finish shall apply.
- g Ports X, Y, Z₁ and Z₂.

Figure 16 — Cavity for two-port hydraulic slip-in cartridge valves of all types, except main system pressure-relief valves, with main ports of 160 mm nominal diameter (size 16) and circular flange cover (code: 7368 - 16 - 16 - 1 - 16)

Table 16 — Cavity for two-port hydraulic slip-in cartridge valves of all types, except main system pressure-relief valves, with main ports of 160 mm nominal diameter (size 16) and circular flange cover

Dimensions in millimetres

Dimension	d_1^e	d_2^e	d_3^c	$d_4^{b,c}$	X^c	Y^c	Z_1^c	Z_2^c	F_1^a	F_2^a	F_3^a	F_4^a	F_5^a	F_6^a	F_7^a	F_8^a	F_9^a	F_{10}^a	F_{11}^a	F_{12}^a	$G_1^{d,e}$	$G_2^{d,e}$	R_1
	ø 300 H7	ø 270 H7	ø 200 max.	ø 160	ø 40 max.	ø 40 max.	ø 40 max.	ø 40 max.	M42	M42	M42	M42	M42	M42	M42	M42	M42	M42	M42	M42	M42	ø 10 H13	ø 10 H13
z	370 ± 0,5	425 + 0,15	—	—	—	—	—	—	—	—	—	—	—	—	—	—	—	—	—	—	10 min.	10 min.	—
<p>^a The minimum thread depth is 1,8 times the screw diameter, D. The recommended full thread depth is $2 \cdot D + 6$ mm to facilitate interchangeability of valves and to reduce the number of fixing screw lengths. However, sufficient distance from fixing hole to port B shall be respected. The recommended engagement of fixing screw thread for ferrous mounting is $1,25 \cdot D$.</p> <p>^b Suggested diameter of port B, but may be of any size located within the space between the dimensions indicated as 50 mm and 368 mm; port B is not necessarily machined and may be provided by casting.</p> <p>^c The depth and angle of the pilot ports and the main ports are determined by the graphical layout of the hydraulic circuit and by the location of the valves in the manifold.</p> <p>^d Blind hole to accommodate the locating pin on the valve cover.</p> <p>^e The depth of d_1, d_2, G_1 and G_2 are given in the tables as dimension z.</p>																							

Bibliography

- [1] ISO 129-1, *Technical drawings — Indication of dimensions and tolerances — Part 1: General principles*
- [2] ISO 286-2, *Geometrical product specifications (GPS) — ISO code system for tolerances on linear sizes — Part 2: Tables of standard tolerance classes and limit deviations for holes and shafts*
- [3] ISO 965-1, *ISO general purpose metric screw threads — Tolerances — Part 1: Principles and basic data*
- [4] ISO 1101, *Geometrical product specification (GPS) — Geometrical tolerancing — Tolerances of form, orientation, location and run-out*
- [5] ISO 4288, *Geometrical Product Specifications (GPS) — Surface texture: Profile method — Rules and procedures for the assessment of surface texture*
- [6] ISO 4413, *Hydraulic fluid power — General rules and safety requirements for systems and their components*
- [7] ISO 5598, *Fluid power systems and components — Vocabulary*
- [8] ISO 5783, *Hydraulic fluid power — Code for identification of valve mounting surfaces and cartridge valve cavities*

