**Ski-poles for alpine skiing —
Requirements and test methods**

Bâtons de skis alpins — Exigences et méthodes d'essai



Reference number
ISO 7331:2011(E)

© ISO 2011



COPYRIGHT PROTECTED DOCUMENT

© ISO 2011

All rights reserved. Unless otherwise specified, no part of this publication may be reproduced or utilized in any form or by any means, electronic or mechanical, including photocopying and microfilm, without permission in writing from either ISO at the address below or ISO's member body in the country of the requester.

ISO copyright office
Case postale 56 • CH-1211 Geneva 20
Tel. + 41 22 749 01 11
Fax + 41 22 749 09 47
E-mail copyright@iso.org
Web www.iso.org

Published in Switzerland

Contents

Page

Foreword	iv
1 Scope	1
2 Normative references	1
3 Terms and symbols	1
3.1 Terms	1
3.2 Symbols	2
4 Categories of ski-poles	3
5 Materials	3
6 Test conditions	3
7 Test sample	4
8 Requirements and test methods	4
8.1 Total length	4
8.2 Outward design	4
8.3 Anti-catching design	5
8.4 Release mechanism	5
8.5 Grip	6
8.6 Straps	8
8.7 Shaft	10
8.8 Basket	13
8.9 Tip	15
9 Marking	17

.....

Foreword

ISO (the International Organization for Standardization) is a worldwide federation of national standards bodies (ISO member bodies). The work of preparing International Standards is normally carried out through ISO technical committees. Each member body interested in a subject for which a technical committee has been established has the right to be represented on that committee. International organizations, governmental and non-governmental, in liaison with ISO, also take part in the work. ISO collaborates closely with the International Electrotechnical Commission (IEC) on all matters of electrotechnical standardization.

International Standards are drafted in accordance with the rules given in the ISO/IEC Directives, Part 2.

The main task of technical committees is to prepare International Standards. Draft International Standards adopted by the technical committees are circulated to the member bodies for voting. Publication as an International Standard requires approval by at least 75 % of the member bodies casting a vote.

Attention is drawn to the possibility that some of the elements of this document may be the subject of patent rights. ISO shall not be held responsible for identifying any or all such patent rights.

ISO 7331 was prepared by Technical Committee ISO/TC 83, *Sports and recreational equipment*, Subcommittee SC 4, *Snowsports equipment*.

This fourth edition cancels and replaces the third edition (ISO 7331:2005), which has been technically revised.

.....

Ski-poles for alpine skiing — Requirements and test methods

1 Scope

This International Standard defines the minimum requirements for safety in ski-poles for alpine skiing and specifies test methods to check conformity with these requirements.

It is applicable to ski-poles for alpine skiing in the following ranges of total length, l_T (see Clause 3):

- group A, $l_T \geq 1\ 050$ mm (adults' poles);
- group B, $1\ 050$ mm $> l_T \geq 700$ mm (junior poles);
- group C, $l_T \leq 700$ mm (children's poles).

Special designs may deviate from this International Standard, but shall be marked in a durable manner as special designs (see 9.2).

2 Normative references

The following referenced documents are indispensable for the application of this document. For dated references, only the edition cited applies. For undated references, the latest edition of the referenced document (including any amendments) applies.

ISO 554, *Standard atmospheres for conditioning and/or testing — Specifications*

ISO 6508-1, *Metallic materials — Rockwell hardness test — Part 1: Test method (scales A, B, C, D, E, F, G, H, K, N, T)*

ISO 6508-2, *Metallic materials — Rockwell hardness test — Part 2: Verification and calibration of testing machines (scales A, B, C, D, E, F, G, H, K, N, T)*

ISO 6508-3, *Metallic materials — Rockwell hardness test — Part 3: Calibration of reference blocks (scales A, B, C, D, E, F, G, H, K, N, T)*

3 Terms and symbols

3.1 Terms

Terms used to designate the different parts of a ski-pole are given in Figure 1.

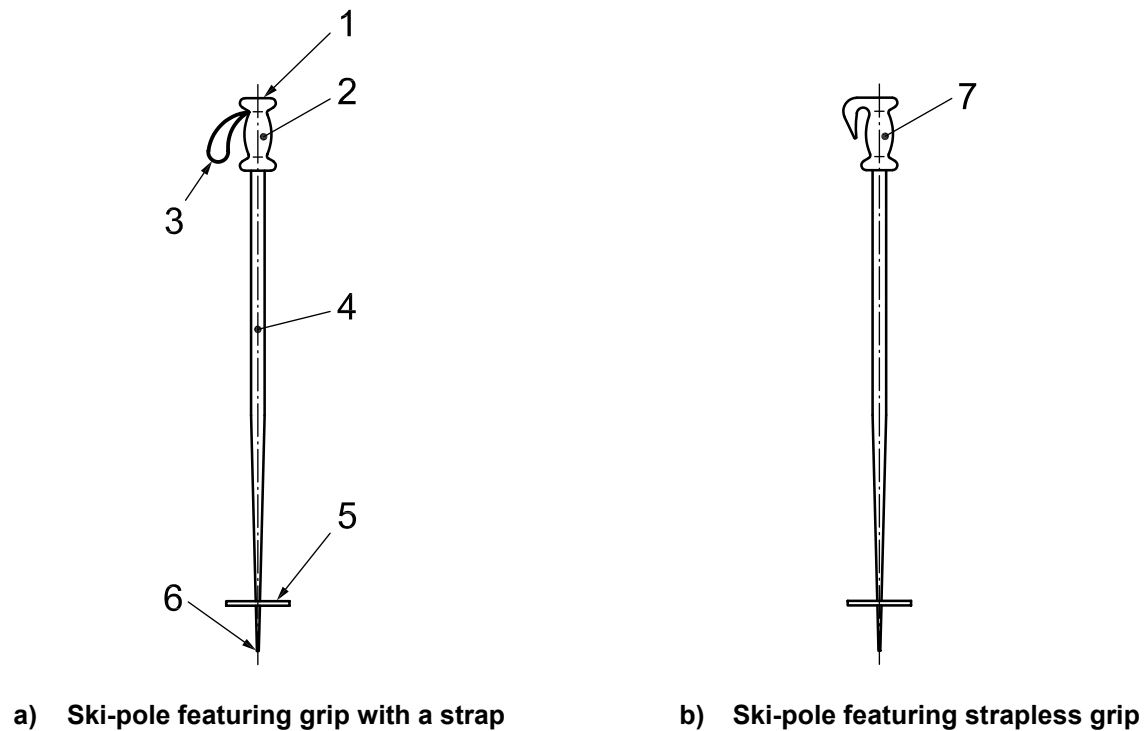

Key

- 1 upper surface of the grip, A_G
- 2 grip
- 3 strap
- 4 shaft
- 5 basket
- 6 tip
- 7 strapless grip

Figure 1 — Terms used to designate the parts of a ski-pole

3.2 Symbols

The symbols used in Figures 1 and 2 relate to the following concepts, which shall be expressed in the units given:

- A_G is the upper surface, expressed in square centimetres, of the grip (impact area);
- $-F_Z$ is the compressive force, expressed in newtons, in the axis of the ski-pole;
- l_T is the total length, in millimetres;
- l_H is the length, expressed in millimetres, measured from the tip to the middle of the hand;
- l_B is the length, expressed in millimetres, measured from the tip to the lower surface of the basket;
- d_B is the maximum diameter, expressed in millimetres, of the basket.

4 Categories of ski-poles

The length, l_H , is determined by reference to the width of an average hand:

- group A: 93 mm;
- group B: 73 mm;
- group C: 57 mm.

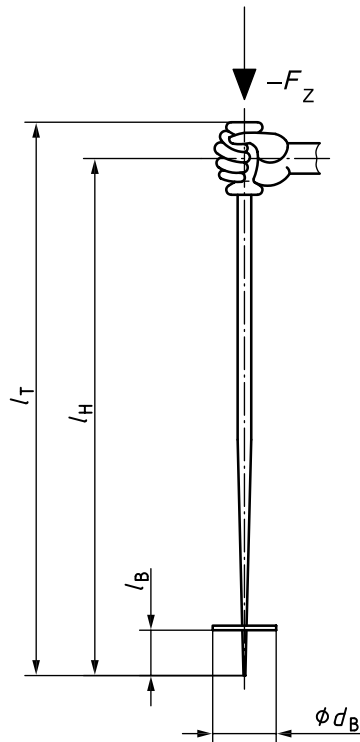

Figure 2 — Centre of rotation and dimensions

5 Materials

The materials used shall meet the requirements specified in Clause 8.

6 Test conditions

Unless otherwise specified, the test shall be carried out as a type test in the standard atmosphere in accordance with ISO 554 with reduced tolerances.

The reference value for the quasi-static structure of force, F , with respect to time, t , expressed in newtons per second (N/s), is given by:

$$\frac{dF}{dt} \leq 100 \text{ N/s}$$

ISO 7331:2011(E)

The test equipment shall be such that all measurable variables such as forces, temperatures, angles, lengths, surfaces, masses and time of oscillation can be measured or determined to the following accuracies:

- Forces, masses: $\pm 2\%$;
- Temperatures: $\pm 2\text{ }^{\circ}\text{C}$;
- Angles: $\pm 1^{\circ}$;
- Lengths of poles: $\pm 1\text{ mm}$;
- Radii and other lengths: $\pm 0,2\text{ mm}$.

7 Test sample

The three longest and the three shortest poles from each group shall be submitted to the laboratory.

In addition, three poles of 1 200 mm length l_T from testing group A, and three poles of 1 000 mm length l_T from testing group B shall be submitted to the laboratory.

One long pole and one short pole shall be selected for the tests to be carried out in accordance with Clause 8.

If one test sample fails these tests, the tests may be repeated with two further test poles, both of which then shall pass the repeated tests.

8 Requirements and test methods

8.1 Total length

8.1.1 Requirement

The total length l_T shall not vary from the given length by more than $\pm 10\text{ mm}$. Furthermore, the lengths of one pair of ski-poles shall not differ by more than 7 mm.

8.1.2 Testing

Determine lengths of all test samples indicated in Clause 7.

8.2 Outward design

8.2.1 Requirement

Sharp design (except the tip) and rough surfaces, which might cause injury, shall be avoided.

8.2.2 Testing

Check visually.

8.3 Anti-catching design

8.3.1 Requirement

The ski-pole shall be designed to limit the strain that can be transmitted to the wrist and arm of the skier, should the pole get caught during skiing. This requirement can be met by a design according to 8.6.3 or 8.8.4, or by a strapless grip.

8.3.2 Testing

Test according to 8.6.3 or 8.8.4, or carry out a visual and functional test.

8.4 Release mechanism

8.4.1 Function

If so equipped, a release mechanism shall be manufactured so that it functions correctly in environmental conditions encountered during skiing.

8.4.2 Temperature and ice conditions

8.4.2.1 Requirement

If a release mechanism is provided in the shaft, the compressive force in the axis of the pole necessary to cause the release at a temperature of $-20\text{ }^{\circ}\text{C}$ and in icy conditions, and at a temperature of $20\text{ }^{\circ}\text{C}$, shall not vary by more than 30 %.

In addition, the release force at $-20\text{ }^{\circ}\text{C}$ and in icy conditions shall not exceed the values given in 8.6.3.

8.4.2.2 Testing

Determine the release force at $20\text{ }^{\circ}\text{C}$ five times per function on one test sample and calculate the mean value.

Store the release mechanism at a temperature of $-20\text{ }^{\circ}\text{C}$ until this temperature is reached. Determine the release force once and compare it with the mean value at $20\text{ }^{\circ}\text{C}$.

Again determine the release force at $20\text{ }^{\circ}\text{C}$ five times on one test sample and calculate the mean value.

Spray the vertically placed ski-pole with water at $10\text{ }^{\circ}\text{C}$ or more for 1 min from a distance of 1 m. Store the pole vertically at $-20\text{ }^{\circ}\text{C}$ until it reaches this temperature, then determine the release force once and compare it with the mean value at $20\text{ }^{\circ}\text{C}$.

8.4.3 Fatigue conditions

8.4.3.1 Requirement

The release mechanisms shall be protected against wear so that they still function correctly after 100 releases.

The release forces shall not vary by more than 20 % after the fatigue test.

8.4.3.2 Testing

Carry out 100 releases on each release mechanism; compare the mean value of the first five releases with the mean value of the last five.

8.5 Grip

8.5.1 Shape

8.5.1.1 Requirement

The shape of the grip shall be designed to facilitate good control of the pole, i.e. the grip shall be shaped to the hand and shall not be slippery. With all grips, whether straps are included or not, the shape of the moulded portion shall not be such as to force the thumb outward or upward beyond the edge of the impact area, A_G , of the top of the handle/grip.

8.5.1.2 Testing

This is accomplished by both visual and manual means.

8.5.2 Impact area

8.5.2.1 Requirement

The impact area, A_G , shall be:

- group A: $\geq 13 \text{ cm}^2$;
- group B: $\geq 10 \text{ cm}^2$;
- group C: $\geq 7 \text{ cm}^2$.

8.5.2.2 Testing

Designate the largest section, taken from the outer contour at a level between 0 mm and 10 mm from the upper edge of the grip and at a slope of between 0° and 10° to the perpendicular; this shall be the impact area.

In the case of deformable surfaces of the grip, this measurement can be carried out at a compressive force of 400 N.

8.5.3 Edges

8.5.3.1 Requirement

Edges on the grip, which could cause injury, shall have a radius of at least 2 mm. Soft grips (with a hardness of <80 Shore A at -10°C) may have a radius of at least 1 mm.

8.5.3.2 Testing

This is accomplished by both visual and dimensional means.

8.5.4 Piercing resistance

8.5.4.1 Requirement

The piercing resistance of the impact area, A_G , to the top of the shaft, i.e. the force necessary for the shaft to pierce the impact area upwards, shall be higher by at least 100 % than the maximum compressive force, or than the maximum release force of those poles with a release mechanism.

8.5.4.2 Testing

Press a test sample against a fixed abutment by means of a plate (see Figure 3).

When the double compressive force, determined according to 8.7.2.2, is applied, the shaft shall not pierce the end of the grip. Carry out the test quasi-statically.

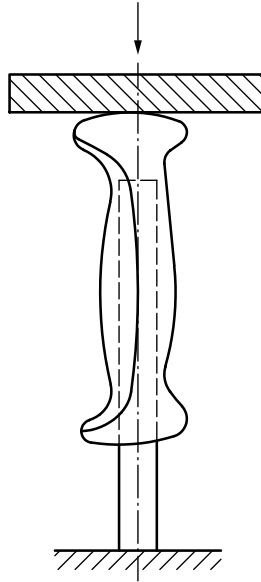

Figure 3 — Test arrangement for piercing resistance

8.5.5 Pulling-off force

8.5.5.1 Requirement

The force needed to pull the grip from the shaft shall be:

- group A: ≥ 350 N;
- group B: ≥ 350 N;
- group C: ≥ 300 N.

8.5.5.2 Testing

Carry out the test on a test sample in accordance with Figure 4.

Carry out the test quasi-statically.

8.5.6 Strapless grips

8.5.6.1 Requirement

The bow of strapless grips shall be designed in such a way that the risk of catching or twisting the wrist is reduced.

8.5.6.2 Testing

This is accomplished by visual means.



Figure 4 — Test arrangement for pulling-off force

8.6 Straps

8.6.1 Width

8.6.1.1 Requirement

Straps shall have the following width where in contact with the hand:

- group A: ≥ 16 mm;
- group B: ≥ 14 mm;
- group C: ≥ 12 mm.

8.6.1.2 Testing

This is accomplished by both visual and dimensional means.

8.6.2 Minimum strain in support direction

8.6.2.1 Requirement

Straps with a supporting function (i.e. groups A and B) shall withstand a force in the loading direction $-Z$, of ≥ 350 N.

Straps in group C have no supporting function.

8.6.2.2 Testing

Carry out the test quasi-statically according to Figure 5 by applying the force in the direction $-Z$.

8.6.3 Release function

8.6.3.1 Requirement

Straps with a release function shall have the following range of release values in the direction Z within a range of temperature from +20 °C to –5 °C:

- group A: 80 N to 240 N;
- group B: 60 N to 180 N.

8.6.3.2 Testing

Determine release forces in direction Z quasi-statically according to 8.4 and Figure 5.

Dimensions in millimetres

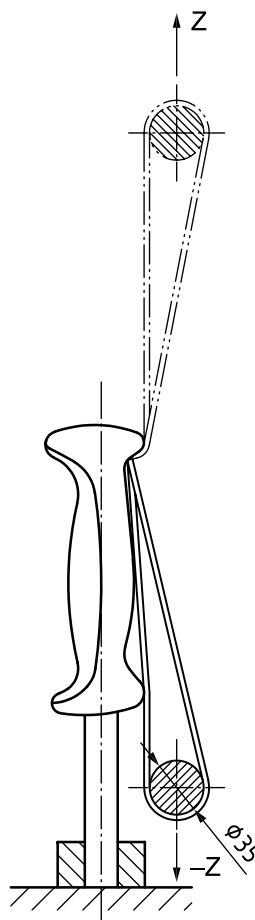

Figure 5 — Test arrangement for the strap

8.7 Shaft

8.7.1 Minimum compressive force

8.7.1.1 Requirement

The shaft shall be designed to withstand compressive forces and bending moments occurring during all aspects of skiing without plastic deformation or fracture.

No permanent deformation shall occur when loading the pole with a compressive force in the axis of the pole of:

- group A: 350 N;
- group B: 350 N;
- group C: 300 N.

8.7.1.2 Testing

Test the longest ski-pole of one series, taking l_H as the test length. Carry out the test quasi-statically between two parallel plates and with the pole fixed off-centre (see Figure 6). Test bent poles in such a way that buckling is promoted.

8.7.2 Maximum compressive force

8.7.2.1 Requirement

For group A, to obtain the best possible protection against injury to a skier falling on the impact area A_G , the ski-pole shall buckle on its axis under a maximum compressive force of 900 N, or shall be so designed as to glance off upon impact with the body of a skier.

8.7.2.2 Testing

Test three poles of group A with a length of 1 200 mm and three poles of group B with a length of 1 000 mm, taking l_T as the test length. The mean value of three tests shall fulfil the requirements.

Carry out the test quasi-statically between two parallel plates, and with the pole fixed centrally, to a tolerance of ± 2 mm (see Figure 7).

In the case of ski-poles with other safety features to glance off in the direction of fall, determine the maximum compressive force on the end surfaces of the test samples at the moment of impact from a released falling weight.

Dimensions in millimetres

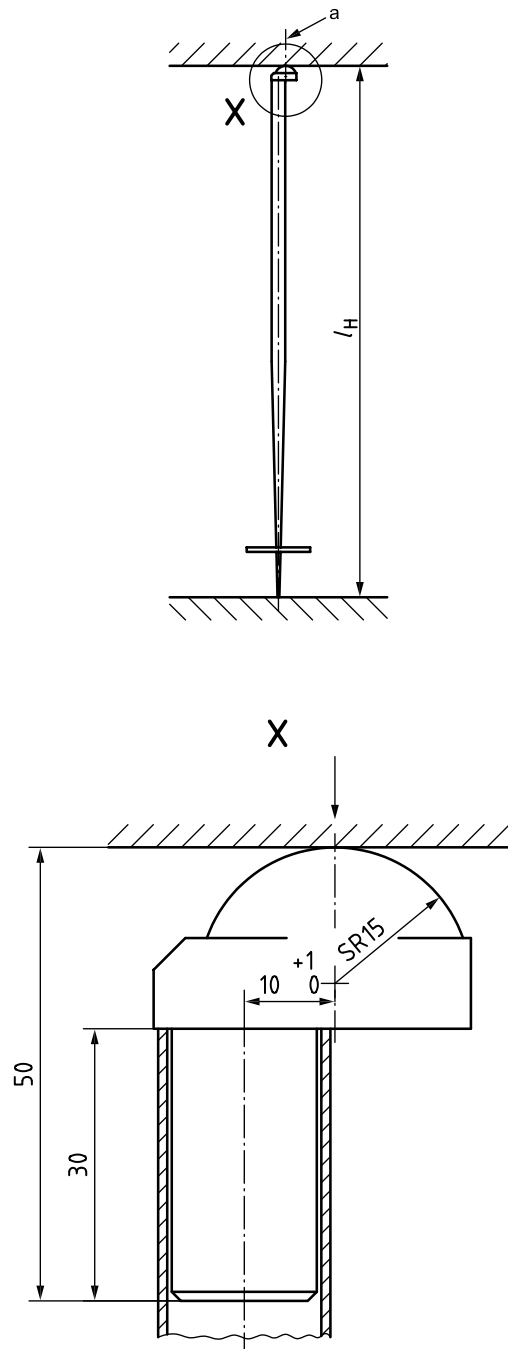

^a Line of effective applied force.

Figure 6 — Test arrangement for the determination of the minimum compressive force

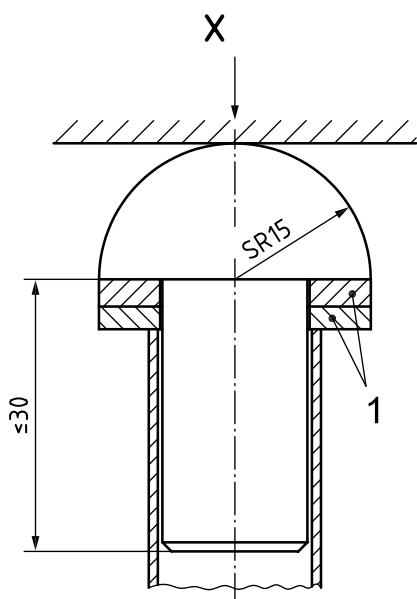
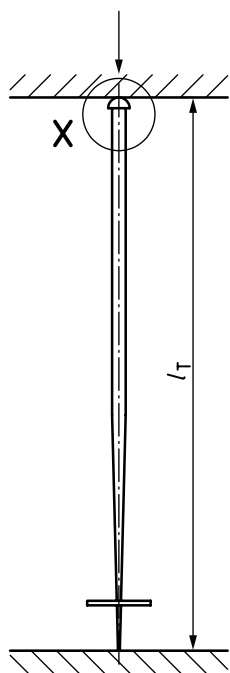

Key

- 1 compensating rings to attain l_T

Figure 7 — Test arrangement for the determination of the maximum compressive force

8.7.3 Point of buckling

8.7.3.1 Requirement

In the test, the ski-pole shall neither break into two parts nor splinter when compressed to $2/3 l_H$.

8.7.3.2 Testing

Test in accordance with Figure 6.

8.8 Basket

8.8.1 Dimensions

8.8.1.1 Requirement

The dimensions of d_B and l_B shall be chosen to fulfil the requirements of 8.9.2.

8.8.1.2 Testing

Test in accordance with 8.9.2.

8.8.2 Resistance

8.8.2.1 Requirement

The basket on the ski-pole shall withstand, without fracture, a surface force corresponding to the following forces in the direction $-Z$ at a temperature of $-20\text{ }^\circ\text{C}$:

- group A: 500 N for $-Z$ and 350 N for Z ;
- group B: 500 N for $-Z$ and 350 N for Z .

8.8.2.2 Testing

Carry out the test quasi-statically at a temperature of $-20\text{ }^\circ\text{C}$ on one test sample each in accordance with Figure 8 (direction $-Z$).

Dimensions in millimetres

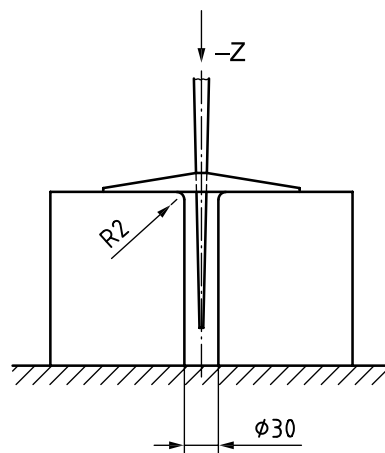

Figure 8 — Test arrangement for the basket and basket fixing in the direction of compression

8.8.3 Basket fixing

8.8.3.1 Requirement

The fixing of the basket shall withstand forces according to 8.8.2 without fracture in both directions Z and -Z at a temperature of -20 °C.

During the resistance test the movement of the basket on the shaft shall not exceed ±3 mm.

8.8.3.2 Testing

Carry out the test quasi-statically at a temperature of -20 °C on one test sample each in accordance with Figure 9 (direction Z).

Dimensions in millimetres

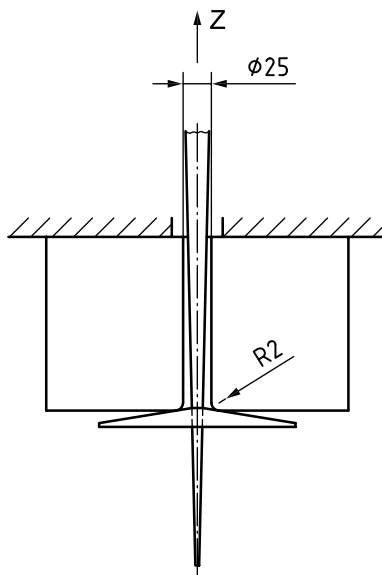

Figure 9 — Test arrangement for the basket fixing in the direction of the tensile force

8.8.4 Anti-catching design of basket

8.8.4.1 Requirement

If there is neither a strapless grip nor a release function strap, it shall be possible to pass the basket through a gap with a maximum force according to 8.6.3.1 at -20 °C (see Figure 10).

The basket pattern shall be designed to reduce the risk of catching.

8.8.4.2 Testing

Dimensions in millimetres

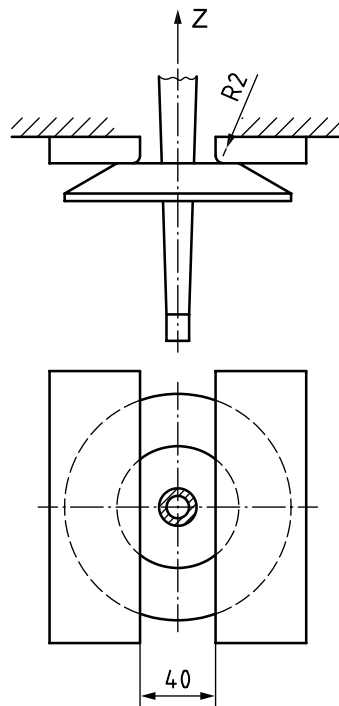

Figure 10 — Gap for testing the basket

8.9 Tip

8.9.1 Minimum area

8.9.1.1 Requirement

To reduce the danger of penetration, the section of the tip of the pole, measured perpendicular to the axis of the ski-pole at a distance of:

- group A: 2 mm;
- group B: 2 mm;
- group C: 1 mm;

from the extreme point, shall have a minimum area of:

- group A: 25 mm²;
- group B: 25 mm²;
- group C: 30 mm².

The geometry of the tip of the pole shall be designed in such a way that the risk of injury can be considered to be as low as possible.

8.9.1.2 Testing

This is accomplished by dimensional means.

8.9.2 Gripping power on ice

8.9.2.1 Requirement

The tip shall afford a good grip on ice for groups A and B.

This requirement is fulfilled if the ski-pole does not slip after a 40° rotation from a plane perpendicular to the ice surface resulting in a maximum inclined angle of 50°.

8.9.2.2 Testing

Bring a ski-pole and ice (with a smooth plane surface) to a temperature of -20 °C. Place the ski-pole perpendicularly under a force $-F_z$ of 100 N and, while maintaining this force, rotate it from the perpendicular plane towards the ice surface to an angle of 40°. See Figure 11.

If necessary, the basket may be removed.

Carry out the test within 10 s.

8.9.3 Hardness

8.9.3.1 Requirement

The hardness of the tip shall be at least HRC 50.

8.9.3.2 Testing

Test in accordance with ISO 6508-1, ISO 6508-2 and ISO 6508-3.

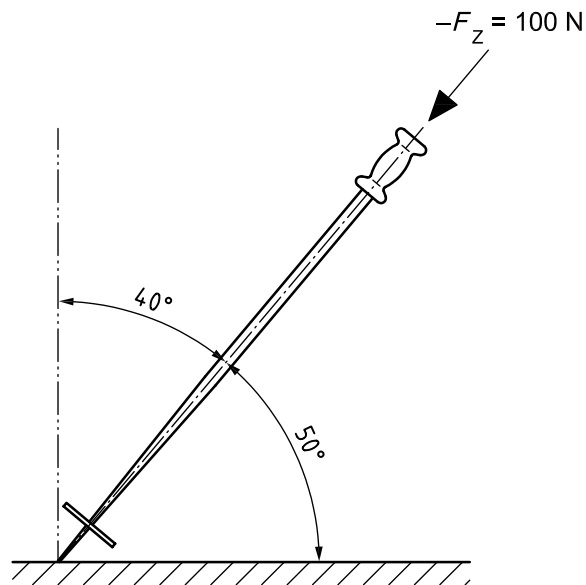

Figure 11 — Test of ice gripping power

9 Marking

9.1 Ski-poles shall be marked with the relevant code letter and the total length l_T in centimetres together with the name or trade-mark of the manufacturer or importer.

9.2 It is the responsibility of the manufacturer to express the correspondence of ski-poles to this International Standard by the additional reference to ISO 7331.

EXAMPLE **A - 130 - ... (manufacturer), or**
 ISO 7331 - A - 130- ... (manufacturer)

.....

ICS 97.220.20

Price based on 17 pages