

---

---

**Rubber and plastics hoses —  
Assessment of ozone resistance under  
static conditions**

*Tuyaux en caoutchouc et en plastique — Évaluation de la résistance à  
l'ozone dans des conditions statiques*



**COPYRIGHT PROTECTED DOCUMENT**

© ISO 2016, Published in Switzerland

All rights reserved. Unless otherwise specified, no part of this publication may be reproduced or utilized otherwise in any form or by any means, electronic or mechanical, including photocopying, or posting on the internet or an intranet, without prior written permission. Permission can be requested from either ISO at the address below or ISO's member body in the country of the requester.

ISO copyright office  
Ch. de Blandonnet 8 • CP 401  
CH-1214 Vernier, Geneva, Switzerland  
Tel. +41 22 749 01 11  
Fax +41 22 749 09 47  
copyright@iso.org  
www.iso.org

# Contents

Page

<b>Foreword</b> .....	<b>iv</b>
<b>Introduction</b> .....	<b>v</b>
<b>1 Scope</b> .....	<b>1</b>
<b>2 Normative references</b> .....	<b>1</b>
<b>3 Terms and definitions</b> .....	<b>1</b>
<b>4 General considerations</b> .....	<b>1</b>
<b>5 Apparatus</b> .....	<b>2</b>
<b>6 Test pieces</b> .....	<b>2</b>
6.1 Type of test piece.....	2
6.1.1 Method 1.....	2
6.1.2 Method 2.....	2
6.1.3 Method 3.....	2
6.1.4 Method 4.....	3
6.1.5 Method 5.....	3
6.2 Number of test pieces.....	3
<b>7 Conditioning of test pieces</b> .....	<b>3</b>
<b>8 Test conditions</b> .....	<b>3</b>
<b>9 Procedure</b> .....	<b>3</b>
9.1 Method 1.....	3
9.2 Method 2.....	4
9.3 Method 3.....	4
9.4 Method 4.....	5
9.5 Method 5.....	6
<b>10 Test report</b> .....	<b>7</b>
<b>Bibliography</b> .....	<b>8</b>

## Foreword

ISO (the International Organization for Standardization) is a worldwide federation of national standards bodies (ISO member bodies). The work of preparing International Standards is normally carried out through ISO technical committees. Each member body interested in a subject for which a technical committee has been established has the right to be represented on that committee. International organizations, governmental and non-governmental, in liaison with ISO, also take part in the work. ISO collaborates closely with the International Electrotechnical Commission (IEC) on all matters of electrotechnical standardization.

The procedures used to develop this document and those intended for its further maintenance are described in the ISO/IEC Directives, Part 1. In particular the different approval criteria needed for the different types of ISO documents should be noted. This document was drafted in accordance with the editorial rules of the ISO/IEC Directives, Part 2 (see [www.iso.org/directives](http://www.iso.org/directives)).

Attention is drawn to the possibility that some of the elements of this document may be the subject of patent rights. ISO shall not be held responsible for identifying any or all such patent rights. Details of any patent rights identified during the development of the document will be in the Introduction and/or on the ISO list of patent declarations received (see [www.iso.org/patents](http://www.iso.org/patents)).

Any trade name used in this document is information given for the convenience of users and does not constitute an endorsement.

For an explanation on the meaning of ISO specific terms and expressions related to conformity assessment, as well as information about ISO's adherence to the World Trade Organization (WTO) principles in the Technical Barriers to Trade (TBT) see the following URL: [www.iso.org/iso/foreword.html](http://www.iso.org/iso/foreword.html).

The committee responsible for this document is ISO/TC 45, *Rubber and rubber products*, Subcommittee SC 1, *Rubber and plastics hoses and hose assemblies*.

This fourth edition cancels and replaces the third edition (ISO 7326:2006), which has been technically revised with the following changes:

- in [Clause 2](#), the latest edition of ISO 1431-1 has been cited;
- [5.5](#) and [9.4.1](#) have been amended;
- in [6.1.1](#), the formula has been amended.

## Introduction

The methods described in this document provide a means of assessing the resistance of hoses to the deleterious effects of atmospheric ozone under static conditions.



# Rubber and plastics hoses — Assessment of ozone resistance under static conditions

## 1 Scope

This document specifies five methods for determining the ozone resistance of the outer covers of hoses:

- method 1, for bore sizes up to and including 25 mm, carried out on the hose itself;
- method 2, for bore sizes greater than 25 mm, carried out on a test piece from the hose wall;
- method 3, for bore sizes greater than 25 mm, carried out on a test piece from the cover;
- method 4, for all bore sizes, carried out on the hose itself;
- method 5, for all bore sizes, carried out on hoses that are expandable, for example textile-reinforced hoses.

**NOTE** For hoses with built-in fittings from which it is not possible to take test pieces, the ozone resistance can be assessed on slabs in accordance with ISO 1431-1, using test sheets of the appropriate polymeric compound vulcanized to the same degree.

## 2 Normative references

The following documents are referred to in the text in such a way that some or all of their content constitutes requirements of this document. For dated references, only the edition cited applies. For undated references, the latest edition of the referenced document (including any amendments) applies.

ISO 1431-1:2012, *Rubber, vulcanized or thermoplastic — Resistance to ozone cracking — Part 1: Static and dynamic strain testing*

ISO 23529, *Rubber — General procedures for preparing and conditioning test pieces for physical test methods*

## 3 Terms and definitions

For the purposes of this document, the terms and definitions given in ISO 8330 apply.

ISO and IEC maintain terminological databases for use in standardization at the following addresses:

- IEC Electropedia: available at <http://www.electropedia.org/>
- ISO Online browsing platform: available at <http://www.iso.org/obp>

## 4 General considerations

Method 1 and method 2 are the methods normally used, method 3 being used only if it is not possible to carry out the test in accordance with method 2. Method 4 is suitable for all bore sizes. Method 5 is specifically for testing expandable hoses in the expanded state.

The results of tests carried out in accordance with method 1 may not be comparable with the results obtained when tests are carried out in accordance with method 2 or method 3, even if the cover compounds of the hoses under test are identical in composition and are cured to the same degree. The test method to be used shall be as specified in the product standard.

## 5 Apparatus

All apparatus placed in the test cabinet shall be fabricated from materials which do not absorb or decompose ozone.

**5.1 Ozone cabinet**, with apparatus for generating ozone, monitoring and controlling the ozone concentration, as described in ISO 1431-1.

**5.2 Test piece holder**, as shown in [Figure 1](#) (for method 1).

**5.3 Test piece holder**, as shown in [Figure 2](#), made, for example, of wood coated with paint or aluminium (for method 2).

**5.4 Jig**, for elongation of test pieces (for method 3).

Details given in ISO 1431-1:2012, 5.6 shall be followed.

**5.5 Cylinder**, as shown in [Figure 3](#), with an outside diameter 2 times that of the specified minimum bend radius for the hose being tested or, if not specified, 8 times the outside diameter (for method 4).

**5.6 Round rod**, as shown in [Figure 4](#), with an outside diameter 1,2 times the inside diameter of the hose being tested (for method 5).

## 6 Test pieces

### 6.1 Type of test piece

#### 6.1.1 Method 1

The test piece shall consist of a hose sample. The length shall be calculated by the following formula:

$$L = \pi \left( r_b + \frac{d_{\text{ext}}}{2} \right) + 2d_{\text{ext}}$$

where

$L$  is the length of the test piece;

$r_b$  is the bend radius of the hose under test, as specified in [9.1.1](#);

$d_{\text{ext}}$  is the outside diameter of the hose under test.

#### 6.1.2 Method 2

The test piece shall consist of a strip cut longitudinally from the hose. The strip shall be 150 mm long and 25 mm wide.

#### 6.1.3 Method 3

The test piece shall consist of a strip of the hose cover, 25 mm in width, removed longitudinally from the hose. Lightly buff the underside of the strip in accordance with ISO 23529 to remove any reinforcement impressions and thus ensure uniformity of strain along the length of the strip.



#### 6.1.4 Method 4

The test piece shall consist of a hose sample long enough to be wound at least once round the cylinder which will be used for the test.

#### 6.1.5 Method 5

The test piece shall consist of a straight length of hose approximately 50 mm long.

### 6.2 Number of test pieces

Three test pieces shall be tested.

## 7 Conditioning of test pieces

No test shall be carried out within 24 h of manufacture.

The time interval between manufacture and testing shall be as specified in ISO 23529. For evaluations which are intended to be comparable, the test shall, as far as possible, be carried out after the same time interval after manufacture.

The test pieces, mounted as described for the appropriate procedure, shall be conditioned for 48 h in a substantially ozone-free atmosphere at standard temperature (see ISO 23529), in darkness or subdued light.

## 8 Test conditions

Unless other conditions are specified in the relevant hose specification, the test pieces shall be exposed in the ozone cabinet to an ozone concentration of  $(50 \pm 5)$  pphm (parts per hundred million) by volume at  $(40 \pm 2)$  °C for  $(72_{-2}^0)$  h.

**NOTE** It has been found that differences in atmospheric pressure can influence ozone cracking when test pieces are exposed to constant ozone concentrations expressed in parts per hundred million. This effect may be taken into account by expressing the ozone content in the ozonized air in terms of the partial pressure, i.e. in millipascals, and making comparisons at constant ozone partial pressure. At standard conditions of atmospheric pressure and temperature (101 kPa, 273 K), a concentration of 1 pphm is equivalent to a partial pressure of 1,01 mPa.

## 9 Procedure

### 9.1 Method 1

**9.1.1** Mount each test piece on a test piece holder (5.2), as shown in Figure 1. The radius,  $r_b$ , shall be equal to the specified minimum bend radius for the hose under test or, if not specified, 6 times the internal diameter.

**9.1.2** Seal the ends of the test pieces with caps to prevent absorption of ozone by the inner lining and reinforcement.

9.1.3 After periods of exposure of 2 h, 4 h, 24 h, 48 h and 72 h, examine the test pieces, whilst still in the extended condition, under  $\times 2$  magnification, ignoring the area adjacent to the fixing points. If cracks are discovered, record their nature and the time at which they were first observed.

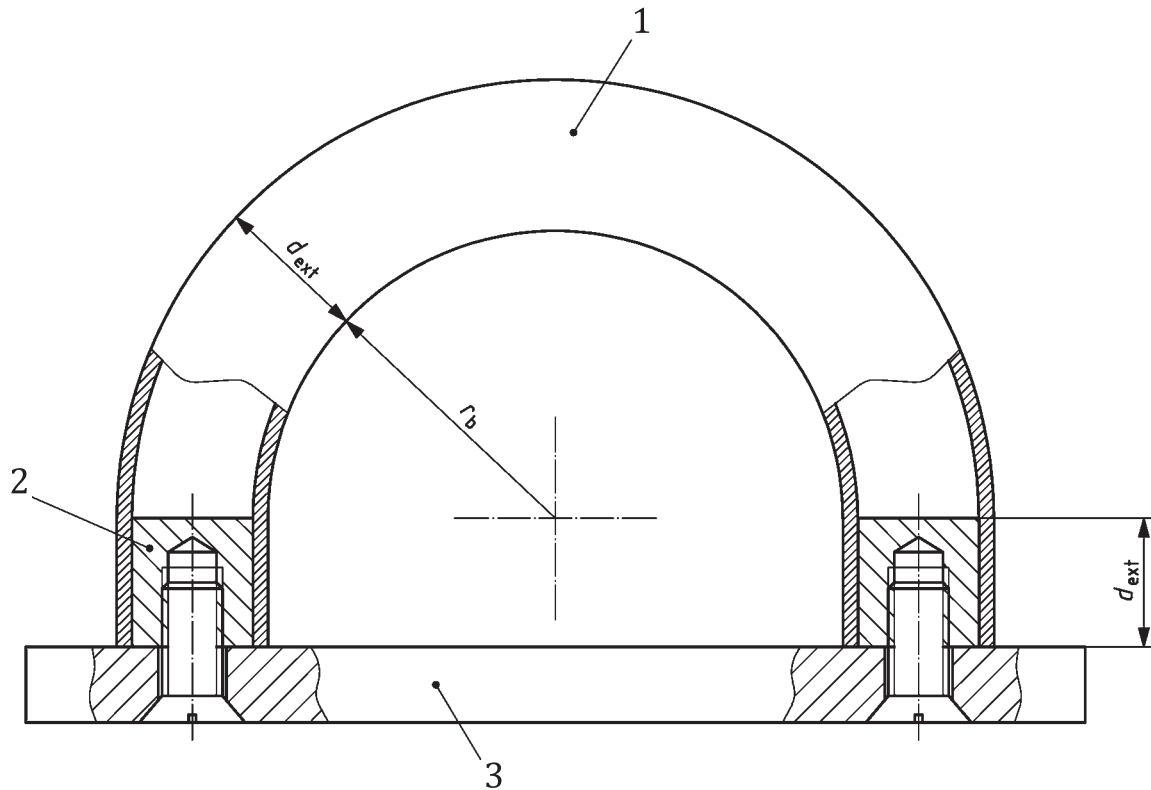

**Key**

- 1 hose test piece  $\left[ L = \pi \left( r_b + \frac{d_{ext}}{2} \right) + 2d_{ext} \right]$
- 2 aluminium plug
- 3 aluminium baseplate

**Figure 1 — Arrangement for mounting hose for method 1**

**9.2 Method 2**

9.2.1 Mount each test piece on a test piece holder (5.3), as shown in Figure 2, so that the required elongation of the hose cover, measured over a distance of 20 mm, is reached. If not otherwise specified, the elongation of the cover shall be 20 %. Coat the edge and the lining of each test piece with an ozone-resistant lacquer.

9.2.2 After periods of exposure of 2 h, 4 h, 24 h, 48 h and 72 h, examine the test pieces, whilst still in the extended condition, under  $\times 2$  magnification, ignoring the area adjacent to the fixing points. If cracks are discovered, record their nature and the time at which they were first observed.

**9.3 Method 3**

9.3.1 Mount each test piece in a jig (5.4) and apply 20 % elongation.

**9.3.2** After periods of exposure of 2 h, 4 h, 24 h, 48 h and 72 h, examine the test pieces, whilst still in the extended condition, under  $\times 2$  magnification, ignoring the area adjacent to the fixing points. If cracks are discovered, record their nature and the time at which they were first observed.

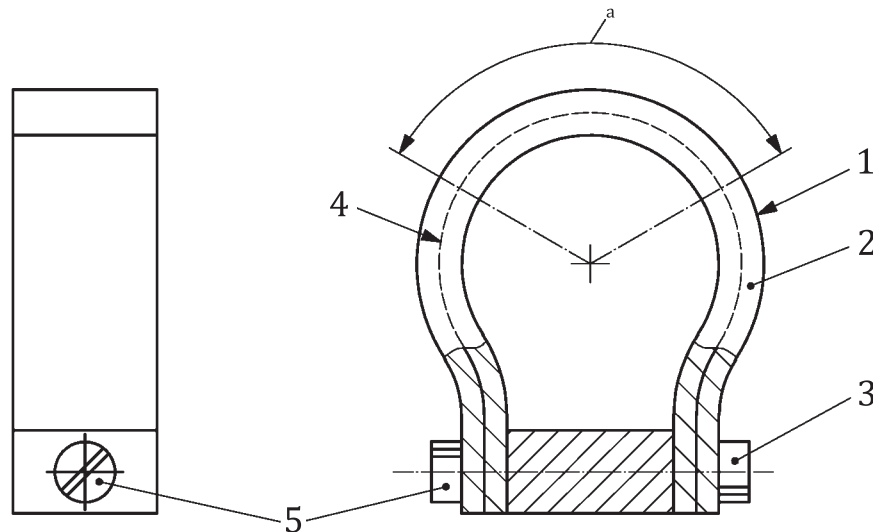

**Key**

- 1 outside surface of hose
- 2 test strip (end-to-end length = 150 mm)
- 3 grip
- 4 hose reinforcement
- 5 retaining bolt
- a Measurement distance.

**Figure 2 — Test pieces mounted on holder for method 2**

**9.4 Method 4**

**9.4.1** Wind each test piece on a cylinder with an outside diameter 2 times of that of the specified minimum bend radius for the hose or, if not specified, 8 times the outside diameter, as shown in [Figure 3](#).

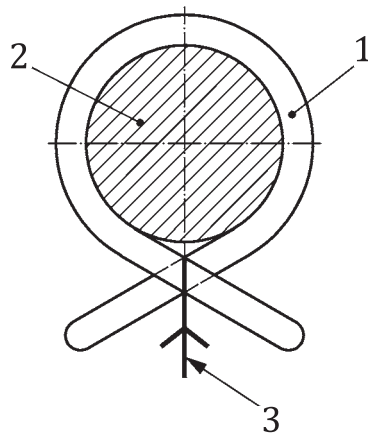

**Key**

- 1 test piece
- 2 cylinder
- 3 e.g. wire or cord to hold ends of test piece together

**Figure 3 — Test piece wound on cylinder (method 4)**

9.4.2 After periods of exposure of 2 h, 4 h, 24 h, 48 h and 72 h, examine the test pieces under  $\times 2$  magnification, ignoring the area where the ends of the test piece were tied together. If cracks are discovered, record their nature and the time at which they were first observed.

**9.5 Method 5**

9.5.1 Insert a round rod of outside diameter 1,2 times the inside diameter of the hose into each test piece, as shown in [Figure 4](#).

Dimensions in millimetres

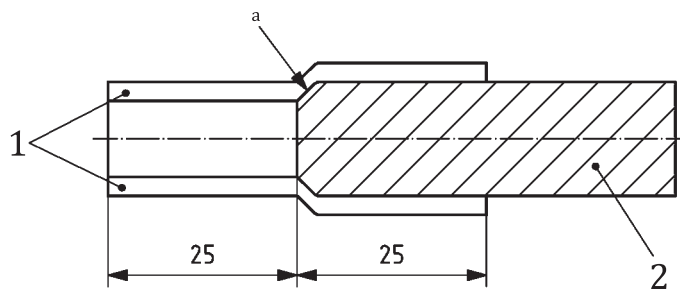

**Key**

- 1 test piece
- 2 round rod
- a End of rod has rounded edge.

**Figure 4 — Round rod inserted in test piece (method 5)**

9.5.2 After periods of exposure of 2 h, 4 h, 24 h, 48 h and 72 h, examine both ends and the outer cover of the test pieces under  $\times 2$  magnification. If cracks are discovered, record their nature and the time at which they were first observed.

## 10 Test report

The test report shall include the following information:

- a) a reference to this document, i.e. ISO 7326:2016;
- b) a full description of the hose tested;
- c) the method used (method 1, 2, 3, 4 or 5);
- d) the details of the test conditions, i.e. ozone concentration, temperature, exposure period and elongation, as applicable;
- e) whether cracks were observed and, if so, their nature and the time the cracks were first observed;
- f) the date of test.

## Bibliography

ISO 8330, *Rubber and plastics hoses and hose assemblies — Vocabulary*



