

---

---

**Diesel engines — End-mounting flanges  
for pumps —**

Part 2:

**High-pressure supply pumps for common  
rail fuel injection systems**

*Moteurs diesels — Brides de montage des pompes —*

*Partie 2: Pompes d'alimentation à haute pression pour systèmes  
d'injection de combustible à rampe commune*



**PDF disclaimer**

This PDF file may contain embedded typefaces. In accordance with Adobe's licensing policy, this file may be printed or viewed but shall not be edited unless the typefaces which are embedded are licensed to and installed on the computer performing the editing. In downloading this file, parties accept therein the responsibility of not infringing Adobe's licensing policy. The ISO Central Secretariat accepts no liability in this area.

Adobe is a trademark of Adobe Systems Incorporated.

Details of the software products used to create this PDF file can be found in the General Info relative to the file; the PDF-creation parameters were optimized for printing. Every care has been taken to ensure that the file is suitable for use by ISO member bodies. In the unlikely event that a problem relating to it is found, please inform the Central Secretariat at the address given below.



**COPYRIGHT PROTECTED DOCUMENT**

© ISO 2009

All rights reserved. Unless otherwise specified, no part of this publication may be reproduced or utilized in any form or by any means, electronic or mechanical, including photocopying and microfilm, without permission in writing from either ISO at the address below or ISO's member body in the country of the requester.

ISO copyright office  
Case postale 56 • CH-1211 Geneva 20  
Tel. + 41 22 749 01 11  
Fax + 41 22 749 09 47  
E-mail [copyright@iso.org](mailto:copyright@iso.org)  
Web [www.iso.org](http://www.iso.org)

Published in Switzerland

## Foreword

ISO (the International Organization for Standardization) is a worldwide federation of national standards bodies (ISO member bodies). The work of preparing International Standards is normally carried out through ISO technical committees. Each member body interested in a subject for which a technical committee has been established has the right to be represented on that committee. International organizations, governmental and non-governmental, in liaison with ISO, also take part in the work. ISO collaborates closely with the International Electrotechnical Commission (IEC) on all matters of electrotechnical standardization.

International Standards are drafted in accordance with the rules given in the ISO/IEC Directives, Part 2.

The main task of technical committees is to prepare International Standards. Draft International Standards adopted by the technical committees are circulated to the member bodies for voting. Publication as an International Standard requires approval by at least 75 % of the member bodies casting a vote.

Attention is drawn to the possibility that some of the elements of this document may be the subject of patent rights. ISO shall not be held responsible for identifying any or all such patent rights.

ISO 7299-2 was prepared by Technical Committee ISO/TC 22, *Road vehicles*, Subcommittee SC 7, *Injection equipment and filters for use on road vehicles*.

This first edition of ISO 7299-2, together with ISO 7299-1:2007, cancels and replaces ISO 7299:1996, which has been technically revised.

ISO 7299 consists of the following parts, under the general title *Diesel engines — End-mounting flanges for pumps*:

- *Part 1: Fuel injection pumps*
- *Part 2: High-pressure supply pumps for common rail fuel injection systems*



# Diesel engines — End-mounting flanges for pumps —

## Part 2: High-pressure supply pumps for common rail fuel injection systems

### 1 Scope

This part of ISO 7299 specifies dimensional requirements for seven types of end-mounting flanges of high-pressure supply pumps for common rail fuel injection systems for use in diesel (compression-ignition) engines.

### 2 Normative references

The following referenced documents are indispensable for the application of this document. For dated references, only the edition cited applies. For undated references, the latest edition of the referenced document (including any amendments) applies.

ISO 6519, *Diesel engines — Fuel injection pumps — Tapers for shaft ends and hubs*

### 3 Dimensions and tolerances

#### 3.1 General

Engine manufacturers should use the tolerance H7 for the female register diameter.

In the figures and tables, except for Figures 2 and 5 and Tables 2 and 5 (shaft end with tang drive), the diameter  $d_2$  corresponds to the diameter  $d$  specified in ISO 6519.

NOTE The flange configuration can optionally be rotated relative to the pump housing.

### 3.2 High-pressure supply pumps

#### 3.2.1 Type 1 end-mounting flange

See Figure 1 and Table 1.

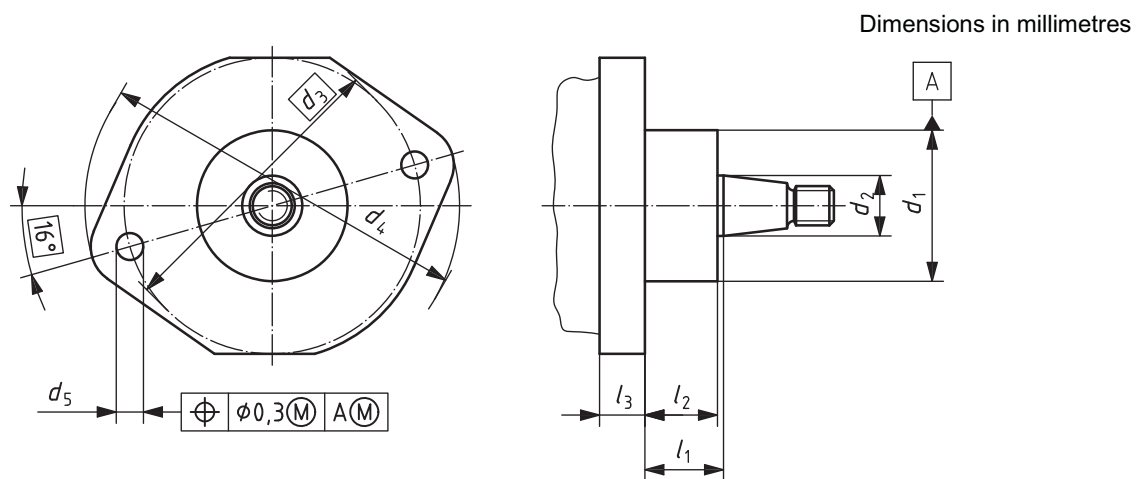

Figure 1

Table 1

Dimensions in millimetres

$d_1$ f7	$d_2$ nom.	$d_3$ nom.	$d_4$ max.	$d_5$	$l_1$ $\pm 0,5$	$l_2$		$l_3$ nom.
						min.	max.	
$\varnothing 50$	$\varnothing 20$	$\varnothing 98$	$\varnothing 125$	$\varnothing 8,5$ to $9,3$	26	23,5	24,5	15

3.2.2 Type 2 end-mounting flange (with tang drive)

See Figure 2 and Table 2.

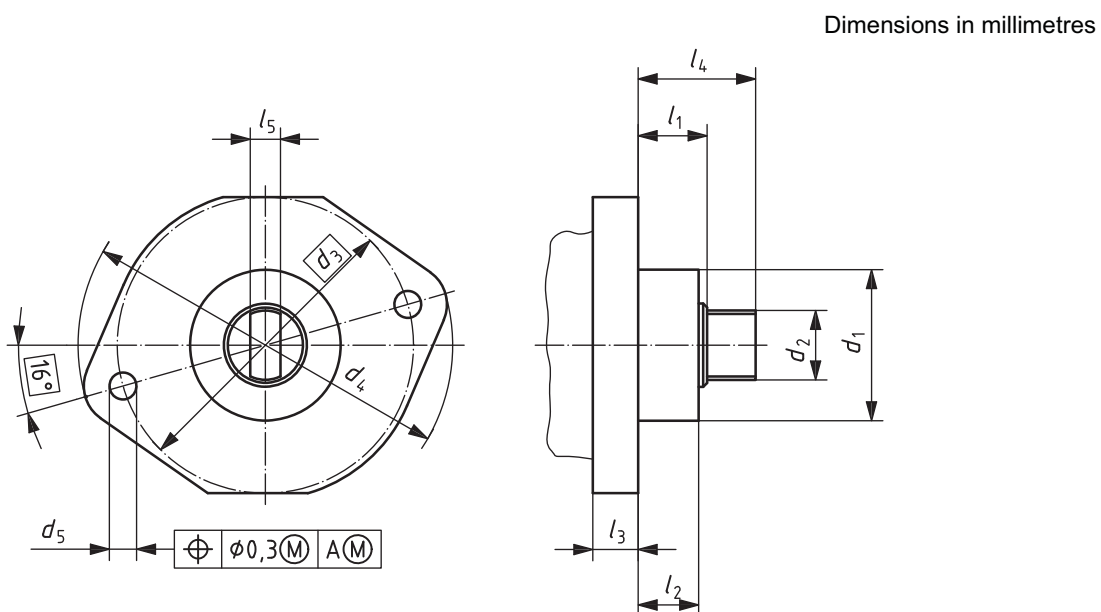

Figure 2

Table 2

Dimensions in millimetres

$d_1$	$d_2$	$d_3$	$d_4$	$d_5$	$l_1$	$l_2$	$l_3$	$l_4$	$l_5$
f7	nom.	nom.	max.		$\pm 1$	max.	nom.	$\pm 1$	f7
$\varnothing 50$	$\varnothing 23$	$\varnothing 98$	$\varnothing 125$	$\varnothing 8,5$ to $9,3$	21,8	20,7	15	38,9	10

3.2.3 Type 3 end-mounting flange

See Figure 3 and Table 3.

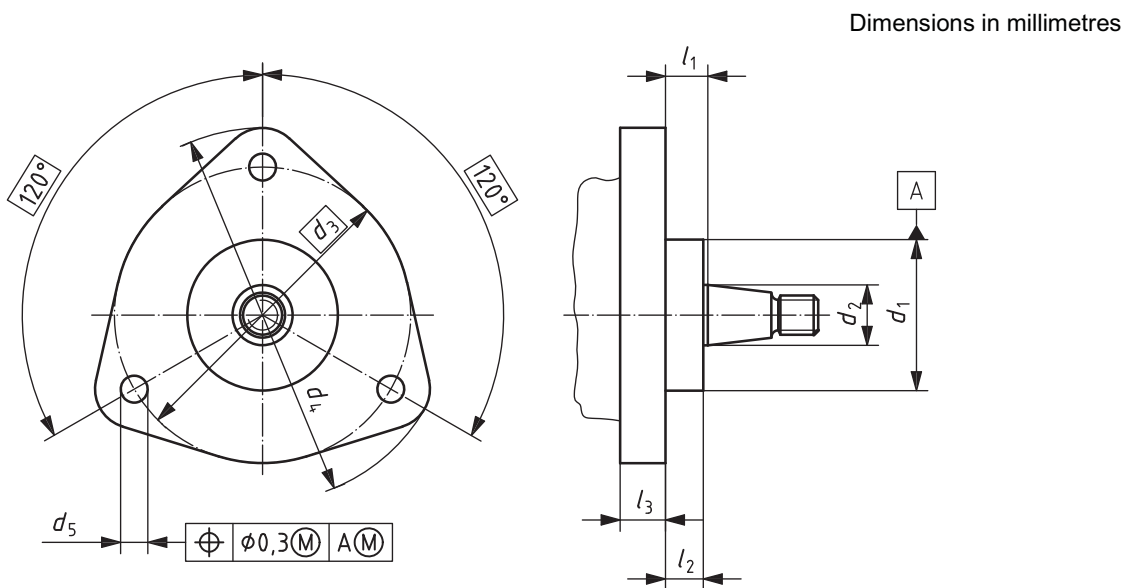

Figure 3

Table 3

Dimensions in millimetres

$d_1$ f7	$d_2$ nom.	$d_3$ nom.	$d_4$ max.	$d_5$		$l_1$ $\pm 0,5$	$l_2$		$l_3$ nom.
				drilled	threaded <sup>a</sup>		min.	max.	
$\varnothing 50$	$\varnothing 20$	$\varnothing 98$	$\varnothing 125$	$\varnothing 8,5$ to $9,3$	—	14	12	13	15
$\varnothing 68$		$\varnothing 90$	$\varnothing 116$	$\varnothing 8,5$ to $9,3$	M8 $\times$ 1,25 – 6H	25,7	18	24	15 or 17

<sup>a</sup> Optional.



3.2.4 Type 4 end-mounting flange

See Figure 4 and Table 4.

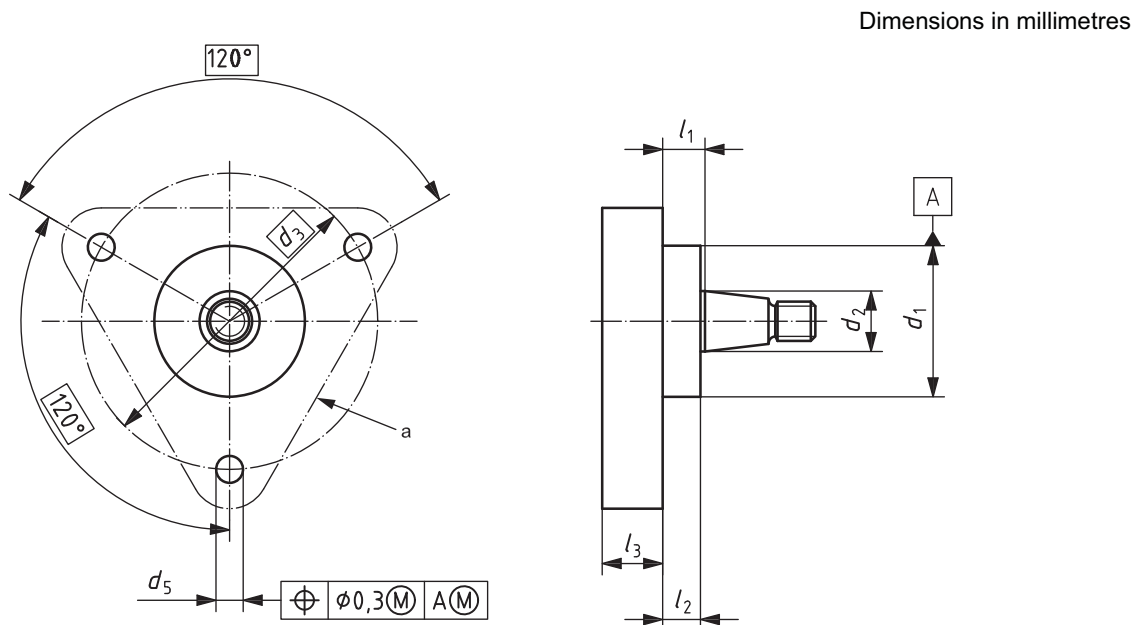

<sup>a</sup> This figure shows requirements for the position of the three mounting holes. The actual configuration of the flange depends on design requirements.

Figure 4

Table 4

Dimensions in millimetres

$d_1$ f7	$d_2$ nom.	$d_3$ nom.	$d_5$		$l_1$ nom.	$l_2$	$l_3$ nom.
			drilled (nom.)	threaded <sup>a</sup>			
∅ 50 or 68	∅ 20, 22 or 25	∅ 98	∅ 8,5 to 9,4	M8 × 1,25 – 6H	12 to 14	13 max.	11 to 27
∅ 68 or 80	∅ 25				∅ 10,5	22 to 26,5	
∅ 107		∅ 130	12 to 26,5		10,2 to 24,5		
<sup>a</sup> Optional.							

3.2.5 Type 5 end-mounting flange (with tang drive)

See Figure 5 and Table 5.

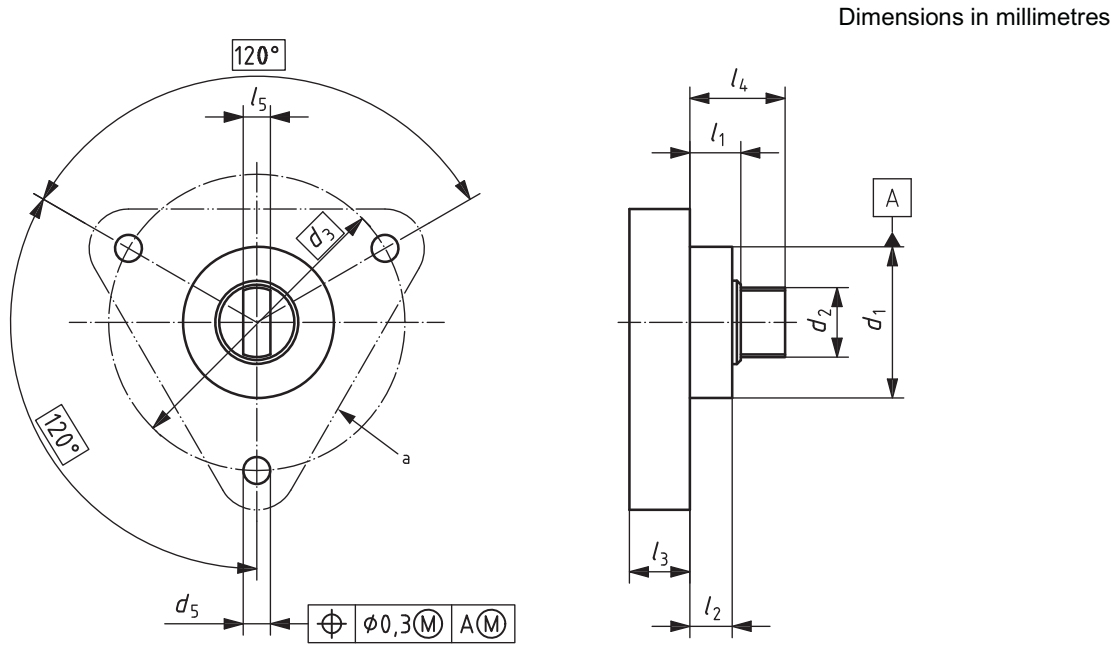

<sup>a</sup> This figure shows requirements for the position of the three mounting holes. The actual configuration of the flange depends on design requirements.

Figure 5

Table 5

Dimensions in millimetres

$d_1$	$d_2$	$d_3$	$d_5$		$l_1$	$l_2$	$l_3$	$l_4$	$l_5$
f7	nom.	nom.	drilled (nom.)	threaded <sup>a</sup>	nom.	max.	nom.	nom.	f7
Ø 50	Ø 20	Ø 98	Ø 9,4	M6 × 1 – 6H	16,85	14,1	19 to 24,5	31,5	9
	Ø 20, 22 or 25		Ø 8,5 to 9,4	M8 × 1,25 – 6H	21,3 to 23	21,1			8
		Ø 7,8	7,3						

<sup>a</sup> Optional.

3.2.6 Type 6 end-mounting flange

See Figure 6 and Table 6.

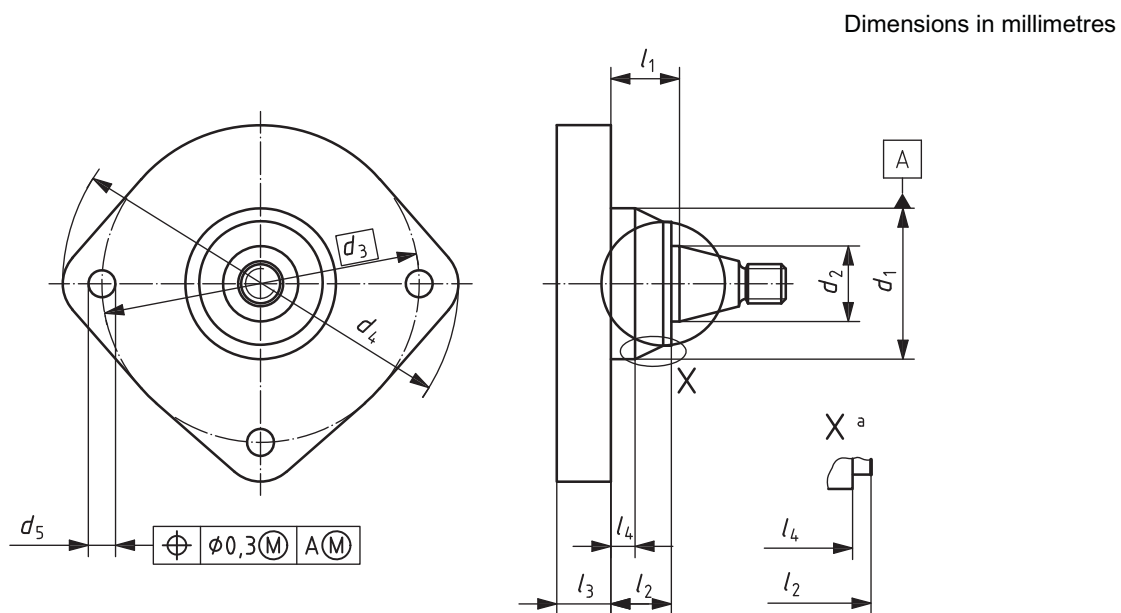

<sup>a</sup> Detail X (optional).

Figure 6

Table 6

Dimensions in millimetres

$d_1$		$d_2$ nom.	$d_3$ nom.	$d_4$ max.	$d_5$ H13	$l_1$ $\pm 0,6$	$l_2$		$l_3$ nom.	$l_4$	
							min.	max.		min.	max.
$\varnothing 50$	-0,019 -0,065	$\varnothing 25$	$\varnothing 105$	$\varnothing 131$	$\varnothing 9$	21,35	19,25	20,45	17,9	6,65	8,65
	-0,024 -0,070										
	-0,019 -0,065					11,05	9,25	9,85		2,5	3,5
	21,35										

3.2.7 Type 7 end-mounting flange

See Figure 7 and Table 7.

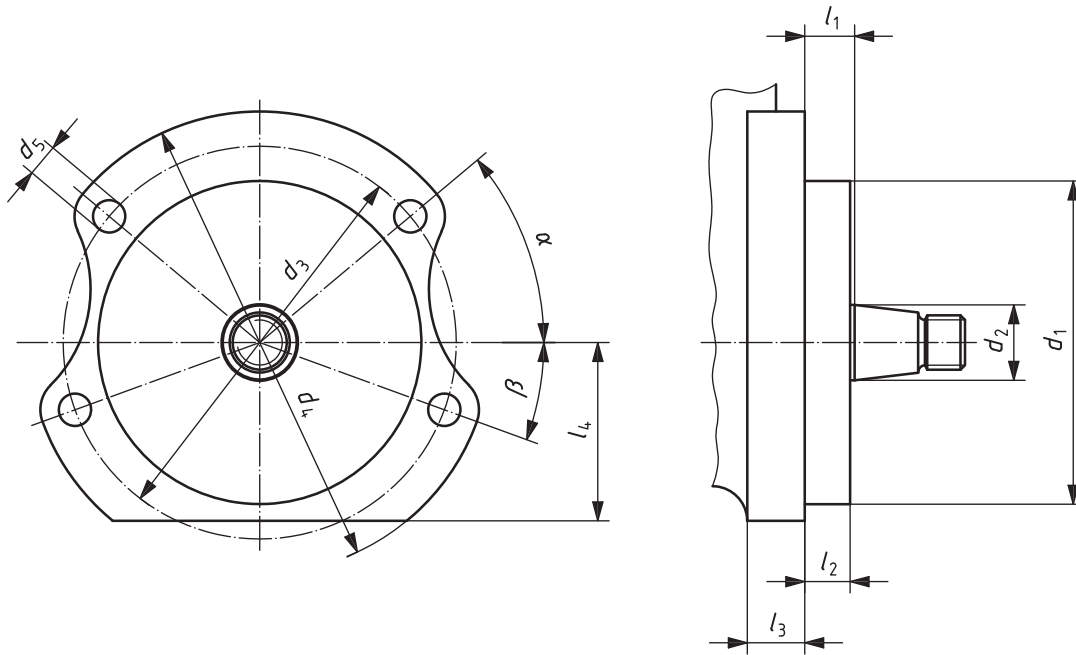

Figure 7

Table 7

Dimensions in millimetres  
Angles in degrees

$d_1$ f7	$d_2$ nom.	$d_3$ $\pm 0,3$	$d_4$ max.	$d_5$	$l_1$	$l_2$		$l_3$ nom.	$l_4$ nom.	$\alpha$ $\pm 0,5$	$\beta$ $\pm 0,5$
						min.	max.				
$\varnothing 107$	$\varnothing 25$	$\varnothing 130$	$\varnothing 155,4$	$\varnothing 10,7$ to $10,9$	16,2 to 16,8	14,5	15,7	19	59	40	20
	13,2 to 13,8				10,5	12,0	45			30	
	$\varnothing 30$			$\varnothing 10,5$ to $10,8$	12,9 to 14,2	11,4	11,8	18	62	40	20
	$\varnothing 30$ or $35$				56	45	30				
$\varnothing 35$											

## Bibliography

- [1] ISO 261, *ISO general purpose metric screw threads — General plan*
- [2] ISO 286-2, *ISO system of limits and fits — Part 2: Tables of standard tolerance grades and limit deviations for holes and shafts*
- [3] ISO 965-1, *ISO general-purpose metric screw threads — Tolerances — Part 1: Principles and basic data*

