

Second edition
1988-04-07

AMENDMENT 1
2014-03-01

**Tyre valves for aircraft —
Interchangeability dimensions**

AMENDMENT 1

*Valves pour pneumatiques d'aéronefs — Dimensions
d'interchangeabilité*

AMENDEMENT 1



Reference number
ISO 7295:1988/Amd.1:2014(E)

© ISO 2014



COPYRIGHT PROTECTED DOCUMENT

© ISO 2014

All rights reserved. Unless otherwise specified, no part of this publication may be reproduced or utilized otherwise in any form or by any means, electronic or mechanical, including photocopying, or posting on the internet or an intranet, without prior written permission. Permission can be requested from either ISO at the address below or ISO's member body in the country of the requester.

ISO copyright office
Case postale 56 • CH-1211 Geneva 20
Tel. + 41 22 749 01 11
Fax + 41 22 749 09 47
E-mail copyright@iso.org
Web www.iso.org

Published in Switzerland

Foreword

ISO (the International Organization for Standardization) is a worldwide federation of national standards bodies (ISO member bodies). The work of preparing International Standards is normally carried out through ISO technical committees. Each member body interested in a subject for which a technical committee has been established has the right to be represented on that committee. International organizations, governmental and non-governmental, in liaison with ISO, also take part in the work. ISO collaborates closely with the International Electrotechnical Commission (IEC) on all matters of electrotechnical standardization.

The procedures used to develop this document and those intended for its further maintenance are described in the ISO/IEC Directives, Part 1. In particular the different approval criteria needed for the different types of ISO documents should be noted. This document was drafted in accordance with the editorial rules of the ISO/IEC Directives, Part 2 (see www.iso.org/directives).

Attention is drawn to the possibility that some of the elements of this document may be the subject of patent rights. ISO shall not be held responsible for identifying any or all such patent rights. Details of any patent rights identified during the development of the document will be in the Introduction and/or on the ISO list of patent declarations received (see www.iso.org/patents).

Any trade name used in this document is information given for the convenience of users and does not constitute an endorsement.

For an explanation on the meaning of ISO specific terms and expressions related to conformity assessment, as well as information about ISO's adherence to the WTO principles in the Technical Barriers to Trade (TBT) see the following URL: Foreword - Supplementary information

The committee responsible for this document is ISO/TC 31, *Tyres, rims and valves*, Subcommittee SC 9, *Valves for tube and tubeless tyres*.

Tyre valves for aircraft — Interchangeability dimensions

AMENDMENT 1

Page 3, Figure 4

Replace the current Figure 4 with the following:

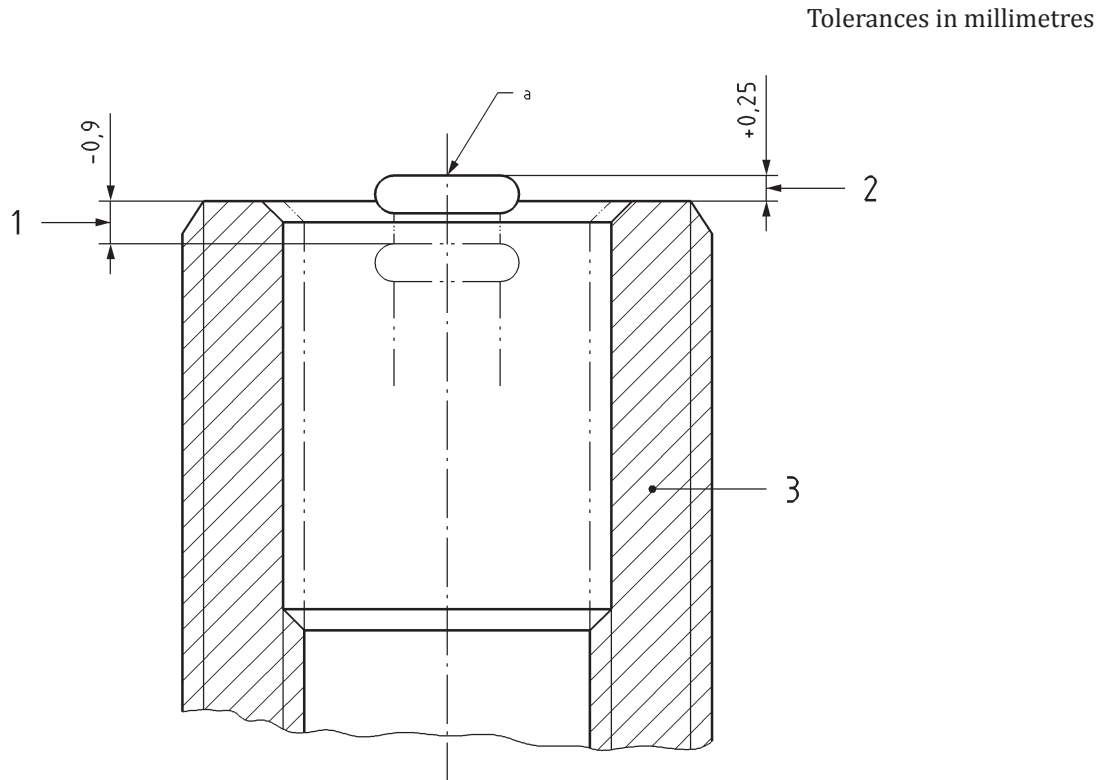

Key

- 1 low limit
- 2 high limit
- 3 valve stem
- a The pin head shall not be more than 0,25 mm above or 0,9 mm below the valve mouth after inserting the core at a torque of:
 - 0,23 – 0,56 N·m for a core with an elastomeric barrel gasket;
 - 0,40 – 0,50 N·m for a core with a metallic sealing gasket.

Figure 4 — Core pin head position — Tolerances

