**Liquid hydrocarbons — Dynamic
measurement — Proving systems for
volumetric meters —**

Part 4:
Guide for operators of pipe provers

*Hydrocarbures liquides — Mesurage dynamique — Systèmes d'étalonnage
des compteurs volumétriques —*

Partie 4: Manuel de référence pour les opérateurs de tubes étalons



Contents

1 Scope	1
2 Normative references	1
3 Principles	1
3.1 Ways of expressing a meter's performance	1
3.2 How meter performance varies	3
3.3 Correction factors	4
4 Meters and provers	5
4.1 Pulse-generating meters	5
4.2 Sources of error in operating meters	5
4.3 Pulse interpolators	6
4.4 Conventional pipe provers	7
4.5 Small volume pipe provers	10
4.6 Methods of installing pipe provers	12
4.7 Sources of error in operating pipe provers	13
4.8 Prover calibration and recalibration	14
4.9 Meter installations	14
5 Safety requirements	16
5.1 General	16
5.2 Permits	17
5.3 Mechanical safety	17
5.4 Electrical safety	19
5.5 Fire precautions	20
5.6 Miscellaneous safety precautions	20
5.7 Records	21

© ISO 1999

All rights reserved. Unless otherwise specified, no part of this publication may be reproduced or utilized in any form or by any means, electronic or mechanical, including photocopying and microfilm, without permission in writing from the publisher.

International Organization for Standardization
Case postale 56 • CH-1211 Genève 20 • Switzerland
Internet iso@iso.ch

Printed in Switzerland

6 Operating a pipe prover 21

6.1 Setting up a portable prover 21

6.2 Warming up provers 22

6.3 Periodical checks of factors affecting accuracy 22

6.4 The actual proving operation 22

6.5 Assessment of the results 23

6.6 Fault finding 23

Annex A (informative) Bibliography 27

Foreword

ISO (the International Organization for Standardization) is a worldwide federation of national standards bodies (ISO member bodies). The work of preparing International Standards is normally carried out through ISO technical committees. Each member body interested in a subject for which a technical committee has been established has the right to be represented on that committee. International organizations, governmental and non-governmental, in liaison with ISO, also take part in the work. ISO collaborates closely with the International Electrotechnical Commission (IEC) on all matters of electrotechnical standardization.

Draft International Standards adopted by the technical committees are circulated to the member bodies for voting. Publication as an International Standard requires approval by at least 75 % of the member bodies casting a vote.

International Standard ISO 7278-4 was prepared by Technical Committee ISO/TC 28, *Petroleum products and lubricants*, Subcommittee SC 2, *Dynamic petroleum measurement*.

ISO 7278 consists of the following parts, under the general title *Liquid hydrocarbons — Dynamic measurement — Proving systems for volumetric meters*:

- *Part 1: General principles*
- *Part 2: Pipe provers*
- *Part 3: Pulse interpolation techniques*
- *Part 4: Guide for operators of pipe provers*
- *Part 5: Small volume provers*

Annex A of this part of ISO 7278 is for information only.

Introduction

All measuring instruments which have to meet a standard of accuracy need periodic calibration – that is to say, a test or series of tests has to be performed in which readings obtained from the instrument are compared with independent measurements of higher accuracy. Petroleum meters are no exception. Nearly all those used for the purpose of selling or assessing taxes, by national laws, need proving at intervals, and when there is a large amount of money at stake they are likely to be calibrated quite frequently. In the petroleum industry the term 'proving' is used to describe the procedure of calibrating volume meters on crude oil and petroleum products.

The most usual way to prove a meter is to pass a quantity of liquid through it into an accurate device for measuring volume, known as a prover. With very small meters the proving device may be a volumetric flask or similarly shaped vessel of metal with an accurately known volume. There are, for instance, standard measuring vessels which can be used to prove the meters incorporated in gasoline dispensing pumps at roadside filling stations. If the pump dial registers 10,2 litres when enough gasoline has been delivered to fill a 10 litre vessel, it is evident that the meter is over-reading by 2 %.

In a large metering installation, where a single meter can be passing thousands of litres per second, the situation is much more complicated. The measuring elements of the meters generally do not drive mechanical dials graduated in units of volume like a gasoline dispenser, but instead cause a series of electrical pulses to be generated which are registered by electrical counters. With meters of this type the purpose of proving is to determine the relationship between the number of pulses generated/counted and the volume passed through the meter – a relationship which varies with the design and size of the meter and can be affected by flowrate and liquid properties.

Another difficulty is that where the meters are in a pipeline the flow through these large meters usually cannot be stopped and started at will. Consequently, both the meters and the prover have to be capable of being read simultaneously and 'on the fly', that is, while liquid is passing through them at a full flowrate. The proving is complicated still further by the effects of thermal expansion and compressibility on the oil, and that of thermal expansion and elastic distortion under pressure on the steel body of the prover.

This part of ISO 7278 is concerned with only one class of provers, known as pipe provers, which are used very widely where meters for crude oil and petroleum products have to be proved to the highest possible standards of accuracy. In principle, a pipe prover is only a length of pipe or a cylinder whose internal volume has been measured very accurately and having a well-fitted piston (or a tightly-fitted sphere acting like a piston) inside it, so that the volume swept out by the piston or sphere can be compared with the meter readout while a steady flow of liquid is passing through the meter and prover in series. In practice, however, various accessories must be added to the simple pipe-and-piston arrangement to produce a prover that will work effectively.

© 2010 ISO

Liquid hydrocarbons — Dynamic measurement — Proving systems for volumetric meters —

Part 4: Guide for operators of pipe provers

1 Scope

This part of ISO 7278 provides guidance on operating pipe provers to prove turbine meters and displacement meters. It applies both to the types of pipe prover specified in ISO 7278-2, which are referred to here as “conventional pipe provers”, and to other types referred to here as “compact pipe provers” or “small volume provers”.

It is intended for use as a reference manual for the operation of pipe provers, and also for use in staff training. It does not cover the detailed differences between provers of broadly similar types made by different manufacturers.

2 Normative references

The following standards contain provisions which, through reference in this text, constitute provisions of this part of ISO 7278. At the time of publication, the editions indicated were valid. All standards are subject to revision, and parties to agreements based on this part of ISO 7278 are encouraged to investigate the possibility of applying the most recent editions of the International Standards indicated below. Members of IEC and ISO maintain registers of currently valid International Standards.

ISO 2714:1980, *Liquid hydrocarbons — Volumetric measurement by displacement meter systems other than dispensing pumps.*

ISO 2715:1981, *Liquid hydrocarbons — Volumetric measurement by turbine meter systems.*

ISO 4124:1994, *Liquid hydrocarbons — Dynamic measurement — Statistical control of volumetric metering systems.*

ISO 4267-2:1988, *Petroleum and liquid petroleum products — Calculation of oil quantities — Part 2: Dynamic measurement.*

ISO 7278-2:1988, *Liquid hydrocarbons — Dynamic measurement — Proving systems for volumetric meters — Part 2: Pipe provers.*

ISO 7278-3:1998, *Liquid hydrocarbons — Dynamic measurement — Proving systems for volumetric meters — Part 3: Pulse interpolation techniques.*

3 Principles

3.1 Ways of expressing a meter's performance

The object of proving meters with a pipe prover is to provide a number with (usually) four or five significant digits – such as 1,002 9, 0,999 8, or 21 586 which can afterwards be used to convert the readout of the meter into an accurate value of the volume passed through the meter.

There are several different forms that this numerical expression of a meter's performance can take, but only three of them are of importance to the pipe prover operator. They are discussed below.

3.1.1 Meter factor

The earliest petroleum meters were of the displacement type (see 4.1) with dials reading directly in units of volume such as litres or cubic metres. Readings on the display are usually approximate values. These values may be corrected to reflect a more accurate number by either changing the gear ratio in the display mechanism or through the use of a meter factor. Since difficulty can arise in attempting to achieve a given volume through changing the gears, the meter factor is more commonly used.

The meter factor, MF, is defined as the ratio of the actual volume of liquid passed through the meter (V) to the volume indicated on the dial of the meter (V_m). That is:

$$MF = V/V_m \quad (1)$$

In a proving operation the value of V is derived from the prover while V_m is read directly from the meter. Afterwards, when the meter is being used to measure throughput, readings can be multiplied by MF to give the corrected values of the volumes delivered.

Meter factor is a non-dimensional quantity, a pure number. This means that its value does not vary with a change in units used to measure volume.

3.1.2 K factor

During the past quarter of a century, turbine meters (see 4.1) have come into widespread use in the petroleum industry. They do not usually have a dial reading in units of volume, because their primary readout is simply a train of electrical pulses. These are collected in an electronic counter, and the number of pulses counted (n) is proportional to the volume passed by the meter.

The object of proving such a meter is to establish the relationship between n and V . One way of expressing this relationship is through a quantity called K factor, which is defined as the number of pulses emitted by the meter while one unit volume is delivered. That is:

$$K = n/V \quad (2)$$

When a meter is being proved it is necessary to obtain simultaneous values of n and V , with n coming from the meter and V from the prover. In subsequent use of the meter, the procedure is to *divide* the K factor into the number of pulses emitted by the meter in order to obtain the volume delivered.

The K factor is not a pure number. It has the dimensions of reciprocal volume ($1/V$) and so its value depends upon the units used to measure volume. A value of K factor expressed as pulses per cubic metre, for instance, is a thousand times the value expressed as pulses per litre.

3.1.3 One pulse volume

Because it is easier to multiply than to divide, the reciprocal of the K factor is a more useful quantity for field use when hand calculations are employed (but not when computers are used). This reciprocal is called the "one-pulse volume" (q) because it indicates the volume delivered by the meter (on average) while one pulse is emitted. It is defined by the equation:

$$q = 1/K = V/n \quad (3)$$

q has the dimensions of volume per pulse. When it is multiplied by the number of pulses emitted by the meter, the result is the volume delivered through the meter.

3.1.4 Alternative uses of meter factor, K factor and one pulse volume

It is shown in the previous subclauses how meter factor was originally used with displacement meters. With readout in units of volume, K factor and its reciprocal q are used with turbine meters, with the readout being a number indicated on a pulse-counter. Nowadays however, this distinction has largely disappeared. On the one hand, displacement meters intended for use with pipe provers are always fitted with electrical pulse-generators, so that for the purposes of proving they behave like turbine meters and the results can be expressed as a value of K factor or one pulse volume. On the other hand, some modern large-scale turbine metering systems incorporate a data processing module, sometimes known as a “scaler”, which converts the number of pulses emitted into a nominal value of the volume delivered; with such systems the earlier notion of meter factor again becomes useful in certain circumstances.

Detailed instructions for the use of meter factor, K factor and one pulse volume are given in ISO 4267-2.

3.2 How meter performance varies

Manufacturers' literature often states that the K factor of a certain meter is such-and-such, as if it were a constant value. But this is only approximately correct. K factor is affected to some extent by a number of variables, some of which are considered in 3.2.1 to 3.2.6.

3.2.1 Effect of flowrate

Meters are designed so that their factors are almost constant over a fairly wide range of flowrates. The ratio between flowrates at the top and bottom of this range is called the “rangeability”, or the “turndown ratio”, of the meter. Rangeabilities of the turbine and displacement meters widely used for hydrocarbon measurement generally do not exceed ten to one although some special meters may have considerably greater rangeabilities. Within this effective working range the K factor should not vary from its mean value by more than a small amount, and the extent to which it actually does vary – such as $\pm 0,25\%$ or $\pm 0,5\%$ — is known as the “linearity” of the meter. When complete information about the meter's performance is needed it has to be proved at several different flowrates, so that its rangeability and linearity can be established. Above and below the effective working range of a meter its K factor is liable to vary so greatly with flowrate that it is no longer practical to use the meter for accurate measurement.

3.2.2 Effect of viscosity

Meters of all types are affected to some degree by changes in the viscosity of the liquid being metered, although those of certain type and design are affected more seriously than others. When the viscosity of the liquid being metered changes it may be necessary for the meter to be re-proved. Whether it is necessary or not will depend upon:

- the amount by which the viscosity has changed;
- the extent to which the K factor of the meter concerned is affected by changes in viscosity;
- the accuracy required.

3.2.3 Effect of temperature

Temperature changes affect K factor in two ways. Thermal expansion in the meter causes dimensions and clearances to alter; and temperature changes cause the viscosity of the liquid to change, and thus produce the effect mentioned in 3.2.2. The thermal expansion effect is often negligible in turbine meters, except where large temperature changes occur. With displacement meters the thermal expansion effect is more significant because dissimilar metals are frequently used in the measuring chamber so clearances are changed.

3.2.4 Effect of pressure

Pressure affects K factor both by producing dimensional changes in the meter and by causing viscosity changes in the liquid. The effect of pressure on viscosity however, is too small to be significant in most metering applications. The dimensional effect is usually small in some designs of meters for operation at high pressures, but can be significant in some meters. Pressure changes will not often have enough effect on K factor to justify re-proving.

3.2.5 Effect of wear, damage and deposits

As a meter wears, its K factor will gradually change and so a meter used for custody transfer purposes should be re-proved at regular intervals to take account of this, even if re-proving because of changes in viscosity and temperature is not necessary. Deposits of wax and dirt can cause similar effects.

Accidental damage to a meter is likely to alter its K factor considerably. If a meter is stripped for repairs it should be proved after it has been reassembled.

3.2.6 Frequency of proving

The necessary frequency of proving varies enormously, from several times a day to once a year, or longer. Very frequent proving is often justified where the total value of the metered liquid is high – for instance, where crude oil is being metered for fiscal purposes, or in major pipeline installations – and in these circumstances, it is usual for a large pipe prover to be 'dedicated' (permanently connected and stationary) to the metering system. The meters can easily be re-proved whenever the flowrate, temperature or viscosity change enough to warrant it, or whenever a new type of crude or product is being pumped. In some circumstances there may be a specified interval of time or a specified increment of throughput, after which the meter should be proved again.

In situations where not quite such a high accuracy is required, and where viscosity and temperature do not vary too widely, it is often sufficient for meters to be re-proved at specified intervals, such as every month or two when the metering system is new, extending to once in six or perhaps twelve months when the reliability of the meter system has been established. Master meters and portable proving tanks are still frequently used for this purpose, but the use of portable pipe provers is now quite common and this part of ISO 7278 therefore covers their operation as well as that of stationary pipe provers.

3.3 Correction factors

The volume of liquid pipe prover changes with both pressure and temperature; so does the specific volume of a liquid. To allow for these changes four correction factors are employed. These may either be used by the operator in manual calculations, or programmed into the data processor associated with the prover.

3.3.1 Corrections for change in volume of prover

For every pipe prover there is an important figure known as its base prover volume, V_b . This is determined through a calibration procedure which is carried out when the prover is built and subsequently at required intervals. It represents the volume within the calibrated section of the prover at some specified pressure and temperature, usually zero gauge pressure and 15 °C or 20 °C.

However, what the prover operator needs to know each time he carries out a proving run is the volume of the prover at the actual gauge pressure and temperature during that run. The gauge pressure will almost always be above zero, and this excess pressure will cause the prover to expand slightly. The temperature may be higher or lower than the reference temperature, and so its effect will be to cause the prover either to expand or contract.

To obtain the corrected volume of the prover at the appropriate pressure and temperature, the factors C_{ps} (or CPS) [correction for pressure on steel] and C_{ts} (or CTS) [correction for temperature on steel] are used. Detailed instructions for the use of these correction factors are given in ISO 4267-2.

3.3.2 Correction changes in specific volume of liquid

The corresponding factors to compensate for the effect of pressure and temperature upon the specific volume (the reciprocal of density) of the liquid are C_{pl} (or CPL) [correction for pressure on liquid] and C_{tl} or (CTL) [correction for temperature on liquid]. Their function is to convert a volume of oil, which has been measured at the observed pressure and temperature, to what is known as the "standard volume", which is the volume that the oil would occupy at an absolute pressure of one standard atmosphere (approximately 101 kPa) and some specified temperature such as 15 °C or 20 °C. Detailed instructions for the use of these correction factors are given in ISO 4267-2.

NOTE The correction factors referred to in 3.3.1 and 3.3.2 are functions of the type of liquid, its density, pressure, temperature and the standard pressure and temperature. A numerical value of one of these factors should never be used without checking that it is the right value for the conditions occurring at the time.

4 Meters and provers

4.1 Pulse-generating meters

Currently only two basic types of pulse-generating meter are commonly used for high-accuracy liquid metering in the petroleum industry.

One of these is the turbine meter. This consists essentially of a freely spinning propeller or “turbine” mounted on axial bearings inside a short length of pipe. When liquid flows along the pipe, the turbine rotates at a speed which is almost proportional to the flowrate and generates a series of electrical pulses. The pulses are fed into an electronic counter, from which the total volume passed through the meter is deduced. Refer to ISO 2715 for additional information.

The other meter type is the displacement meter, which was formerly known as the positive displacement or “PD” meter. Many types of these are in use and are discussed in ISO 2714. They may be thought of as devices resembling reciprocating or rotary piston pumps or perhaps gear or vane pumps which are driven by the liquid instead of by an external motor. The number of revolutions of the meter is essentially proportional to the total volume passing the meter, and this is normally displayed on a mechanical counter driven by a gear train. If an electrical pulse-generator is installed on the displacement meter, its output signal can be treated as if it were that of a turbine meter. In particular, such meters can be proved directly with a pipe prover, whereas displacement meters without an electrical output cannot.

4.2 Sources of error in operating meters

For a pulse-generating meter to give accurate results, the following three requirements shall be met:

- it shall be in good condition, both mechanically and electrically;
- conditions of the flowing fluid shall be suitable for metering and proving;
- the system shall be arranged so that the counter registers the same number of pulses as are generated by the meter – no more, no less.

The first of these is too obvious to need elaboration, but the other two involve some rather subtle difficulties which are explained in 4.2.1 and 4.2.2.

4.2.1 Flow conditions

The four main problems involving the flowing liquid are entrained solids, entrained air, cavitation and swirl.

Adequate filtration should be provided upstream of the meter.

Entrained air or gas affects every type of meter but the effects are usually more severe and less predictable with turbine meters than with displacement meters. Air or gas can get into the metered liquid in several ways. When a system is being filled with liquid, the air initially present should be vented. If the venting is not properly carried out, air pockets can be left in the line which will subsequently be swept through the meter. If a pump is drawing liquid from a tank where the surface level has been allowed to fall too low, it is likely that a “bath-tub” type of vortex will form and draw air into the pump. Where there is a danger of this occurring, a device known as a “gas separator”, “air separator” or “air eliminator” is often installed upstream of the meter to remove any air or gas which would otherwise enter the meter. Likewise, air or gas may enter a system under vacuum conditions.

Air or gas bubbles can also be formed right inside the liquid by a process known as “cavitation”. This occurs whenever there are local areas of low pressure, which can cause dissolved air or gas to be drawn out of solution in the liquid. This form of cavitation always produces a great number of very small bubbles. These minute bubbles cannot be removed by a separator and so there is no cure for cavitation — it simply has to be prevented from occurring. To achieve this, the pressure downstream of the meter shall not be less than the minimum specified by the manufacturer of the meter for the fluids being metered.

Another form of cavitation can affect volatile liquids such as crude oil, natural gas liquids, gasoline, liquefied petroleum gas, etc. If the pressure inside the meter falls momentarily to the vapour pressure of the liquid, then the liquid will boil. When this happens the liquid is said to “flash” within the meter. To prevent flashing, the line pressure immediately downstream of the meter shall be kept well above the vapour pressure of the liquid. Most meter manufacturers provide rules for the amount by which the back pressure at the meter shall exceed the vapour pressure. General rules for back pressure in turbine meters are also given in ISO 2715.

Immediately downstream of a partially opened valve, a bend or many types of pipe fitting, the liquid in the pipe can be subject to “swirl”. In other words, instead of following a straight path along the pipe the liquid may be moving in a corkscrew fashion. Swirl has little or no effect on the performance of displacement meters, but it seriously affects the performance of turbine meters. To suppress any swirl which can occur, it is usual for a device known as a flow straightener to be installed upstream of a turbine meter.

4.2.2 Electrical disturbances

A counter can miss some of the pulses generated by the meter, in which case it will read low. Or it can count some pulses that the meter has not generated, in which case it will read high.

If too few pulses are counted, this will usually be because the sensitivity control is improperly set, or because an electrical fault has developed. By adjusting the sensitivity control, or by rectifying any electrical fault that may exist, this trouble can usually be cured completely.

The counting of spurious pulses, however, is liable to be a more serious problem. It is dealt with at length in ISO 6551 and only a brief outline of the subject is given here.

Spurious pulses can originate in two ways:

- from surges in the electrical mains supplying the counter;
- from electromagnetic radiation.

The former is often referred to as “supply-borne noise”, and the latter as “airborne noise”. Electrical welding equipment and radio transmitters are common sources of airborne noise. Manufacturers are well aware of these problems, and normally build metering systems that are fairly well defended against spurious pulses.

The defences will usually include:

- filters on power mains designed to exclude supply-borne noise;
- preamplifiers at the meters, which will ensure a high signal-to-noise in the transmission line and thus make it less likely for airborne noise to be picked up;
- appropriately screened signal transmission cables earthed at only one point to avoid the occurrence of ground loops.

The route followed by signal transmission cable is of crucial importance. It should be kept as far away from AC power cables as possible, and if it has to cross a power cable it should do so at right angles. Spurious pulse counting is often caused by operators making unauthorized alterations to the wiring of their systems and inadvertently breaking these rules in the process.

Metering systems are sometimes fitted with a dual system of generating, transmitting and counting pulses to provide an indication that spurious pulses are not being counted. These are not infallible, but are a useful supplement to the operator’s own vigilance.

4.3 Pulse interpolators

Pulse interpolators are electronic devices that enable pulses from a meter to be counted to a fraction of a pulse, thus reducing the rounding-off error which occurs when pulses from a short proving run are counted to the nearest whole number. They perform best on meters with pulses emitted at regular intervals.

The purpose of using pulse interpolation devices is to allow for a discrimination of one part in ten thousand when you do not have 10 000 discrete pulses for one pass of the displacer. Details of various pulse interpolation systems are given in ISO 7278-3.

4.4 Conventional pipe provers

4.4.1 Principle of operation

See figure 1.

The basic principle on which the pipe prover operates is shown in figure 1. A piston or sphere known as a displacer is installed inside a specially prepared length of pipe. It is free to move along the pipe but it forms a sliding seal against the inner wall of the pipe so that it always travels at exactly the same speed as the liquid flowing through the pipe. When the prover is connected in series with a meter, the volume swept out by the displacer is equal to the volume passing through the meter.

In some conventional provers the displacer takes the form of a steel piston with duplicate elastomer seals, but in most conventional provers it is a slightly oversized elastomer sphere wedged in the pipe. To provide good sealing and acceptably low friction the pipe bore shall be smooth. In conventional provers this is generally achieved by coating or plating the bore.

At two or more points there are devices known as detectors fixed to the pipe wall. These provide an electrical signal at the precise moment the displacer reaches them. When the displacer reaches the first detector, its signal is used to direct the meter pulses to the prover counter. When the displacer reaches the second detector, its signal is used to stop the prover counter. The total number of pulses shown on this counter is therefore the number emitted by the meter while the displacer was travelling between the two detectors. The base volume (at standard pressure and temperature) of pipe swept out by the displacer as it travels between the two detectors is accurately known from a previous calibration of the prover. Thus it is possible to determine the number of pulses emitted by the meter while a known volume flows through it.

4.4.2 Types of conventional pipe prover

At the end of a run the displacer shall somehow be returned to its starting point, and there are two main ways of achieving this. In the *unidirectional prover* the displacer travels around a closed loop of pipe and so ends its run almost where it began; while in the *bidirectional prover* it is possible to reverse the flow through the prover and so make the displacer retrace its path. These are by far the most common types of prover, and it is with them that this part of ISO 7278 is concerned. They are described in detail in 4.4.2.1 and 4.4.2.2.

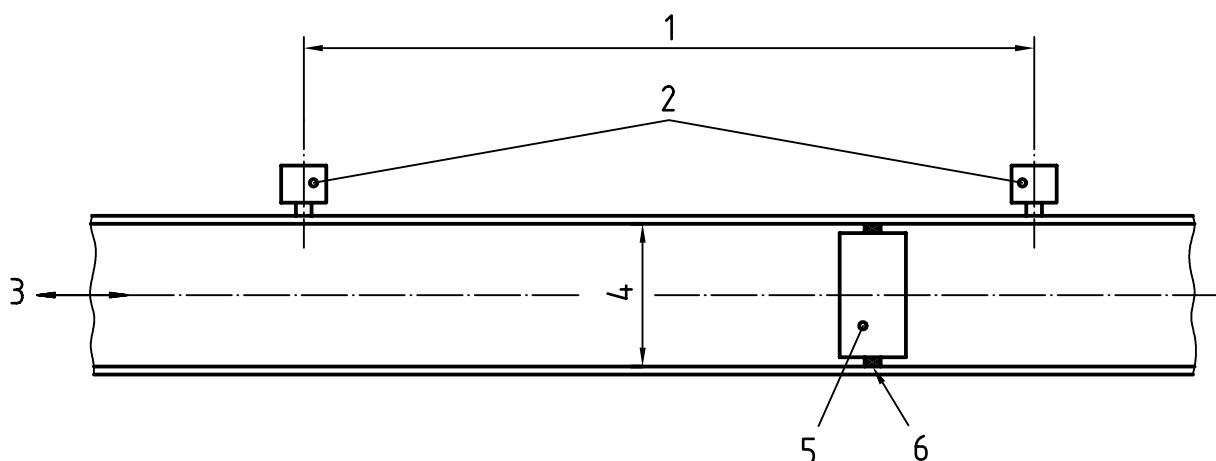

Key

- | | | | |
|---|---------------------------|---|--------------------|
| 1 | Calibrated length | 4 | Inner wall of pipe |
| 2 | Detectors | 5 | Displacer |
| 3 | Flow from or to the meter | 6 | Seal |

Figure 1 — Principle of operation of pipe prover

4.4.2.1 The unidirectional conventional prover

See figure 2.

The typical form of unidirectional prover is shown diagrammatically in figure 2. It uses an elastomer sphere as a displacer and incorporates a sphere-handling valve, which allows the sphere to drop through it when the valve is operated. After falling through the valve the sphere enters the flowing stream of liquid and is swept around the loop of the pipe. At the end of its circuit it drops into its rest position immediately above the sphere-handling valve, where it lies until the valve is actuated to launch the sphere on its next run.

Until the valve is fully seated it provides a path by which some of the flowing liquid can short-circuit the prover. It is essential that the sphere not enter the calibrated length of the prover until the bypass flow has ceased. A pre-run (or run-up) length of pipe is therefore provided between the point of entry of the sphere and the site of the first detector, to give the valve time to close and seal before the sphere reaches the detector. This type of prover shall never be used at more than its rated flowrate, or this pre-run length can prove inadequate. As an alternative, some provers are provided with some mechanical means of holding the sphere near the beginning of its travel until the valve is fully seated; by this means the pre-run length may be shortened considerably.

Less usual designs of the unidirectional prover use two or three spheres instead of using a sphere-handling valve.

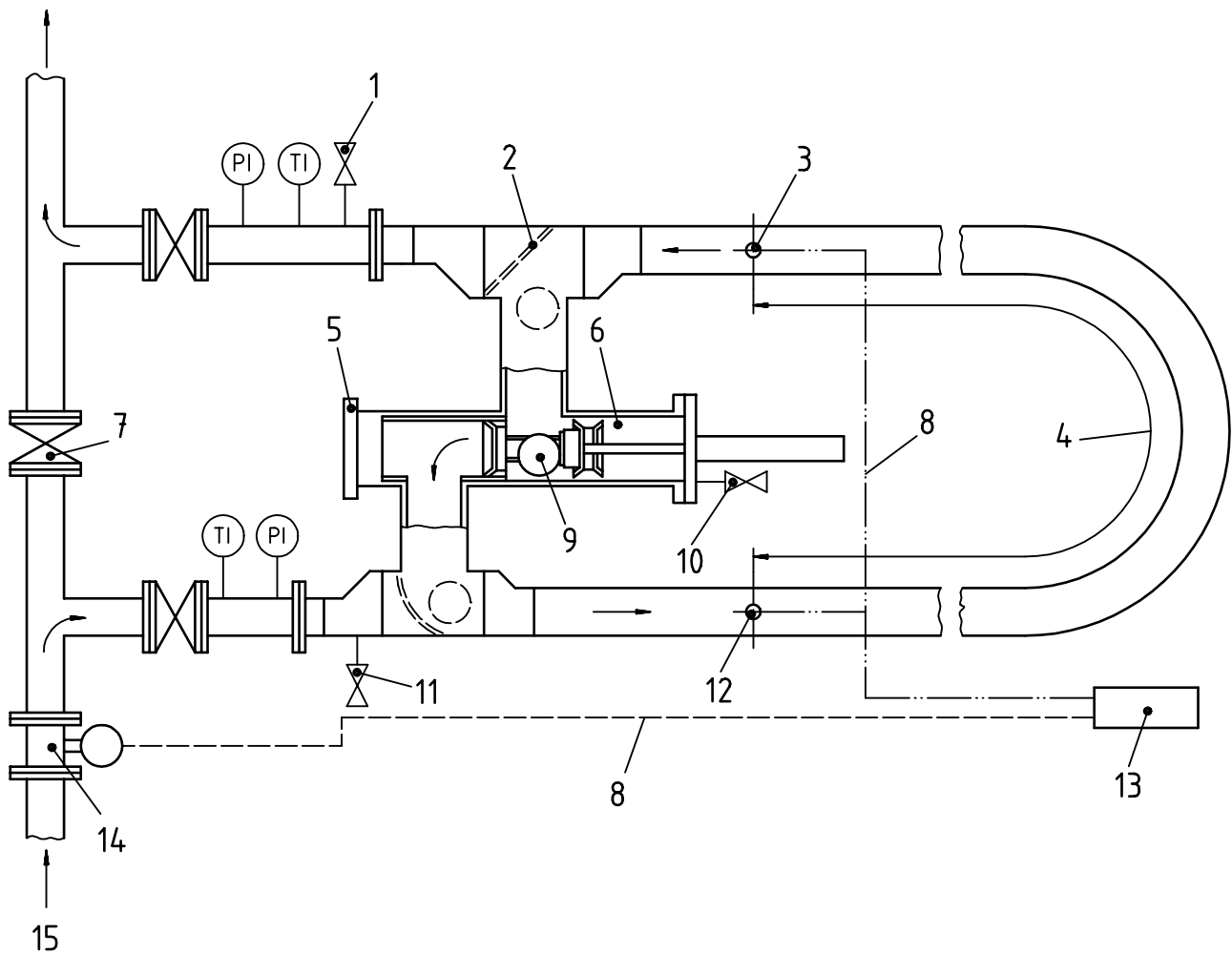

Key

- | | | | |
|---|------------------------------|----|-----------------------------|
| 1 | Block and bleed drain valve | 9 | Sphere |
| 2 | Sphere deflector assembly | 10 | Vent |
| 3 | Detector 2 | 11 | Block and bleed drain valve |
| 4 | Calibrated volume | 12 | Detector 1 |
| 5 | Hinged closure | 13 | Pulse counter |
| 6 | Sphere handling valve | 14 | Meter on test |
| 7 | Double block and bleed valve | 15 | Flow |
| 8 | Signal cable | | |

Figure 2 — Arrangement of a typical unidirectional prover

4.4.2.2 The bidirectional conventional prover

See figure 3.

Bidirectional provers can use either a sphere or a piston as a displacer. Spheres are more commonly used because they will travel around bends and so a bidirectional prover employing a sphere can be built in the form of a compact loop of pipework, as in the example shown diagrammatically in figure 3.

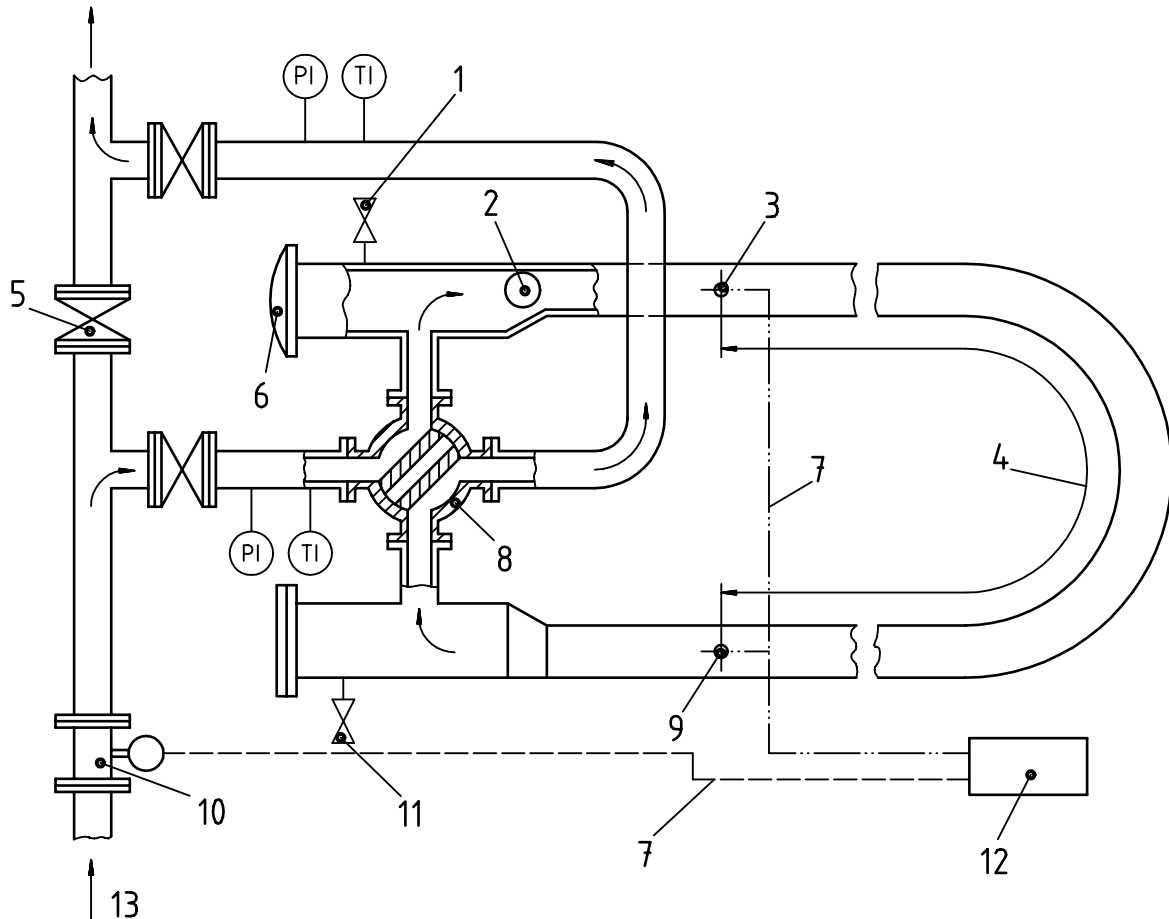

Key

- | | | | |
|---|------------------------------|----|-----------------------------|
| 1 | Block and bleed drain valve | 8 | Flow reversal valve |
| 2 | Sphere | 9 | Detector 2 |
| 3 | Detector 1 | 10 | Meter on test |
| 4 | Calibrated volume | 11 | Block and bleed drain valve |
| 5 | Double block and bleed valve | 12 | Pulse counter |
| 6 | Hinged closure | 13 | Flow |
| 7 | Signal cable | | |

Figure 3 — Arrangement of a conventional sphere type bidirectional prover

In this version, a flow reversal or four-way valve is employed to enable the flow through the prover to be reversed while the flow through the meter continues in one direction. (In some provers a set of four on/off valves linked together is sometimes used for flow reversal instead of a four-way valve.) The sphere in figure 3 is shown in the position that it occupies at the end of a proving run. The sphere will start to travel on its return run as soon as the turning of the valve begins to reverse the flow, but it will not reach its full speed until the movement of the valve is complete. The pre-run shall be long enough to ensure that the valve operation has finished before the sphere enters the calibrated length of the prover.

Some bidirectional provers are provided with a means of holding the sphere in its rest position while the four-way valve is turning. After a flow reversal is complete the sphere is released, so, that it suddenly enters the stream of

liquid which is already travelling at full velocity. Consequently, the sphere is forced to accelerate to full velocity very rapidly and so the pre-run lengths may be shorter in provers of this type.

Detectors are never quite symmetrical in their operation, and consequently the effective calibrated volume when the sphere travels between detector 1 and detector 2 ($V_{1,2}$) will not be quite the same as when it travels between detector 2 and detector 1 ($V_{2,1}$). It is therefore usual to take the sum of ($V_{1,2} + V_{2,1}$) as the calibrated base volume of the prover. This is termed the round-trip volume. Similarly, it is customary to arrange for the counter connected to a bidirectional prover to totalize the pulses collected in both directions ($n_{1,2} + n_{2,1}$) to give the round-trip pulse count.

4.4.3 Detectors

The most common type of detector employs a steel plunger with a rounded end, which projects through the wall of the pipe for approximately a centimetre. When the displacer makes contact, it forces the plunger outwards against the action of a spring until it is flush with the inside of the pipe wall. At some predetermined point in its short travel, the plunger operates a switch which may be either a mechanically operated microswitch or a magnetic switch. Other non-contacting type switches may be used on piston provers.

Although provers will operate satisfactorily with only one detector at each end, some provers are fitted with twin detectors at each end as a safeguard against the possible malfunctioning of one detector. Their use is described in annex A of ISO 7278-2:1988.

4.4.4 Displacers

The majority of displacers are thick-walled hollow spheres made of some oil-resistant elastomer such as neoprene or polyurethane. They are fitted with an inflation valve, or valves, and are intended to be inflated with water and/or glycol to a size where they maintain an effective seal in the prover bore without creating too much sliding friction. The manufacturer will usually specify the amount (typically between 2 % and 4 %) by which the sphere diameter needs to exceed the pipe bore. Sometimes, inflation pressure may be specified instead. Small provers may employ a sphere made of solid elastomer.

Spare spheres should not be stored in an inflated condition or lying on a flat surface. They should either be stored suspended in a net or sling, or on a protective sheet supported by a hollowed-out bed of sand, according to manufacturers' instructions.

If a piston is used as a displacer it may be fitted with seals of the cup type, especially in older provers. In many of the more modern provers, and particularly those designed for use with liquefied gases, the pistons are fitted with more elaborate seals.

4.4.5 Valves

It is essential that the sphere-handling valve in a unidirectional prover, the four-way valve or a four valve system in a bidirectional prover, and any valve in a line bypassing a prover, should seal completely when closed. This is because any leakage through them will bypass the prover and thus cause the prover to understate the volume flowing.

Such valves are therefore always of the "double-block-and-bleed" type. That is to say, they are double seated, and the space between the two seats is connected to a small bleed valve. By opening this bleed valve the operator can make a positive check that the main valve is not leaking because any leakage across either of the valve seats will reveal itself through the bleed. In some double-block-and-bleed systems, any leakage is allowed to pass freely through the bleed to a place where it can be seen flowing; in others, the bleed is connected to a pressure gauge so that rising or falling pressure is the indication of leakage.

4.5 Small volume pipe provers

Several new designs of pipe provers have been introduced within the last few years, and are gradually coming into widespread use. They are generally referred to as "compact pipe provers" or "small volume pipe provers", because they are much smaller than conventional pipe provers designed for the same flowrate.

4.5.1 Principle of operation

Small volume pipe provers employ the same basic principle as conventional pipe provers, as described in 4.4.1. Their greatly reduced size is made possible by the use of two recent developments, as follows.

- a) The manufacture of precision-bore cylinders with well-fitting pistons using electronic detectors that may be either optical, magnetic, ultrasonic, inductive or capacitive. The best of these have a precision of more than 20 times that of the electro-mechanical detectors used in conventional provers, and thus they make it possible for the distance between detectors to be reduced to approximately one metre.
- b) Pulse interpolation, which was described in 4.3, enables pulse counts to be made to quite a small fraction of a pulse – typically, to two decimal places; but it does not follow that the interpolated pulse count will be *accurate* to two decimal places. The accuracy obtainable depends upon the method of interpolation used, and upon the regularity of spacing of the meter pulses. In a well-designed turbine meter the interval between successive pulses generally does not vary by more than approximately $\pm 2\%$ from the mean interval, but in some displacement meters the variation can be up to $\pm 20\%$, or even more. This makes it difficult to prove some displacement meters with small volume provers. The use of pulse interpolation enables the base volume of small volume provers to be reduced to approximately one-twentieth of the base volume of conventional pipe provers with the same flowrate capacity.

Small volume provers are made with very short acceleration (pre-run) and deceleration lengths at the beginning and end of the piston travel. They achieve this either by using very quick-acting valves, or by mechanically restraining the piston from moving until the prover valve has completed its operation and then launching the piston suddenly.

There are two types of small volume pipe provers, unidirectional and bidirectional.

4.5.2 Unidirectional small volume pipe provers

See figures 4 and 5.

It is important to appreciate that the unidirectional small volume prover is not unidirectional in the same sense as the unidirectional conventional prover, described in 4.4.3. The conventional prover utilizes a sphere in an endless loop of pipe, and the sphere arrives back at its starting point when it has completed a run. The piston in a unidirectional small volume pipe prover cannot negotiate pipe bends, and so can return to its starting point only by retracing its path. It is unidirectional in that flow passes through the prover cylinder in only one direction so that proving can only take place with the piston travelling in that one direction.

To return the piston for another run it is necessary to open a bypass valve and force the piston in the reverse direction, usually with the aid of an externally-powered piston rod. As an alternative, it is possible to force the piston back by employing some means to create a reverse pressure differential across the piston.

One type of unidirectional small volume prover is shown in figure 4. An internal bypass valve system is incorporated, where a valve which allows oil to bypass the piston is incorporated within the piston itself; such an arrangement makes for extreme compactness of design. The piston detectors are mounted on the piston rod outside the cylinder, and are of the optical type and high precision and practically instantaneous response.

Other designs of unidirectional small volume provers utilize external bypass valves and are generally fitted with external detectors on the piston rod.

Unidirectional small volume provers are sometimes provided with an external pressure vessel surrounding an inner flow tube, as illustrated in the typical design shown in figure 5. This double cylinder arrangement prevents expansion of the calibrated volume under pressure and helps maintain the inner cylinder at constant temperature.

Many unidirectional small volume provers are provided with some means for regularly checking the leak-tightness of the seals in both the bypass valve and the piston, since any undetected leak in one of these seals could create an error in the measured volume.

The swept volume on the piston rod side of the piston will inevitably be less than the swept volume on the other side of the piston, for the same length of travel. Consequently a unidirectional small volume prover has two slightly different base volumes, and in calculations it is essential to use only the base volume of whichever end of the cylinder is directly connected to the meter on test.

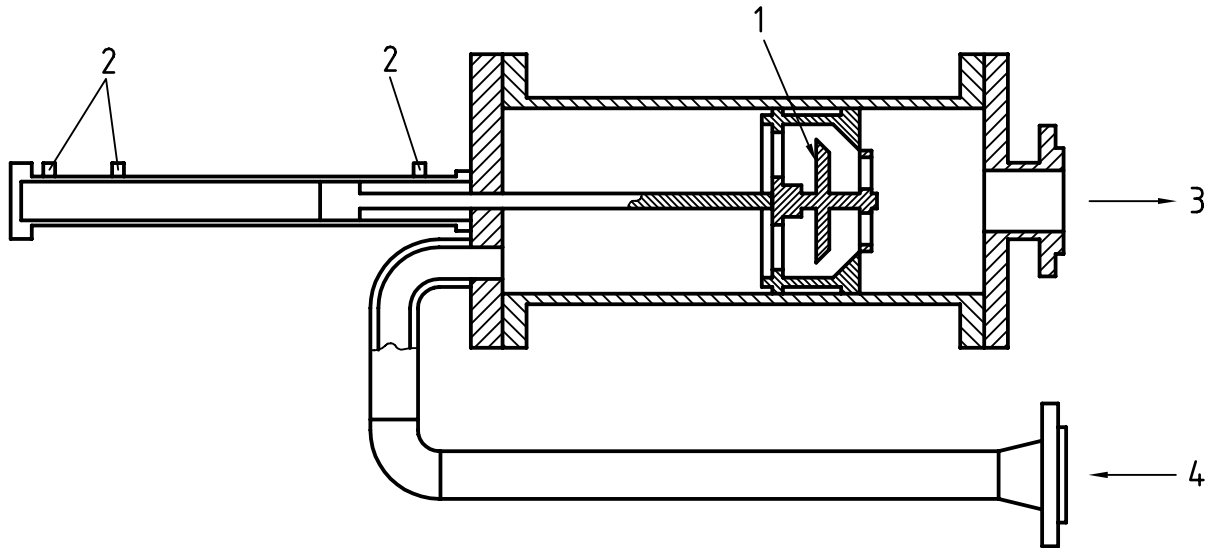

Key

- 1 Piston and poppet valve arrangement
- 2 Optical switches
- 3 Outlet
- 4 Inlet

Figure 4 — Example of a unidirectional small volume prover with internal valve

4.5.3 Bidirectional small volume provers

A bidirectional small volume prover is, in effect, a miniaturized version of a bidirectional conventional prover with a piston, as described in 4.4.4. There is no piston rod, and the piston detectors are installed inside the cylinder wall, where optical detectors cannot be used, and recourse has to be had to high-precision electrical or ultrasonic detectors.

Full bidirectional operation is achieved by using a four-way valve (or an assembly of simple valves) to reverse the mainline flow through the prover barrel. Some means of sudden launching after the valve has finished turning is always incorporated. The prover barrel may be either single-walled or double-walled, the latter having the advantages that were described in 4.5.2.

Double-block-and-bleed facilities are provided in the four-way valve to check its leak-tightness, just as in a conventional prover. In addition, there shall be some means for checking that the piston seal is leak tight.

4.6 Methods of installing pipe provers

4.6.1 Dedicated provers

A pipe prover may be permanently connected to a metering installation through a system of pipes and valves, so that any selected meter can be proved without any pipe connections having to be made. Such a prover is said to be “dedicated” to that metering system.

4.6.2 Mobile or portable provers

A portable prover is mounted upon a truck or a trailer so that it may be transported to a metering installation and temporarily connected with hoses or flexible pipework to pipe stubs which are permanently connected to the metering installation through valves.

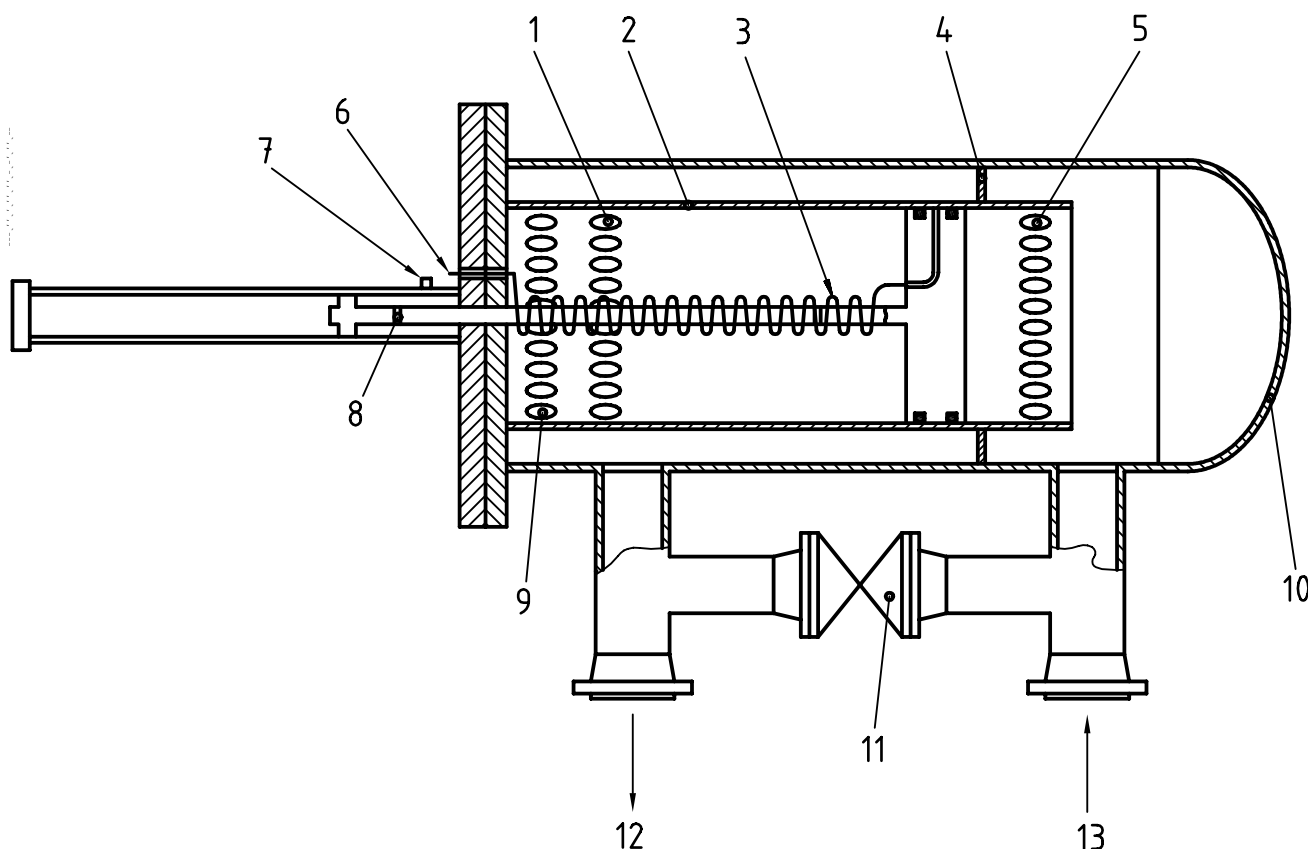
**Key**

- | | | | |
|---|---------------------|----|----------------|
| 1 | Outlet bypass ports | 8 | Gate marks (2) |
| 2 | Measuring cylinder | 9 | Brake ports |
| 3 | Flexible tube | 10 | Outer cylinder |
| 4 | Annulus seal | 11 | Bypass valve |
| 5 | Inlet bypass ports | 12 | Outlet |
| 6 | Piston seal check | 13 | Inlet |
| 7 | Optical sensor | | |

Figure 5 — Example of a unidirectional small volume prover with external valve

4.6.3 Central provers

A central prover is installed in proximity to a supply of one or more liquids, which can be admitted to the prover by opening valves. The meters to be proved with it are temporarily removed from their normal situations, brought to the central prover, and installed in the prover system while they are proved.

4.7 Sources of error in operating pipe provers

4.7.1 Entrained air and cavitation

Entrained air and cavitation will cause a prover to give misleading results, just as it does in a meter, as described in 4.2.1. It can be caused in the two ways described – inadequate venting of air when the system is first filled and by cavitation.

4.7.2 Temperature variations

Stable temperatures are essential if accurate results are to be obtained with a pipe prover. When oil begins to circulate through a prover which has been off line it takes some time for temperature equilibrium to be attained.

4.7.3 Flowrate variations

A meter's performance is dependent upon flowrate which shall be maintained as constant as possible during prover operations.

4.7.4 Detector maladjustment

The detectors fitted to conventional pipe provers are highly sensitive measuring devices. Repairing and adjusting them is a job for trained personnel. *Repairs to a detector can change the calibrated volume of the prover, thus making it necessary for the prover to be recalibrated.*

Errors caused by detector maladjustment are particularly serious in unidirectional provers. If a detector is wrongly adjusted, it is likely to cause a positive error when the sphere is travelling in one direction and a negative error when travelling the other way; in a bidirectional prover these two errors will partially cancel each other when the two runs are added together to give a round-trip result, but in a unidirectional prover the full effect of the error will always be felt.

4.7.5 Slippage past displacers

It is important that the displacer always make a complete seal with a pipe bore. If it does not, then some liquid slippage, or leakage, past the displacer will occur and a volume different than the calibrated volume will be swept out.

To ensure that this trouble does not arise, the displacer should be removed from the prover and examined at the intervals specified by the manufacturer or by the operating company. If the displacer is a piston, the seals should be inspected and replaced if there is any sign of mechanical damage or of softening by chemical action. In addition, the piston, while still in the prover, should be subjected to a leak test. Spheres should be inspected visually, but in addition their diameters should be checked with gauges.

When a prover is opened to check the displacer there is an opportunity to inspect the coating of the prover. Damaged coatings are not common but they are sometimes encountered and a badly damaged coating may need to be removed and/or replaced.

Before removing a displacer from a prover, note the warning in 5.3.8.

4.7.6 Valve leakage

As mentioned in 4.4.5, a prover valve which does not shut off the flow completely will cause serious errors. A double-block-and-bleed system should always be provided in these valves to enable their leak-tightness to be checked frequently. In some provers the double-block-and-bleed system is operated automatically, so that a check can be made during every proving run.

4.8 Prover calibration and recalibration

The initial base volume of the prover is determined prior to its first operation in accordance with the procedures discussed in ISO 7278-2. Thereafter, recalibration will be required at predetermined intervals as agreed upon by the authorities and the parties interested in the measurement. Recalibration is also required after any modification, repair or maintenance which can affect the base volume or the performance of the prover (e.g. detector maintenance, recoating of the prover intervals, etc.).

4.9 Meter installations

See figures 6 and 7.

Two typical metering installations are shown in figures 6 and 7. These are only given by way of example, since many variations in the design of installations can be encountered.

Installations designed to be used in conjunction with a portable prover will often be of the simple type shown in figure 6, with only one meter run. Installations containing a dedicated prover will frequently be of the multi-stream type shown in figure 7, where a number of meters in parallel can all be proved in turn against the one prover.

There are three important advantages with these types of installations when proving a meter.

- a) The meter remains in its normal position and does not have to be disturbed in any way.
- b) There is no interference with the day-to-day operation of the meter, which goes on totalizing the throughput while it is being proved.
- c) The meter is proved under its actual conditions of use – on the same liquid and at the same pressure, temperature and flowrate.

Installations like these will normally be provided with on-line data-processing facilities. These may take the form of a dedicated microprocessor, or of shared access to a larger computer, or both.

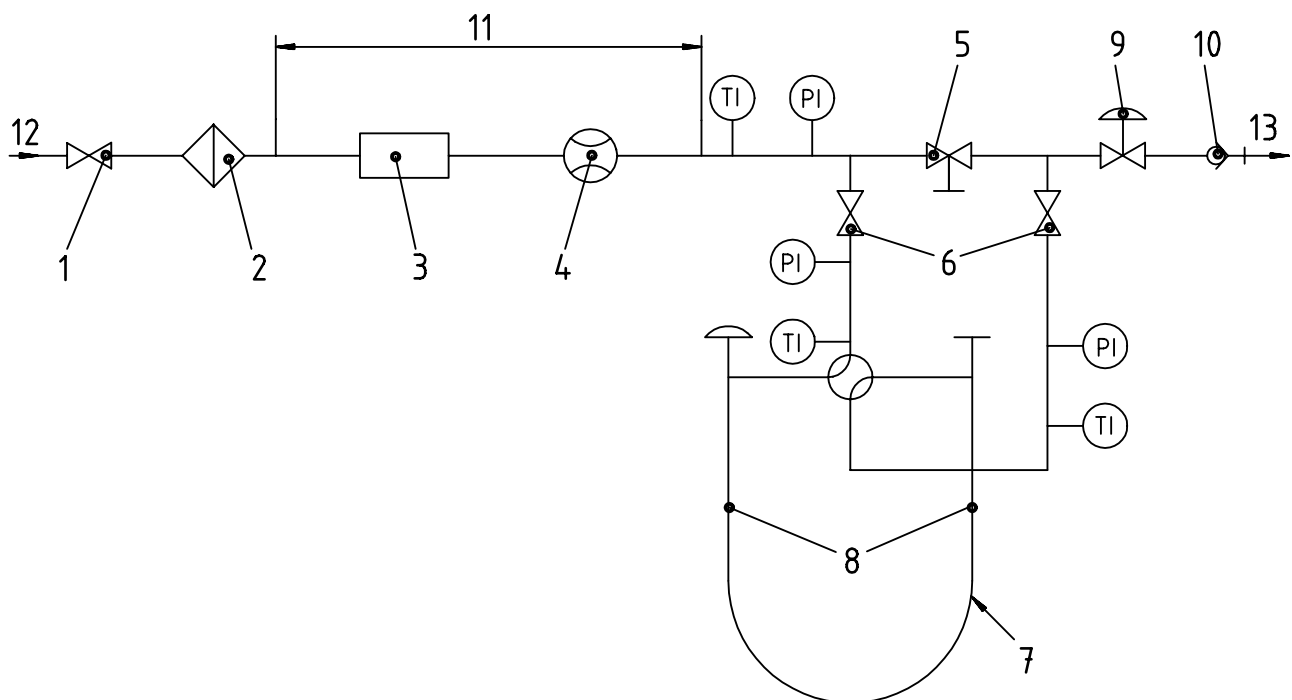

Key

- | | | | |
|---|--|----|----------------------------------|
| 1 | Upstream block valve | 8 | Detectors |
| 2 | Filter/strainer/air eliminator (as required) | 9 | Flow control valve (as required) |
| 3 | Flow conditioner | 10 | Non-return valve (as required) |
| 4 | Turbine flowmeter | 11 | Metering run |
| 5 | Main block valve (double block-and-bleed) | 12 | Flow in |
| 6 | Prover isolation valves | 13 | Flow out |
| 7 | Pipe prover | | |

Figure 6 — A simple turbine flowmeter installation with bidirectional prover

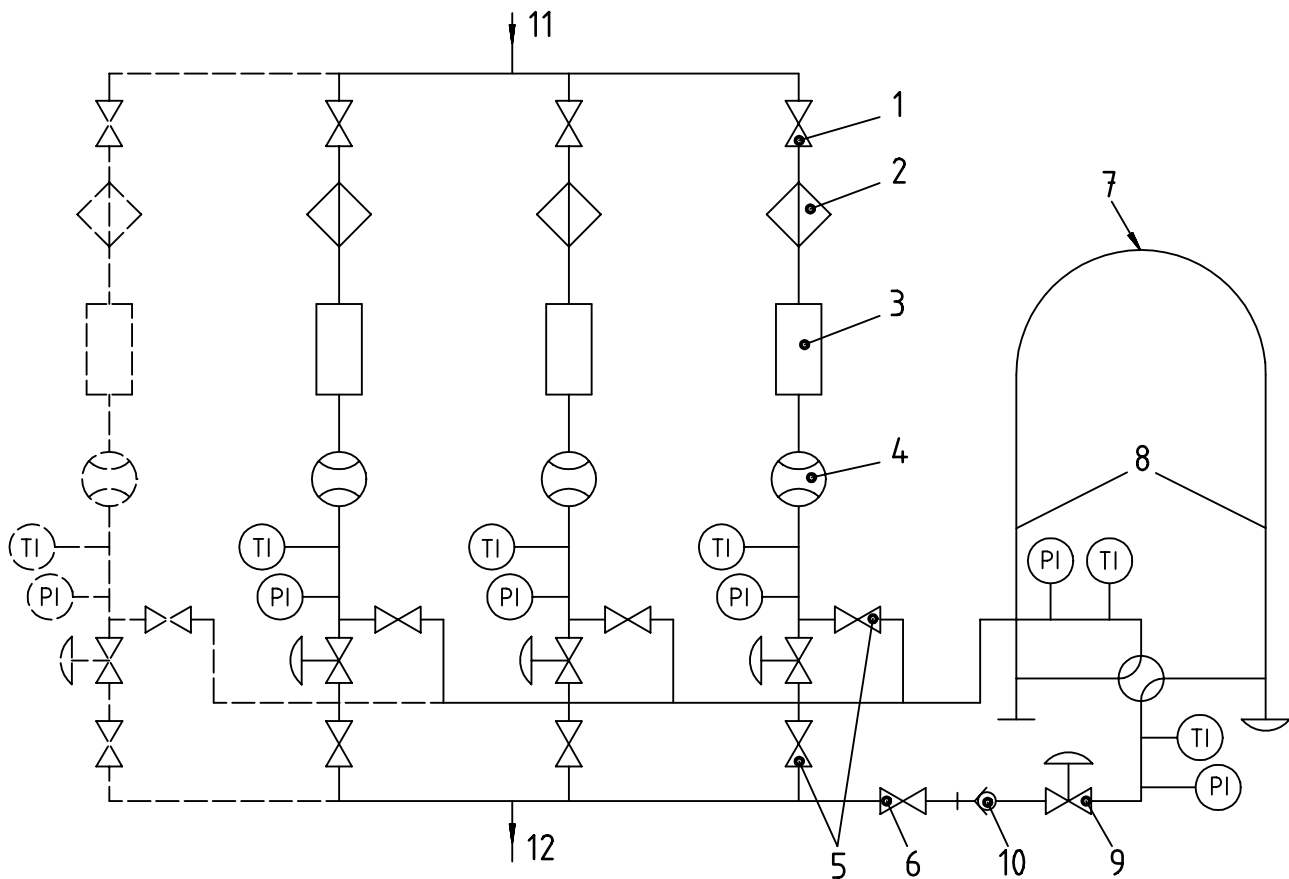

Key

- | | | | |
|---|---|----|-----------------------------------|
| 1 | Upstream block valves | 7 | Pipe prover |
| 2 | Filters/strainers/air eliminators (as required) | 8 | Detectors |
| 3 | Flow conditioners | 9 | Flow control valves (as required) |
| 4 | Turbine flowmeters | 10 | Non-return valve (as required) |
| 5 | Main block valves (double block-and-bleed) | 11 | Flow in |
| 6 | Prover isolation valves | 12 | Flow out |

Figure 7 — A typical multi-stream metering installation

5 Safety requirements

5.1 General

Safe methods of working are essential in every industry, and especially in the petroleum industry where great quantities of inflammable or combustible fluids are handled. The experience of many years has been embodied in various codes of safety regulations which affect the operation of pipe provers. It is a pipe prover operator's personal responsibility to make sure that he is familiar with all the regulations appropriate to the circumstances under which he is working, and to abide by these rules implicitly.

These rules fall into three categories. First, there are the safety regulations laid down by governments and which therefore have the force of law. Second there are codes of safe practice in the petroleum industry published by international and national standards organizations, which should also be closely followed.

Thirdly, each company in the petroleum industry normally has its own set of safety procedures drawn up with a particular piece of equipment in mind, and a pipe prover operator is required to make constant reference to his own company's safety manual until it becomes second nature to follow all its provisions.

In this part of ISO 7278 there is space to list only a few of the important features of good safety practice. The list given here does not set out to be exhaustive, and does not in any way remove the operator's responsibility to comply with the regulations mentioned above.

5.2 Permits

In many areas a pipe prover shall not be operated without a written permit or permits issued by the company owning the prover (and, if the site is owned by another company, by that company also). Work shall never start unless the operator is in possession of all the necessary permits.

Sometimes exceptional circumstances may arise which make it impossible to work without some relaxation of the normal safety regulations. If this happens, the matter shall be discussed with the local safety officer and his permission obtained in writing for the specific relaxation which is necessary before starting work. Permission of this kind shall not be given lightly, and shall only apply for the particular purpose and for the limited period stated on the permit. If this permit expires before the job is finished, contact the safety officer and obtain a new permit.

5.3 Mechanical safety

5.3.1 Pressure and temperature rating of pipe prover

The operator shall be familiar with the specified pressure and temperature ratings for the pipe prover and never subject it (or its connecting hoses, if it is a mobile prover) to conditions beyond its rating. In practice it is desirable to keep the pressure and temperature well below the rating, so as to allow a margin in case unexpected conditions occur. With a mobile prover it is essential to ensure that the rating is adequate for the application before taking the prover to the site.

5.3.2 Pressure testing of connecting hoses

The safety procedures followed by a company operating a mobile prover shall include a provision for testing the connecting hoses under pressure at a specified interval not to exceed two years and is more likely to be one year; it may be considerably less if circumstances call for this. Some companies call for on-site hose testing at the start of each visit by a proving contractor. Hoses should preferably be tested with water, never with a liquefied gas and if tested with a liquid hydrocarbon, the pressure shall be supplied by a hand pump, not from a high-pressure line. Records of the last successful hose test shall be available to be shown, by the operator, to the safety officer on request. Special precautions are needed when testing stainless steel hoses, which can be damaged by salt or alkaline water.

5.3.3 Connecting up portable provers

Before removing blind flanges from the connecting stubs in the metering installations, make absolutely certain that there is no pressure behind the flange. First, check that the isolating valves are fully closed. If there is an air vent between the valve and the blind flange, open it until the flange has been removed and then close it; otherwise, loosen all the nuts a few turns and then bleed out some oil before removing the nuts completely.

Before connecting a portable prover to a metering installation, always inspect the hoses. If there are any signs of excessive wear or damage, report this to the safety officer or supervisor and replace the hoses if required.

Hose connections between a portable prover and the metering system shall always be properly made up, using materials which are approved for the application concerned. In particular, the hoses shall be of suitable material, and so shall any jointing materials or gaskets which are used. Where there are flanged connections, the full number of bolts required for the joint shall be used and a sound gasket of the correct size shall be fitted.

5.3.4 Opening prover to supply pressure and filling prover

Dedicated and central provers are sometimes left open to the supply pressure with oil constantly circulating through the system. However, if such a prover has been closed off from the supply and drained, or when a portable prover has been newly coupled to a metering system, special care shall be taken when opening valves. To admit supply pressure to the prover in these circumstances, proceed as follows.

- a) Check that end closures and any other openable fittings are properly fastened, and that all vent and drain valves on the prover are closed.

- b) Cautiously admit supply pressure to the prover by cracking open first the metering system proving connection inlet valve, and then the prover inlet valve. When connecting a prover to a high vapour pressure liquid, the prover should first be pressurized with vapour before liquid is admitted. Admitting liquid to a prover at atmospheric pressure can freeze the valve and the prover seals.
- c) Open the air vents in the way described in detail in 5.3.5.
- d) Allow the prover to fill slowly while observing the system for leaks and while bleeding air. Wait until the system is completely filled and the connections have been shown to be leak-tight before fully opening the prover to supply pressure.
- e) At this point the outlet valves may safely be opened.
- f) After all the connecting valves are fully opened, the main block valve between the prover connection branches may then be closed safely.
- g) Run the prover a few times without taking readings and then use the vents again.
- h) Check all double-block-and-bleed valves.

5.3.5 Venting the prover

Caution shall be exercised when venting a prover that has just been opened to supply pressure, especially in systems where the mixture of air and oil issuing from the vent is not piped away to a reservoir. In these circumstances, it is necessary to use temporary receptacles to collect the vented oil. A pair of protective goggles shall be worn and the vent valves cracked open slowly. Liquefied gases shall not be vented to atmosphere, but into a flare-stack or other safe disposal system.

Vent valves that emit fluid directly into the atmosphere shall be installed so that the issuing stream is directed away from the operator. This shall be checked before opening the vent valve, and if found not to be the case, care shall be taken that the venting can be accomplished safely.

5.3.6 De-pressurizing and draining a portable prover

To disconnect a mobile prover from an installation, proceed as follows.

- a) Discuss the question of fluid disposal with the local operational management, and in particular check that the drainage system is adequate to cope with the quantity and surge that will follow the opening of the drain valve. High vapour pressure products will require special product disposal for liquid and vapour phases.
- b) Open the main block valve between the prover connections in the metering installation.
- c) Close the inlet and outlet valves in the connecting pipes.
- d) Close the inlet and outlet valves on the prover.
- e) Cautiously open the drain valves and then the vent valves.
- f) When the prover is empty, close the drain valves.
- g) Disconnect the hoses.
- h) Install blind flanges on the stub connections for hoses on the installation.

NOTE In many countries it is illegal to take a mobile prover on the public highways without first draining it.

5.3.7 Shutting off a dedicated or central prover

If a dedicated prover is to be closed off from the main metering system without being drained, or if a central prover is to be closed off from its supply system without being drained, it is essential to ensure that the prover is not shut in between closed valves. Before closing off the prover, always check that the pressure relief valve can discharge freely to relieve the excess pressure due to thermal expansion of the fluid in a confined space.

If a dedicated or central prover is to be drained for maintenance, proceed along the lines laid down in 5.3.6 for a mobile prover.

5.3.8 Removing a displacer from a prover

When it is necessary to remove a displacer, it shall be sent to the appropriate end-chamber if the prover is bidirectional or to the sphere-handling valve if the prover is unidirectional. Then drain the prover as instructed in 5.3.6 and remove the access cover. Provided that the displacer is where it should be it can then be removed easily, by hand if it is a small one or by a mechanical appliance if it is large.

Sometimes it will be found that on removing the access cover the sphere has not, in fact, arrived at the end of its travel but is further back in the prover barrel. If this happens only one procedure is permissible: replace the cover securely, refill the prover with liquid, and start again.

WARNING — Under no circumstances should you attempt to save time by forcing out the displacer with compressed air or gas, as this can have the disastrous consequence of shooting out of the displacer like a cannon ball and with enough force to severely injure personnel or damage facilities.

5.3.9 Special precautions when proving with LPG

For safety reasons it is best for LPG meters to be permanently connected to a dedicated prover. Where this is not done and the use of a mobile prover is necessary, the following special precautions are essential. 5.3.9.1 to 5.3.9.6 also apply when dedicated provers are being filled with LPG, or emptied of it.

5.3.9.1 Ordinary hoses shall not be used for making connections. Fabric reinforced hose designed for the service, flexible metallic hoses or jointed loading arms are required. When hoses are used, do not bend them into a smaller radius than the manufacturer permits and inspect frequently for corrosion and physical damage. When loading arms are used, carry out frequent inspections of the seals at the joints and maintain them in sound condition.

5.3.9.2 After connecting the prover, it may be necessary to purge out the air with low-pressure nitrogen so as to avoid the formation of an explosive mixture inside the prover during filling. Company operating requirements shall be observed.

5.3.9.3 If high-pressure nitrogen is available, increase the nitrogen pressure to nearly that of the LPG before starting to fill the prover; this will prevent rapid expansion and consequent icing when LPG is first admitted. Otherwise, take care to fill the prover sufficiently slowly to avoid icing.

5.3.9.4 While filling, connect the prover vent valves to a flare or other safe disposal system (see 5.3.5) until the prover is completely filled with LPG.

5.3.9.5 At the end of the operation, drain the prover into a safe disposal system, while admitting nitrogen (NOT air) through the vent valve(s). It is never permissible to empty a prover of LPG by venting it to atmosphere. Arrangements for emptying the prover shall be made in advance, before it is filled.

5.3.9.6 While a portable prover is connected to a system containing LPG, there shall always be someone in attendance who knows how to isolate the prover in case of emergency.

5.4 Electrical safety

5.4.1 Use of qualified staff

A prover operator shall not attempt to do any electrical work himself, but shall use a qualified electrician to do it for him. This applies to all electrical work, including the jobs referred to in 5.4.2 to 5.4.4.

5.4.2 Use of equipment of the correct type

Ordinary electrical and electronic equipment is capable of starting fires in areas where inflammable vapours can occur, and its use in such areas is therefore prohibited. Special electrical or electronic equipment, classified as "intrinsically safe", "explosion proof" and "flame proof" is provided for use in such areas.

SAFETY PRECAUTIONS — Hazardous areas are sub-divided into different zones, depending upon the degree of risk involved, and different types of electrical equipment are certified as suitable for use in the

various zones. Before introducing any new equipment to one of these zones, it is operator's responsibility to check that it is approved for use in that particular zone. Equipment which is not approved for the zone concerned shall never, under any circumstances, be used.

All cabling shall also be of an approved type.

5.4.3 Isolating the power supply

Ensure that the power supply is isolated and that the isolating switch is tagged whenever:

- a) temporary connections are being made to mobile equipment;
- b) any adjustment is being made to any electrical or electronic equipment (except for devices that have been specially designed to facilitate adjustment while running);
- c) flame-proof or explosion-proof enclosures are opened for any purpose.

5.4.4 Earthing and bonding

It is essential that all electrical and electronic equipment used in connection with a pipe prover be effectively earthed. All permanent earthing connections need to be tested periodically, at intervals which will normally be specified in the company's operating procedures, to assure that the electrical resistance to earth is below limits established by regulations or policy.

Bonding cables are provided to earth connect a mobile prover to a metering system while the prover is hydraulically connected to the metering system. Ensure that the bonding is properly completed before making any other electrical connections or pipe connections.

The continuity of bonding cables and connections shall be tested periodically as required in the company's operating procedures (probably at intervals of six months) and shall be inspected every time a bonding connection is made. Bonding terminals shall be kept clean.

Check the continuity of bonding in hoses at specified intervals.

5.5 Fire precautions

Portable fire extinguishers shall be located adjacent to a dedicated prover so that they are ready for immediate use. Before operating a dedicated prover, check that the fire extinguishers are in their correct places, that they are of the correct type and that the operator knows how to use them. Do not allow a fire extinguisher to be removed while the prover is in operation – unless, of course, there is a fire in the vicinity.

If a mobile prover is not supplied with its own fire extinguisher, its use shall not be permitted without first checking that appropriate extinguishers are available on site in the immediate vicinity.

Portable fire extinguishers shall be formally inspected at specified intervals, and the date of the last inspection shall be inscribed on the appliance. The date of the inspection of extinguishers shall be checked before operating a prover. If any fire appliance is out of date, report this immediately to the supervisor or safety officer so that the appliance can be changed.

WARNING — Many fires have been started because of careless disposal of oily waste and rags. These shall always be retained in a closed metal container provided for the purpose, until they can be permanently disposed of in a safe manner. Never leave oily rags lying about.

5.6 Miscellaneous safety precautions

5.6.1 Protective clothing

If protective clothing is provided, it shall be worn. Its purpose is to protect the operator from possible injury by harmful materials in the event of a mishap. When working with any materials, the wearing of protective clothing shall be compulsory.

In many circumstances, the use of a barrier cream may be necessary to protect hands against materials which can cause dermatitis or other skin complaints. If a barrier cream is provided, it shall be used.

5.6.2 Leaded fuels

Organic lead compounds are poisonous, and for this reason there are special regulations for the handling of all materials containing lead, including leaded fuels such as gasoline. Before operating a prover on a leaded fuel, the appropriate regulations shall be known and strictly observed.

5.6.3 Braking and jacking of portable provers

Brakes, stabilizing jacks, and the jockey-wheel gear on trailer mounted provers shall be tested at specified intervals, which should be every three months or more frequently. They shall also be inspected whenever a trailer-mounted prover is about to be unhitched from the towing vehicle. Truck mounted provers require similar precautions.

Brakes shall be applied, stabilizing jacks and any jockey-wheel gear set up and locked in position before attempting to couple the prover to the metering system. When preparing a portable prover for removal from a site, ensure that the stabilizing jacks and any jockey-wheel gear are fully retracted and locked in the retracted position.

5.7 Records

Every pipe prover shall be accompanied by its own log book unless another procedure for keeping safety and maintenance records covers the facilities of which the prover is a part. It is the duty of the prover operator to record all incidents affecting safety, operations and maintenance. All accidents shall be entered, whether they involve personal injury or not, and so shall any abnormal event which could have a bearing on the future operation of the equipment.

The record shall include the dates and results of the testing of all equipment which is required under safety regulations or operating procedures, including those tests mentioned above.

The operator shall submit this record book for inspection as procedures require and have it available at all times for inspection on demand.

6 Operating a pipe prover

6.1 Setting up a portable prover

Portable provers present special difficulties, because there is a great deal of preliminary work to be done before a prover is safely installed at a new location and ready for use. This section summarizes the preparatory work which should be done in a specific sequence.

6.1.1 Before setting out for the site, compare the specification of the metering station and the manufacturer's specification for the mobile prover to ensure that the prover is suitable for the job. In particular, check the flowrate, pressure, temperature and the nature of the liquid to be handled. If the prover was previously used on non-compatible liquid, it may need to be flushed out. Also, ensure that all parties involved in the proving have been advised, and that any necessary entry or safety permits have been obtained.

6.1.2 On arriving at the site, the operator should report to the site supervisor to arrange for assistance, identify the meters to be proved, identify connections, arrange for electrical power (if required), arrange for disposal of liquid – if not returned to pipeline, set up traffic barriers etc. Brake and jack the prover as specified in 5.6.3 – connect the earth connections specified in 5.4.4, and then connect the prover to the branch connections as described in 5.3.3 or 5.3.9.

6.1.3 Make other electrical connections.

6.1.4 If the displacer is not already inside the prover, insert it and securely fasten the end closure.

6.1.5 With ordinary liquids, admit line pressure, fill the prover and vent the air, as described in 5.3.4 and 5.3.5.

6.1.6 With liquefied gases, proceed as described in 5.3.9.

6.1.7 Some portable small volume provers are provided with a means to swivel the prover barrel into an upright position on arrival at the site. This is used for installations where the fluid can be contaminated with solid particles such as rust, scale, sand or other dirt. The particles are less likely to drop out and settle on the barrel walls where they can damage the displacer seals. The outlet of the prover should be at the bottom so that the contaminants are swept out by the fluid.

6.2 Warming up provers

Provers shall be brought to a condition of thermal equilibrium before an actual proving run may be started. This operation is generally termed “warming up”, even though it can sometimes involve cooling down the prover rather than increasing the temperature. It is achieved by allowing the liquid to flow through the prover until the prover barrel temperature equals the liquid temperature as closely as practical. Carry out a number of dummy runs with the prover in quick succession – that is to say, sending the displacer from end to end of the prover a number of times without taking any readings. During these dummy runs the opportunity should be taken to vent any remaining air or vapour, and to check that the detector switches and the prover counter are all functioning correctly. If there is time to spare during warming up, this can be utilized by checking the double-block-and-bleed valves.

During the warming up period, watch the temperatures at both the meter and the prover. If the meter and the prover are fairly close together, and if the temperature of the liquid is not too far removed from that of the ambient air, stable conditions should eventually be reached in which the temperatures at the meter and the prover are practically the same. In all circumstances, continue the warming up until the temperature difference reaches a constant value, and then carry out the proving without any delay so as to ensure that stable temperature conditions exist throughout the proving operation.

6.3 Periodical checks of factors affecting accuracy

To ensure that a high standard of accuracy is maintained, the following checks should be made periodically at the intervals specified in the company's procedures.

6.3.1 If the displacer is a sphere, its diameter shall be checked against the gauges, and the surface of the sphere inspected for damage. If the displacer is a piston, the seals shall be inspected and a leak test made, as described in 4.7.5.

6.3.2 All double-block-and-bleed valves shall be frequently checked for leakage.

6.3.3 Air vents shall be carefully cracked open to assure that further air has not been trapped in the prover since it was first filled.

6.4 The actual proving operation

6.4.1 Check that stable conditions of pressure, temperature and flowrate exist, and then without delay launch the displacer for the first proving run.

6.4.2 In the case of a unidirectional prover, record the reading of the prover counter at the end of this first run, together with the flowrate and the liquid temperatures and pressures at both the meter and the prover. If the installation is provided with thermometers at both the inlet and the outlet of the prover, note the readings of both and record the average temperature.

6.4.3 In the case of a bidirectional prover, as soon as the first run has been completed, initiate the return run so as to complete the round trip. (Many provers are programmed to initiate the return run automatically). After this, record the results as in 6.4.2.

6.4.4 Repeat the whole operation at least five times in quick succession to obtain a minimum of five complete sets of results. (This number may vary by agreement.)

6.4.5 Assess the repeatability of the set of results as specified in 6.5, and if necessary carry out additional runs in an attempt to obtain good repeatability. If repeatability is not obtained fairly quickly, stop work and look for the cause of the trouble, in accordance with 6.5 and 6.6.

6.4.6 In some installations where it is necessary to operate over a range of conditions such as varied products or flowrates, it will be necessary to vary the product or flowrate and prove the meter at several different conditions. When this is so, carry out the complete procedure given in 6.4.1 to 6.4.5 at each desired condition.

6.4.7 Where a central prover is being used, prove the meter under the conditions in which it will subsequently be operated.

6.4.8 Where a small volume prover is being used, a run will generally consist of several passes of the displacer and these will generally be initiated automatically by the prover's control system.

6.5 Assessment of the results

Unstable conditions or malfunctioning of the meter or prover will usually lead to poor repeatability in the proving systems. This is why it is essential to look immediately at the results of a set of five or more proving runs made in quick succession under the same conditions. If these are in good agreement, this is a fair indication that the results are acceptable.

It is important to note that good repeatability does not prove that the results are correct. Something could have gone wrong which throws all the results out by the same amount, in which case the successive tests could merely be repeating an incorrect result. At least, good repeatability shows there is a fair chance that the equipment is functioning correctly and it is always true that bad repeatability is a positive warning that something is seriously wrong with the apparatus.

There are various ways of assessing whether the repeatability of a set of readings is acceptable. In pipe prover operations it is generally sufficient to use a very simple test, namely to see whether all the readings in the set are within a certain degree of closeness. The difference between the highest and the lowest result in the set is known as the "range", and the simplest test for good repeatability is that the range of five or more results should not exceed a certain percentage, such as 0,05 %. In some circumstances statutory authorities or government departments will set the limits for the range of a set of results.

If the range of a set of results is unacceptably great, it is necessary to carry out a further series of runs to obtain another set, in hopes that whatever caused the poor repeatability will have rectified itself. If the repeatability of the second set is well within the specified range, this set of results may be adopted. But if the repeatability remains unacceptable, it is necessary to stop proving and look for the cause of the trouble as discussed in 6.6.

Other tests for the correct functioning of the equipment over a long period of time are based upon the way in which the meter factor of a given meter is found to vary when it has been proved at intervals by the same prover, and on the way in which the linearity (see 3.2.1) of a meter varies over a period of time. This evaluation of performance, over a long period, is best assessed by keeping a control chart, that is to say, a graph of meter factor plotted against the dates of tests. A specimen control chart is shown in figure 8. For detailed information on control charts, see ISO 4124.

6.6 Fault finding

It is usually much easier to see that a fault has arisen than to identify the cause of the fault so that it can be eliminated. To help operators find faults more quickly, the experience of a number of prover operators has been embodied in the trouble-shooting guide which is given in table 1. Various possible causes both of poor repeatability in proving and poor meter linearity are listed, and the method of looking for each suspected cause of trouble is stated. Finally, table 1 gives the corrective action needed to rectify the fault once its cause has been ascertained.

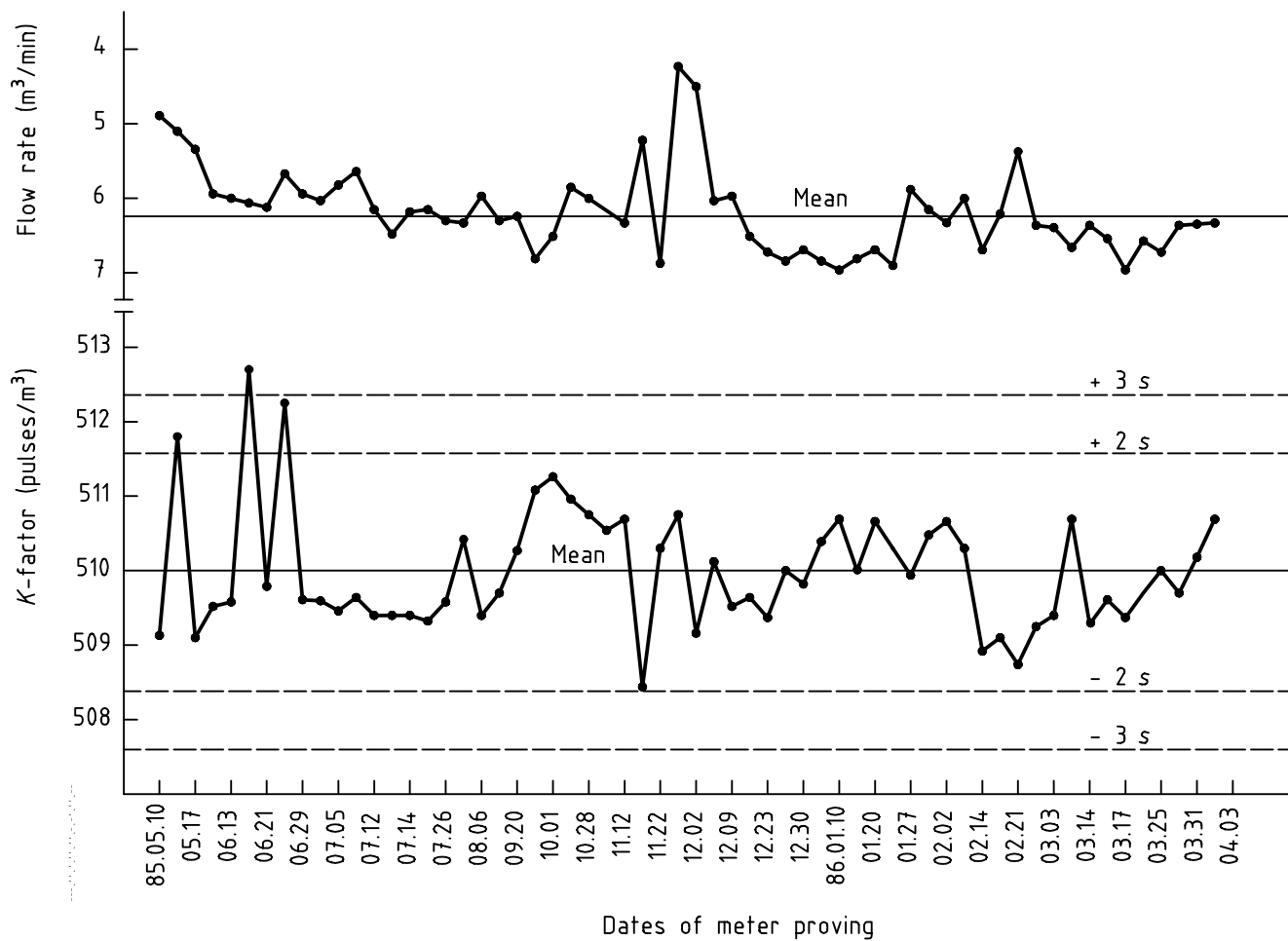

Figure 8 — Example of control chart

Table 1 — Trouble-shooting guide for pipe prover operators

Symptom	Possible cause	Test	Corrective action
Poor repeatability (range of 5 consecutive results > 0,05 % or > 0,10 % according to circumstances)	Prover		
	1. Entrapped air/gas	Open vent with sphere travelling, check for air/gas	Check for air in fluid to prover, vent prover high points and run prover several times to clean possible pockets
	2. Isolating valve leakage	Check double-block-and-bleed capability	a) Seat valve more firmly by increasing actuator or hand-wheel torque b) Replace seats
	3. Leakage in flow reversal valve or sphere-handling valve	Check double-block-and-bleed capability	a) Seat valve more firmly by increasing actuator or hand-wheel torque b) Replace seats
	4. Flow reversal valve or sphere-handling valve moves too slowly	Check double-block-and-bleed achieved before sphere reaches the first detector	Increase speed of operation of the valve or decrease flowrate through the prover
	5. Cavitation in flow reversal valve or sphere-handling valve	Measure pressure at the valve at maximum flowrate and see if it is in accordance with specification	Increase pressure by using back-pressure valve
	6. Detector(s)	Check detectors against external signal source or second pair of detectors if available	Inspect micro-switch(es) or other electrical parts of detector(s) for damage/corrosion and if necessary with complete matched detector(s)
	7. Sphere	Remove, inspect and check diameter and/or pressure	Inflate or deflate if necessary; replace if damaged
	8. Piston	Apply bleed test for leakage; remove piston and inspect seals	Replace seals if necessary
	Meter		
	9. Bearing wear	Dismantle and inspect	Replace or repair as required
	10. Random electrical interference	Erratic results	Trace and eliminate interference
11. Cavitation in meter	Measure pressure a few pipe diameters downstream of the meter at a maximum flowrate and see if in accordance with specification	Increase pressure by using back-pressure valve	
12. Pulse generator faulty	Check that pulse frequency is constant at constant flowrate	Replace or repair as required	

Table 1 — Trouble-shooting guide for pipe prover operators (*concluded*)

Poor linearity, i.e. changes in pulses per run over range of flowrates (say, > 0,05 % or > 1,0 %)	Prover		
	13. Flow-reversal valve or sphere-handling valve moves too slowly	Check double-block-and-bleed achieved before sphere reaches the first detector	Increase speed of operation of the valve or decrease flowrate through the prover
	14. Temperature variation	Measure temperatures accurately	Correct for temperature effects at both the meter <i>and</i> at the prover
	Meter		
	15. Bearing wear	Dismantle and inspect	Replace or repair as required
	16. Damaged rotor	Dismantle and inspect	Replace or repair as required

NOTE This trouble-shooting guide is based upon many years of experience with conventional pipe provers. Small volume provers have not been in widespread use for long, and they differ in construction from conventional provers. It remains to be seen whether all the advice in table 1 can be applied to small volume provers as confidently as to conventional provers.

Annex A (informative)

Bibliography

- [1] ISO 6551:1982, *Petroleum liquids and gases — Fidelity and security of dynamic measurement — Cabled transmission of electrical and/or electronic pulsed data.*
- [2] VIM, *International vocabulary of basic and general terms in metrology* — International Organization for Standardization, 1993.

ICS 01.040.87; 87.040.01

Price based on 27 pages
