

---

---

**Fire detection and alarm systems —  
Part 28:  
Fire protection control equipment**

*Systèmes de détection et d'alarme d'incendie —*

*Partie 28: Équipement de commande des systèmes de lutte contre  
l'incendie*





**COPYRIGHT PROTECTED DOCUMENT**

© ISO 2014

All rights reserved. Unless otherwise specified, no part of this publication may be reproduced or utilized otherwise in any form or by any means, electronic or mechanical, including photocopying, or posting on the internet or an intranet, without prior written permission. Permission can be requested from either ISO at the address below or ISO's member body in the country of the requester.

ISO copyright office  
Case postale 56 • CH-1211 Geneva 20  
Tel. + 41 22 749 01 11  
Fax + 41 22 749 09 47  
E-mail [copyright@iso.org](mailto:copyright@iso.org)  
Web [www.iso.org](http://www.iso.org)

Published in Switzerland

# Contents

Page

<b>Foreword</b> .....	<b>iv</b>
<b>Introduction</b> .....	<b>vi</b>
<b>1 Scope</b> .....	<b>1</b>
<b>2 Normative references</b> .....	<b>2</b>
<b>3 Terms, abbreviated terms, and definitions</b> .....	<b>2</b>
3.1 Definitions.....	2
3.2 Abbreviated terms.....	3
<b>4 Requirements</b> .....	<b>3</b>
4.1 General.....	3
4.2 Quiescent condition.....	3
4.3 Fire protection condition.....	4
4.4 Fault warning condition.....	6
4.5 Disabled condition — Optional function.....	8
4.6 Test condition — Optional function.....	9
4.7 Functional condition recorder — Optional function.....	9
4.8 Accessibility of indications and controls.....	10
4.9 Visual indications.....	10
4.10 Audible indications.....	11
4.11 Additional indications.....	12
4.12 Power supply.....	12
4.13 Mechanical.....	12
4.14 Integrity of transmission paths.....	12
4.15 Software.....	13
4.16 Data.....	14
<b>5 Tests</b> .....	<b>15</b>
5.1 General.....	15
5.2 Functional test.....	16
5.3 Environmental tests.....	17
5.4 Cold (operational).....	18
5.5 Damp heat, steady-state (operational).....	19
5.6 Impact (operational).....	20
5.7 Vibration, sinusoidal (operational).....	21
5.8 Electromagnetic compatibility (EMC), immunity tests (operational).....	22
5.9 Supply voltage variation (operational).....	23
5.10 Damp heat, steady-state (endurance).....	24
5.11 Vibration, sinusoidal (endurance).....	24
<b>6 Test report</b> .....	<b>25</b>
<b>7 Marking</b> .....	<b>25</b>
<b>Annex A (informative) Explanation of access levels</b> .....	<b>27</b>
<b>Annex B (informative) Design requirements for software-controlled fire protection control equipment</b> .....	<b>29</b>

## Foreword

ISO (the International Organization for Standardization) is a worldwide federation of national standards bodies (ISO member bodies). The work of preparing International Standards is normally carried out through ISO technical committees. Each member body interested in a subject for which a technical committee has been established has the right to be represented on that committee. International organizations, governmental and non-governmental, in liaison with ISO, also take part in the work. ISO collaborates closely with the International Electrotechnical Commission (IEC) on all matters of electrotechnical standardization.

The procedures used to develop this document and those intended for its further maintenance are described in the ISO/IEC Directives, Part 1. In particular the different approval criteria needed for the different types of ISO documents should be noted. This document was drafted in accordance with the editorial rules of the ISO/IEC Directives, Part 2 (see [www.iso.org/directives](http://www.iso.org/directives)).

Attention is drawn to the possibility that some of the elements of this document may be the subject of patent rights. ISO shall not be held responsible for identifying any or all such patent rights. Details of any patent rights identified during the development of the document will be in the Introduction and/or on the ISO list of patent declarations received (see [www.iso.org/patents](http://www.iso.org/patents)).

Any trade name used in this document is information given for the convenience of users and does not constitute an endorsement.

For an explanation on the meaning of ISO specific terms and expressions related to conformity assessment, as well as information about ISO's adherence to the WTO principles in the Technical Barriers to Trade (TBT) see the following URL: Foreword - Supplementary information

The committee responsible for this document is ISO/TC 21, *Equipment for fire protection and fire fighting*, Subcommittee SC 3, *Fire detection and alarm systems*.

This second edition cancels and replaces the first edition (ISO 7240-28:2008), which has been technically revised.

ISO 7240 consists of the following parts, under the general title *Fire detection and alarm systems*:

- *Part 1: General and definitions*
- *Part 2: Control and indicating equipment*
- *Part 3: Audible alarm devices*
- *Part 4: Power supply equipment*
- *Part 5: Point-type heat detectors*
- *Part 6: Carbon monoxide fire detectors using electro-chemical cells*
- *Part 7: Point-type smoke detectors using scattered light, transmitted light or ionization*
- *Part 8: Carbon monoxide fire detectors using an electro-chemical cell in combination with a heat sensor*
- *Part 9: Test fires for fire detectors [Technical Specification]*
- *Part 10: Point-type flame detectors*
- *Part 11: Manual call points*
- *Part 12: Line type smoke detectors using a transmitted optical beam*
- *Part 13: Compatibility assessment of system components*

- *Part 14: Design, installation, commissioning and service of fire detection and fire alarm systems in and around buildings*
- *Part 15: Point type fire detectors using scattered light, transmitted light or ionization sensors in combination with a heat sensor*
- *Part 16: Sound system control and indicating equipment*
- *Part 17: Short-circuit isolators*
- *Part 18: Input/output devices*
- *Part 19: Design, installation, commissioning and service of sound systems for emergency purposes*
- *Part 20: Aspirating smoke detectors*
- *Part 21: Routing equipment*
- *Part 22: Smoke-detection equipment for ducts*
- *Part 23: Visual alarm devices*
- *Part 24: Sound-system loudspeakers*
- *Part 25: Components using radio transmission paths*
- *Part 27: Point-type fire detectors using a scattered-light, transmitted-light or ionization smoke sensor, an electrochemical-cell carbon-monoxide sensor and a heat sensor*
- *Part 28: Fire protection control equipment*

## Introduction

This part of the ISO 7240 has been prepared by ISO/TC 21, Subcommittee SC 3, the secretariat of which is held by SA and is based on ISO 7240-28:2008.

Fire protection control equipment (FPCE) (ISO 7240-1:2014, Figure 1, item G) receives signals from control and indicating equipment (ISO 7240-1:2014, Figure 1, item B) and sends initiating signals to automatic fire protection equipment (AFPE) (ISO 7240-1:2014, Figure 1, item H). The initiating signals are used to operate AFPE, such as pumps associated with fire suppression systems, control doors, dampers, fans, and other equipment.

This part of ISO 7240 describes the mandatory functions that it is required on all FPCE covered by this part of ISO 7240, and optional functions with their associated requirements. It is intended that the options be used for specific applications, as recommended in application guidelines. Each optional function is included as a separate entity, with its own set of associated requirements, in order to permit the FPCE covered by this part of ISO 7240, with different combinations of functions, to conform to the specified requirements. It is necessary that FPCE complying with this part of ISO 7240 fulfil the requirements of all of the mandatory functions, together with the requirements of those optional functions that are provided.

Other functions associated with the fire detection and alarm system can also be provided, even if not specified in this part of ISO 7240.

# Fire detection and alarm systems —

## Part 28: Fire protection control equipment

### 1 Scope

This part of ISO 7240 specifies requirements, methods of test, and performance criteria for fire protection control equipment (FPCE) (ISO 7240-1:2014, Figure 1, item G) connected to automatic fire protection equipment (AFPE) (ISO 7240-1:2014, Figure 1, item H) installed in buildings.

The FPCE receives signals from fire detection control and indicating equipment (ISO 7240-1:2014, Figure 1, item B), sends control signals to, and indicates the condition of, the AFPE (see [Figure 1](#)). The control signals are used to initiate automatic fire protection equipment, such as pumps associated with fire suppression systems, control doors, dampers, fans, and the like.

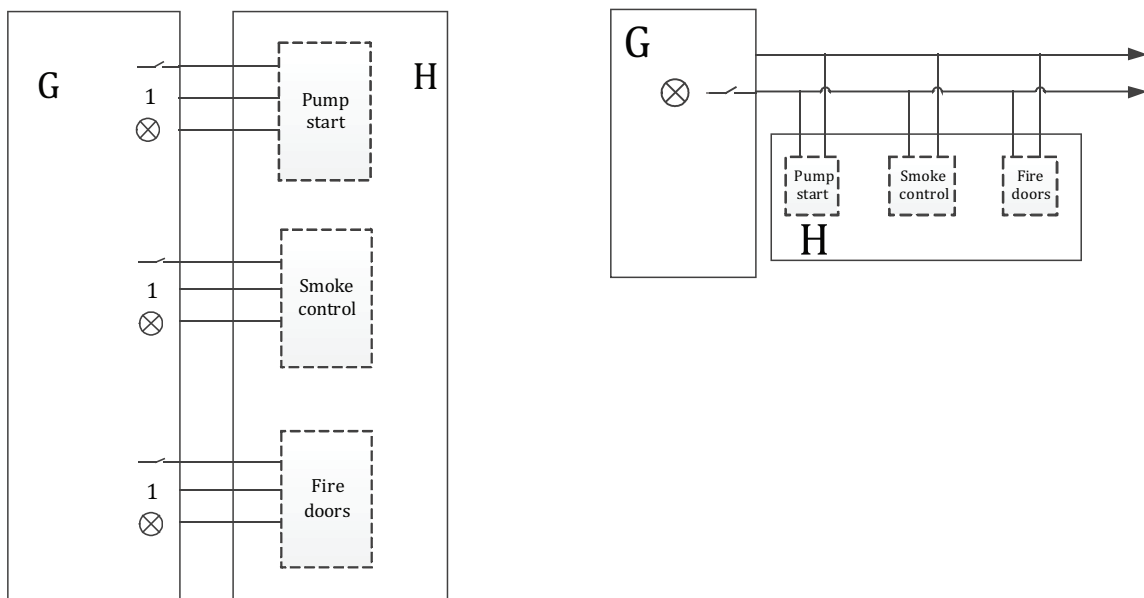

a) FPCE with discrete transmission paths

b) FPCE with serial transmission path

#### Key

G	fire protection control equipment
H	automatic fire protection equipment
1	automatic control
⊗	indicator
—	manual control

**Figure 1 — Typical fire protection control equipment configuration**

## 2 Normative references

The following documents, in whole or in part, are normatively referenced in this document and are indispensable for its application. For dated references, only the edition cited applies. For undated references, the latest edition of the referenced document (including any amendments) applies.

ISO 7240-1:2014, *Fire detection and alarm systems — Part 1: General and definitions*

ISO 7240-2, *Fire detection and alarm systems — Part 2: Control and indicating equipment*

ISO 7240-4, *Fire detection and alarm systems — Part 4: Power supply equipment*

ISO 7240-13, *Fire detection and alarm systems — Part 13: Compatibility assessment of system components*

IEC 60068-1, *Environmental testing — Part 1: General and guidance*

IEC 60068-2-1, *Environmental testing — Part 2-1: Tests — Tests A: Cold*

IEC 60068-2-6, *Environmental testing — Part 2-6: Tests — Test Fc: Vibration (sinusoidal)*

IEC 60068-2-47, *Environmental testing — Part 2-47: Tests — Mounting of specimens for vibration, impact and similar dynamic tests*

IEC 60068-2-75, *Environmental testing — Part 2-75: Tests — Test Eh: Hammer tests*

IEC 60068-2-78, *Environmental testing — Part 2-78: Tests — Test Cab: Damp heat, steady state*

IEC 60529, *Degrees of protection provided by enclosures (IP Code)*

IEC 60721-3-3, *Classification of environmental conditions — Part 3-3: Classification of groups of environmental parameters and their severities — Stationary use at weatherprotected locations*

EN 50130-4, *Alarm systems — Part 4: Electromagnetic compatibility — Product family standard: Immunity requirements for components of fire, intruder, hold up, CCTV, access control and social alarm systems*

## 3 Terms, abbreviated terms, and definitions

### 3.1 Definitions

For the purposes of this document, the terms and definitions given in ISO 7240-1 and the following apply.

#### 3.1.1

##### **functional condition**

condition of the FPCE characterized by its indication at the FPCE

Note 1 to entry: The functional conditions recognized in this part of ISO 7240 are the following:

- quiescent condition, specified in [4.2](#);
- fire protection condition, specified [4.3](#);
- fault warning condition, specified in [4.4](#);
- disabled condition, specified in [4.5](#);
- test condition, specified [4.6](#).



### 3.2 Abbreviated terms

AFPE	automatic fire protection equipment
FPCE	fire protection control equipment

## 4 Requirements

### 4.1 General

**4.1.1** The FPCE shall be capable of unambiguously controlling and indicating the following functional conditions, as described in [4.2](#) to [4.6](#):

- quiescent condition;
- fire protection condition;
- fault warning condition;
- disabled condition;
- test condition.

**4.1.2** The FPCE shall be capable of functioning simultaneously in any combination of the following functional conditions:

- fire protection condition;
- fault warning condition;
- disabled condition;
- test condition.

**4.1.3** If functions other than those specified in this part of ISO 7240 are provided, they shall not jeopardize compliance with any requirements of this part of ISO 7240.

**4.1.4** If an optional function is included in the FPCE, then all the corresponding requirements shall be met.

**4.1.5** Functions required in this part of ISO 7240 can be performed within fire detection control and indicating equipment complying with ISO 7240-2.

### 4.2 Quiescent condition

The FPCE shall be in the quiescent condition when the FPCE is powered, and no other functional condition is indicated. Any kind of system information can be displayed during the quiescent condition. However, no indications shall be given that can be confused with the

- fire protection condition,
- fault warning condition,
- disabled condition, or
- test condition.

## 4.3 Fire protection condition

### 4.3.1 Reception and processing of fire protection condition signals

**4.3.1.1** The FPCE shall receive fire alarm condition signals from fire detection control and indicating equipment (ISO 7240-1:2014, Figure 1, item B), and within 3 s, send signals as configured to initiate AFPE.

**4.3.1.2** Fire alarm condition signals shall be latched by the FPCE until reset.

**4.3.1.3** FPCE output signals shall be activated as part of the fire protection condition.

**4.3.1.4** FPCE output signals shall be configurable at access level 3. The configuration, at least, shall be dependent upon the fire alarm condition signals received from the fire detection control and indicating equipment, and shall allow for adaptations that can be required as part of the design of the fire detection and alarm system installed in or around the building.

**4.3.1.5** The mandatory indications and/or outputs shall not be falsified by multiple fire signals received from the same or different fire detection control and indicating equipment, resulting from the simultaneous operation of two sets of fire detection control and indicating equipment, and/or the operation of additional sets of fire detection control and indicating equipment.

### 4.3.2 Indication of the fire protection condition

**4.3.2.1** Indication of the fire protection condition is established when the following are present:

- a) a visible indication, by means of a separate light-emitting indicator (the general fire protection condition indicator);
- b) a visible indication of the FPCE output activation, as specified in [4.3.3](#), which can be omitted for FPCE and capable of sending signals to only one AFPE;
- c) an audible indication, as specified in [4.10](#).

**4.3.2.2** The time taken for processing signals within the FPCE shall not delay the indication of the fire protection condition at the FPCE by more than 3 s.

**4.3.2.3** The display of the fire protection condition shall take priority over the display of other conditions.

### 4.3.3 Automatic fire protection equipment

#### 4.3.3.1 Activation by fire protection control equipment

**4.3.3.1.1** Activation of the FPCE output shall be indicated by means of a separate light-emitting indicator, or a field of an alphanumeric display, or both, for each FPCE output.

**4.3.3.1.2** Where an alphanumeric display is used and separate light-emitting indicators for each FPCE output are not provided, a separate light-emitting indicator (the general output indicator) is also required.

**4.3.3.1.3** The output indicators shall be separate and distinct from the fire protection condition indicator.

**4.3.3.1.4** If the indications are on an alphanumeric display that, because of its limited capacity, cannot simultaneously indicate all activated equipment, at least the following shall apply:

- a) The total number of FPCE outputs activated shall be displayed until the FPCE has been reset.
- b) Activated FPCE outputs not currently indicated shall be capable of being displayed at access level 1 or 2. A single, manual action shall be required for each display of output information. When the last activated output is displayed, activation of the manual control shall cause the first output in the list to be re-displayed.
- c) The indication shall not be suppressed by indications of other functional conditions.

**4.3.3.1.5** The FPCE output indicator shall flash when the FPCE output is activated and go steady when the FPCE receives acknowledgement from the AFPE.

NOTE 1 The criteria used for the acknowledgement signal are dependent on the AFPE. For example, an acknowledgement signal for a smoke exhaust fan might not be sent from the exhaust fan control equipment until the fan has correctly started.

NOTE 2 Some activated equipment (e.g. valves for a gas cylinder) might not be capable of sending an acknowledgement signal. In this example, the output indicator remains flashing, indicating to the operator that the status of the AFPE remains unclear.

#### **4.3.3.2 Activation by means other than by the fire protection control equipment**

**4.3.3.2.1** Activation of the AFPE by means other than the FPCE (e.g. a suppression system directly activated by heat) shall be indicated by separate light-emitting indicators, or an alphanumeric display, or both, for each FPCE output. The indicators can be the same as those used in [4.3.3.1](#).

**4.3.3.2.2** When the AFPE is activated by means other than by the FPCE, the FPCE output visual indicator shall go steady and the audible indication, as specified in [4.10](#), shall activate.

NOTE If the AFPE is activated by means other than the FPCE, the activation is not considered as a fire protection condition; therefore, the reset function of [4.3.4.4](#) does not apply.

**4.3.3.2.3** The audible indication shall not be silenced automatically.

**4.3.3.2.4** If previously silenced, the audible indication shall re-sound for each new FPCE output activation.

#### **4.3.4 Manual controls**

##### **4.3.4.1 General**

**4.3.4.1.1** Manual controls shall be available at access level 2 to activate and deactivate the outputs of the FPCE.

**4.3.4.1.2** The time taken for processing manual control signals within the FPCE shall not delay the output activation at the FPCE by more than 3 s. Where more than one output is activated by a single manual control, the activation of each subsequent output can be delayed by not more than 3 s per output.

**4.3.4.1.3** When operated, a manual control shall suspend the programmed operation of the associated FPCE output. When the manual control is no longer in use, the programmed operation of the FPCE output shall resume from the point of suspension.

NOTE The resumption of programmed operation might need to include a re-examination of any active FPCE input signals.

#### 4.3.4.2 Indication of the activation of a manual control

4.3.4.2.1 Activation of the manual control shall be indicated by means of a separate light-emitting indicator, or an alphanumeric display, or both, for each FPCE output. The indicator shall be cancelled when the manual control is deactivated.

4.3.4.2.2 The activation of the manual control shall be indicated within 2 s of the completion of the manual operation.

#### 4.3.4.3 Other indications

If fault warning conditions, disabled conditions, or test conditions are indicated by means of separate light-emitting indicators, and such indications are suppressed in the manual control condition, it shall be possible to reveal these by means of a manual operation at access level 1 or access level 2.

#### 4.3.4.4 Reset

4.3.4.4.1 A manual control shall be provided to reset the FPCE from the fire protection condition at access level 2.

4.3.4.4.2 Indications of the fire protection condition shall be reset manually (see [4.3.4.4.1](#)) and can be reset automatically when the fire alarm condition is reset at the fire detection control and indicating equipment.

4.3.4.4.3 Following a reset, the indication of the correct functional conditions corresponding to any received signals shall either remain or be re-established within 20 s.

### 4.4 Fault warning condition

#### 4.4.1 Reception and processing of fault warning signals

4.4.1.1 The FPCE shall enter the fault warning condition when signals are received that, after necessary processing, are interpreted as fault.

4.4.1.2 The FPCE shall be capable of simultaneously recognizing all of the faults specified in [4.4.3.1](#) and [4.4.3.4](#), unless this is prevented by

- the presence of a fire protection condition from the same input, and/or
- the disablement of the corresponding input or output, and/or
- the testing of a corresponding input or output.

4.4.1.3 Faults specified in [4.4.3.1](#) and [4.4.3.4](#) shall be indicated without prior manual intervention, unless the FPCE is in the fire protection condition, in which case, the fault indications can be suppressed.

#### 4.4.2 Indication of the fault warning condition

4.4.2.1 The fault warning condition is established when all of the following are present:

- a) a visible indication by means of a separate light-emitting indicator (the general fault warning indicator);
- b) a visible indication for each fault, specified in [4.4.3.1](#);

c) an audible indication, as specified in [4.10](#).

**4.4.2.2** Faults shall be indicated within 100 s of the occurrence of the fault or as specified in [4.15.6](#).

#### **4.4.3 Indication of specific faults**

**4.4.3.1** The following faults shall be indicated by means of a separate light-emitting indicator, or an alphanumeric display, or both, and can be suppressed during the fire protection condition.

- a) an indication when the transmission of signals from fire detection control and indicating equipment is affected by
  - a short circuit in the input transmission path,
  - an interruption in the input transmission path;
- b) an indication when the transmission of signals to AFPE is affected by
  - a short circuit in the output transmission path,
  - an interruption in the output transmission path,
  - the removal of an output transmission path,
  - the disconnection of the AFPE from an output transmission path;
- c) an indication, at least common to any power-supply fault resulting from a short circuit or an interruption in a transmission path from a power supply (ISO 7240-1:2014, Figure 1, item L), where the power supply is contained in a cabinet different from that of the FPCE (indication can be satisfied by the absence of other indicators displayed in the quiescent condition);
- d) an indication at least common to any single earth fault that affects a mandatory function, and that is not otherwise indicated as a fault of a supervised function;
- e) an indication as a fault of the supervised function of the rupture of any fuse or the operation of any protective device that is capable of affecting a mandatory function in the fire protection condition;
- f) an indication of any short circuit or interruption, at least common to all transmission paths between parts of the FPCE contained in more than one mechanical cabinet, that is capable of affecting a mandatory function and that is not otherwise indicated as a fault of a supervised function;
- g) an indication of a software system fault in accordance with [4.15.4.1](#).

**4.4.3.2** If indication is by means of separate light-emitting indicators, the same light-emitting indicator can be used as that for the indication of the corresponding disable condition or test condition, although the indication shall be distinguishable.

**4.4.3.3** If the indication is on an alphanumeric display that cannot simultaneously indicate all the faults, the following shall apply:

- a) The presence of fault indications that have been suppressed shall be indicated.
- b) Suppressed fault indications shall be capable of being displayed by means of a manual operation at access level 1 or 2.

**4.4.3.4** Any short circuit or interruption in a transmission path between parts of the FPCE contained in more than one mechanical cabinet, where the fault does not affect a mandatory function, shall be indicated at least by means of the general fault warning indicator.

#### 4.4.4 Fault warning indications during the fire protection condition

4.4.4.1 The audible indication for the fault warning condition can be the same as that for the fire protection condition. If they are different, the fire protection condition indication shall have priority.

4.4.4.2 If faults are indicated by means of separate light-emitting indicators and such indications are suppressed in the fire protection condition, it shall be possible to reveal these by means of a manual operation at access level 1.

#### 4.4.5 Audible indication re-sound

If previously silenced, the audible indication shall re-sound for each newly recognized fault.

#### 4.4.6 Reset from the fault warning condition

Indications of faults shall be capable of being reset automatically when the faults are no longer recognized.

### 4.5 Disabled condition — Optional function

#### 4.5.1 General

4.5.1.1 The FPCE can have a provision to independently disable and re-enable each input and each output by means of manual operations at access level 2.

4.5.1.2 Disablement shall inhibit all corresponding mandatory indications and/or outputs, but shall not prevent other mandatory indications and/or outputs.

4.5.1.3 Disablement and re-enablement shall not be affected by a reset from the fire protection condition, manual control, the fault warning condition, or the test condition.

#### 4.5.2 Indication of the disabled condition

4.5.2.1 The disabled condition shall be indicated visibly by means of both of the following:

- a) a separate light-emitting indicator (the general disablement indicator);
- b) an indication for each disablement, as specified in [4.5.1.1](#).

4.5.2.2 Disablement shall be indicated within 2 s of the completion of the manual operation.

#### 4.5.3 Indications of specific disablement

4.5.3.1 If the indication of a specific disablement, as specified in [4.5.1.1](#), is by means of separate light-emitting indicators, the same light-emitting indicator can be used as that for the indication of the corresponding fault or test, although the indication shall be distinguishable.

4.5.3.2 If the indication is on an alphanumeric display that cannot simultaneously indicate all of the disablements, at least the following shall apply:

- a) The presence of disablement indications that have been suppressed shall be indicated.
- b) It shall be possible to reveal suppressed indications by means of a manual operation at access level 1 or 2.

## 4.6 Test condition — Optional function

### 4.6.1 General

**4.6.1.1** The FPCE can have a provision for testing the processing and indication of fire alarm signals from fire detection control and indicating equipment. This can inhibit the requirements during the fire protection condition that correspond to that input. In this case, at least the following shall apply:

- a) A test state shall be entered and cancelled only by a manual operation at access level 2 or 3.
- b) It shall be possible to test the operation of each function individually.
- c) Inputs in the test state shall not prevent the mandatory indications and outputs from inputs not in the test state.

**4.6.1.2** The test condition shall not be affected by a reset from the fire protection condition, the disabled condition, or the fault warning condition.

### 4.6.2 Indication of the test condition

**4.6.2.1** The test condition shall be indicated visibly, by means of the following:

- a) a visible indication (the general test indicator);
- b) an indication for each function in the test, as specified in [4.6.1.1](#).

**4.6.2.2** Tests shall be indicated within 2 s of the completion of the manual operation.

**4.6.2.3** The indications of each function in the test can be suppressed during the fire protection condition but the general test indicator shall not be suppressed.

### 4.6.3 Indication of specific tests

**4.6.3.1** If indication of a specific test, as specified in [4.6.1.1](#), is by means of separate light-emitting indicators, the same light-emitting indicator can be used as that for the indication of the corresponding fault or disable, although the indication shall be distinguishable.

**4.6.3.2** If the indication is on an alphanumeric display that cannot simultaneously indicate all of the tests, at least the following shall apply:

- a) The presence of test indications that have been suppressed shall be indicated.
- b) Suppressed indications shall be capable of being displayed by means of a manual operation at access level 1 or 2.

## 4.7 Functional condition recorder — Optional function

The FPCE can have a provision to record functional conditions. In this case, the following shall apply:

- a) The recorder shall record the date and time of at least the most recent 999 functional conditions in an electronic log.
- b) The date and time shall be maintained within 30 s of the real time relevant to the fire detection and alarm system.
- c) The log shall be maintained in non-volatile memory for at least 14 d with no power to the FPCE.

## 4.8 Accessibility of indications and controls

**4.8.1** Four access levels shall be provided on the FPCE, from access level 1 (most accessible) to access level 4 (least accessible) (see also [Annex A](#)). Allocation to an access level shall prevent access to an access level with a higher number, but allow access to an access level of a lower number. Manual controls and other functions shall be grouped on the appropriate access level, as specified in this part of ISO 7240.

**4.8.2** All mandatory indications shall be visible at access level 1 without prior manual intervention (e.g. the need to open a door).

**4.8.3** Manual controls at access level 1 shall be accessible without special procedures.

**4.8.4** Indications and manual controls that are mandatory at access level 1 shall also be accessible at access level 2.

**4.8.5** The entry to access level 2 shall be restricted by a special procedure.

**4.8.6** The entry to access level 3 shall be restricted by a special procedure, differing from that for access level 2.

**4.8.7** The entry to access level 4 shall be restricted by special means that are not part of the FPCE.

## 4.9 Visual indications

### 4.9.1 General

All mandatory indications shall be clearly identifiable, except where otherwise specified in this part of ISO 7240.

### 4.9.2 Indications by means of light emitting indicators

**4.9.2.1** Mandatory indications from light-emitting indicators shall be visible in an ambient light intensity up to 500 lx, at any angle up to 22,5° from a line through the indicator perpendicular to its mounting surface

- at 3 m distance for the general indications of functional condition,
- at 3 m distance for the indication of the supply of power, and
- at 0,8 m distance for other indications.

**4.9.2.2** For flashing indications, both the “on” period and the “off” period shall be greater than or equal to 0,25 s, and the frequencies of flash shall not be less than

- 1 Hz for fire protection condition indications, and
- 0,2 Hz for fault warning indications.

### 4.9.3 Indications on alphanumeric displays

**4.9.3.1** If an alphanumeric display consists of elements or segments, the failure of one of these shall not affect the interpretation of the displayed information.



**4.9.3.2** Where the FPCE is integrated with fire detection control and indicating equipment, a separate window shall be used for the FPCE. Alphanumeric displays used for mandatory indications shall have at least one clearly distinguishable window, consisting of at least two clearly identifiable fields.

**4.9.3.3** If not included in the displayed information, the purpose of each field shall be clearly labelled.

**4.9.3.4** Mandatory indications on an alphanumeric display shall be legible for the lesser of 1 h or the duration of the standby power source, following the display of a new indication of fire or fault, at 0,8 m distance, in ambient light intensities from 5 lx to 500 lx, at any angle from the normal to the plane of the display up to

- 22,5° when viewed from each side, and
- 15° when viewed from above and below.

**4.9.3.5** Following the lesser of 1 h or before the standby power source is exhausted where the primary power source is not available, the indications shall be legible at 100 lx to 500 lx, at the above distance and angles. It shall be possible to re-establish the legibility at 5 lx to 100 lx by means of a manual operation at access level 1.

#### **4.9.4 Colours of indications**

**4.9.4.1** The colours of the general and specific indications from light-emitting indicators shall be as follows:

- a) red for indications of fire protection conditions;
- b) yellow for indications of
  - fault warnings,
  - disablements, and
  - test state;
- c) green for the indication that the FPCE is supplied with power.

**4.9.4.2** The use of different colours is not necessary for indications on alphanumeric displays. However, if different colours are used for different indications, the colours used shall be as specified in [4.9.4.1](#).

#### **4.9.5 Testing of visual indicators**

All mandatory visual indicators shall be testable by a manual operation at access level 1 or level 2.

#### **4.10 Audible indications**

**4.10.1** Audible indicators shall be part of the FPCE. The same device can be used for both fire protection condition and fault warning condition indications.

**4.10.2** The audible indication shall be capable of being silenced by means of a separate manual control at access level 1 or 2.

**4.10.3** The minimum sound level at a distance of 1 m with any access door on the FPCE closed, shall be either

- 60 dB(A) for fire protection condition indications and 50 dB(A) for fault warning indications, or

— 85 dB(A) for fire protection condition indications and 70 dB(A) for fault warning indications.

NOTE The provision for two sets of audible indications allows for some FPCE being installed in areas that are normally occupied (such as a security room).

**4.10.4** The sound level shall be measured in anechoic conditions.

**4.10.5** Audible indicators shall be testable by a manual operation at access level 1 or access level 2. The control can be the same as that required in [4.9.5](#).

#### **4.11 Additional indications**

Where indications are used in addition to mandatory indications, these shall not result in contradiction or confusion.

#### **4.12 Power supply**

**4.12.1** The power supply for the FPCE shall comply with the requirements of ISO 7240-4. Where the FPCE is included within the fire detection control and indicating equipment cabinet, both sets of equipment can share the same power supply.

**4.12.2** A visible indication shall be given by means of a separate light-emitting indicator while the FPCE is supplied with power. Where the FPCE is integrated with the fire detection control and indicating equipment, a single power-supply indication can be used for both sets of equipment.

**4.12.3** Transitions between the main and the standby power sources shall not change any indications and/or the state of any outputs, except those relating to the power supplies.

**4.12.4** If the FPCE has provision for disconnecting or adjusting the main or the standby power source, this shall be possible only at access level 3.

#### **4.13 Mechanical**

**4.13.1** The cabinet of the FPCE shall be of robust construction, consistent with the method of installation recommended in the documentation. At access level 1, it shall meet at least classification IP30 of IEC 60529.

**4.13.2** The FPCE can be housed in more than one cabinet. In this case, the related indicators for the controls shall be grouped together in the same cabinet.

**4.13.3** All mandatory manual controls and light-emitting indicators shall be clearly labelled to indicate their purpose. The information shall be legible at 0,8 m distance in an ambient light intensity, from 100 lx to 500 lx.

**4.13.4** The terminations for transmission paths and the fuses shall be clearly labelled.

#### **4.14 Integrity of transmission paths**

**4.14.1** A fault in any transmission path between the FPCE and other components of the fire-detection system (as defined in ISO 7240-1) shall not affect the correct function of the FPCE or of any other required transmission path.

**4.14.2** If the manufacturer's documentation shows that an FPCE contained in more than one cabinet can be installed in separate locations (e.g. signal concentrator equipment), then the means shall be specified

and provided to ensure that a short circuit or an interruption in any transmission path between the cabinets does not affect more than one function for longer than 20 s following the occurrence of the fault.

**4.14.3** Where the FPCE is designed for use with a power supply (ISO 7240-1:2014, Figure 1, item L) contained in a separate cabinet remote from the FPCE, then an interface shall be provided for at least two transmission paths to the power supply, such that a short circuit or an interruption in one does not prevent the supply of power to the FPCE.

## **4.15 Software**

### **4.15.1 General**

The FPCE can contain elements that are controlled by software in order to fulfil requirements of this part of ISO 7240.

### **4.15.2 Software documentation**

**4.15.2.1** The manufacturer shall prepare documentation that gives an overview of the software design, which shall be submitted to the testing authority together with the FPCE. This documentation shall be in sufficient detail for the design to be inspected for compliance with this part of ISO 7240.

**4.15.2.2** The manufacturer shall prepare and maintain detailed design documentation. It is not necessary that this be submitted to the testing authority, but it shall be available for inspection in a manner that respects the manufacturer's rights of confidentiality.

### **4.15.3 Software design**

In order to ensure the reliability of the FPCE, measures shall be included in the program to prevent the occurrence of a deadlock in the system.

### **4.15.4 Program monitoring**

**4.15.4.1** The execution of the program shall be monitored (see also [Annex B](#)). The monitoring device shall signal a system fault if routines associated with the main functions of the program are not executed within a time limit of 100 s.

**4.15.4.2** The functioning of the monitoring device and the signalling of a fault warning shall not be prevented by a failure in the execution of the program of the monitored system.

### **4.15.5 The storage of programs and data**

**4.15.5.1** All executable code and data necessary to comply with this part of ISO 7240 shall be held in memory that is capable of continuous, unmaintained, reliable operation for a period of at least 10 years (see also [Annex B](#)).

**4.15.5.2** The program shall be held in non-volatile memory that can be written to only at access level 4. Each memory device shall be identifiable, such that its contents can be uniquely cross-referenced to the software documentation.

**4.15.5.3** For site specific data, the following requirements shall apply:

- a) The alteration of site-specific data shall be possible only at access level 3.
- b) The alteration of site-specific data shall not affect the structure of the program.

- c) If stored in volatile memory, the site-specific data shall be protected against power loss by a back-up energy source that can be separated from the memory only at access level 4, and that is capable of maintaining the memory contents for at least 2 weeks.
- d) If stored in read-write memory, there shall be a mechanism that prevents the memory from being written to during normal operation at access level 1 or 2, such that its contents are protected during a failure in program execution.
- e) The site-specific data shall be given a version reference, which shall be updated when each set of alterations is carried out.
- f) It shall be possible to identify the version reference of the site-specific data at access level 3.

#### 4.15.6 The monitoring of memory contents

The contents of the memories containing the program and the site-specific data shall be automatically checked at intervals not exceeding 1 h. The checking device shall signal a system fault if a corruption of the memory contents is detected.

### 4.16 Data

#### 4.16.1 General requirements and manufacturer's declarations

**4.16.1.1** The FPCE shall comply with the design requirements of [4.16](#), when relevant to the technology used.

**4.16.1.2** In order to assist the process of design inspection, the manufacturer shall declare the following in writing:

- a) that the design has been carried out in accordance with a quality management system that incorporates a set of rules for the design of all elements of the FPCE (e.g. ISO 9001);
- b) that the components of the FPCE have been selected for the intended purpose, and are expected to operate within their specification when the environmental conditions outside the cabinet of the FPCE comply with class 3k5 of IEC 60721-3-3.

**4.16.1.3** The manufacturer shall prepare installation and user documentation, which shall be submitted to the testing authority together with the FPCE. This shall be comprised of at least the following:

- a) general description of the equipment, including a list of the
  - optional functions with the requirements of this part of ISO 7240,
  - functions relating to other parts of ISO 7240, and
  - ancillary functions not required by this part of ISO 7240;
- b) technical specifications of the inputs and outputs of the FPCE, sufficient to permit an assessment of the mechanical, electrical, and software compatibility with other components of the system (e.g. as described in ISO 7240-1), in accordance with ISO 7240-13, including, where relevant,
  - the power requirements for recommended operation,
  - the maximum number of inputs and outputs,
  - the maximum and minimum electrical ratings for each input and output,
  - information on the communication parameters employed on each transmission path, and
  - recommended cable parameters for each transmission path,

- fuse ratings;
- c) installation information, including
  - the suitability for use in various environments,
  - if the FPCE is contained in more than one cabinet, how the requirements of [4.13.2](#) and [4.14.2](#) can be met,
  - if the FPCE is designed for use with a power supply contained in a separate cabinet, how the requirements [4.14.3](#) can be met,
  - mounting instructions, and
  - instructions for connecting the inputs and outputs;
- d) configuring and commissioning instructions;
- e) operating instructions;
- f) maintenance information.

**4.16.1.4** The manufacturer shall prepare design documentation, which shall be submitted to the testing authority together with the FPCE. This documentation shall include drawings, parts lists, block diagrams, circuit diagrams, and a functional description to such an extent that compliance with this part of ISO 7240 can be checked and that a general assessment of the mechanical and electrical design is made possible.

## 5 Tests

### 5.1 General

#### 5.1.1 Standard atmospheric conditions for testing

**5.1.1.1** Unless otherwise stated in a test procedure, conduct the testing after the test specimen has been allowed to stabilize in the standard atmospheric conditions for testing as specified in IEC 60068-1, as follows:

- a) temperature: 15 °C to 35 °C;
- b) relative humidity: 25 % to 75 %;
- c) air pressure: 86 kPa to 106 kPa.

**5.1.1.2** The temperature and humidity shall be substantially constant for each environmental test where the standard atmospheric conditions are applied.

#### 5.1.2 Specimen configuration

**5.1.2.1** The specimen configuration shall include at least one of each type of AFPE and transmission path. Where one of each type of AFPE is not practical, then the testing authority can simulate the AFPE and the signals that can be returned to the FPCE.

**5.1.2.2** The details of the AFPE shall be given in the test report (see [Clause 6](#)).

### **5.1.3 Mounting and orientation**

Unless otherwise stated in a test procedure, mount the specimen in its normal orientation by the normal means of mounting indicated by the manufacturer. The equipment shall be in the condition of access level 1, except where otherwise required for functional testing.

### **5.1.4 Electrical connection**

**5.1.4.1** If the test procedure requires the specimen to be in operating condition, it shall be connected to a power supply complying with the requirements in ISO 7240-4.

**5.1.4.2** Unless otherwise required, the power supply shall be in the nominal operating condition.

**5.1.4.3** All circuits and transmission paths shall be connected to cables and equipment or to dummy loads. At least one of each type of circuit shall be maximally loaded, all within the manufacturer's specification. Equipment other than the FPCE may be kept in the standard atmospheric condition during the tests.

### **5.1.5 Provision for tests**

**5.1.5.1** At least one FPCE shall be provided for testing compliance with this part of ISO 7240.

**5.1.5.2** The specimen or specimens submitted shall be representative of the manufacturer's normal production and shall include the claimed options.

## **5.2 Functional test**

### **5.2.1 Object of the test**

The objective of the test is to demonstrate the operation of the equipment before, during, and/or after the environmental conditioning.

### **5.2.2 Test schedule**

Draw up a test schedule to ensure that during the functional test, each type of input function and each type of output function is exercised.

#### **5.2.2.1 Fire protection condition**

**5.2.2.1.1** Initiate and reset the fire protection condition.

**5.2.2.1.2** Initiate and reset the manual controls.

**5.2.2.1.3** Check that the correct output to the AFPE is given and that the correct indication at the FPCE is given.

#### **5.2.2.2 Fault warning condition**

**5.2.2.2.1** Initiate and reset the fault warning condition.

**5.2.2.2.2** Check that the correct output to the AFPE is given and that the correct indication at the FPCE is given.

### 5.2.2.3 Disabled condition

5.2.2.3.1 Initiate and reset the disabled condition.

5.2.2.3.2 Check that the correct output to the AFPE is given and the correct indication at the FPCE is given.

### 5.2.2.4 Test condition

5.2.2.4.1 Initiate and reset the test condition.

5.2.2.4.2 Check that the correct output to the AFPE is given and that the correct indication at the FPCE is given.

### 5.2.2.5 Functional condition recorder

5.2.2.5.1 Initiate and reset the functional conditions on the FPCE.

5.2.2.5.2 Check that each functional condition and status is recorded in the log.

5.2.2.5.3 Disconnect the power from the FPCE for a period of not less than 1 h.

5.2.2.5.4 Check that the contents of the log have not been lost or corrupted.

NOTE This test can be performed in conjunction with the other tests in [5.2.2](#).

## 5.3 Environmental tests

### 5.3.1 General

One, two, or three specimens can be supplied for environmental testing. The required tests are shown in [Table 1](#).

**Table 1 — Environmental tests**

Test	Operational or endurance	Subclause reference
Cold	Operational	<a href="#">5.4</a>
Damp heat, steady-state	Operational	<a href="#">5.5</a>
Impact	Operational	<a href="#">5.6</a>
Vibration, sinusoidal	Operational	<a href="#">5.7</a>
Electromagnetic compatibility (EMC) immunity tests	Operational	<a href="#">5.8</a>
Supply voltage variation	Operational	<a href="#">5.9</a>
Damp heat, steady-state	Endurance	<a href="#">5.10</a>
Vibration, sinusoidal	Endurance	<a href="#">5.11</a>

### 5.3.2 Tests for one specimen

If a single specimen is supplied for environmental testing, subject the specimen to all the operational tests, which can be carried out in any order. After the operational tests, conduct the endurance tests on the same specimen in any order. Before and after each environmental test, conduct a functional test.

NOTE The functional test after one environmental test can be taken as the functional test before the next environmental test.

### 5.3.3 Tests for two specimens

If two specimens are supplied for environmental testing, then subject the first test specimen to all the operational tests, which can be carried out in any order, followed by one of the endurance tests. Subject the second specimen to the other endurance test. Before and after each environmental test, conduct a functional test.

NOTE For the first specimen, the functional test after one environmental test can be taken as the functional test before the next environmental test.

### 5.3.4 Tests for three specimens

If three specimens are supplied for environmental testing, then subject one test specimen to all the operational tests, which can be carried out in any order. Subject the second specimen to one of the endurance tests, and subject the third specimen to the other endurance test. Before and after each environmental test, conduct a functional test.

NOTE For the first specimen, the functional test after one environmental test can be taken as the functional test before the next environmental test.

### 5.3.5 Requirements

**5.3.5.1** During the tests of [5.4](#) to [5.9](#), the specimen shall not change status in each of the functional conditions as specified in the corresponding subclauses, except when such a change is required by the test procedure or when the change is a result of a functional test.

**5.3.5.2** However, in the tests of [5.8](#), [5.10](#), and [5.11](#), visible and audible indications of purely transitory nature occurring during the application of the conditioning are allowed.

**5.3.5.3** When subjected to the functional test, each specimen shall respond correctly (see [5.2](#)).

## 5.4 Cold (operational)

### 5.4.1 Objective of the test

The objective of the test is to demonstrate the ability of the equipment to function correctly at low ambient temperatures, appropriate to the anticipated service environment.

### 5.4.2 Test procedure

#### 5.4.2.1 General

Use the test procedures with gradual changes in temperature as specified in IEC 60068-2-1. Use test Ad for heat-dissipating specimens (as defined in IEC 60068-2-1) and use test Ab for non-heat-dissipating specimens.



#### 5.4.2.2 Initial examination

Before conditioning, subject the specimen to the functional test.

#### 5.4.2.3 State of the specimen during conditioning

5.4.2.3.1 Mount the specimen, as specified in [5.1.3](#), and connect it to suitable power-supply, monitoring, and loading equipment (see [5.1.4](#)).

5.4.2.3.2 The specimen shall be in the quiescent condition.

#### 5.4.2.4 Conditioning

Apply the following severity of conditioning:

- temperature:  $(0 \pm 3)$  °C, or other minimum rated temperature;
- duration: 16 h.

#### 5.4.2.5 Measurements during conditioning

Monitor the specimen during the conditioning period to detect any change in status. During the last hour of the conditioning period, subject the specimen to the functional test.

#### 5.4.2.6 Final measurements

After the recovery period, subject the specimen to the functional test and inspect it visually for mechanical damage both externally and internally.

### 5.5 Damp heat, steady-state (operational)

#### 5.5.1 Objective of the test

The objective of the test is to demonstrate the ability of the equipment to function correctly at high relative humidities (without condensation) which can occur for short periods in the service environment.

#### 5.5.2 Test procedure

##### 5.5.2.1 General

Use the test procedure specified in IEC 60068-2-78.

##### 5.5.2.2 Initial examination

Before conditioning, subject the specimen to the functional test.

##### 5.5.2.3 State of the specimen during conditioning

5.5.2.3.1 Mount the specimen, as specified in [5.1.3](#), and connect it to suitable power-supply, monitoring, and loading equipment (see [5.1.4](#)).

5.5.2.3.2 The specimen shall be in the quiescent condition.

#### 5.5.2.4 Conditioning

5.5.2.4.1 Apply the following severity of conditioning:

- temperature:  $(40 \pm 2)$  °C;
- relative humidity:  $(93^{+2}_{-3})$  %;
- duration: 4 d.

5.5.2.4.2 Precondition the specimen at the conditioning temperature  $(40 \pm 2)$  °C until temperature stability has been reached to prevent the formation of water droplets on the specimen.

#### 5.5.2.5 Measurements during conditioning

Monitor the specimen during the conditioning period to detect any change in status. During the last hour of the conditioning period, subject the specimen to the functional test.

#### 5.5.2.6 Final measurements

After the recovery period, subject the specimen to the functional test and inspect it visually for mechanical damage both externally and internally.

### 5.6 Impact (operational)

#### 5.6.1 Objective of the test

The objective of the test is to demonstrate the immunity of the equipment to mechanical impacts upon the surface which it can sustain in the normal service environment and which it can reasonably be expected to withstand.

#### 5.6.2 Test procedure

##### 5.6.2.1 General

Apply the test apparatus and procedure specified in IEC 60068-2-75.

##### 5.6.2.2 Initial examination

Before conditioning, subject the specimen to the functional test.

##### 5.6.2.3 State of the specimen during conditioning

5.6.2.3.1 Mount the specimen, as specified in [5.1.3](#), and connect it to suitable power-supply, monitoring, and loading equipment (see [5.1.4](#)).

5.6.2.3.2 The specimen shall be in the quiescent condition.

##### 5.6.2.4 Conditioning

5.6.2.4.1 Apply impacts to all surfaces of the specimen that are accessible at access level 1.

5.6.2.4.2 For all such surfaces, three blows shall be applied to any point(s) considered likely to cause damage to or impair the operation of the specimen.

**5.6.2.4.3** Care should be taken to ensure that the results from a series of three blows do not influence subsequent series of blows.

**5.6.2.4.4** In case of doubt, the defect shall be disregarded and a further three blows shall be applied to the same position on a new specimen.

**5.6.2.4.5** Apply the following severity of conditioning:

- impact energy:  $(0,5 \pm 0,04)$  J;
- number of impacts per point: 3.

### **5.6.2.5 Measurements during conditioning**

Monitor the specimen during the conditioning periods to detect any changes in functional condition and to ensure that the results of the three blows do not influence subsequent series of blows.

### **5.6.2.6 Final measurements**

After the conditioning, subject the specimen to the functional test and inspect it visually for mechanical damage both externally and internally.

## **5.7 Vibration, sinusoidal (operational)**

### **5.7.1 Objective of the test**

The objective of the test is to demonstrate the immunity of the equipment to vibrations at levels appropriate to the service environment.

### **5.7.2 Test procedure**

#### **5.7.2.1 General**

**5.7.2.1.1** Use the test procedure specified in IEC 60068-2-6.

**5.7.2.1.2** The vibration operational test can be combined with the vibration endurance test, so that the specimen is subjected to the operational test conditioning followed by the endurance test conditioning in each axis.

#### **5.7.2.2 Initial examination**

Before conditioning, subject the specimen to the functional test.

#### **5.7.2.3 State of the specimen during conditioning**

**5.7.2.3.1** Mount the specimen, as specified in [5.1.3](#), and in accordance with IEC 60068-2-47, and connect it to suitable power-supply, monitoring, and loading equipment (see [5.1.4](#)).

**5.7.2.3.2** Test the specimen in each of the following functional conditions:

- a) quiescent condition;
- b) fire protection condition;
- c) disabled condition.

#### 5.7.2.4 Conditioning

**5.7.2.4.1** Subject the specimen to vibration in each of the three mutually perpendicular axes in turn, one of which is perpendicular to the plane of mounting of the specimen.

**5.7.2.4.2** Apply the following severity of conditioning:

- frequency range: 10 Hz to 150 Hz;
- acceleration amplitude: 0,981 m/s<sup>2</sup> (0,1 g<sub>n</sub>);
- number of axes: 3;
- number of sweep cycles per axis: 1 for each functional condition.

#### 5.7.2.5 Measurements during conditioning

Monitor the specimen during the conditioning periods to detect any changes in functional conditions.

#### 5.7.2.6 Final measurements

After the conditioning, subject the specimen to the functional test and inspect it visually for mechanical damage both externally and internally.

### 5.8 Electromagnetic compatibility (EMC), immunity tests (operational)

**5.8.1** Conduct the following EMC immunity tests as specified in EN 50130-4.

- a) mains supply voltage variations: these tests are included as they should be applied when the power-supply equipment is housed in the FPCE (see ISO 7240-4) or when the FPCE includes other mains inputs for which these tests are applicable;
- b) mains supply voltage dips and interruptions: these tests are included as they should be applied when the power-supply equipment is housed in the FPCE (see ISO 7240-4) or when the FPCE includes other mains inputs for which these tests are applicable;
- c) electrostatic discharge;
- d) radiated electromagnetic fields;
- e) conducted disturbances induced by electromagnetic fields;
- f) fast transient bursts;
- g) slow, high energy voltage surges.

**5.8.2** For the tests of [5.8.1](#), the criteria for compliance specified in EN 50130-4 and the following shall apply:

- a) The functional test, called for in the initial and final measurements, shall be the functional test described in [5.2](#).
- b) The required operating condition shall be as described in [5.1.3](#) and the equipment shall be tested in the quiescent condition.
- c) The connections to the various inputs and outputs shall be made with unscreened cables, unless the manufacturer's installation data specifies that only screened cables shall be used.
- d) In the electrostatic discharge test, the discharges shall be applied to the parts of the equipment accessible at access level 2.

- e) In the fast transient burst test, the transients shall be applied to the AC mains lines by the direct injection method and to the other inputs, signal, data, and control lines by the capacitive clamp method.
- f) If the equipment has a number of identical types of inputs or outputs, then the tests of [5.8.1](#) e), f), and g), and if applicable, a) and b), shall be applied to one of each type.

## 5.9 Supply voltage variation (operational)

### 5.9.1 Objective of the test

The objective of the test is to demonstrate the ability to function correctly over the anticipated range of supply voltage conditions.

### 5.9.2 Test procedure

#### 5.9.2.1 General

**5.9.2.1.1** No reference can be made to an International Standard as of the publication date of this part of ISO 7240.

**5.9.2.1.2** Subject the specimen to each of the specified power-supply conditions until temperature stability is reached and the functional test has been conducted.

#### 5.9.2.2 Initial examination

Before conditioning, subject the specimen to the functional test.

#### 5.9.2.3 State of the specimen during conditioning

**5.9.2.3.1** Mount the specimen, as specified in [5.1.3](#), and connect it to suitable power-supply, monitoring, and loading equipment (see [5.1.4](#)).

**5.9.2.3.2** The specimen shall be in the quiescent condition.

#### 5.9.2.4 Conditioning

Apply the following conditions:

- a) supply of maximum input voltage as specified by the manufacturer;
- b) supply of minimum input voltage as specified by the manufacturer.

Compatibility between the FPCE and any specific type of power supply equipment requires that the range of input voltages specified for the FPCE include the range of output voltages recorded for the power supply equipment in the tests of ISO 7240-4.

#### 5.9.2.5 Measurements during conditioning

Monitor the specimen at the supply-voltage conditions until temperature stability is reached and subject the specimen to the functional test at each voltage condition.

#### 5.9.2.6 Final measurements

After conditioning, subject the specimen to the functional test.

## 5.10 Damp heat, steady-state (endurance)

### 5.10.1 Objective of the test

The objective of the test is to demonstrate the ability of the equipment to withstand the long-term effects of humidity in the service environment (e.g. changes in electrical properties due to absorption, chemical reactions involving moisture, galvanic corrosion, etc.).

### 5.10.2 Test procedure

#### 5.10.2.1 General

Use the test procedure specified in IEC 60068-2-78.

#### 5.10.2.2 Initial examination

Before conditioning, subject the specimen to the functional test.

#### 5.10.2.3 State of the specimen during conditioning

Mount the specimen, as required in [5.1.3](#), and connect it to suitable power-supply, monitoring, and loading equipment (see [5.1.4](#)). The specimen shall not be supplied with power during the conditioning.

#### 5.10.2.4 Conditioning

5.10.2.4.1 Apply the following severity of conditioning:

- temperature:  $(40 \pm 2)$  °C;
- relative humidity:  $(93^{+2}_{-3})$  %;
- duration: 21 d.

5.10.2.4.2 Pre-condition the specimen at the condition temperature  $(40 \text{ °C} \pm 2 \text{ °C})$  until temperature stability has been reached, to prevent the formation of water droplets on the specimen.

#### 5.10.2.5 Final measurements

After the recovery period, subject the specimen to the functional test and inspect it visually for mechanical damage both externally and internally.

## 5.11 Vibration, sinusoidal (endurance)

### 5.11.1 Objective of the test

The objective of the test is to demonstrate the ability of the equipment to withstand the long term effects of vibration at levels appropriate to the environment.

### 5.11.2 Test procedure

#### 5.11.2.1 General

5.11.2.1.1 Use the test procedure specified in IEC 60068-2-6.

**5.11.2.1.2** The vibration endurance test can be combined with the vibration operational test, so that the specimen is subjected to the operational test conditioning followed by the endurance test conditioning in each axis in turn.

#### **5.11.2.2 Initial examination**

Before conditioning, subject the specimen to the functional test.

#### **5.11.2.3 State of the specimen during conditioning**

Mount the specimen as required in [5.1.3](#) and in accordance with IEC 60068-2-47, and connect it to suitable power-supply, monitoring, and loading equipment (see [5.1.4](#)). The specimen shall not be supplied with power during the conditioning.

#### **5.11.2.4 Conditioning**

Subject the specimen to vibration in each of the three mutually perpendicular axes in turn, one of which shall be perpendicular to the plane of mounting of the specimen.

Apply the following severity of conditioning:

- frequency range: 10 Hz to 150 Hz;
- acceleration amplitude: 4,905 m/s<sup>2</sup> (0,5 g<sub>n</sub>);
- number of axes: 3;
- number of sweep cycles: 20 per axis.

#### **5.11.2.5 Final measurements**

After conditioning, subject the specimen to the functional test and inspect it visually for mechanical damage both externally and internally.

## **6 Test report**

The test report shall contain, as a minimum, the following information:

- a) identification of the test specimen;
- b) a reference to this part of ISO 7240 (i.e. ISO 7240-28:2014);
- c) results of the tests: the individual response times and any other data, such as specimen orientation, as specified in the individual tests;
- d) conditioning period and conditioning atmosphere;
- e) temperature and relative humidity in the test room throughout the test;
- f) details of the supply and monitoring equipment and the response criteria;
- g) details of any deviation from this part of ISO 7240 or from the International Standards to which reference is made, and details of any operations regarded as optional.

## **7 Marking**

**7.1** The FPCE shall be marked with the following information, which shall be legible at access level 1:

- a) the number of this part of ISO 7240 (i.e. ISO 7240-28:2014);

- b) the name or trademark of the manufacturer or supplier;
- c) the type number or other designation of the FPCE.

**7.2** It shall be possible to identify a code or number that identifies the production period of the FPCE at access level 2.



## Annex A (informative)

### Explanation of access levels

**A.1** This part of ISO 7240 defines access levels for the indications and controls relating to mandatory functions. In some cases, alternatives are offered (e.g. access level 1 or 2). This is because either can be appropriate in different operational circumstances. The purpose of the different access levels is not defined in this part of ISO 7240. However, in general it is expected that they be used as follows:

- a) access level 1: by members of the general public or persons having a general responsibility for safety supervision, who can be expected to investigate and initially respond to a fire alarm or a fault warning;

**NOTE** It is not intended that controls and indicators be available to members of the general public who are not expected to investigate and respond to a fire alarm or fault warning. Specific requirements for access are generally part of the design solution for the fire detection and alarm system.

- b) access level 2: by persons having a specific responsibility for safety and who are trained and authorized to operate the FPCE in the
- quiescent condition,
  - fire protection condition,
  - fault warning condition,
  - disabled condition, and
  - test condition;
- c) access level 3: by persons who are trained and authorized to
- re-configure the site-specific data held within the FPCE or controlled by it (e.g. labelling, zoning, alarm organization), and
  - maintain the FPCE in accordance with the manufacturer's published instructions and data;
- d) access level 4: by persons who are trained and authorized by the manufacturer either to repair the FPCE or to alter its firmware, thereby changing its basic mode of operation.

**A.2** See [4.8](#) for the minimum requirements for accessibility. Only access levels 1 and 2 have a strict hierarchy. Examples of special procedures for entry to access level 2 and/or to access level 3 are the use of

- mechanical keys,
- keyboard and codes, and
- access cards.

**A.3** Examples of special means for entry to access level 4 are the use of

- mechanical keys,
- tools, and
- external programming devices.

**A.4** It can be acceptable that the entry to access level 4 requires only a simple tool, such as a screwdriver, after access level 2 or 3 has been reached. For example, the manufacturer can declare in his documentation which parts of the FPCE are not user-serviceable, and the entry to access level 4 can then be controlled by management of the user. It is also considered acceptable to use external tools to carry out certain functions at access level 3, e.g. to program site-specific data.

**A.5** It can be desirable in certain circumstances that the FPCE have additional access levels within access level 2, or access level 3 (e.g. 2A and 2B), which permits different classes of authorized user to have access to a selected group of controls or functions. This is not prohibited by this part of the ISO 7240. The exact configuration depends on the type of installation, the way the FPCE is used and the complexity of the functions provided.

## Annex B (informative)

### Design requirements for software-controlled fire protection control equipment

**B.1** FPCE can incorporate software-controlled elements that are required to fulfil mandatory requirements of this part of ISO 7240, but which are supplied to the manufacturer. A good example is an alphanumeric display module but there are many possibilities, including both physical modules and embedded software (e.g. operating systems). Such elements can be traded worldwide as commodity items and detailed software documentation (and, for that matter, details of the hardware design) might not be available to the FPCE manufacturer. It is not the intention of this part of ISO 7240 to prohibit the use of appropriate technology, and in such cases the detailed requirements for documentation and design of [4.15.2](#) and [4.15.3](#) can be relaxed at the discretion of the testing authority. However, it is expected that products from third parties that are designed and produced exclusively for the FPCE be fully documented and fulfil the requirements. It is the responsibility of the manufacturer to ensure that the element is of proven reliability and is suitable for the application. Proven reliability can be assumed if the components under question are freely available on the market and have sufficient field experience (e.g. >1 year). It is necessary that the interface with the main application be clearly and comprehensively specified and that this documentation be available to the testing authority.

**B.2** [4.15.4](#) deals with program monitoring. The program is the software necessary for the FPCE to carry out the mandatory functions, including any declared options with requirements. It is necessary that the execution of the entire program be monitored, and this can include software that runs on more than one processor and software in elements supplied to manufacturers. It is the responsibility of the manufacturer and the testing authority to agree on the necessary degree of monitoring, but in the case of an alphanumeric display module, it is considered sufficient to routinely check that data written to the module can be read back from it.

**B.3** [4.15.5.1](#) requires that all executable code and data necessary to comply with this part of ISO 7240 be held in memory that is capable of continuous, non-maintained, reliable operation for a period of at least 10 years. Memory with moving mechanical parts should be carefully evaluated to ensure sufficient reliability. Tapes, or magnetic or optical data discs for the storage of programs and data, should also be carefully evaluated to ensure sufficient reliability as they also can degrade to the point of failure over 10 years.

