

# INTERNATIONAL STANDARD

**ISO**  
**7240-10**

Second edition  
2012-05-15

---

---

## **Fire detection and alarm systems —**

### **Part 10: Point-type flame detectors**

*Systèmes de détection et d'alarme d'incendie —  
Partie 10: Détecteurs de flammes ponctuels*



Reference number  
ISO 7240-10:2012(E)

© ISO 2012

## ISO 7240-10:2012(E)



### **COPYRIGHT PROTECTED DOCUMENT**

© ISO 2012

All rights reserved. Unless otherwise specified, no part of this publication may be reproduced or utilized in any form or by any means, electronic or mechanical, including photocopying and microfilm, without permission in writing from either ISO at the address below or ISO's member body in the country of the requester.

ISO copyright office  
Case postale 56 • CH-1211 Geneva 20  
Tel. + 41 22 749 01 11  
Fax + 41 22 749 09 47  
E-mail [copyright@iso.org](mailto:copyright@iso.org)  
Web [www.iso.org](http://www.iso.org)

Published in Switzerland

# Contents

Page

Foreword .....	iv
Introduction .....	vi
<b>1 Scope .....</b>	<b>1</b>
<b>2 Normative references .....</b>	<b>1</b>
<b>3 Terms and definitions .....</b>	<b>1</b>
<b>4 Abbreviated terms .....</b>	<b>2</b>
<b>5 General requirements .....</b>	<b>3</b>
<b>5.1 Compliance .....</b>	<b>3</b>
<b>5.2 Classification .....</b>	<b>3</b>
<b>5.3 Individual alarm indication .....</b>	<b>3</b>
<b>5.4 Connection of ancillary devices .....</b>	<b>3</b>
<b>5.5 Monitoring of detachable detectors .....</b>	<b>3</b>
<b>5.6 Manufacturer adjustments .....</b>	<b>3</b>
<b>5.7 On-site sensitivity adjustment .....</b>	<b>4</b>
<b>5.8 Ingress protection (IP) — Optional function .....</b>	<b>4</b>
<b>5.9 Marking .....</b>	<b>4</b>
<b>5.10 Data .....</b>	<b>5</b>
<b>5.11 Requirements for software-controlled detectors .....</b>	<b>5</b>
<b>6 Tests .....</b>	<b>6</b>
<b>6.1 General .....</b>	<b>6</b>
<b>6.2 Reproducibility .....</b>	<b>9</b>
<b>6.3 Repeatability .....</b>	<b>10</b>
<b>6.4 Directional dependence .....</b>	<b>10</b>
<b>6.5 Fire sensitivity .....</b>	<b>11</b>
<b>6.6 Dazzling (operational) .....</b>	<b>14</b>
<b>6.7 Dry heat (operational) .....</b>	<b>15</b>
<b>6.8 Cold (operational) .....</b>	<b>16</b>
<b>6.9 Damp heat, cyclic (operational) .....</b>	<b>16</b>
<b>6.10 Damp heat, steady state (endurance) .....</b>	<b>17</b>
<b>6.11 Sulfur dioxide (SO<sub>2</sub>) corrosion (endurance) .....</b>	<b>18</b>
<b>6.12 Shock (operational) .....</b>	<b>19</b>
<b>6.13 Impact (operational) .....</b>	<b>20</b>
<b>6.14 Vibration, sinusoidal (operational) .....</b>	<b>21</b>
<b>6.15 Vibration, sinusoidal (endurance) .....</b>	<b>22</b>
<b>6.16 Variation of supply parameters (operational) .....</b>	<b>23</b>
<b>6.17 EMC immunity tests (operational) .....</b>	<b>23</b>
<b>6.18 IP — Optional function .....</b>	<b>24</b>
<b>7 Test report .....</b>	<b>25</b>
<b>Annex A (normative) Apparatus for response point determination .....</b>	<b>26</b>
<b>Annex B (normative) Liquid (heptane) fire (TF5) .....</b>	<b>28</b>
<b>Annex C (normative) Liquid (methylated spirit) fire (TF6) .....</b>	<b>29</b>
<b>Annex D (normative) Apparatus for dazzling test .....</b>	<b>30</b>
<b>Annex E (normative) Apparatus for impact test .....</b>	<b>31</b>
<b>Annex F (informative) Example of methane burner .....</b>	<b>33</b>

## ISO 7240-10:2012(E)

### Foreword

ISO (the International Organization for Standardization) is a worldwide federation of national standards bodies (ISO member bodies). The work of preparing International Standards is normally carried out through ISO technical committees. Each member body interested in a subject for which a technical committee has been established has the right to be represented on that committee. International organizations, governmental and non-governmental, in liaison with ISO, also take part in the work. ISO collaborates closely with the International Electrotechnical Commission (IEC) on all matters of electrotechnical standardization.

International Standards are drafted in accordance with the rules given in the ISO/IEC Directives, Part 2.

The main task of technical committees is to prepare International Standards. Draft International Standards adopted by the technical committees are circulated to the member bodies for voting. Publication as an International Standard requires approval by at least 75 % of the member bodies casting a vote.

Attention is drawn to the possibility that some of the elements of this document may be the subject of patent rights. ISO shall not be held responsible for identifying any or all such patent rights.

ISO 7240-10 was prepared by Technical Committee ISO/TC 21, *Equipment for fire protection and fire fighting*, Subcommittee SC 3, *Fire detection and alarm systems*.

This second edition cancels and replaces the first edition (ISO 7240-10:2007), which has been technically revised.

ISO 7240 consists of the following parts, under the general title *Fire detection and alarm systems*:

- *Part 1: General and definitions*
- *Part 2: Control and indicating equipment*
- *Part 3: Audible alarm devices*
- *Part 4: Power supply equipment*
- *Part 5: Point-type heat detectors*
- *Part 6: Carbon monoxide fire detectors using electro-chemical cells*
- *Part 7: Point-type smoke detectors using scattered light, transmitted light or ionization*
- *Part 8: Carbon monoxide fire detectors using an electro-chemical cell in combination with a heat sensor*
- *Part 9: Test fires for fire detectors* [Technical Specification]
- *Part 10: Point-type flame detectors*
- *Part 11: Manual call points*
- *Part 12: Line type smoke detectors using a transmitted optical beam*
- *Part 13: Compatibility assessment of system components*
- *Part 14: Guidelines for drafting codes of practice for design, installation and use of fire detection and fire alarm systems in and around buildings* [Technical Report]
- *Part 15: Point type fire detectors using scattered light, transmitted light or ionization sensors in combination with a heat sensor*
- *Part 16: Sound system control and indicating equipment*
- *Part 17: Short-circuit isolators*
- *Part 18: Input/output devices*
- *Part 19: Design, installation, commissioning and service of sound systems for emergency purposes*

- *Part 20: Aspirating smoke detectors*
- *Part 21: Routing equipment*
- *Part 22: Smoke-detection equipment for ducts*
- *Part 23: Visual alarm devices*
- *Part 24: Sound-system loudspeakers*
- *Part 25: Components using radio transmission paths*
- *Part 27: Point-type fire detectors using a scattered-light, transmitted-light or ionization smoke sensor, an electrochemical-cell carbon-monoxide sensor and a heat sensor*
- *Part 28: Fire protection control equipment*

## **ISO 7240-10:2012(E)**

### **Introduction**

A fire detection and fire alarm system is required to function satisfactorily, not only in the event of a fire, but also during and after exposure to conditions likely to be met in practice, such as corrosion, vibration, direct impact, indirect shock and electromagnetic interference. Some tests specified in this part of ISO 7240 are intended to assess the performance of the fire detectors under such conditions.

# Fire detection and alarm systems —

## Part 10: Point-type flame detectors

### 1 Scope

This part of ISO 7240 specifies requirements, test methods and performance criteria for point-type, resettable flame detectors that operate using radiation from a flame for use in fire detection systems installed in buildings.

This part of ISO 7240 is not applicable to flame detectors with special characteristics, developed for specific risks. It can be used as guidance in assessing other types of flame detectors not included in this part of ISO 7240.

The performance of flame detectors is assessed from results obtained in specific tests. This part of ISO 7240 is not intended to place any other restrictions on the design and construction of such flame detectors.

### 2 Normative references

The following referenced documents are indispensable for the application of this document. For dated references, only the edition cited applies. For undated references, the latest edition of the referenced document (including any amendments) applies.

ISO 209, *Aluminium and aluminium alloys — Chemical composition*

ISO 7240-1, *Fire detection and alarm systems — Part 1: General and definitions*

IEC 60064, *Tungsten filament lamps for domestic and similar general lighting purposes — Performance requirements*

IEC 60068-1, *Environmental testing — Part 1: General and guidance*

IEC 60068-2-1, *Environmental testing — Part 2-1: Tests — Test A: Cold*

IEC 60068-2-2, *Environmental testing — Part 2-2: Tests — Test B: Dry heat*

IEC 60068-2-6, *Environmental testing — Part 2-6: Tests — Test Fc: Vibration (sinusoidal)*

IEC 60068-2-27, *Environmental testing — Part 2-27: Tests — Test Ea and guidance: Shock*

IEC 60068-2-30, *Environmental testing — Part 2-30: Tests — Test Db: Damp heat, cyclic (12 h + 12 h cycle)*

IEC 60068-2-42, *Environmental testing — Part 2-42: Tests — Test Kc: Sulphur dioxide test for contacts and connections*

IEC 60068-2-78, *Environmental testing — Part 2-78: Tests — Test Cab: Damp heat, steady state*

IEC 60529, *Degrees of protection provided by enclosures (IP Code)*

EN 50130-4, *Alarm systems — Part 4: Electromagnetic compatibility — Product family standard: Immunity requirements for components of fire, intruder, hold up, CCTV, access control and social alarm systems*

### 3 Terms and definitions

For the purposes of this document, the terms and definitions given in ISO 7240-1 and the following apply.

## ISO 7240-10:2012(E)

### 3.1

#### **detector classification**

classification of flame detectors to indicate their relative sensitivity to fire

NOTE Class 1 indicates the highest sensitivity acceptable and class 3 the lowest sensitivity acceptable within this part of ISO 7240, except for class 4 where the sensitivity is decided by the manufacturer.

### 3.2

#### **infrared (IR) detector**

flame detector responding only to radiation having wavelengths greater than 850 nm

### 3.3

#### **multiband detector**

flame detector that responds to radiation in more than one distinct wavelength range where each range may contribute to the alarm decision

NOTE The alarm decision may be based on any arithmetic or logical combination of the individual signals.

### 3.4

#### **response point**

*D*

distance at which the individual flame detector under test gives an alarm signal

NOTE The distance, *D*, is measured in accordance with 6.1.5.

### 3.5

#### **sensitivity**

measure of the ability of a flame detector to detect fires

NOTE Sensitivity is not necessarily directly related to the response point.

### 3.6

#### **sensitivity adjustment**

any adjustment of the detector or of the alarm criteria within the supply and monitoring equipment that leads to a change in sensitivity

NOTE See 6.1.2.

### 3.7

#### **type A**

device with no specific ingress protection (IP) rating

### 3.8

#### **type B**

device with ingress protection (IP) rating of IP54C

### 3.9

#### **ultra-violet (UV) detector**

flame detector responding only to radiation having wavelengths less than 300 nm

## 4 Abbreviated terms

- EMC electromagnetic compatibility
- IP ingress protection
- IR infrared
- UV ultra-violet



## 5 General requirements

### 5.1 Compliance

In order to comply with this part of ISO 7240, the detector shall meet the requirements of Clause 5, which shall be verified visually or by engineering assessment. The detector shall be tested and shall meet the requirements of the tests as specified in Clause 6 .

### 5.2 Classification

Detectors shall conform to one or more of the following classifications to which the manufacturer claims compliance (see Table 1) and according to the requirements of the tests specified in 6.5.

**Table 1 — Flame detector classifications**

Class	Classification distance m
1	25
2	17
3	12
4	decided by the manufacturer

NOTE Detectors may be classified into more than one class, depending on the results of the assessment.

### 5.3 Individual alarm indication

**5.3.1** Each detector shall be provided with an integral red visual indicator, by which the individual detector that released an alarm can be identified, until the alarm condition is reset. Where other conditions of the detector are visually indicated, they shall be clearly distinguishable from the alarm indication, except when the detector is switched into a service mode. For a detachable detector, the indicator may be integral with the base or the detector head.

**5.3.2** The visual indicator shall be visible from a distance of 6 m in an ambient light intensity up to 500 lx at an angle of up to:

- a) 5° from the axis of the detector in any direction, and
- b) 45° from the axis of the detector in at least one direction.

### 5.4 Connection of ancillary devices

The detector may provide for connections to ancillary devices (remote indicators, control relays, etc.), but open- or short-circuit failures of these connections shall not prevent the correct operation of the detector.

### 5.5 Monitoring of detachable detectors

For detachable detectors, a means shall be provided for a remote monitoring system (e.g. the control and indicating equipment) to detect the removal of the head from the base, in order to give a fault signal.

### 5.6 Manufacturer adjustments

It shall not be possible to change the manufacturer's settings except by special means (e.g. the use of a special code or tool) or by breaking or removing a seal.

## ISO 7240-10:2012(E)

### 5.7 On-site sensitivity adjustment

If there is provision for on-site sensitivity adjustment of the detector, then:

- a) for all settings at which the manufacturer claims compliance, the detector shall comply with the requirements of this part of ISO 7240 and shall achieve a classification corresponding to that marked on the detector for that setting;
- b) for each setting in a), access to the adjustment means shall be possible only by the use of a code or special tool or by removing the detector from its base or mounting;
- c) any setting or settings at which the manufacturer does not claim compliance with this part of ISO 7240 shall only be accessible by the use of a code or special tool, and it shall be clearly marked on the detector or in the associated data that if these setting or settings are used, the detector does not comply with this part of ISO 7240.

NOTE These adjustments can be carried out on the detector or on the control and indicating equipment.

### 5.8 Ingress protection (IP) — Optional function

The IP category (i.e. IP rating) of the detector shall be specified by the manufacturer. No requirement shall apply to type A flame detectors. Type B flame detectors shall comply with rating IP54C of IEC 60529 (see 6.18).

### 5.9 Marking

**5.9.1** Each detector shall be clearly marked with, or supplied with, the following information:

- a) reference to this part of ISO 7240, i.e. ISO 7240-10:2012;
- b) name or trademark of the manufacturer or supplier;
- c) model designation (type or number);
- d) classification of the detector, e.g. class 1 (where the detector is classified as class 4, indicate class 4 and the distance as determined by 6.5.2.3);
- e) IP rating (if applicable).
- f) mark(s) or code(s), e.g. a serial number or batch code, by which the manufacturer can identify, at least, the date or batch and place of manufacture and the version number(s) of any software contained within the detector;
- g) wiring terminal designations;
- h) angle of reception as determined in 6.4;
- i) operating wavelength band(s), e.g. UV, IR.

**5.9.2** For detachable detectors, the detector head shall be marked with at least a), b), c), d), e), f), h) and i) from 5.9.1, and the base shall be marked with at least c), i.e. its own model designation, and g).

**5.9.3** Where any marking on the device uses symbols or abbreviations not in common use, these shall be explained in the data supplied with the device.

**5.9.4** The marking shall be visible during installation of the detector and shall be accessible during maintenance.

**5.9.5** The markings shall not be placed on screws or other easily removable parts.

## 5.10 Data

**5.10.1** Detectors shall either be supplied with sufficient technical, installation and maintenance data to enable their correct installation and operation or, if all of these data are not supplied with each detector, reference to the appropriate data sheet shall be given on, or with, each detector.

**5.10.2** To enable correct operation of the detectors, these data should describe the requirements for the correct processing of the signals from the detector. This may be in the form of a full technical specification of these signals, a reference to the appropriate signalling protocol or a reference to suitable types of control and indicating equipment, etc.

**5.10.3** Installation and maintenance data shall include reference to an *in situ* test method to ensure that detectors operate correctly when installed.

NOTE Additional information can be required by organizations certifying that detectors produced by a manufacturer conform to the requirements of this part of ISO 7240.

## 5.11 Requirements for software-controlled detectors

### 5.11.1 General

For detectors that rely on software control, the requirements of 5.11.2, 5.11.3 and 5.11.4 shall be met in order to fulfil the requirements of this part of ISO 7240.

### 5.11.2 Software documentation

**5.11.2.1** The manufacturer shall submit documentation that gives an overview of the software design. This documentation shall be in sufficient detail for the design to be inspected for compliance with this part of ISO 7240 and shall include at least the following:

- a) functional description of the main program flow (e.g. as a flow diagram or structogram), including a brief description of
  - 1) the modules and the functions that they perform,
  - 2) the way in which the modules interact,
  - 3) the overall hierarchy of the program,
  - 4) the way in which the software interacts with the hardware of the detector,
  - 5) the way in which the modules are called, including any interrupt processing;
- b) description of those areas of memory used for each purpose (e.g. the program, site-specific data and running data);
- c) designation by which the software and its version can be uniquely identified.

**5.11.2.2** The manufacturer shall prepare and maintain detailed design documentation. This shall be available for inspection in a manner that respects the manufacturer's rights for confidentiality. It shall comprise at least the following:

- a) overview of the whole system configuration, including all software and hardware components;
- b) description of each module of the program, containing at least:
  - 1) the name of the module,
  - 2) a description of the tasks performed,

## ISO 7240-10:2012(E)

- 3) a description of the interfaces, including the type of data transfer, the valid data range and the checking for valid data;
- c) full source code listings, as hard copy or in machine-readable form (e.g. ASCII-code), including all global and local variables, constants and labels used, and sufficient comment for the program flow to be recognized;
- d) details of any software tools used in the design and implementation phase (CASE-Tools, Compilers, etc.).

NOTE This detailed design documentation can be reviewed at the manufacturer's premises.

### 5.11.3 Software design

In order to ensure the reliability of the detector, the following requirements for software design apply.

- a) The software shall have a modular structure.
- b) The design of the interfaces for manually and automatically generated data shall not permit invalid data to cause error in the program operation.
- c) The software shall be designed to avoid the occurrence of deadlock of the program flow.

### 5.11.4 Storage of programs and data

**5.11.4.1** The program used to comply with this part of ISO 7240 and any preset data, such as manufacturer's settings, shall be held in non-volatile memory. Writing to areas of memory containing this program and data shall be possible only by the use of a special tool or code and shall not be possible during normal operation of the detector.

**5.11.4.2** Site-specific data shall be held in memory that retains data for at least two weeks without external power to the detector, unless provision is made for the automatic renewal of such data, following loss of power, within 1 h of power being restored.

## 6 Tests

### 6.1 General

#### 6.1.1 Atmospheric conditions for tests

**6.1.1.1** Unless otherwise stated in a test procedure, carry out the testing after the test specimen has been allowed to stabilize in the standard atmospheric conditions for testing as specified in IEC 60068-1 as follows.

- temperature: (15 to 35) °C;
- relative humidity: (25 to 75) %;
- air pressure: (86 to 106) kPa.

**6.1.1.2** The temperature and humidity shall be substantially constant for each environmental test where the standard atmospheric conditions are applied.

#### 6.1.2 Operating conditions for tests

**6.1.2.1** If a test method requires a specimen to be operational, then connect the specimen to suitable supply and monitoring equipment having the characteristics required by the manufacturer's data. Unless otherwise specified in the test method, the supply parameters applied to the specimen shall be set within the manufacturer's specified range(s) and shall remain substantially constant throughout the tests. The value chosen for each parameter shall normally be the nominal value, or the mean of the specified range. If a test procedure requires a specimen to be monitored to detect any alarm or fault signals, then connections shall be made to any necessary

ancillary devices, e.g. through wiring to an end-of-line device for collective (conventional) detectors, to allow a fault signal to be recognized.

**6.1.2.2** Unless otherwise specified in the test method, detectors having adjustable sensitivity shall be set to their highest sensitivity for the conditioning.

**6.1.2.3** The details of the supply and monitoring equipment and the alarm criteria used shall be given in the test report (see Clause 7).

### **6.1.3 Mounting arrangements**

The specimen shall be mounted by its normal means of attachment in accordance with the manufacturer's instructions. If these instructions describe more than one method of mounting, then the method considered to be most unfavourable shall be chosen for each test.

### **6.1.4 Tolerances**

**6.1.4.1** Unless otherwise stated, the tolerances for the environmental test parameters shall be as given in the basic reference standards for the test, e.g. the relevant part of IEC 60068.

**6.1.4.2** If a specific tolerance or deviation limit is not specified in a requirement or test procedure, then a tolerance of  $\pm 5\%$  shall be applied.

### **6.1.5 Determination of response point**

#### **6.1.5.1 Principle**

The response point shall be measured by exposing the detector to the radiation from a suitable flame source and determining the greatest distance at which the detector reliably produces an alarm condition within 30 s of being exposed to the radiation from the flame.

#### **6.1.5.2 Test apparatus**

**6.1.5.2.1** The test apparatus shall be as described in Annex A. The design and construction of the apparatus and the surfaces surrounding the test area shall be such that no significant radiation from the source reaches the detector apart from that which has passed through the aperture. This means for example that there shall be no reflection of radiation from the walls or other parts of the apparatus and no spurious radiation from hot flue gases or hot surfaces around the burner.

**6.1.5.2.2** Throughout this test method, the detector shall be aligned relative to its optical axis and the distances relative to the plane of the detector sensing elements shall be measured. If the detector does not have a well defined optical axis, then the manufacturer shall nominate an optical axis for the purposes of this test method. The position of this axis relative to an easily identifiable plane on the detector shall be noted in the test report (see Clause 7). Similarly, if the detector sensing elements do not lie in a well defined plane, then the manufacturer shall nominate a plane for the purposes of this test method. The position of this plane relative to an easily identifiable plane on the detector shall be noted in the test report (see Clause 7).

#### **6.1.5.3 Initial determination**

A suitable area for the aperture shall be determined experimentally before the commencement of the test program such that the response point of one detector, chosen at random from the specimens submitted for test, lies within the range 1 300 mm to 1 700 mm. The size and shape of the aperture used shall be recorded and shall be kept constant throughout the test program. For detectors having adjustable sensitivity and whose adjustment range covers more than one sensitivity class, the appropriate aperture size for each sensitivity class of detector shall be determined.

## ISO 7240-10:2012(E)

### 6.1.5.4 Source stability

After determining a suitable aperture size and before any determination of response points, the irradiance on the optical axis of the source shall be measured using the radiometer in accordance with Clause A.5. This measurement shall be carried out with no modulation of the source and with the aperture unobstructed. The measured value of irradiance shall be recorded and used as a reference throughout the test program to verify that the source radiance has not varied by more than 5 %.

### 6.1.6 Test procedure

**6.1.6.1** Connect the specimen to its supply and indicating equipment and allow it to stabilize for a period of 15 min or for a time specified by the manufacturer. During this stabilization period, shield the specimen using the shutter in accordance with Clause A.3 from all sources of radiation which can affect the determination of the response point.

**6.1.6.2** Before commencing any measurement of the response point, allow the burner to reach a stable working condition.

**6.1.6.3** Vary the distance of the specimen from the source and expose the detector to the source at each distance for 30 s using the shutter. The response point,  $D$ , is the greatest distance, measured between the aperture and the plane of the specimen sensing element(s), at which the detector reliably produces an alarm response within each 30 s exposure. If the detector response is known to be dependent on previous exposure to radiation, then allow sufficient time before each exposure to ensure that previous exposures do not substantially affect the measurement of the response point.

**6.1.6.4** For detectors having stochastic response behaviour, each value of  $D$  shall be the mean value of at least six repetitions of each measurement. Continue repetitions until an additional value changes the average value of  $D$  by less than 5 %.

### 6.1.7 Reduced functional tests

Where the test procedure calls for a reduced functional test, the detector shall be exposed to a source of radiation that is sufficient to cause an alarm response from the detector. The nature of the source used and the duration of the exposure shall be appropriate to the product in question.

### 6.1.8 Provision for tests

**6.1.8.1** The following shall be provided for testing compliance with this part of ISO 7240:

- a) for detachable detectors, eight heads and eight bases; for non-detachable detectors, eight specimens;
- b) the data required in 5.10.

**6.1.8.2** The specimens submitted shall be deemed representative of the manufacturer's normal production with regard to their construction and calibration. This implies that the mean response point of the eight specimens found in the reproducibility test (6.2) should also represent the production mean and that the limits specified in the reproducibility test should also be applicable to the manufacturer's production.

### 6.1.9 Test schedule

The detectors shall be tested according to the test schedule given in Table 2. After the reproducibility test, the four specimens having the largest value of response point (at the highest sensitivity setting) shall be numbered 1 to 4 and the remainder shall be numbered 5 to 8.

Table 2 — Test schedule

Test	Subclause	Specimen number(s)
Reproducibility	6.2	all specimens
Repeatability	6.3	1
Directional dependence	6.4	1
Fire sensitivity	6.5	all specimens
Dazzling (operational)	6.6	1
Dry heat (operational)	6.7	2
Cold (operational)	6.8	2
Damp heat, cyclic (operational)	6.9	6
Damp heat, steady state (endurance)	6.10	6
Sulphur dioxide (SO <sub>2</sub> ) corrosion (endurance)	6.11	5
Shock (operational)	6.12	8
Impact (operational)	6.13	7
Vibration, sinusoidal (operational)	6.14	4
Vibration, sinusoidal (endurance)	6.15	4
Variation in supply parameters (operational)	6.16	1
Electromagnetic compatibility (EMC) immunity tests (operational)	6.17	
Electrostatic discharge		1 <sup>a</sup>
Radiated electromagnetic fields		3 <sup>a</sup>
Conducted disturbances induced by electromagnetic fields		3 <sup>a</sup>
Fast transient bursts		3 <sup>a</sup>
Slow high-energy voltage surges		2 <sup>a</sup>
Ingress protection — Optional function	6.18	5

<sup>a</sup> In the interest of test economy, it is permitted to use the same specimen for more than one EMC test. In that case, the intermediate functional test(s) on the specimen(s) used for more than one test can be deleted and the full functional test conducted at the end of the sequence of tests. However, it should be noted that in the event of a failure, it might not be possible to identify which test exposure caused the failure.

### 6.1.10 Test report

The test results shall be reported in accordance with Clause 7.

## 6.2 Reproducibility

### 6.2.1 Object of test

To show that the sensitivity of the specimen does not vary unduly from specimen to specimen and to establish response point data for comparison with the response points measured after the environmental tests.

### 6.2.2 Test procedure

**6.2.2.1** Measure the response point of each of the test specimens as specified in 6.1.6 and record each value of *D*. For detectors having adjustable sensitivity and whose range of adjustment covers more than one sensitivity class, repeat the measurement for each marked class.

**6.2.2.2** Calculate the mean of these response points, which shall be designated  $\bar{D}$ .

## ISO 7240-10:2012(E)

**6.2.2.3** For each class setting, designate the maximum response point as  $D_{\max}$ , the lowest response point as  $D_{\min}$ , and the mean as  $\bar{D}$ .

### 6.2.3 Requirements

For each class setting, the ratio  $D_{\max} : \bar{D}$  shall not be greater than 1,15 and the ratio  $\bar{D} : D_{\min}$  shall not be greater than 1,22.

## 6.3 Repeatability

### 6.3.1 Object of test

To show that the specimen has a stable behaviour with respect to its response point even after a number of alarm conditions.

### 6.3.2 Test procedure

**6.3.2.1** Measure the response point of the specimen to be tested six times as specified in 6.1.6.

**6.3.2.2** Designate the maximum response point as  $D_{\max}$ , the minimum value as  $D_{\min}$ .

### 6.3.3 Requirements

The ratio of the response points  $D_{\max} : D_{\min}$  shall not be greater than 1,14.

## 6.4 Directional dependence

### 6.4.1 Object of test

To show that the sensitivity of the specimen is not unduly dependent on the direction of the radiation incident on the specimen.

### 6.4.2 Test procedure

**6.4.2.1** Mount the specimen on the optical bench with its optical axis coincident with the source optical axis as shown in Figure 1. Rotate the specimen through an angle,  $\alpha$ , about an axis normal to the optical axis and passing through the point of intersection of the optical axis and the plane of the sensing element(s). Measure the response value of the specimen as:

$$\alpha = 15^\circ, 30^\circ, \dots, \alpha_{\max}$$

where  $\alpha_{\max}$  is the maximum half-angle of reception specified for that detector type by the manufacturer.

**6.4.2.2** With the angle,  $\alpha$ , set to  $\alpha_{\max}$ , rotate the specimen about its optical axis through an angle,  $\beta$ , and measure the response point a further seven times:

$$\beta = 45^\circ, 90^\circ, 135^\circ, 180^\circ, 225^\circ, 270^\circ, 315^\circ$$

**6.4.2.3** Designate the maximum value of response value at any angle in this test and that measured for the same specimen in the reproducibility test as  $D_{\max}$ , and the minimum value as  $D_{\min}$ .

### 6.4.3 Requirements

The ratio of the response points  $D_{\max} : D_{\min}$  shall not be greater than 1,41.



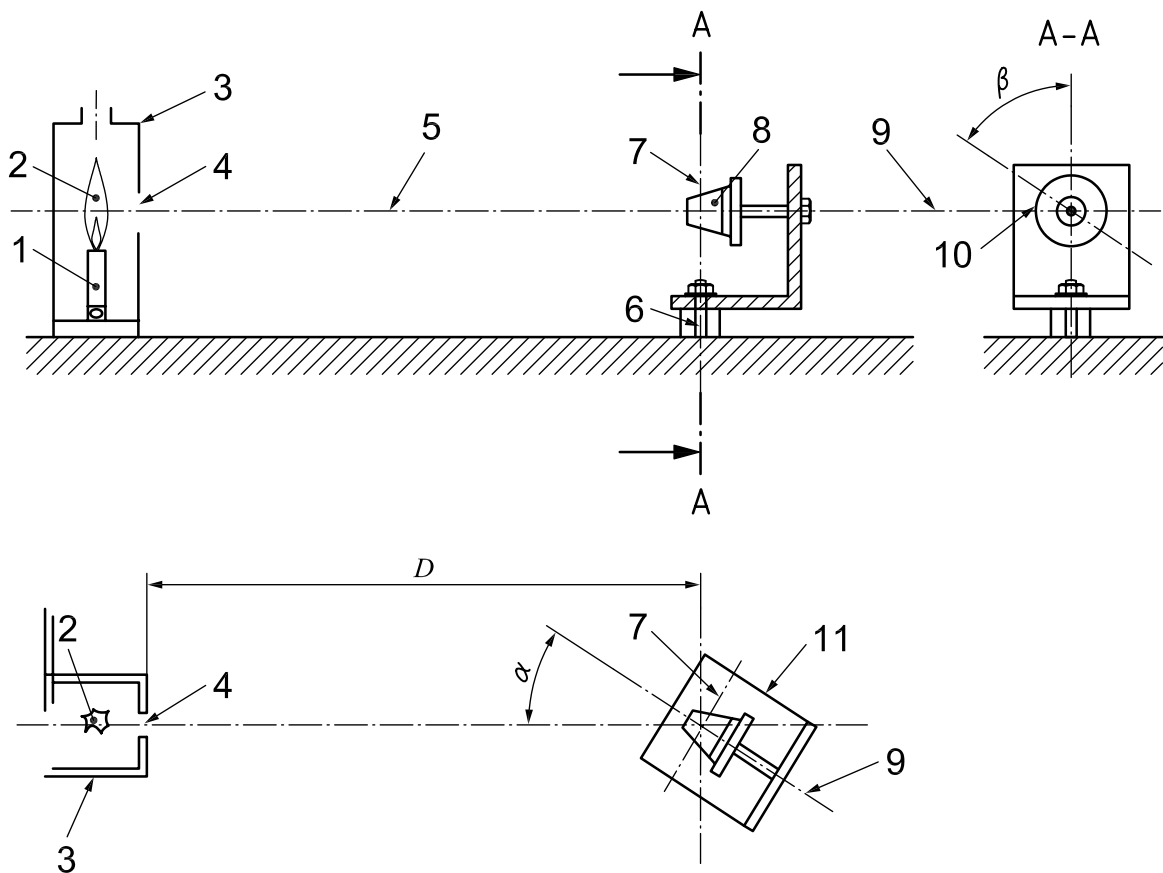

**Key**

- 1 methane gas burner
- 2 flame
- 3 burner housing
- 4 aperture
- 5 optical axis
- 6 vertical rotating axis
- 7 plane of sensing element(s)
- 8 detector
- 9 horizontal rotating axis
- 10 reference point
- 11 detector support
- D* response point

**Figure 1 — Measurement of directional dependence**

## 6.5 Fire sensitivity

### 6.5.1 Object of test

To show that the specimen has adequate sensitivity to fire as required for general application in fire detection systems for buildings, and to determine the sensitivity class or sensitivity classes appropriate for the detector.

## ISO 7240-10:2012(E)

### 6.5.2 Test procedure

#### 6.5.2.1 Principle of test

The test consists of exposing the detectors to the radiation of two types of test fire at known distances,  $d$ , to determine if the detectors are capable of producing an alarm signal within 30 s. The distance shall be chosen in accordance with the manufacturer's specification for the intended class or classes of the detector (see 6.5.3).

#### 6.5.2.2 Mounting of specimens

**6.5.2.2.1** Mount the eight specimens on a support, with their optical axes in the horizontal plane and at a height of  $1,5\text{ m} \pm 0,2\text{ m}$ . The horizontal angle of incidence,  $I_H$ , as defined in Figure 2, shall be not greater than  $5^\circ$ .

**6.5.2.2.2** Connect each specimen to its supply and monitoring equipment as specified in 6.1.2, and allow it to stabilize in its quiescent condition for at least 15 min before the start of each test fire or for a period specified by the manufacturer.

**6.5.2.2.3** Ensure that the area is free of radiation sources and draughts that can affect the response of the detectors to the test fire.

#### 6.5.2.3 Test fires

**6.5.2.3.1** If the manufacturer specifies class 1, perform the procedure specified in 6.5.2.3.5 to 6.5.2.3.11 with the distance between the fire and the detectors of 25 m from the plane of the detector sensing elements.

**6.5.2.3.2** If the manufacturer specifies class 2, perform the procedure specified in 6.5.2.3.5 to 6.5.2.3.11 with the distance between the fire and the detectors of 17 m from the plane of the detector sensing elements.

**6.5.2.3.3** If the manufacturer specifies class 3, perform the procedure specified in 6.5.2.3.5 to 6.5.2.3.11 with the distance between the fire and the detectors of 12 m from the plane of the detector sensing elements.

**6.5.2.3.4** If the manufacturer specifies class 4, perform the procedure specified in 6.5.2.3.5 to 6.5.2.3.11 with the distance between the fire and the detectors specified by the manufacturer from the plane of the detector sensing elements.

**6.5.2.3.5** Place the fire tray containing *n*-heptane in accordance with Annex B.

**6.5.2.3.6** Shield the specimen from the fire tray.

**6.5.2.3.7** Ignite the fuel and allow it to burn for at least 1 min.

**6.5.2.3.8** Remove the shutter and allow the detectors to be exposed to the radiation from the fire for a period of 30 s. At the end of the 30 s period, shield the detectors from the fire radiation.

**6.5.2.3.9** Record the status of each detector during the test.

**6.5.2.3.10** If all eight specimens are in the alarm condition, then the detector shall be deemed to respond to the test fire. If one or more of the specimens has failed to respond, then the detector is deemed to have failed the test.

**6.5.2.3.11** Repeat the procedure specified in 6.5.2.3.5 to 6.5.2.3.10 using the methylated spirit fire, in accordance with Annex C.

**6.5.2.3.12** For detectors having adjustable sensitivity, repeat the above tests for the extreme sensitivity settings. If the range of adjustment covers more than one sensitivity class, conduct the tests for settings corresponding to each of the marked classes [see 5.7 a)].

### 6.5.3 Classification

Classify the detector according to the greatest distance at which all eight specimens respond to each fire type within the 30 s exposure. At each tested setting for which the manufacturer claims compliance with this part of ISO 7240, classify the detector response as class 1, 2, 3 or 4 (see 5.2).

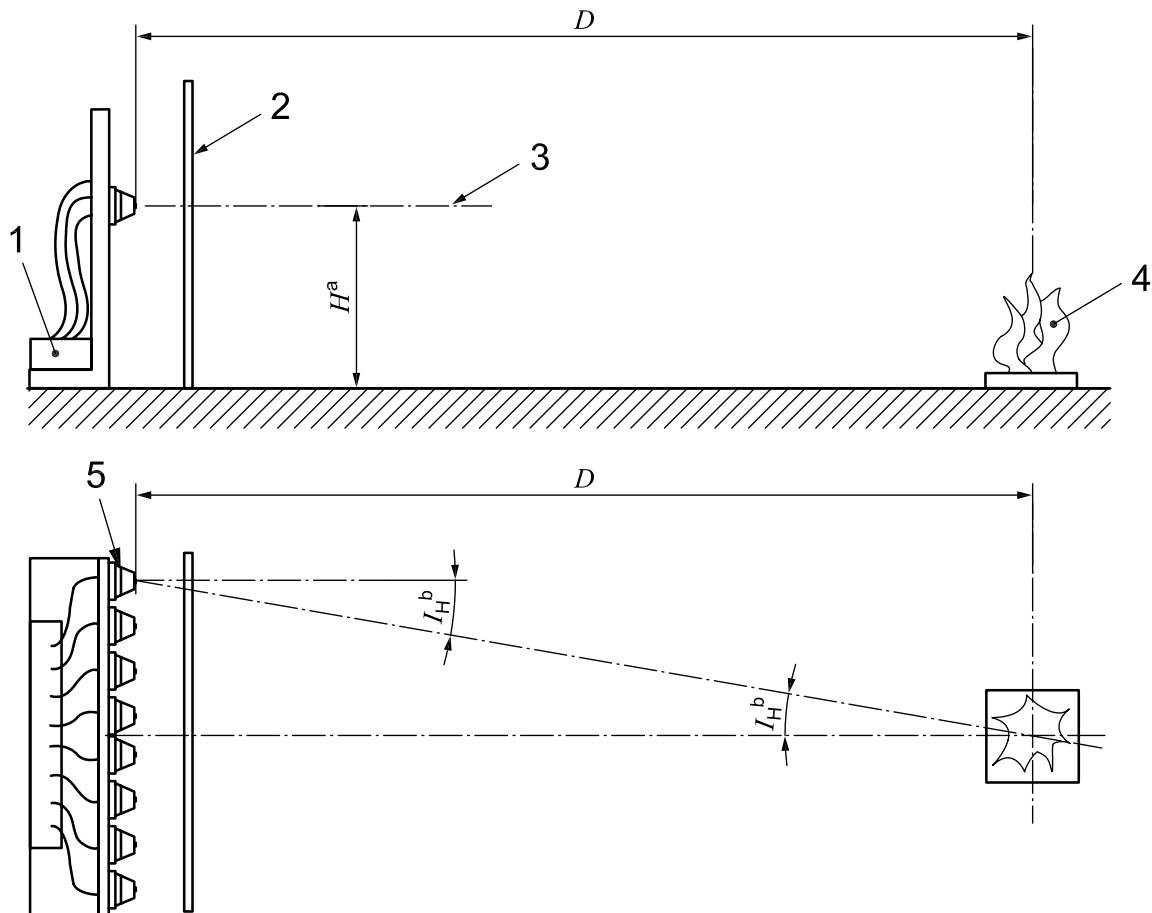

#### Key

- 1 supply and monitoring equipment
- 2 screen to be removed during test
- 3 horizontal optical axis of detectors
- 4 test fire
- 5 detectors
- $D$  response point
- a  $H = 1,5 \text{ m} \pm 0,2 \text{ m}$ .
- b  $I_H = 0^\circ \pm 5^\circ$ .

Figure 2 — Fire sensitivity test

### 6.5.4 Requirements

**6.5.4.1** The detector shall attain classification 1, 2, 3 or 4.

## ISO 7240-10:2012(E)

**6.5.4.2** For detectors having adjustable sensitivity, and for which the adjustment covers more than one sensitivity class, the sensitivity class determined at each setting shall correspond to that marked on the detector.

## 6.6 Dazzling (operational)

### 6.6.1 Object of test

To show that the sensitivity of the specimen is not unduly influenced by the close proximity of artificial light sources.

### 6.6.2 Test procedure and apparatus

#### 6.6.2.1 Reference

Use the test apparatus and perform the procedure described in Annex D and 6.6.2.2 to 6.6.2.6.

#### 6.6.2.2 State of the specimen during conditioning

Mount the specimen on the optical bench as described in 6.1.3 and connect it to its supply and indicating equipment as specified in 6.1.2.

#### 6.6.2.3 Conditioning

Condition the specimen in a darkened room for 1 h and then perform the following procedure.

- a) Switch the lamp ON for 1 s and then OFF for 1 s. Repeat 20 times.
- b) Switch the lamp ON for 2 h.

#### 6.6.2.4 Measurements during conditioning

Monitor the specimen during the conditioning period to detect any alarm or fault signals.

#### 6.6.2.5 Final measurement (light source on)

**6.6.2.5.1** Immediately after the continuous exposure [see 6.6.2.3 b)], and with the light source still ON, determine the response point in accordance with 6.1.6.

**6.6.2.5.2** Designate the greater of the response points measured in this test and that measured for the same specimen in the reproducibility test as  $D_{\max}$ , and the lesser as  $D_{\min}$ .

#### 6.6.2.6 Final measurement (light source off)

**6.6.2.6.1** Immediately after the completion of the measurement in 6.6.2.5, switch the light source OFF and allow the specimen to recover for 5 min. At the end of the recovery period, determine the response point in accordance with 6.1.6.

**6.6.2.6.2** Designate the greater of the response points measured in this test and that measured for the same specimen in the reproducibility test as  $D_{\max}$ , and the lesser as  $D_{\min}$ .

### 6.6.3 Requirements

**6.6.3.1** No alarm or fault signals shall be given during exposures a) and b) of 6.6.2.3.

**6.6.3.2** The ratio of the response point values  $D_{\max}:D_{\min}$  determined in 6.6.2.5 shall not be greater than 1,26.

**6.6.3.3** The ratio of the response point values  $D_{\max}$ :  $D_{\min}$  determined in 6.6.2.6 shall not be greater than 1,14.

## **6.7 Dry heat (operational)**

### **6.7.1 Object of test**

To demonstrate the ability of the specimen to function correctly at high ambient temperatures appropriate to the anticipated service environment.

### **6.7.2 Test procedure and apparatus**

#### **6.7.2.1 General**

Use the test apparatus and perform the procedure as specified in IEC 60068-2-2, Test Ba or Bb, and 6.7.2.2 to 6.7.2.4.

#### **6.7.2.2 State of the specimen during conditioning**

Mount the specimen as specified in 6.1.3 and connect it to supply and monitoring equipment as specified in 6.1.2.

#### **6.7.2.3 Conditioning**

Apply the following conditioning:

- temperature: Starting at an initial air temperature of  $(23 \pm 5) ^\circ\text{C}$ , increase the air temperature to  $(55 \pm 2) ^\circ\text{C}$ .
- duration: Maintain the temperature for 16 h.

NOTE Test Bb specifies rates of change of temperature of  $\leq 1 ^\circ\text{C}/\text{min}$  for the transitions to and from the conditioning temperature.

#### **6.7.2.4 Measurements during conditioning**

Monitor the specimen during the conditioning period to detect any alarm or fault signals. During the last 30 min of the conditioning, subject the specimen to the reduced functional test in accordance with 6.1.7.

#### **6.7.2.5 Final measurements**

**6.7.2.5.1** After the recovery period of at least 1 h at standard atmospheric conditions, measure the response point of the specimen in accordance with 6.1.6.

**6.7.2.5.2** Designate the greater of the response points measured in this test and that measured for the same specimen in the reproducibility test as  $D_{\max}$ , and the lesser as  $D_{\min}$ .

### **6.7.3 Requirements**

**6.7.3.1** No alarm or fault signals shall be given during the transition to the conditioning temperature or during the conditioning.

**6.7.3.2** The specimen shall give an alarm signal in response to the reduced function test.

**6.7.3.3** The ratio point values  $D_{\max}$ :  $D_{\min}$  shall be not greater than 1,26.

## ISO 7240-10:2012(E)

### 6.8 Cold (operational)

#### 6.8.1 Object of test

To demonstrate the ability of the specimen to function correctly at low ambient temperatures appropriate to the anticipated service temperature.

#### 6.8.2 Test procedure

##### 6.8.2.1 Reference

Use the test apparatus and perform the procedure as specified in IEC 60068-2-1, Test Ab, and 6.8.2.2 to 6.8.2.4.

##### 6.8.2.2 State of the specimen during conditioning

Mount the specimen as specified in 6.1.3 and connect it to supply and monitoring equipment as specified in 6.1.2.

##### 6.8.2.3 Conditioning

Apply the following conditioning:

- temperature:  $(-10 \pm 3) \text{ }^\circ\text{C}$ ;
- duration: 16 h.

NOTE Test Ab specifies rates of change of temperature of  $\leq 1 \text{ }^\circ\text{C}/\text{min}$  for the transitions to and from the conditioning temperature.

##### 6.8.2.4 Measurements during conditioning

Monitor the specimen during the conditioning period to detect any alarm or fault signals. During the last 30 min of the conditioning, subject the specimen to the reduced functional test in accordance with 6.1.7.

##### 6.8.2.5 Final measurements

**6.8.2.5.1** After the recovery period of at least 1 h at standard atmospheric conditions, measure the response point of the specimen in accordance with 6.1.6.

**6.8.2.5.2** Designate the greater of the response points measured in this test and that measured for the same specimen in the reproducibility test as  $D_{\text{max}}$ , and the lesser as  $D_{\text{min}}$ .

### 6.8.3 Requirements

**6.8.3.1** No alarm or fault signals shall be given during the transition to or the period at the conditioning temperature.

**6.8.3.2** The specimen shall give an alarm signal in response to the reduced functional test.

**6.8.3.3** The ratio  $D_{\text{max}}: D_{\text{min}}$  shall be not greater than 1,26.

### 6.9 Damp heat, cyclic (operational)

#### 6.9.1 Object of test

To demonstrate the ability of the specimen to function in an environment with high relative humidity (RH) where condensation on the equipment can occur.

## 6.9.2 Test procedure

### 6.9.2.1 Reference

Use the test apparatus and procedures as specified in IEC 60068-2-30 using the Variant 1 test cycle and controlled recovery conditions and in 6.9.2.2 to 6.9.2.4.

### 6.9.2.2 State of the specimen during conditioning

Mount the specimen as specified in 6.1.3 and connect it to supply and monitoring equipment as specified in 6.1.2.

Any self-test feature intended to monitor the transmission of the detector window can be disabled during this test.

### 6.9.2.3 Conditioning

The following severity of conditioning shall be applied:

- temperature:  $(40 \pm 2) ^\circ\text{C}$ ;
- number of cycles: 2.

### 6.9.2.4 Measurements during conditioning

6.9.2.4.1 Monitor the specimen during the conditioning period to detect any alarm or fault signals.

6.9.2.4.2 During the last 30 min of the high-temperature phase of the last cycle, subject the specimen to the reduced functional test described in 6.1.7.

### 6.9.2.5 Final measurements

6.9.2.5.1 After the recovery period of at least 1 h at standard atmospheric conditions, measure the response point of the specimen in accordance with 6.1.6.

6.9.2.5.2 Designate the greater of the response points measured in this test and that measured for the same specimen in the reproducibility test as  $D_{\text{max}}$ , and the lesser as  $D_{\text{min}}$ .

## 6.9.3 Requirements

6.9.3.1 No alarm or fault signals shall be given during the transition to or the period at the conditioning temperature.

6.9.3.2 The specimen shall give an alarm signal in response to the reduced functional test.

6.9.3.3 The ratio  $D_{\text{max}}: D_{\text{min}}$  shall be not greater than 1,26.

## 6.10 Damp heat, steady state (endurance)

### 6.10.1 Object of test

To demonstrate the ability of the specimen to withstand the long-term effects of humidity in the service environment (e.g. changes in electrical properties of materials, chemical reactions involving moisture, galvanic corrosion).

## ISO 7240-10:2012(E)

### 6.10.2 Test procedure

#### 6.10.2.1 Reference

Use the test apparatus and perform the procedure as specified in IEC 60068-2-78, Test Cab, and in 6.10.2.2 to 6.10.2.4.

#### 6.10.2.2 State of the specimen during conditioning

Mount the specimen as specified in 6.1.3. Do not supply it with power during the conditioning.

#### 6.10.2.3 Conditioning

Apply the following conditioning:

- temperature:  $(40 \pm 2)$  °C;
- relative humidity:  $(93 \pm 3)$  %;
- duration: 21 d.

#### 6.10.2.4 Final measurements

**6.10.2.4.1** After a recovery period of between 1 h and 2 h in standard atmospheric conditions, measure the response point as specified in 6.1.5.

**6.10.2.4.2** Designate the greater of the response points measured in this test and that measured for the same specimen in the reproducibility test as  $D_{\max}$ , and the lesser as  $D_{\min}$ .

### 6.10.3 Requirements

**6.10.3.1** No fault signal attributable to the endurance conditioning shall be given on reconnection of the specimen.

**6.10.3.2** The ratio  $D_{\max}: D_{\min}$  shall be not greater than 1,26.

## 6.11 Sulfur dioxide (SO<sub>2</sub>) corrosion (endurance)

### 6.11.1 Object of test

To demonstrate the ability of the specimen to withstand the corrosive effects of sulfur dioxide as an atmospheric pollutant.

### 6.11.2 Test procedure

#### 6.11.2.1 Reference

Use the test apparatus and procedure as generally specified in IEC 60068-2-42, Test Kc, but carry out the conditioning as specified in 6.11.2.3.

#### 6.11.2.2 State of the specimen during conditioning

Mount the specimen as specified in 6.1.3. Do not supply it with power during the conditioning, but equip it with untinned copper wires of the appropriate diameter, connected to a sufficient number of terminals to allow the final measurement to be made without making further connections to the specimen.



### 6.11.2.3 Conditioning

Apply the following conditioning:

- temperature:  $(25 \pm 2) ^\circ\text{C}$ ;
- relative humidity:  $(93 \pm 3) \%$ ;
- SO<sub>2</sub> concentration:  $(25 \pm 5) \mu\text{l/l}$ ;
- duration: 21 d.

### 6.11.2.4 Final measurements

**6.11.2.4.1** Immediately after the conditioning, subject the specimen to a drying period of 16 h at  $(40 \pm 2) ^\circ\text{C}$  and  $\leq 50\%$  RH, followed by a recovery period of at least 1 h at the standard atmospheric conditions. After this, measure the response point as specified in 6.1.5.

**6.11.2.4.2** Designate the greater of the response points measured in this test and that measured for the same specimen in the reproducibility test as  $D_{\text{max}}$ , and the lesser as  $D_{\text{min}}$ .

### 6.11.3 Requirements

**6.11.3.1** No fault signal attributable to the endurance conditioning shall be given on reconnection of the specimen.

**6.11.3.2** The ratio  $D_{\text{max}}: D_{\text{min}}$  shall be not greater than 1,26.

## 6.12 Shock (operational)

### 6.12.1 Object of test

To demonstrate the immunity of the specimen to mechanical shocks that are likely to occur, albeit infrequently, in the anticipated service environment.

### 6.12.2 Test procedure and apparatus

#### 6.12.2.1 General

Use the test apparatus and perform the procedure generally as specified in IEC 60068-2-27, Test Ea, but carry out the conditioning as specified in 6.12.2.3.

#### 6.12.2.2 State of the specimen during conditioning

Mount the specimen as specified in 6.1.3 to a rigid fixture and connect it to its supply and monitoring equipment as specified in 6.1.2.

#### 6.12.2.3 Conditioning

**6.12.2.3.1** For specimens with a mass  $\leq 4,75$  kg, apply the following conditioning:

- shock pulse type: half sine;
- pulse duration: 6 ms;
- peak acceleration:  $10(100 - 20M) \text{ m/s}^2$  (where  $M$  is the mass of the specimen in kilograms);

## ISO 7240-10:2012(E)

- number of directions: 6;
- pulses per direction: 3.

**6.12.2.3.2** Do not test specimens with a mass >4,75 kg.

### 6.12.2.4 Measurements during conditioning

Monitor the specimen during the conditioning period and for a further 2 min to detect any alarm or fault signals.

### 6.12.2.5 Final measurements

**6.12.2.5.1** After the conditioning, measure the response point as specified in 6.1.5.

**6.12.2.5.2** Designate the greater of the response points measured in this test and that measured for the same specimen in the reproducibility test as  $D_{\max}$ , and the lesser as  $D_{\min}$ .

### 6.12.3 Requirements

**6.12.3.1** No alarm or fault signals shall be given during the conditioning period or the additional 2 min.

**6.12.3.2** The ratio  $D_{\max}: D_{\min}$  shall be not greater than 1,26.

## 6.13 Impact (operational)

### 6.13.1 Object of test

To demonstrate the immunity of the specimen to mechanical impacts upon its surface, which it may sustain in the normal service environment, and which it can reasonably be expected to withstand.

### 6.13.2 Test procedure

#### 6.13.2.1 Apparatus

Use the test apparatus specified in Annex E.

#### 6.13.2.2 State of the specimen during conditioning

Mount the specimen rigidly to the apparatus by its normal mounting means and position it so that it is struck by the upper half of the impact face when the hammer is in the vertical position (i.e. when the hammerhead is moving horizontally). Choose the azimuthal direction and the position of impact relative to the specimen as that most likely to impair the normal functioning of the specimen. Connect the specimen to its supply and monitoring equipment as specified in 6.1.2.

#### 6.13.2.3 Conditioning

Use the following test parameters during the conditioning:

- impact energy:  $(1,9 \pm 0,1)$  J;
- hammer velocity:  $(1,5 \pm 0,13)$  m/s;
- number of impacts: 1.

#### 6.13.2.4 Measurements during conditioning

Monitor the specimen during the conditioning period and for a further 2 min to detect any alarm or fault signals.

#### 6.13.2.5 Final measurements

6.13.2.3.1 After the conditioning, measure the response point as specified in 6.1.5.

6.13.2.3.2 Designate the greater of the response points measured in this test and that measured for the same specimen in the reproducibility test as  $D_{\max}$ , and the lesser as  $D_{\min}$ .

#### 6.13.3 Requirements

6.13.3.1 No alarm or fault signals shall be given during the conditioning period or the additional 2 min.

6.13.3.2 The impact shall not detach the flame detector from its base or the base from the mounting.

6.13.3.3 The ratio of the response points  $D_{\max}: D_{\min}$  shall not be greater than 1,26.

### 6.14 Vibration, sinusoidal (operational)

#### 6.14.1 Object of test

To demonstrate the immunity of the specimen to vibration at levels considered appropriate to the normal service environment.

#### 6.14.2 Test procedure

##### 6.14.2.1 Reference

Use the test apparatus and perform the procedure as specified in IEC 60068-2-6, Test Fc, and in 6.14.2.2 to 6.14.2.5.

##### 6.14.2.2 State of the specimen during conditioning

Mount the specimen on a rigid fixture as specified in 6.1.3 and connect it to its supply and monitoring equipment as specified in 6.1.2. Apply the vibration in each of three mutually perpendicular axes in turn, and so that one of the three axes is perpendicular to the normal mounting plane of the specimen.

##### 6.14.2.3 Conditioning

6.14.2.3.1 Apply the following conditioning:

- frequency range: (2 to 10) Hz;
- displacement: 1,24 mm;
- frequency range: (10 to 150) Hz;
- acceleration amplitude:  $5 \text{ m/s}^2$  ( $\approx 0,5 g_n$ );
- number of axes: 3;
- sweep rate: 1 octave/min;
- number of sweep cycles: 1 /axis.

## ISO 7240-10:2012(E)

**6.14.2.3.2** The vibration operational and endurance tests may be combined such that the specimen is subjected to the operational test conditioning followed by the endurance test conditioning in one axis before changing to the next axis. It is necessary to make only one final measurement.

### 6.14.2.4 Measurements during conditioning

Monitor the specimen during the conditioning period to detect any alarm or fault signals.

### 6.14.2.5 Final measurements

**6.14.2.5.1** After the conditioning, visually inspect the specimen for mechanical damage both internally and externally. Then measure the response point as specified in 6.1.5.

NOTE The final measurements are normally made after the vibration endurance test and it is necessary to make them here only if the operational test is conducted in isolation.

**6.14.2.5.2** Designate the greater of the response points measured in this test and that measured for the same specimen in the reproducibility test as  $D_{\max}$ , and the lesser as  $D_{\min}$ .

### 6.14.3 Requirements

**6.14.3.1** No alarm or fault signals shall be given during the conditioning. No mechanical damage neither internally nor externally shall result.

**6.14.3.2** The ratio of the response points  $D_{\max}: D_{\min}$  shall not be greater than 1,26.

## 6.15 Vibration, sinusoidal (endurance)

### 6.15.1 Object of test

To demonstrate the ability of the specimen to withstand the long-term effects of vibration at levels appropriate to the shipping, installation and service environment.

### 6.15.2 Test procedure

#### 6.15.2.1 Reference

Use the test apparatus and perform the procedure as specified in IEC 60068-2-6, Test Fc, and in 6.15.2.2 to 6.15.2.4.

#### 6.15.2.2 State of the specimen during conditioning

Mount the specimen on a rigid fixture as specified in 6.1.3, but do not supply it with power during conditioning. Apply the vibration in each of three mutually perpendicular axes in turn and so that one of the three axes is perpendicular to the normal mounting axis of the specimen.

#### 6.15.2.3 Conditioning

Apply the following conditioning:

- frequency range: (10 to 150) Hz;
- acceleration amplitude: 10 m/s<sup>2</sup> ( $\approx 1,0 g_n$ );
- number of axes: 3;

- sweep rate: 1 octave/min;
- number of sweep cycles: 20 /axis.

NOTE The vibration operational and endurance tests can be combined such that the specimen is subjected to the operational test conditioning followed by the endurance-test conditioning in one axis before changing to the next axis. It is only necessary to make one final measurement.

#### 6.15.2.4 Final measurements

6.15.2.4.1 After the conditioning, measure the response point of the specimen as specified in 6.1.6.

6.15.2.4.2 Designate the greater of the response points measured in this test and that measured for the same specimen in the reproducibility test as  $D_{max}$ , and the lesser as  $D_{min}$ .

#### 6.15.3 Requirements

The ratio of the response points  $D_{max}: D_{min}$  shall not be greater than 1,26.

### 6.16 Variation of supply parameters (operational)

#### 6.16.1 Object of test

To show that, within the specified range(s) of the supply parameters (e.g. voltage), the response point of the detector is not unduly dependent on those parameters.

#### 6.16.2 Test procedure

6.16.2.1 Measure the response point of the specimen as specified in 6.1.5, at the upper and lower limits of the supply parameter (e.g. voltage) range(s) specified by the manufacturer.

NOTE For non-addressable (conventional) detectors, the supply parameter is the d.c. voltage applied to the detector. For other types of detector (e.g. analogue addressable), it can be necessary to consider signal levels and timing.

6.16.2.2 Designate the greater of the response points measured in this test and that measured for the same specimen in the reproducibility test as  $D_{max}$ , and the lesser as  $D_{min}$ .

#### 6.16.3 Requirements

The ratio  $D_{max}: D_{min}$  shall be not greater than 1,26.

### 6.17 EMC immunity tests (operational)

6.17.1 The following EMC immunity tests shall be carried out as specified in EN 50130-4:

a) electrostatic discharge;

NOTE For UV detectors that respond to the radiation from the spark, the time between discharges can be increased up to a maximum of 30 s.

b) radiated electromagnetic fields;

c) conducted disturbances induced by electromagnetic fields;

d) fast transient bursts;

e) slow high-energy voltage surges.

## ISO 7240-10:2012(E)

**6.17.2** For these tests, the criteria for compliance as specified in EN 50130-4 and the following shall apply.

- a) The functional test, called for in the initial and final measurements, shall be as follows.
  - Measure the response points as specified in 6.1.5.
  - Designate the greater of the response point measured in this test and that measured for the same specimen in the reproducibility test  $D_{\max}$ , and the lesser as  $D_{\min}$ .
- b) The required operating condition shall be as specified in 6.1.2.
- c) The specimen shall be mounted in accordance with 6.1.3.
- d) The acceptance criteria for the functional test after the conditioning shall be that the ratio  $D_{\max} : D_{\min}$  shall be not greater than 1,26.

## 6.18 IP — Optional function

### 6.18.1 Object of test

To demonstrate that the degree of protection provided by the enclosure of the specimen, with regard to the ingress of solid foreign objects and the harmful effects due to the ingress of water.

### 6.18.2 Enclosure of the flame detector

The enclosure of the flame detector shall be taken as comprising any parts of the outer physical envelope of the specimen which prevents or restricts access of solid foreign objects to the sensor(s), electronic assembly(ies) and wiring terminals.

Ingress of liquid inside the enclosure is possible, but should not adversely affect the operation of the specimen.

### 6.18.3 Test procedure

#### 6.18.3.1 Reference

The test apparatus and test procedure shall be as described in IEC 60529 and in 6.18.3.2 to 6.18.3.4.

#### 6.18.3.2 State of the specimen during conditioning

**6.18.3.2.1** Mount the specimen, including wiring termination boxes which form part of the flame detector, as specified in 6.1.3 to a rigid fixture, and in accordance with IEC 60529.

**6.18.3.2.2** For the test for protection against ingress of water, connect it to its supply and monitoring equipment as specified in 6.1.2.

**6.18.3.2.3** For the test for protection against ingress of solid foreign objects and the test for protection against access to hazardous parts, do not connect it to its supply and monitoring equipment.

#### 6.18.3.3 Conditioning

Apply the test conditions specified in IEC 60529 for the following IP Codes:

- a) type A: no test;
- b) type B: IP54C
  - 1) protection against solid foreign objects (indicated by the first characteristic numeral);
  - 2) protection against water (indicated by the second characteristic numeral);

- 3) protection against access to hazardous parts (indicated by the additional letter).

#### 6.18.3.4 Measurement during conditioning

Monitor the specimen during the conditioning period to detect any alarm or fault signals.

#### 6.18.3.5 Final measurements

6.18.3.5.1 After conditioning perform the following.

- a) Examine the specimen for ingress of water.
- b) Measure the response point as specified in 6.1.5.

6.18.3.5.2 Designate the greater of the response points measured in this test and that measured for the same specimen in the reproducibility test as  $D_{max}$ , and the lesser as  $D_{min}$ .

#### 6.18.4 Requirements

6.18.4.1 For type B, the following requirements shall be satisfied.

- a) No alarm or fault signals shall be given during the conditioning period.
- b) The specimen shall comply with rating IP54C specified in IEC 60529.
- c) No water shall have penetrated the enclosure or if water has penetrated the enclosure, the specimen shall have incorporated adequate provision for drainage.

6.18.4.2 The ratio of the response points  $D_{max}: D_{min}$  shall not be greater than 1,26.

### 7 Test report

The test report shall contain as a minimum the following information:

- a) identification of the flame detector tested;
- b) reference to this part of ISO 7240, i.e. ISO 7240-10:2012;
- c) results of the test: the individual response points and the minimum, maximum and arithmetic mean values where appropriate;
- d) detector classification;
- e) IP rating (if type B);
- f) conditioning period and the conditioning atmosphere;
- g) temperature and the relative humidity in the test room throughout the test;
- h) details of the supply and monitoring equipment and the alarm criteria;
- i) details of any deviation from this part of ISO 7240 or from the International Standards to which reference is made;
- j) details of any operations regarded as optional.

## Annex A (normative)

### Apparatus for response point determination

#### A.1 Optical bench

**A.1.1** The apparatus uses an optical bench to allow the distance between the source and the detector to be adjusted while maintaining the relative alignment of the optical axes of the source and the detector. In order to allow for variations in response point, the bench shall have an effective working length of at least 2,5 m.

**A.1.2** The mounting stands used for the specimen and for other parts of the test equipment shall be constrained to move in a direction parallel to the axis of the bench. Means shall be provided to measure the distances between the individual bench-mounted items to an accuracy of  $\pm 10$  mm.

**A.1.3** The detector mounting stand shall allow adjustment of the height and orientation of the detector such that its optical axis can be made coincident with the source optical axis. The detector mounting stand shall also allow the detector to be rotated about its optical axis and, independently, about a second axis perpendicular to the optical axis, and passing through the point of intersection of the optical axis and the plane of the detector sensing element(s). Means shall be provided to measure the angular rotations with an accuracy of  $\pm 5^\circ$ .

**A.1.4** An example of a suitable optical bench arrangement is shown in Figure A.1.

#### A.2 Radiation source

**A.2.1** The radiation shall be produced by a gas burner, burning methane of not less than 98 % purity, whose flame gives a stable (flicker-free) radiation output in the wavelength band in which the detector under test is intended to operate. The flicker in these bands shall be measured using an appropriate method. The root mean square (RMS) amplitude modulation of the radiation shall not exceed 5 %.

**A.2.2** The effective radiation output shall be set by an aperture placed in front of the flame in such a position that the complete area of the aperture is filled by the flame when viewed from any allowable position of the detector under test. For the purposes of this test method, the aperture shall be considered as the source of radiation. The perpendicular axis through the centre of the aperture shall be considered to be the optical axis of the source.

**A.2.3** A gas burner suitable for use as a source is described in Annex F.

#### A.3 Shutter

A shutter shall be provided such that the specimen can be shielded from the radiation source. The shutter shall allow the duration of the exposure of the detector to the source to be controlled with an accuracy of  $\pm 2$  s.

#### A.4 Modulator

The radiation from the source shall be modulated by suitable means (e.g. a rotating chopper disc) to provide the form of modulation specified by the manufacturer for the detector under test. The modulation frequency specified may be zero. If the manufacturer does not specify the modulation, then measurements shall be carried out on a specimen chosen at random to determine the frequency corresponding to the peak of the detector's response. This frequency shall be noted and used for all subsequent measurements.



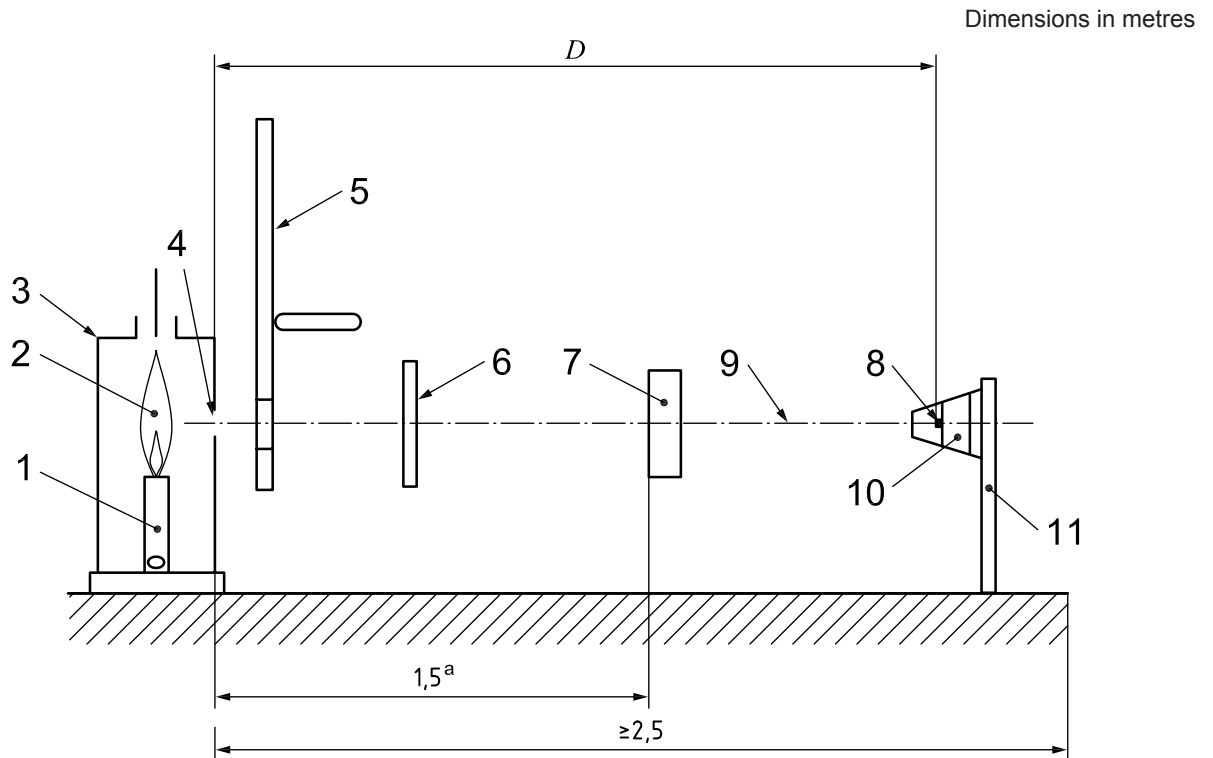

**Key**

- 1 methane gas burner
- 2 flame
- 3 burner housing
- 4 aperture
- 5 modulator (chopper disc)
- 6 shutter
- 7 radiometer
- 8 sensing element(s)
- 9 optical axis
- 10 detector
- 11 stand for detector
- $D$  response point
- <sup>a</sup> Reference.

**Figure A.1 — Optical bench arrangement**

## A.5 Radiometer

**A.5.1** A radiometer shall be provided to monitor the irradiance produced by the source. The sensitive element of the radiometer shall be positioned at a point on the source optical axis at a distance in the range 1 400 mm to 1 600 mm from the aperture. The radiometer shall be fitted on a stand on the optical bench such that the distance from the aperture can be set within the specified range with a repeatability of  $\pm 5$  mm.

**A.5.2** The wavelength response of the radiometer shall be appropriate to the detector under test and may be specified by the manufacturer. If the manufacturer does not specify a wavelength range, then the radiometer shall respond only to radiation in the range  $4,0 \mu\text{m}$  to  $4,8 \mu\text{m}$  for infrared (IR) detectors and 160 nm to 280 nm for ultra-violet (UV) detectors.

## Annex B (normative)

### Liquid (heptane) fire (TF5)

#### B.1 Fuel

Approximately 650 g of a mixture of *n*-heptane (purity  $\geq 99\%$ ) with approximately 3 % of toluene (purity  $\geq 99\%$ ), by volume. The precise quantities may be varied to obtain valid tests.

#### B.2 Arrangement

**B.2.1** The heptane/toluene mixture shall be burnt in a square tray made from 2 mm thick sheet steel with dimensions of approximately 33 cm  $\times$  33 cm  $\times$  5 cm.

**B.2.2** The tray may be placed within a larger tray filled with water to prevent burning fuel from spraying outside the fuel tray.

#### B.3 Ignition

Ignition shall be by flame or spark.

#### B.4 End-of-test condition

30 s after exposure of detectors to the fire.

## **Annex C** (normative)

### **Liquid (methylated spirit) fire (TF6)**

#### **C.1 Fuel**

Methylated spirit, at least 90 % ethanol  $C_2H_5OH$ , to which has been added 10 % of a denaturant impurity (methanol).

#### **C.2 Arrangement**

The methylated spirit shall be burnt in a container made from 2 mm thick sheet steel , with a base surface area of 1 900 cm<sup>2</sup>, with dimensions of approximately 43,5 cm × 43,5 cm × 5 cm high.

#### **C.3 Volume**

Approximately 1,5 l of methylated spirit shall be used.

#### **C.4 Ignition**

Ignition shall be by flame or spark.

#### **C.5 End-of-test condition**

30 s after exposure of detectors to the fire.

## Annex D (normative)

### Apparatus for dazzling test

**D.1** The dazzling test apparatus (see Figure D.1) shall be constructed so that it can be installed on the optical bench shown in Figure A.1 without impeding the determination of response points.

**D.2** The light source shall consist of two identical 25 W tungsten incandescent lamps having clear glass envelopes and conforming to IEC 60064. The light source shall be supplied with either 50 Hz a.c. or 60 Hz a.c.

**D.3** The light source shall be mounted so that the direct line of sight from the detector sensor to the radiation source on the apparatus shown in Figure D.1 is maintained. The light source and the detector sensor shall be connected in such a way that the distance between the lamp stand and the detector is approximately 500 mm and is maintained at this fixed distance when the detector stand is moved.

**D.4** The voltage supply shall be adjusted so that the colour temperature of the lamps is  $2\,850\text{ K} \pm 100\text{ K}$ . The distance between the lamps and the detector shall then be adjusted so that the lamps provide a luminance in the plane of the detector sensor(s) of 100 lx.

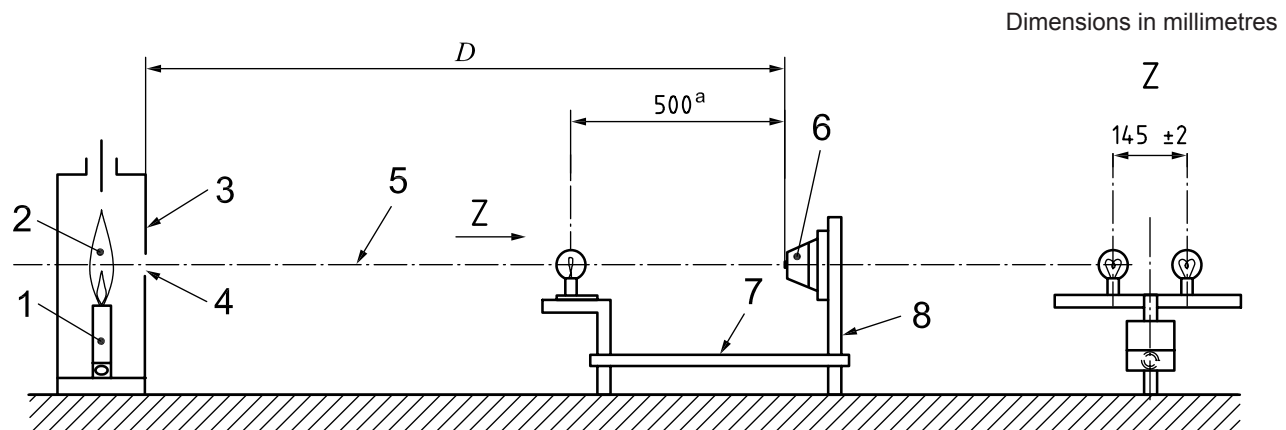

#### Key

- 1 methane burner
- 2 flame
- 3 burner housing
- 4 aperture
- 5 optical axis
- 6 detector
- 7 stand for lamps
- 8 stand for detectors
- D* response point
- <sup>a</sup> Reference.

Figure D.1 — Apparatus for dazzling test

## Annex E (normative)

### Apparatus for impact test

**E.1** The apparatus (see Figure E.1) consists essentially of a swinging hammer comprising a rectangular section head (striker) with a chamfered impact face, mounted on a tubular steel shaft. The hammer is fixed into a steel boss, which runs on ball bearings on a fixed steel shaft mounted in a rigid steel frame, so that the hammer can rotate freely about the axis of the fixed shaft. The design of the rigid frame is such as to allow complete rotation of the hammer assembly when the specimen is not present.

**E.2** The striker, with overall dimensions of 76 mm (width) × 50 mm (height) × 94 mm (length), is manufactured from aluminium alloy, Al Cu<sub>4</sub> Si Mg, as specified in ISO 209, which has been solution- and precipitation-treated. It has a plane-impact face chamfered at  $(60 \pm 1)^\circ$  to the long axis of the head. The tubular steel shaft has an outside diameter of  $(25 \pm 0,1)$  mm with a wall thickness of  $(1,6 \pm 0,1)$  mm.

**E.3** The striker is mounted on the shaft so that its long axis is at a radial distance of 305 mm from the axis of rotation of the assembly, the two axes being mutually perpendicular. The central boss is 102 mm in outside diameter and 200 mm long, and is mounted coaxially on the fixed steel pivot shaft, which is approximately 25 mm in diameter; however, the precise diameter of the shaft depends on the bearings used.

**E.4** Diametrically opposite the hammer shaft are two steel counter-balance arms, each 20 mm in outside diameter and 185 mm long. These arms are screwed into the boss so that the length of 150 mm protrudes. A steel counter-balance weight is mounted on the arms so that its position can be adjusted to balance the weight of the striker and arms, as in Figure E.1. On the end of the central boss is mounted a 150 mm-diameter aluminium alloy pulley, 12 mm wide, and around this is wound an inextensible cable, with one end fixed to the pulley. The other end of the cable supports the operating weight.

**E.5** The rigid frame also supports the mounting board on which the specimen is mounted by its normal fixings. The mounting board is adjustable vertically so that the upper half of the impact face of the hammer shall strike the specimen when the hammer is moving horizontally, as shown in Figure E.1.

**E.6** To operate the apparatus, the position of the mounting board with the specimen is first adjusted as shown in Figure E.1 and the mounting board is then secured rigidly to the frame. The hammer assembly is then balanced carefully by adjustment of the counter-balance weight with the operating weight removed. The hammer arm is then drawn back to the horizontal position ready for release and the operating weight is reinstated. On release of the assembly, the operating weight shall spin the hammer and arm through an angle of  $3\pi/2$  rad to strike the specimen. The mass, in kilograms, of the operating weight to produce the required impact energy of 1,9 J equals:

$$\frac{0,388}{3\pi r} \text{ kg}$$

where  $r$  is the effective radius of the pulley, in metres. This equals approximately 0,55 kg for a pulley radius of 75 mm.

**E.7** As this part of ISO 7240 requires a hammer velocity at impact of  $(1,5 \pm 0,13)$  m/s, the mass of the hammer head shall need to be reduced by drilling the back face sufficiently to obtain this velocity. It is estimated that a head of mass of about 0,79 kg is required to obtain the specified velocity, but this shall be determined by trial and error.

ISO 7240-10:2012(E)

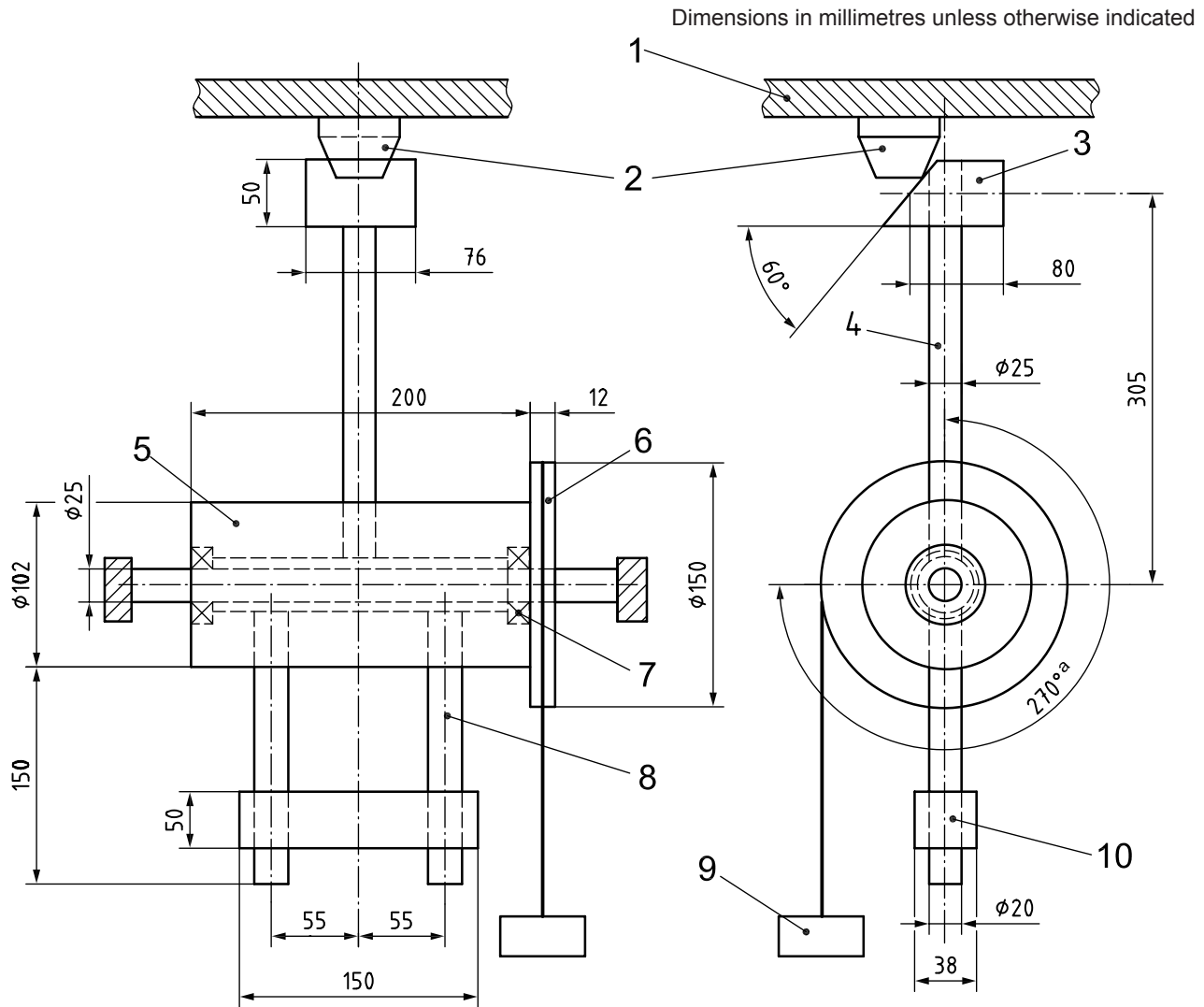

**Key**

- 1 mounting board
- 2 detector
- 3 striker
- 4 striker shaft
- 5 boss
- 6 pulley
- 7 ball bearings
- 8 counter-balance arms
- 9 operating weight
- 10 counter-balance weight

a Angle of movement.

NOTE The dimensions shown are for guidance, apart from those relating to the hammer head.

**Figure E.1 — Apparatus for impact test**

## **Annex F** (informative)

### **Example of methane burner**

Figure F.1 shows an example of a burner (Meker burner) which is suitable for the source in Clause A.2. The burner should be supplied with gas at a constant pressure to maintain constant radiated output.

ISO 7240-10:2012(E)

Dimensions in millimetres

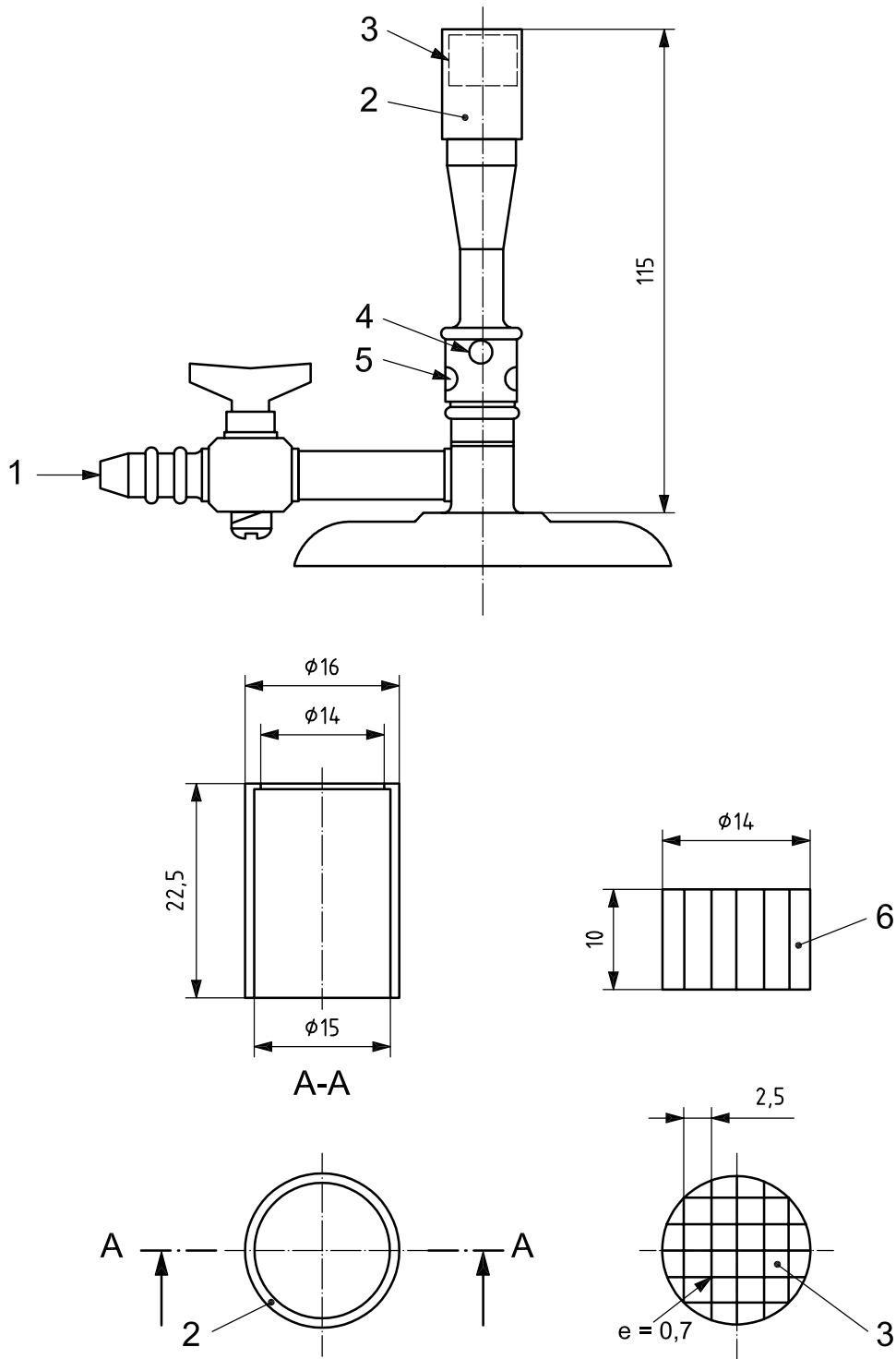

**Key**

- 1 gas
- 2 piece A
- 3 piece B
- 4 4 holes
- 5 4 holes
- 6 grid

**Figure F.1 — Example of methane burner**





## **ISO 7240-10:2012(E)**

---

---

### **ICS 13.220.20**

Price based on 34 pages