Fire detection and alarm systems —
Part 1:
General and definitions

Systemes de detection et d'alarme d'incendie —
Partie 1: Généralités et définitions





COPYRIGHT PROTECTED DOCUMENT

© ISO 2014

All rights reserved. Unless otherwise specified, no part of this publication may be reproduced or utilized otherwise in any form or by any means, electronic or mechanical, including photocopying, or posting on the internet or an intranet, without prior written permission. Permission can be requested from either ISO at the address below or ISO's member body in the country of the requester.

ISO copyright office
Case postale 56 • CH-1211 Geneva 20
Tel. + 41 22 749 01 11
Fax + 41 22 749 09 47
E-mail copyright@iso.org
Web www.iso.org

Published in Switzerland

Contents

Page

Foreword	iv
Introduction	vi
1 Scope	1
2 Terms and definitions and abbreviated terms	1
2.1 Definitions.....	1
2.2 Abbreviated terms	15
3 Functions	15

Foreword

ISO (the International Organization for Standardization) is a worldwide federation of national standards bodies (ISO member bodies). The work of preparing International Standards is normally carried out through ISO technical committees. Each member body interested in a subject for which a technical committee has been established has the right to be represented on that committee. International organizations, governmental and non-governmental, in liaison with ISO, also take part in the work. ISO collaborates closely with the International Electrotechnical Commission (IEC) on all matters of electrotechnical standardization.

The procedures used to develop this document and those intended for its further maintenance are described in the ISO/IEC Directives, Part 1. In particular the different approval criteria needed for the different types of ISO documents should be noted. This document was drafted in accordance with the editorial rules of the ISO/IEC Directives, Part 2 (see www.iso.org/directives).

Attention is drawn to the possibility that some of the elements of this document may be the subject of patent rights. ISO shall not be held responsible for identifying any or all such patent rights. Details of any patent rights identified during the development of the document will be in the Introduction and/or on the ISO list of patent declarations received (see www.iso.org/patents).

Any trade name used in this document is information given for the convenience of users and does not constitute an endorsement.

For an explanation on the meaning of ISO specific terms and expressions related to conformity assessment, as well as information about ISO's adherence to the WTO principles in the Technical Barriers to Trade (TBT) see the following URL: Foreword - Supplementary information

The committee responsible for this document is ISO/TC 21, *Equipment for fire protection and firefighting*, Subcommittee SC 3, *Fire detection and alarm systems*.

This third edition cancels and replaces the second edition (ISO 7240-1:2005), which has been technically revised.

ISO 7240 consists of the following parts, under the general title *Fire detection and alarm systems*:

- *Part 1: General and definitions*
- *Part 2: Control and indicating equipment*
- *Part 3: Audible alarm devices*
- *Part 4: Power supply equipment*
- *Part 5: Point-type heat detectors*
- *Part 6: Carbon monoxide fire detectors using electro-chemical cells*
- *Part 7: Point-type smoke detectors using scattered light, transmitted light or ionization*
- *Part 8: Carbon monoxide fire detectors using an electro-chemical cell in combination with a heat sensor*
- *Part 9: Test fires for fire detectors [Technical Specification]*
- *Part 10: Point-type flame detectors*
- *Part 11: Manual call points*
- *Part 12: Line type smoke detectors using a transmitted optical beam*
- *Part 13: Compatibility assessment of system components*

- *Part 14: Design, installation, commissioning and service of fire detection and fire alarm systems in and around buildings*
- *Part 15: Point type fire detectors using scattered light, transmitted light or ionization sensors in combination with a heat sensor*
- *Part 16: Sound system control and indicating equipment*
- *Part 17: Short-circuit-isolators*
- *Part 18: Input/output devices*
- *Part 19: Design, installation, commissioning and service of sound systems for emergency purposes*
- *Part 20: Aspirating smoke detectors*
- *Part 21: Routing equipment*
- *Part 22: Smoke-detection equipment for ducts*
- *Part 23: Visual alarm devices*
- *Part 24: Sound system loudspeakers*
- *Part 25: Components using radio transmission paths*
- *Part 27: Point-type fire detectors using a scattered-light, transmitted-light or ionization smoke sensor, an electrochemical-cell carbon-monoxide sensor and a heat sensor*
- *Part 28: Fire protection control equipment*

The following parts are in preparation

- *Part 29: Video fire detectors*

Introduction

ISO 7240 (all parts) specifies components of fire detection and alarm systems, requirements for their interconnection and installation and the performance, testing, and servicing of parts or of complete systems. It provides

- local and/or remote signals to organizations having authority to respond to fire alarms, and
- signals to initiate the operation of fire protection equipment and other systems.

A fire detection and alarm system may be activated by automatic detection devices or by manual operation and should fulfil its functions without errors or omissions, including

- detecting quickly enough to fulfil its intended function,
- reliably transmitting the detection signal to the control and indicating equipment and, if applicable, the fire alarm receiving station,
- translating the detection signal into a clear alarm signal that will attract the attention of occupants in an immediate and unmistakable way,
- remaining insensitive to phenomena other than those which its function is to detect, and
- signalling immediately and clearly any supervised fault that might jeopardize the correct performance of the fire detection and alarm system.

A fire detection and alarm system should not

- be adversely affected by any other systems whether associated with it, or not
- be rendered partially or totally inoperative by the fire or the phenomenon which it is designed to detect before the fire or phenomenon has been detected.

ISO 7240 (all parts) applies to fire detection and alarm systems installed in and around buildings. It can be used as a basis for the assessment of systems for other purposes, e.g. mines, ships, but the specific nature of each application should be considered before use. Additional performance and environmental tests may be necessary. It does not preclude the manufacture or use of systems having special characteristics suitable for protection of specific risks against specific hazards.

A fire detection and alarm system is required to function satisfactorily not only in the event of fire, but also during and after exposure to conditions likely to be met in practice such as corrosion, vibration, direct impact, indirect shock, and electromagnetic interference. Some tests specified are intended to assess the performance of system components under such conditions.

The performance of components of fire detection and alarm systems is assessed from the results obtained in the specific tests. The compliance of a component with the relevant part of ISO 7240 does not necessarily ensure that the component will function correctly when connected with another component also conforming to the relevant part of ISO 7240 (e.g. a fire detector with fire detection control and indicating equipment), unless both components have been assessed together as conforming to the requirements for a fire detection and alarm system. Requirements for the assessment of the compatibility of system components are specified in ISO 7240-13. Satisfactory operation of an installed system should be confirmed by testing after completion of the installation (see ISO 7240-14). ISO 7240 (all parts) is not intended to place any other restrictions on the design and construction of such components.

If appropriate, ISO 7240 (all parts) can be applied to the detection part of extinguishing systems, excluding sprinkler heads, although the sensitivity requirements might not be applicable in every instance.

As this revision of this part of ISO 7240 includes terms and definitions collated from other parts of ISO 7240, there may now be some duplication and minor variances which will be corrected in future revisions of the other parts of ISO 7240.

Fire detection and alarm systems —

Part 1: General and definitions

1 Scope

This part of ISO 7240 provides a set of general guidelines and definitions used in describing the fire detection and alarm system (FDAS) equipment installed in and around buildings, and the tests and requirements for these equipments in the other parts of ISO 7240.

ISO 7240 does not apply to smoke alarms, the requirements for which are specified in ISO 12239.

2 Terms and definitions and abbreviated terms

For the purposes of this document, the following terms and definitions and abbreviated terms apply.

2.1 Definitions

2.1.1

A-weighted sound pressure level

twenty times the logarithm to base ten of the ratio of the root-mean-square A-weighted sound pressure to the reference pressure of 20 μPa at 1 kHz, expressed in decibels

Note 1 to entry: The A-weighting characteristics are given in IEC 61672-1.

2.1.2

absorbance index

cf. *m* ([2.1.83](#))

2.1.3

access level

one of several states of equipment in which selected

- controls can be operated,
- manual operations can be carried out,
- indications are visible, and/or
- information can be obtained

2.1.4

addressable point

point which can be individually identified at the control and indicating equipment (see [Figure 1](#), items B and M)

Note 1 to entry: Compare *point* ([2.1.101](#)).

2.1.5

aerosol density

smoke density

amount of particulates per volume as described operationally by one of two parameters:

- m (2.1.83), an absorbance index, used in the testing of smoke detectors using scattered or transmitted light;
- y (2.1.141), a dimensionless variable, used in the testing of smoke detectors using ionization

Note 1 to entry: These parameters are not concentrations *sensu stricto*, but represent values which are proportional to the concentration and have been shown to function in lieu of a true concentration value for the purposes of tests.

**2.1.6
alarm**

signal, or condition, warning of an emergency

**2.1.7
alarm indication**

indication (at the indicating equipment, see [Figure 1](#), items B and M) to show that a detection signal has been received

**2.1.8
alert signal**

audible signal complying with ISO 7731 or visual signal or a combination of audible and visual signals that call attention to the possibility of a hazardous or dangerous situation

**2.1.9
alphanumeric display**

indicator capable of giving information by the display of messages consisting of text and/or numeric characters

**2.1.10
analogue detector**

detector which gives an output signal representing the value of the sensed phenomenon

Note 1 to entry: This may be a true analogue signal or a digitally encoded equivalent of the sensed value.

**2.1.11
ancillary equipment**

equipment which supports fire detection and fire alarm functions not currently defined in ISO 7240

Note 1 to entry: See [Figure 1](#), item N.

**2.1.12
ancillary function**

action performed by equipment not related to fire detection or fire alarm system

Note 1 to entry: See [Figure 1](#), item O.

**2.1.13
aspirating smoke detector**

smoke detector, in which air and aerosols are drawn through a sampling device and carried to one or more smoke-sensing elements by an integral aspirator (e.g. fan or pump)

Note 1 to entry: Each smoke sensing element may contain more than one sensor exposed to the same smoke sample.

**2.1.14
audible alarm device**

AAD

component intended to signal an audible warning of fire to the occupants of a building

Note 1 to entry: AADs are sometimes referred to as “fire alarm sounders”.

2.1.15**cabinet**

housing that affords a degree of protection and robustness to its constituent parts and subassemblies

2.1.16**certification**

third party attestation related to products, processes, systems, or persons

[SOURCE: ISO 1700:2004, 5.5]

2.1.17**combination detector**

detector combining two or more detecting principles in a single housing

2.1.18**combustion gas detector**

fire detector sensitive to gaseous products of combustion and/or thermal decomposition

EXAMPLE Carbon monoxide gas fire detector.

2.1.19**commissioning**

process that verifies the installed equipment or system meets the defined requirements

2.1.20**compatibility**

ability of a component of a FDAS to operate with another component of the same FDAS

2.1.21**competent person**

person who, in relation to the work undertaken, has the necessary knowledge, skill, and experience to complete the work satisfactorily and without danger or injury to any person

2.1.22**component**

device contained in one housing performing at least one or part of a function of a FDAS

EXAMPLE Fire detectors, alarm devices, and control and indicating equipment are components of a FDAS.

Note 1 to entry: Where a function is distributed in separate cabinets, each cabinet is considered as a separate component.

2.1.23**configuration**

arrangement of components of a FDAS specified by number, type, and topology, together with any necessary limits on the transmission paths

2.1.24**confirmation signal**

signal from a fire detector or manual call point which terminates a first alarm state

2.1.25**control and indicating equipment**

cf. *fire alarm control and indicating equipment* ([2.1.46](#)) and *fire detection control and indicating equipment* ([2.1.56](#))

2.1.26**detachable detector**

detector which is designed for removal of the head from its base

2.1.27

detection circuit

transmission path which connects points to the FDCIE

Note 1 to entry: See [Figure 1](#), item B.

Note 2 to entry: Compare *point* ([2.1.101](#)) and *transmission path* ([2.1.130](#)).

2.1.28

detection concept

description of the design of the FDAS with a justification of the choice of detectors, its sensitivity and its spacing; description of the alarm organization, i.e. all measures to be taken in case of an alarm

2.1.29

detection signal

signal from a detection device (see [Figure 1](#), item A) to show that a fire has been detected

2.1.30

detector response

defined change of the status of a fire detector after actuation of an alarm signal

2.1.31

differential detector

detector which initiates an alarm when the difference (normally small) in the magnitudes of the measured phenomenon at two or more places exceeds a certain value for a specified time

2.1.32

documentation

drawings and instructions necessary to understand and to operate the FDAS

2.1.33

earth fault

unwanted connection between earth potential and any part of the control and indicating equipment (see [Figure 1](#), items B and M), transmission paths to the control and indicating equipment, or transmission paths between parts of the control and indicating equipment

2.1.34

emergency

imminent risk or serious threat to persons or property

2.1.35

emergency detection system

application intended for the protection of life, property, or the environment such as

- FDAS,
- gas detection system,
- intrusion and hold-up alarm,
- closed circuit television,
- access control, and
- manual call point

2.1.36**emergency management plan**

documented procedure that considers all aspects of the management of an emergency to ensure the safety of building occupants

Note 1 to entry: The emergency management plan is likely to include the evacuation of building occupants, but under certain circumstances, the retention of occupants in their current locations can be preferable.

2.1.37**evacuation plan**

part of the emergency management plan dealing with the safe and orderly evacuation of building occupants

2.1.38**evacuate signal**

audible or visual signal or a combination of audible and visual signals complying with ISO 8201 that means “evacuate the building immediately”

2.1.39**fault warning routing equipment**

equipment which routes a fault warning signal to a fault warning receiving station

Note 1 to entry: See [Figure 1](#), item J.

2.1.40**fault warning receiving station**

centre from which the necessary corrective measures can be initiated on receipt of a fault signal

Note 1 to entry: See [Figure 1](#), item K.

2.1.41**field**

subdivision of a window

Note 1 to entry: See *fault warning receiving station* ([2.1.40](#)).

2.1.42**final voltage**

lowest recommended voltage to which a battery should be discharged

Note 1 to entry: The final voltage is specified by the battery manufacturer.

2.1.43**fire alarm and fault warning transmission system**

system used for routing fire alarm and fault warning signals from FDAS to fire alarm and fault warning receiving stations

2.1.44**fire alarm circuit**

DEPRECATED: sound system alarm circuit

transmission path that connects the FACIE to loudspeaker, AAD or VAD

2.1.45**fire alarm condition**

DEPRECATED: sound system alarm condition

audible voice or tone signal (recorded or live) operating in one or more emergency zones

2.1.46**fire alarm control and indicating equipment****FACIE**

DEPRECATED: sound system control and indicating equipment component that is used to

- a) receive alarm signals from an emergency detection system(s),
- b) receive audio messages from emergency microphones,
- c) determine signal priority and routing,
- d) cause audible warning signals to be broadcast to emergency loudspeaker zones,
- e) automatically supervise the correct functioning of the system and give audible and visible warning of specified faults, and
- f) provide manual controls and visual status indicators

2.1.47

fire alarm output control

DEPRECATED: sound system output control

manual control used to cause one or more emergency zones to sound an audible signal

2.1.48

fire alarm receiving station

centre, on or remote from the protected premises, from which the necessary fire protection or firefighting measures can be initiated at any time on receipt of a fire alarm signal

Note 1 to entry: See [Figure 1](#), item F.

2.1.49

fire alarm routing equipment

intermediate equipment which routes an alarm signal from FDCIE (see [Figure 1](#), item B) to a fire alarm receiving station (see [Figure 1](#), item F)

Note 1 to entry: See [Figure 1](#), item E.

2.1.50

fire alarm signal

DEPRECATED: sound system alarm signal

signal, which may be electrical, mechanical, audible, visual, etc. to show that a hazard from fire exists in an area

Note 1 to entry: The signal may be local, addressed to the occupants of the area, or remote, addressed to other people or organizations from whom assistance may be required.

2.1.51

fire alarm signalling device

equipment, not incorporated in the control and indicating equipment (see [Figure 1](#), items B and M) which is used to give a warning of fire, e.g. AAD or VAD

Note 1 to entry: See [Figure 1](#), item C.

2.1.52

fire alarm system

DEPRECATED: sound system for emergency purposes application consisting of

- FACIE,
 - power supply equipment,
 - loudspeakers,
 - other equipment necessary for the operation of the system,
- and interconnected by transmission paths

2.1.53**fire alarm zone**

DEPRECATED: emergency loudspeaker zone

subdivision of the premises composed of one or more acoustically distinguishable areas, such that the occurrence of an emergency within it is indicated separately from any other subdivision

2.1.54**fire alarm zone output**

DEPRECATED: sound system zone output

all the necessary connections between the FACIE and the fire alarm circuits to broadcast emergency messages to an alarm zone

2.1.55**fire detection and alarm system****FDAS**

group of components including control and indicating equipment which, when arranged in (a) specified configuration(s), is capable of detecting, indicating a fire and giving signals for appropriate action

2.1.56**fire detection control and indicating equipment****FDCIE**

equipment through which points may be supplied with power and which

- a) is used to receive signals from detectors and/or manual call point, and to activate a fire alarm signal, and which may also be required to indicate the location of the fire and to record any of this information,
- b) if required, is able to pass on the fire detection signal through fire alarm routing equipment (see [Figure 1](#), item E) to, for example, the firefighting service or, through the fire protection control equipment (see [Figure 1](#), item G), to, for example an automatic extinguishing installation,
- c) is used to monitor automatically the correct function of the FDAS and give audible and visible warning of specified faults, and
- d) if required, is able to pass on the fault signals through fault routing equipment (see [Figure 1](#), item J) to a fault warning receiving station

2.1.57**fire detection zone**

geographic sub-division of the protected premises in which one or more points are installed and for which a common zonal indication is provided

2.1.58**fire detector**

component that contains at least one sensor which constantly or at frequent intervals monitors at least one suitable physical and/or chemical phenomenon associated with fire, and that provides at least one corresponding signal to the FDCIE (see [Figure 1](#), item B)

Note 1 to entry: See [Figure 1](#), item A.

Note 2 to entry: The decision to give that alarm of fire or to operate fire protection equipment may be made at the detector or at the FDCIE.

2.1.59**fire protection control equipment****FPCE**

component used to actuate fire protection equipment (see [Figure 1](#), item H) after receiving a signal from the FDCIE (see [Figure 1](#), item B)

Note 1 to entry: See [Figure 1](#), item G.

2.1.60

fire protection equipment

fire control or firefighting equipment or system (e.g. control of smoke doors, dampers, fans or an automatic extinguishing installation)

Note 1 to entry: See [Figure 1](#), item H.

2.1.61

first alarm signal

signal from a fire detector or manual call point which is interpreted as a fire alarm and following which, the FDCIE (see [Figure 1](#), item B) enters a first alarm state

2.1.62

first alarm state

state of the FDCIE (see [Figure 1](#), item B) following the receipt of a first alarm signal during which mandatory functions of the FDCIE might be inhibited

2.1.63

flame detector

fire detector which responds to the radiation emitted by flames from a fire

2.1.64

float voltage

voltage that when applied to a battery will maintain the battery in a fully charged state

2.1.65

fully charged voltage

highest voltage which characterises a fully charged battery

Note 1 to entry: The fully charged voltage is specified by the battery manufacturer.

2.1.66

functional condition

condition characterized by its indication

2.1.67

heat detector

fire detector sensitive to an increase in temperature

2.1.68

hierarchical system

networked system in which one control and indicating equipment is designated as the main control-and-indicating equipment, and in which the main control-and-indicating equipment is able to

- receive signals from and/or transmit signals to the control-and-indicating equipment of a subsystem, and
- indicate the status of the control-and-indicating equipment of a subsystem

2.1.69

ionization smoke detector

fire detector sensitive to combustion products capable of affecting ionization currents within the detector

2.1.70

indication

information given by an indicator

2.1.71

indicator

device which can change its state to give information

2.1.72**infrared (IR) detector**

flame detector responding only to radiation having wavelengths greater than 850 nm

2.1.73**input/output device**

component which is connected to a transmission path and is used to receive and/or transmit information to, from, or within the FDAS

Note 1 to entry: See [Figure 1](#), item N.

2.1.74**integrated power supply equipment**

equipment for which it is not possible for the manufacturer to specify the output voltage range(s) of the power supply input voltage range(s) and if in the case of a defective power supply equipment (see [Figure 1](#), item L), where the repair by replacement of the power supply equipment involves replacement of a part or the whole other equipment

2.1.75**intelligibility**

measure of the proportion of the content of a speech message that can be correctly understood

Note 1 to entry: Satisfactory intelligibility requires adequate audibility and adequate clarity.

2.1.76**least sensitive orientation**

point of rotation, relative to air flow, about the vertical axis where a fire detector produces the maximum response threshold value

2.1.77**line-type detector**

fire detector that responds to the phenomenon monitored in the vicinity of a continuous line

2.1.78**line-type heat detector**

fire detector that responds to heat applied to any point along the length of the sensing element or in the vicinity of the sensing element

2.1.79**line-type smoke detector**

fire detector consisting of at least a transmitter and a receiver and can include reflector(s), for the detection of smoke by the attenuation and/or changes in attenuation of an optical beam

2.1.80**locally resettable detector**

resettable fire detector that can be restored to its normal state of readiness to detect by a manual operation carried out at the detector

2.1.81**log**

record of essential events relating to the FDAS

2.1.82

loudspeaker

transducer that converts electrical energy into acoustical energy, comprised of one or more drive units, one or more enclosures, a cable termination block and relevant devices such as filters, transformers and any passive element

Note 1 to entry: Some loudspeakers are a combination of one or more loudspeaker housing(s) and a termination box interconnected by a cable. The loudspeaker housing(s), cable(s), and terminal box should be considered to be “the loudspeaker” for the purposes of ISO 7240. Examples of such loudspeakers include pendant types and loudspeakers with mechanically adjustable orientation such as horn or column loudspeakers and loudspeaker arrays.

2.1.83

m

absorbance index

measured light attenuation characterizing the concentration of particulates in smoke or an aerosol

2.1.84

mandatory

qualification applied to those functions required to be provided and the functions' requirements and to the requirements of any optional functions that have requirements, if such optional functions are provided

2.1.85

manual call point

component for the manual initiation of an alarm

Note 1 to entry: See [Figure 1](#), item D.

2.1.86

manual fire alarm system

system (not containing fire detectors) in which an alarm of fire can only be initiated manually

2.1.87

maximum application temperature

maximum temperature that can be expected to be experienced, even for short periods of time, in the absence of a fire condition

2.1.88

module

part of a software program that fulfils specified functions

2.1.89

multiband detector

flame detector that responds to radiation in more than one distinct wavelength range where each range may contribute to the alarm decision

Note 1 to entry: The alarm decision may be based on any arithmetic or logical combination of the individual signals.

2.1.90

multipoint detector

fire detector that respond to the phenomenon monitored in the vicinity of more than one compact sensor, such as thermocouples

2.1.91

multisensor detector

fire detector incorporating sensors within one mechanical housing which responds to more than one physical phenomena of fire, e.g. smoke and heat, smoke and gas, or heat and gas

Note 1 to entry: The mechanism for actuating alarm signals or for operating automatic fire protection equipment may be located with the detector or in another part of the FDAS, for example at the FDCIE.

2.1.92**multistate detector**

fire detector which gives one of a limited number (greater than two) of output states relating to a normal condition, a fire alarm condition, and other abnormal conditions

2.1.93**networked fire detection and alarm system**

FDAS in which more than one control and indicating equipment are interconnected and able to exchange information

2.1.94**non-detachable detector**

fire detector which is designed to be mounted directly to a surface without the use of a mounting base

2.1.95**non-resettable detector with exchangeable elements**

fire detector which after response requires the renewal of a component or components to restore it to its normal state of readiness to detect

2.1.96**non-resettable detector without exchangeable elements**

fire detector which after response cannot be restored from its alarm state to its normal state of readiness to detect, and must be replaced

2.1.97**non-volatile memory**

memory elements which do not require the presence of an energy source for the retention of their contents

2.1.98**phased evacuation**

plan using the fire alarm system to broadcast warning signals in a sequence most suitable to promote the rapid and orderly evacuation of building occupants

2.1.99**photoelectric smoke detector**

fire detector sensitive to combustion products capable of affecting the absorption or scattering of radiation in the infrared, visible, and/or ultraviolet region of the electromagnetic spectrum

2.1.100**planning**

paper work, studies, and analysis concerning the design of a FDAS before starting wiring and hardware installation as, e.g.:

- design considerations;
- detection concept;
- drawings;
- quotations

2.1.101**point**

component (see [Figure 1](#), items A and D) connected to a detection circuit able to transmit, or receive information in relation to fire detection

2.1.102**point detector**

fire detector that responds to the phenomenon monitored in the vicinity of a compact sensor

2.1.103

power supply

source of power for control and indicating equipment (see [Figure 1](#), items B and M) and for other components, including those items fed with power from the control and indicating equipment

Note 1 to entry: The power supply may include multiple power supplies (e.g. electricity from mains and standby sources).

Note 2 to entry: See [Figure 1](#), item L.

2.1.104

project plan

layout of the whole wiring plan including the indication of the location of all components of the FDAS

2.1.105

program

software necessary to comply with at least the requirements of ISO 7240 (all parts), including initializing data, reset and interrupt vectors, operating code, and declarations

2.1.106

rate-of-rise detector

fire detector which initiates an alarm when the rate of change of the measured phenomenon with time exceeds a certain value for a specified time

2.1.107

receiving station

cf. *fire alarm receiving station* ([2.1.48](#)) or *fault warning receiving station* ([2.1.40](#))

2.1.108

remotely resettable detector

fire detector that can be restored to its normal state of readiness to detect by an operation carried out remotely from the detector

2.1.109

reset

operation capable of terminating the fire alarm condition and/or the fault warning condition

2.1.110

resettable detector

fire detector which after response and on cessation of the conditions that caused the response, may be restored from its alarm state to its normal state of readiness to detect, without the renewal of any component

2.1.111

routing equipment

cf. *fire alarm routing equipment* ([2.1.49](#)) or *fault warning routing equipment* ([2.1.39](#))

2.1.112

running data

alterable data subject to temporary modification during operation, either automatically or by manual controls

2.1.113

self-resetting detector

resettable detector that will automatically restore itself to its normal state of readiness to detect

2.1.114

sensing assembly

those parts of the detector that are required in order to produce an electrical change in response to changes in the concentration of one of the sensed inputs

2.1.115**sensor response**

defined change of the output signal of a sensing element

Note 1 to entry: The output signal may be a response to combustion or may result from environmental influences such as temperature, wind, air pressure, electromagnetic irradiation, etc.

2.1.116**separate**

physically separate and exclusively provided for the purpose or purposes stated in ISO 7240 (all parts)

2.1.117**signalling device**

cf. *fire alarm signalling device* ([2.1.51](#))

2.1.118**signals**

sounds and indications of fire within the FDAS

2.1.119**silencing**

manual operation to switch off the audible signal of a sounding device which is capable of being automatically re-sounded by a new event

2.1.120**site-specific data**

alterable data required for the equipment to operate in a defined configuration

2.1.121**smoke detection equipment for ducts****SDED**

apparatus with an integral or associated point-type smoke detector that samples the air moving in a duct and detects smoke in the sample

2.1.122**smoke detector**

fire detector sensitive to particulate products of combustion and/or pyrolysis suspended in the atmosphere

2.1.123**smoke-response value**

A_{SR}

aerosol density in the proximity of a test specimen at the moment that it generates a reference signal in a smoke tunnel

2.1.124**sound pattern**

predefined acoustic alarm signal

Note 1 to entry: Sound pattern is also often referred to as “tone”.

2.1.125**standby power source**

supply of voltage and current used by power supply equipment when the main power source is unavailable

Note 1 to entry: Standby power sources are typically batteries, but might also be other sources alternate to the AC mains, such as an uninterruptible power supply installed in a building.

2.1.126**static detector**

fire detector which initiates an alarm when the magnitude of the measure phenomenon exceeds a static or fixed value for a specified period of time

2.1.127

static response temperature

temperature at which a heat detector would produce an alarm signal if subjected to a vanishingly small rate of rise of temperature

2.1.128

supervisory sounder

audible device on a piece of equipment used for drawing attention to a change of status

Note 1 to entry: Supervisory sounders are often mounted within FACIE and FDCIE.

2.1.129

temperature-response value

temperature in the proximity of a heat detector at the moment that it generates a reference signal

2.1.130

transmission path

DEPRECATED: connection elements

connection, external to the cabinet of the control and indicating equipment (see [Figure 1](#), items B and M), for the transmission of information and/or power

- between FDCIE or FACIE and other components of a FDAS, and/or
- between parts of control and indicating equipment contained in different cabinets

2.1.131

two-state detector

fire detector which gives one of two output states relating to either normal condition or fire alarm condition

2.1.132

typical application temperature

temperature that can be expected to be experienced for long periods of time in the absence of a fire condition

2.1.133

ultra-violet (UV) detector

flame detector responding only to radiation having wavelengths less than 300 nm

2.1.134

video fire detector

fire detector which analyses video images to detect the presence of smoke and/or flame

Note 1 to entry: The video fire detector might be in one or more cabinets.

2.1.135

visual alarm device

VAD

component which generates a flashing light to signal to the occupants of a building that a fire alarm condition exists

2.1.136

volatile memory

memory elements which require the presence of an energy source for the retention of their contents

2.1.137

volume control

means for adjusting audible sound pressure level

2.1.138

warning

important notice concerning any change of status that demands attention or activity

2.1.139**warning signal**

alert signal or evacuate signal or a combination of alert and evacuate signals

2.1.140**window**

part or all of an alphanumeric display used for information relating to one functional condition at a given time

Note 1 to entry: A subdivision of the display may be realized either by mechanical separation, or under software control

2.1.141**y**

dimensionless variable, reflecting the change in the current flowing in an ionization chamber as a known function of the concentration of particulates in the smoke or aerosol

2.1.142**zone**

fire detection zone or fire alarm zone

2.2 Abbreviated terms

AAD	audible alarm device
FACIE	fire alarm control and indicating equipment
FDAS	fire detection and alarm system
FDCIE	fire detection control and indicating equipment
FPCE	fire protection control equipment
IR	infrared
SDED	smoke detection equipment for ducts
UV	ultraviolet
VAD	visual alarm device

3 Functions

3.1 Functions are performed by components which are interlinked using transmission paths to achieve the overall design objectives of the FDAS. The functions are shown in [Figure 1](#).

3.3 Functionality may be distributed in one or more component.

3.2 The functions of a FDAS may be grouped to form subsystems such as a fire detection subsystem and a fire alarm subsystem.

3.4 Functions may be complemented by ancillary equipment to achieve the FDAS design goals.

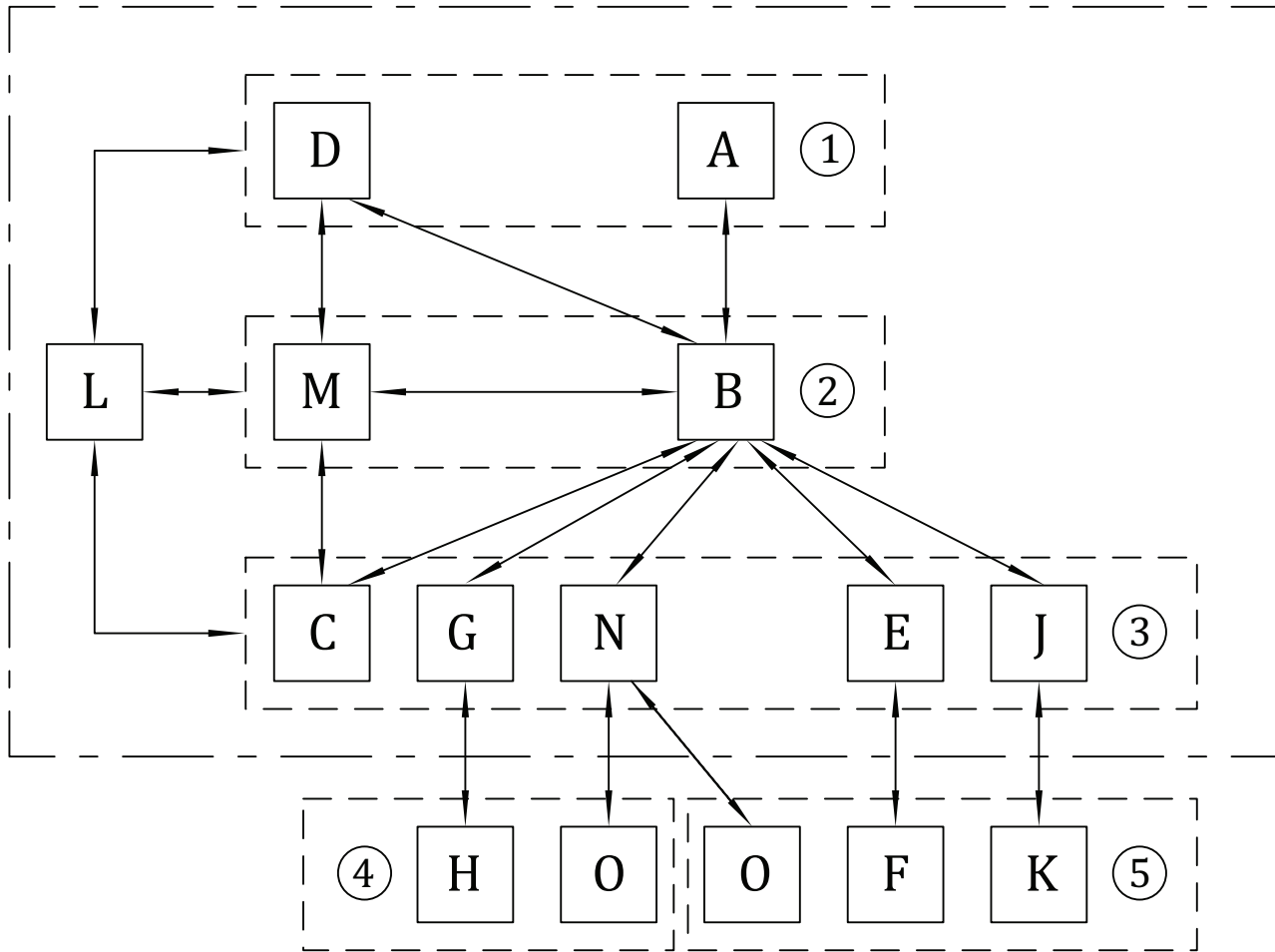

Key

- | | | | |
|---|--|---|--|
| 1 | actuation functional group | G | fire protection control function |
| 2 | control and indication functional group | H | fire protection function |
| 3 | action functional group | J | fault warning routing function |
| 4 | local functions associated with the FDAS | K | fault warning receiving function |
| 5 | remote functions associated with the FDAS | L | power supply function |
| A | detection function | M | fire alarm control and indication function |
| B | fire detection control and indication function | N | ancillary input or output function |
| C | fire alarm signalling function | O | ancillary management function |
| D | manual initiating function | | — · — · — · — functions included in the FDAS |
| E | fire alarm routing function | | ----- functional group |
| F | fire alarm receiving function | | ↔ exchange of information |

Figure 1 — Fire detection and alarm system functions

