

---

---

**Wheelchairs —**

**Part 25:  
Batteries and chargers for powered  
wheelchairs**

*Fauteuils roulants —*

*Partie 25: Batteries et chargeurs pour fauteuils roulants motorisés*



Reference number  
ISO 7176-25:2013(E)

© ISO 2013



**COPYRIGHT PROTECTED DOCUMENT**

© ISO 2013

All rights reserved. Unless otherwise specified, no part of this publication may be reproduced or utilized otherwise in any form or by any means, electronic or mechanical, including photocopying, or posting on the internet or an intranet, without prior written permission. Permission can be requested from either ISO at the address below or ISO's member body in the country of the requester.

ISO copyright office  
Case postale 56 • CH-1211 Geneva 20  
Tel. + 41 22 749 01 11  
Fax + 41 22 749 09 47  
E-mail [copyright@iso.org](mailto:copyright@iso.org)  
Web [www.iso.org](http://www.iso.org)

Published in Switzerland

# Contents

Page

|   |           |
|---|-----------|
| <b>Foreword</b> .....   | <b>iv</b> |
| <b>Introduction</b> .....   | <b>vi</b> |
| <b>1 Scope</b> .....  | <b>1</b>  |
| <b>2 Normative references</b> .....                                     | <b>1</b>  |
| <b>3 Terms and definitions</b> .....                                    | <b>2</b>  |
| <b>4 Apparatus</b> .....  | <b>3</b>  |
| <b>5 Battery chargers</b> .....   | <b>5</b>  |
| 5.1 Electrical safety.....  | 5         |
| 5.2 Performance-related safety.....                                     | 6         |
| 5.3 Charging capability.....  | 9         |
| 5.4 Electromagnetic compatibility.....                                  | 11        |
| 5.5 Indicators.....   | 11        |
| <b>6 Batteries</b> .....  | <b>12</b> |
| 6.1 Requirements.....   | 12        |
| 6.2 Test method.....  | 12        |
| <b>7 Test report</b> .....  | <b>13</b> |
| 7.1 Test reports for battery chargers.....                              | 13        |
| 7.2 Test reports for batteries.....                                     | 13        |
| <b>8 User manual</b> .....  | <b>14</b> |
| 8.1 User manual for battery chargers.....                               | 14        |
| 8.2 User manual for batteries.....                                      | 15        |
| <b>9 Disclosure</b> .....   | <b>15</b> |
| <b>Annex A (informative) Recommendations for cyclic endurance</b> ..... | <b>16</b> |
| <b>Bibliography</b> .....   | <b>17</b> |

## Foreword

ISO (the International Organization for Standardization) is a worldwide federation of national standards bodies (ISO member bodies). The work of preparing International Standards is normally carried out through ISO technical committees. Each member body interested in a subject for which a technical committee has been established has the right to be represented on that committee. International organizations, governmental and non-governmental, in liaison with ISO, also take part in the work. ISO collaborates closely with the International Electrotechnical Commission (IEC) on all matters of electrotechnical standardization.

International Standards are drafted in accordance with the rules given in the ISO/IEC Directives, Part 2.

The main task of technical committees is to prepare International Standards. Draft International Standards adopted by the technical committees are circulated to the member bodies for voting. Publication as an International Standard requires approval by at least 75 % of the member bodies casting a vote.

Attention is drawn to the possibility that some of the elements of this document may be the subject of patent rights. ISO shall not be held responsible for identifying any or all such patent rights.

ISO 7176-25 was prepared by Technical Committee ISO/TC 173, *Assistive products for persons with disability*, Subcommittee SC 1, *Wheelchairs*.

ISO 7176 consists of the following parts, under the general title *Wheelchairs*:

- *Part 1: Determination of static stability*
- *Part 2: Determination of dynamic stability of electric wheelchairs*
- *Part 3: Determination of effectiveness of brakes*
- *Part 4: Energy consumption of electric wheelchairs and scooters for determination of theoretical distance range*
- *Part 5: Determination of dimensions, mass and manoeuvring space*
- *Part 6: Determination of maximum speed, acceleration and deceleration of electric wheelchairs*
- *Part 7: Measurement of seating and wheel dimensions*
- *Part 8: Requirements and test methods for static, impact and fatigue strengths*
- *Part 9: Climatic tests for electric wheelchairs*
- *Part 10: Determination of obstacle-climbing ability of electrically powered wheelchairs*
- *Part 11: Test dummies*
- *Part 13: Determination of coefficient of friction of test surfaces*
- *Part 14: Power and control systems for electrically powered wheelchairs and scooters — Requirements and test methods*
- *Part 15: Requirements for information disclosure, documentation and labelling*
- *Part 16: Resistance to ignition of upholstered parts*
- *Part 19: Wheeled mobility devices for use as seats in motor vehicles*
- *Part 21: Requirements and test methods for electromagnetic compatibility of electrically powered wheelchairs and scooters, and battery chargers*
- *Part 22: Set-up procedures*

- *Part 23: Requirements and test methods for attendant-operated stair-climbing devices*
- *Part 24: Requirements and test methods for user-operated stair-climbing devices*
- *Part 25: Batteries and chargers for powered wheelchairs*
- *Part 26: Vocabulary*
- *Part 28: Requirements and test methods for stair-climbing devices*

## Introduction

Since the reliability and performance of an electrically powered wheelchair depend on the operation, performance and reliability of the battery set and the battery charger, it is important to ensure that wheelchair batteries and chargers are suitable for the purpose and that the wheelchair, batteries and charger are compatible. It is also important to ensure that risks arising from the use of wheelchair batteries and their chargers are eliminated or reduced as far as is practicable. Consequently, it is essential that performance requirements and safety requirements for wheelchair batteries and battery chargers are available.

Battery chargers are divided into three types: off-board, carry-on and on-board. Operating, transport and storage situations can differ for these types, so it is appropriate to apply different requirements to them.

# Wheelchairs —

## Part 25:

# Batteries and chargers for powered wheelchairs

**WARNING** — This part of ISO 7176 calls for the use of procedures that might be injurious to health if adequate precautions are not taken. It refers only to technical suitability and does not absolve those carrying out or commissioning the tests from legal obligations relating to health and safety. Prior to carrying out tests that could cause batteries or chargers to exhibit dangerous behaviour, it is recommended that the likely outcome is assessed and appropriate arrangements made to minimise risk.

## 1 Scope

This International Standard specifies requirements and test methods for batteries and battery chargers intended for use with electrically powered wheelchairs. It is applicable to lead acid batteries and chargers intended for use with them. Requirements for chargers are applicable to those with a rated input voltage not greater than 250 V a.c. and a nominal output voltage not greater than 36 V.

NOTE 1 Requirements for other battery chemistries (nickel and lithium based batteries) and suitable chargers are under consideration.

NOTE 2 Requirements regarding safety are applicable to all battery chargers intended for use with electrically powered wheelchairs.

## 2 Normative references

The following referenced documents are indispensable for the application of this document. For dated references, only the edition cited applies. For undated references, the latest edition of the referenced document (including any amendments) applies.

ISO 7176-8, *Wheelchairs — Part 8: Requirements and test methods for static, impact and fatigue strengths*

ISO 7176-21, *Wheelchairs — Part 21: Requirements and test methods for electromagnetic compatibility of electrically powered wheelchairs and scooters, and battery chargers*

IEC 60254-1, *Lead-acid traction batteries — Part 1: General requirements and methods of tests*

IEC 60254-2, *Lead-acid traction batteries — Part 2: Dimensions of cells and terminals and marking of polarity on cells*

IEC 60335-2-29, *Household and similar electrical appliances — Safety — Part 2-29: Particular requirements for battery chargers*

IEC 60529, *Degrees of protection provided by enclosures (IP Code)*

IEC 61076-2-103, *Connectors for electronic equipment — Part 2-103: Circular connectors — Detail specification for a range of multipole connectors (type 'XLR')*

SAE J1495, *Test Procedure for Battery Flame Retardant Venting Systems*

IATA *Special Provision A67*

### 3 Terms and definitions

For the purposes of this document, the terms and definitions given in ISO 7176-26 and the following apply.

**3.1  
battery**  
one or more cells fitted with devices necessary for use, for example case, terminals, marking and protective devices

[SOURCE: IEC 482-01-04]

**3.2  
lead acid battery  
lead dioxide lead battery**  
secondary battery with an aqueous electrolyte based on dilute sulphuric acid, a positive electrode of lead dioxide and a negative electrode of lead

Note 1 to entry: Lead dioxide lead batteries are often called accumulators (deprecated).

[SOURCE: IEC 482-05-01]

**3.3  
nominal voltage**  
suitable approximate value of the voltage used to designate or identify a cell, a battery or an electrochemical system

[SOURCE: IEC 482-03-31]

Note 1 to entry: For lead acid batteries the nominal voltage is usually two volts multiplied by the number of cells.

**3.4  
rated d.c. output current**  
output current assigned to the battery charger by its manufacturer

**3.5  
rated d.c. output voltage**  
output voltage assigned to the battery charger by its manufacturer

**3.6  
rated input voltage**  
supply mains voltage assigned to the battery charger by its manufacturer

**3.7  
safety hazard**  
potential source of physical injury or damage to the health of the user, other persons or animals, or damage to the surroundings, arising directly from the battery charger or battery

Note 1 to entry: Adapted from IEC 60601-1.

**3.8  
 $C_5$**   
rated capacity of the battery for a discharge time of 5 h, expressed in ampere hours

Note 1 to entry:  $C_5$  is equivalent to  $C_N$  as defined in IEC 60254-1.

Note 2 to entry: IEC 60254-1 states that the nominal capacity,  $C_N$ , is a reference value declared by the manufacturer, which is valid for a cell/battery temperature of 30 °C, a discharge time of 5 h, and a cut-off voltage  $U_f$  of 1,70 V per cell.

Note 3 to entry: The nominal capacity,  $C_N$ , can differ from the actual capacity of the battery.



**3.9** **$I_5$** 

the electric current ( $C_5 / 5$ ), expressed in amperes

Note 1 to entry: The numerical value of  $C_5$  divided by a numerical value of time in hours yields a numerical value of current.

**4 Apparatus**

**4.1 Mean current meter**, capable of measuring the arithmetic mean current supplied by a battery charger to an accuracy of 2 % of the measurement, which does not introduce a voltage drop (added to the voltage at the output connector of the battery charger) that exceeds 0,2 % of the nominal battery voltage.

NOTE 1 The measuring device may be an integral part of an electronic load as specified in [4.4](#).

NOTE 2 It is important to match the averaging time of the meter to any cyclic variations in the charging current.

**4.2 Root-mean-square (r.m.s.) current meter**, capable of measuring the r.m.s. current supplied by a battery charger to an accuracy of 2 % of the measurement, which does not introduce a voltage drop that exceeds 0,2 % of the nominal battery voltage.

NOTE The measuring device may be an integral part of an electronic load as specified in [4.4](#).

**4.3 Voltmeter**, capable of measuring the voltage supplied by a battery charger, to an accuracy of 0,1 % of the measurement.

NOTE The measuring device may be an integral part of an electronic load as specified in [4.4](#).

**4.4 Electronic load**, for simulating a battery to the extent necessary to provide the test loads for battery chargers included in the scope of this standard.

EXAMPLE [Figure 1](#) shows an outline schematic for an electronic load that can be used in constant-voltage mode or constant-current mode, with terminals for connection to the output terminals of the battery charger.

In the constant-voltage mode (switch in CV position), the circuit will keep the voltage between the load terminals substantially constant while sinking the current supplied by the battery charger.

In the constant-voltage mode the voltage at the load terminals will be given by

$$V_{REF\_U} \times \frac{R1 + R2}{R2}$$

In the constant-current mode (switch in CC position), the circuit will sink a substantially constant current with the load terminal voltage being the output voltage of the battery charger.

In constant-current mode the load current will be given by

$$\frac{V_{REF\_I}}{R_{SHUNT}}$$

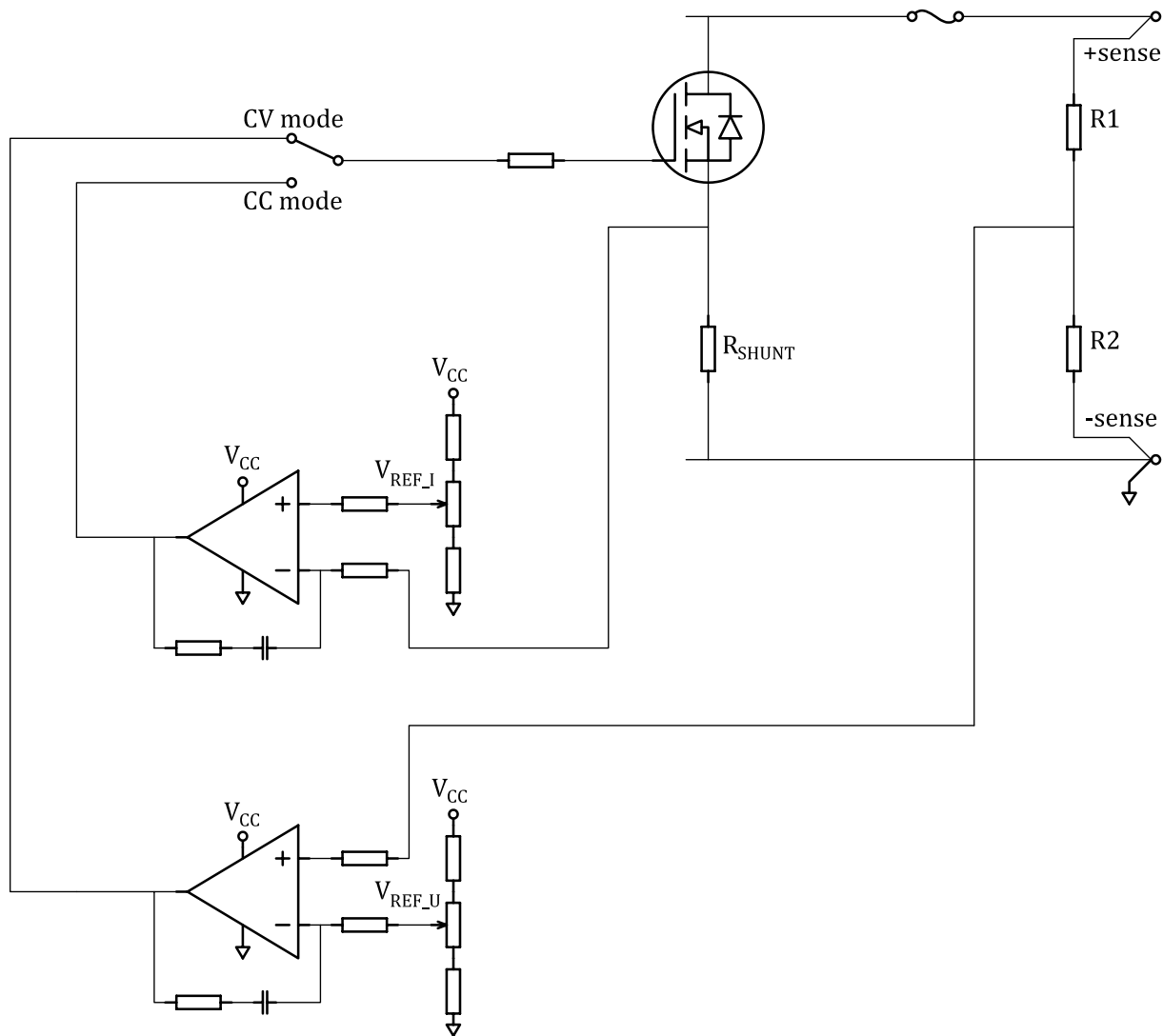

NOTE 1  $R_{SHUNT}$  may be utilized as a part of a current measuring device (4.1 and 4.2).

NOTE 2 Some battery chargers might need a voltage to be applied to the output terminals to energize or maintain their output. To initialize such chargers it will be necessary to connect a current-limited voltage source to the load terminals.

NOTE 3 It is important to confirm correct operation of the battery charger with the electronic load. For example, some battery chargers might need a capacitive load, in which case an appropriate capacitor should be added to the load terminals and correct operation confirmed.

NOTE 4 It is essential that the voltage range at the load terminals and the maximum load current are matched to the battery charger under test.

Figure 1 — Electronic load outline schematic

**4.5 Means to alter the a.c. supply voltage to a battery charger**, normally consisting of a tapped or continuously adjustable variable transformer. The means should not cause the peak supply voltage of the charger when fully loaded to differ by more than 2 % from the peak supply voltage of the charger when not loaded.

## 5 Battery chargers

### 5.1 Electrical safety

#### 5.1.1 General

It is important that battery chargers intended for use with electrically powered wheelchairs do not constitute a safety hazard when utilized in the specified environment and during foreseeable misuse.

#### 5.1.2 Requirements

**5.1.2.1** On-board and carry-on battery chargers shall meet the following requirements after being exposed to vibration as specified in [5.1.3.2](#).

**5.1.2.2** Battery chargers shall meet the requirements of IEC 60335-2-29 for class II appliances.

**5.1.2.3** Off-board battery chargers intended for use only in dry indoor areas shall provide a degree of protection not less than IPX1 as specified in IEC 60529.

**5.1.2.4** Carry-on battery chargers, installed on-board battery chargers and off-board battery chargers intended for use in places other than dry indoor areas shall provide a degree of protection not less than IPX4 as specified in IEC 60529.

#### 5.1.3 Test methods

##### 5.1.3.1 General

Test battery chargers in accordance with the applicable parts of IEC 60335-2-29 and IEC 60529. For battery chargers that have cooling fans, include locked or disconnected fans in the abnormal operation testing.

NOTE 1 An electronic load in constant-voltage mode as described in [4.4](#) may be used for loading the battery charger during testing.

NOTE 2 IEC 60335-2-29 specifies tests and inspection criteria for appliances with IP ratings.

##### 5.1.3.2 Exposure to vibration

###### 5.1.3.2.1 On-board battery chargers

Where a wheelchair intended for use with the charger is available install the on-board battery charger on the wheelchair in accordance with the charger manufacturer's instructions. Subject the wheelchair to the multi-drum fatigue test and the kerb-drop fatigue test specified in ISO 7176-8.

NOTE This may be combined with wheelchair testing in accordance with ISO 7176-8.

Alternatively, expose the on-board battery charger to vibration as specified in IEC 60335-2-29 for battery chargers for installing in caravans and similar vehicles.

###### 5.1.3.2.2 Carry-on battery chargers

Where a wheelchair intended for use with the charger is available arrange for the battery charger to be carried on the wheelchair in accordance with the charger manufacturer's instructions. Subject the wheelchair to the multi-drum fatigue test and the kerb-drop fatigue test specified in ISO 7176-8.

NOTE This may be combined with wheelchair testing in accordance with ISO 7176-8.

Alternatively, expose the carry-on battery charger to vibration as specified in IEC 60335-2-29 for battery chargers for installing in caravans and similar vehicles.

## 5.2 Performance-related safety

### 5.2.1 General

It is important that battery chargers intended for use with electrically powered wheelchairs are safe in normal use and in foreseeable misuse.

### 5.2.2 Charging connector

#### 5.2.2.1 General

It is essential that output connectors intended to be handled by the end user are safe. It is preferable that the connector is also convenient to use.

NOTE The shape of the charging connector can contribute considerably to ergonomics of use and safety of operation.

#### 5.2.2.2 Requirements

The current rating of the output connector and output cable shall exceed the maximum r.m.s. output current of the battery charger.

If an XLR connector is utilized as a charging connector the following applies:

- a) the output connector of the charger shall be male;
- b) the XLR connector shall conform to IEC 61076-2-103;
- c) where the r.m.s. output current of the battery charger is greater than 5 A the connector shall conform to the requirements for the power variant specified in IEC 61076-2-103;
- d) regardless of whether the connector has more pins, the first three pins shall be assigned as follows:
  - pin 1: battery positive;
  - pin 2: battery negative;
  - pin 3: inhibit.

#### 5.2.2.3 Test methods

Compare the r.m.s. current rating of the charging connector and cable with the r.m.s. output current of the battery charger as measured in [5.3.4.2](#).

If an XLR connector is utilized as a charging connector, confirm the requirements of 5.2.2.2 a), b), c) and d) are met by inspection.

### 5.2.3 Reverse polarity connection

#### 5.2.3.1 General

Reverse polarity connection between the battery and the battery charger could cause a fire or damage to the wheelchair control system, the battery and/or the battery charger if no reverse polarity protection is present.

#### 5.2.3.2 Requirements

There shall be no safety hazard when the battery charger is connected to a battery set with reversed polarity.

When battery chargers are tested in accordance with [5.2.3.3](#),

- the steady-state current that flows to discharge the battery shall not be greater than 100 mA,
- there shall be no damage to the battery charger, and
- following resetting and/or replacement of any circuit protection devices the battery charger shall operate as specified by the manufacturer.

NOTE This requirement complements the requirement of IEC 60335-2-29 regarding reverse polarity connection.

### 5.2.3.3 Test method

**WARNING — These tests can be hazardous. It is essential that appropriate safety precautions are taken to protect test personnel.**

- a) Add to the output cable of the battery charger a means to measure the current ([4.1](#)).
- b) Make provision for connecting the battery charger to the test battery with reversed polarity.
- c) With the battery charger disconnected from the supply mains, connect the battery to the battery charger with reversed polarity.
- d) Monitor the steady-state current in the output cable of the battery charger for a period of not less than 1 min and record whether any steady state current greater than 100 mA flows in the output cable.
- e) Disconnect the battery charger from the battery and examine the battery charger. Record any damage.
- f) If the battery charger is undamaged, reset and/or replace any circuit protection devices, if needed.
- g) Connect the battery charger to the battery with normal polarity. Connect the battery charger to the supply mains and switch on the battery charger. Check and record whether it operates correctly.
- h) With the battery charger connected to the supply mains and switched on, connect the battery to the battery charger with reversed polarity.
- i) Repeat d) to g).
- j) Switch off the battery charger and disconnect it from the supply mains.

## 5.2.4 Battery discharge

### 5.2.4.1 General

A battery charger that is disconnected from the supply mains and left connected to the battery might draw an excessive current from the battery.

### 5.2.4.2 Requirement

The current drawn from a correctly connected battery by a carry-on or off-board battery charger that is disconnected from the supply mains shall not exceed 10 mA.

NOTE On-board battery chargers are covered by ISO 7176-14.

### 5.2.4.3 Test method

Conformity is checked by adding to the output cable of the battery charger a means to measure the mean current ([4.1](#)) when the battery charger is connected to a test voltage equal to the nominal voltage of the battery for which the battery charger is intended,  $\pm 0,1$  V.

NOTE A power supply may be the source of the test voltage.

## 5.2.5 Battery charger options

### 5.2.5.1 General

It is important that the output voltage of the battery charger, the charging characteristics and any other settings of the battery charger are compatible with the battery set to be charged and that they cannot be changed inadvertently.

### 5.2.5.2 Requirements

It shall not be possible to change the output voltage, the charging characteristics or other settings of the battery charger without the aid of a tool, key entry combination or similar means for restricting access. If the means for restricting access is other than a tool, it shall not consist of operations which are performed in normal use of the battery charger.

### 5.2.5.3 Test method

The requirement is confirmed by inspection.

## 5.2.6 Charging a faulty battery set

### 5.2.6.1 General

Excessive gassing and heating can occur if a faulty battery set is being recharged. It is desirable to reduce the risks related to charging faulty battery sets as far as possible.

### 5.2.6.2 Requirements

Battery chargers shall cease charging a faulty battery set, i.e. one where the terminal voltage does not increase normally during charging, not more than 12 h after the commencement of charging.

### 5.2.6.3 Test method

Prepare a constant-voltage load (4.4) for connection to the battery charger (as a simulated battery).

Set up the load with a constant voltage not greater than the nominal voltage of the battery set for which the battery charger is intended.

Connect into the output cable of the battery charger a device (4.1) that will detect the flow of current between the battery charger and the constant-voltage load.

Set up a timing device to measuring the time for which current flows after charging has commenced.

Connect the battery charger to supply mains.

Switch on the charger.

Connect the charger to the constant-voltage load.

Measure the time taken before the output current terminates and record whether or not the time is within the required period.

## 5.2.7 Thermal runaway

Under consideration.

## 5.3 Charging capability

### 5.3.1 General

It is desirable that the battery set of a wheelchair can be completely recharged overnight.

As a rough approximation, when a battery set of capacity  $C_5$  has been discharged to the cut off voltage specified by the battery manufacturer at a current  $I_5$ , a battery charger with an output current of  $0,5 \times I_5$  will be able to recharge it to  $0,8 \times C_5$  in a period of 8 h.

A typical charging process is made up of the following phases:

- a bulk charging (constant current) phase, where the charging current is controlled by the battery charger;
- an absorption (constant voltage) phase, during which the voltage is controlled by the battery charger and the remaining part of the capacity is recharged while the charging current decreases;
- an optional equalizing phase, during which the charge in the individual cells is balanced.

To provide a predictable charging time and to ensure proper charging of the battery, it is essential that the output current and the output voltage of the battery charger are independent of mains voltage variations.

NOTE 1 The duration of the bulk charging phase is influenced by the output voltage of the charger and the voltage drop in the wiring. Consequently, it is important that there is a correct match between the charger, wheelchair charging circuitry and battery.

NOTE 2 To complete the charging process the absorption phase must come to an end. It is important to avoid repeated incomplete recharging as this could cause the battery set to degrade.

### 5.3.2 Requirements

#### 5.3.2.1 Charging current

NOTE 1 This requirement concerns the bulk charge phase.

The required minimum output current for a battery charger depends on the  $C_5$  of the largest capacity battery for which it is intended.

The battery charger shall supply an output current of not less than  $0,5 \times I_5$  when supplied by the nominal mains voltage  $\pm 6\%$ .

The battery charger shall not supply an output current greater than 110 % of the rated output current when supplied by the nominal mains voltage  $\pm 6\%$ .

NOTE 2 Attention should be paid not to exceed the current specification of the battery set for which the charger is intended.

NOTE 3 Attention should be paid not to exceed the current specification of the wheelchair charging circuitry for which the charger is intended.

#### 5.3.2.2 Charging voltage

NOTE This requirement concerns the absorption charge phase.

The battery charger shall supply an output voltage as specified by the charger manufacturer within a tolerance of  $\pm 0,5\%$  when supplied by the nominal mains voltage  $\pm 6\%$ .

### 5.3.3 Preparation for test

Record the rated d.c. output voltage,  $U_{\text{chg}}$ .

Calculate the minimum output voltage,  $U_{\text{chg, min}} = U_{\text{chg}} \times 0,995$ .

Calculate the maximum output voltage,  $U_{\text{chg, max}} = U_{\text{chg}} \times 1,005$ .

Record the maximum battery capacity  $C_5$  specified by the charger manufacturer.

Calculate the required output current of the battery charger,  $I_{\text{chg, min}} = 0,5 \times I_5$ .

### 5.3.4 Test methods

#### 5.3.4.1 Charging current set-up

Prepare a constant-voltage load (4.4) for connection to the battery charger (as a simulated battery).

Set up the load with a constant voltage equal to  $U_{\text{chg}} \times (0,97 \pm 0,01)$ .

Connect into the output cable of the battery charger a device (4.1) to measure the mean current from the battery charger to the constant-voltage load.

Connect into the output cable of the battery charger a device (4.2) to measure the r.m.s. current from the battery charger to the constant-voltage load.

Set up a means to alter the a.c. supply voltage (4.5) and adjust the supply voltage to be equal to the rated input voltage.

Connect the mains plug of the battery charger to the means to alter the a.c. supply voltage (4.5).

Switch on the charger.

Connect the charger to the constant-voltage load.

Wait for 5 min.

#### 5.3.4.2 R.M.S. output current

While altering the a.c. supply voltage between the limits defined as the nominal mains supply voltage  $\pm 6\%$ , measure and record the maximum r.m.s. value of the output current of the battery charger.

The battery charger fails the test if the maximum r.m.s. value of the output current exceeds the specification of the output connector or output cable.

The battery charger fails the test if the maximum r.m.s. value of the output current exceeds 110 % of the rated output current.

#### 5.3.4.3 Mean output current

While altering the a.c. supply voltage between the limits defined as the nominal mains supply voltage  $\pm 6\%$ , measure the arithmetic mean output current of the battery charger.

The battery charger fails this test if the mean output current drops below  $I_{\text{chg, min}}$  as calculated in 5.3.3.

#### 5.3.4.4 Thermal stability

Adjust the supply voltage to be equal to the nominal mains supply voltage + 6 %. Conduct the test at the maximum operating temperature specified by the charger manufacturer, +0 –5 °C.

Measure and record the arithmetic mean output current for four hours (to establish maximum temperature).

The battery charger fails this test if the output current drops below  $I_{\text{chg, min}}$  as defined in 5.3.3 during the test.



#### 5.3.4.5 Charging voltage

Prepare a constant-current load (4.4) for connection to the battery charger (as a simulated battery).

To simulate the absorption charge phase (see 5.3.1), set up the load with a constant current equal to  $(0,5 \pm 0,05) \times I_{\text{chg, min}}$ .

Connect a voltmeter (4.3) as close as possible to the output connector of the battery charger to measure the output voltage of the battery charger.

Set up a means to alter the a.c. supply voltage (4.5) and adjust the supply voltage to be equal to the nominal supply voltage specified by the charger manufacturer.

Connect the mains plug of the battery charger to the means to alter the a.c. supply voltage (4.5).

Switch on the charger.

Connect the charger to the constant-current load.

While altering the a.c. supply voltage between the limits defined as the nominal mains voltage  $\pm 6\%$ , measure the output voltage of the battery charger.

**NOTE** If a capacitor is connected to the terminals of the constant-current load, attention must be paid to the rate of change of the output voltage.

The battery charger fails this test if the output voltage is less than  $U_{\text{chg, min}}$  or greater than  $U_{\text{chg, max}}$  as calculated in 5.3.3.

### 5.4 Electromagnetic compatibility

#### 5.4.1 General

Battery chargers intended for use with electrically powered wheelchairs should operate without producing excessive electromagnetic disturbances and without unacceptable degradation of performance in the presence of electromagnetic disturbances that can be expected in the anticipated environment.

#### 5.4.2 Requirements

Battery chargers shall meet the applicable requirements of ISO 7176-21.

#### 5.4.3 Test methods

Follow the set-up procedures and test methods specified in ISO 7176-21.

### 5.5 Indicators

#### 5.5.1 General

It is important that users are able to check the status of the battery charger.

#### 5.5.2 Requirements

Indications shall be provided for the following conditions:

- mains on;
- charging commenced;
- charging completed;

— fault present.

The indication for the mains-on condition shall be separate from all other indications.

Indicators for other conditions may be provided. The meaning of all indicators shall be explained in detail in the instructions for use.

### **5.5.3 Test method**

The requirements are confirmed by inspection.

## **6 Batteries**

### **6.1 Requirements**

#### **6.1.1 Endurance and charge retention**

Batteries shall meet the requirements of IEC 60254-1 with the exception that the charge retention test shall be performed.

Cyclic endurance of batteries should not be less than 300 cycles when they are tested in accordance with IEC 60254-1. The manufacturer shall declare the cyclic endurance.

A declaration of conformity with IEC 60254-1 shall be available.

Batteries shall conform to SAE- J1495.

NOTE This is to minimize risk of explosion.

Batteries shall meet the puncture resistance requirements specified in IATA Special Provision A67.

#### **6.1.2 Marking**

Batteries shall be marked clearly and durably with

- a) the name and/or trade mark of the manufacturer,
- b) the type reference,
- c) the nominal voltage,
- d) the rated capacity  $C_5$ ,
- e) the date of manufacture,
- f) polarity markings adjacent to each terminal as specified in IEC 60254-2.

### **6.2 Test method**

The declaration of conformity is checked by inspection.

The marking is checked by inspection.

## 7 Test report

### 7.1 Test reports for battery chargers

Test reports for battery chargers shall contain the following information:

- a) the name and address of the testing organization;
- b) a unique reference for the battery charger tested (e.g. serial number);
- c) the dates of testing;
- d) a statement that the tests have been carried out in accordance with ISO 7176-25:2013;
- e) the name and address of the battery charger manufacturer;
- f) the type reference of the battery charger;
- g) the specification for the battery charger, including
  - the rated input voltage/frequency range,
  - the rated d.c. output current,
  - the rated d.c. output voltage,
  - the operating temperature range,
  - the types of the batteries that can be charged, and
  - the rated capacity  $C_5$  of the batteries that can be charged;
- h) if the battery charger is on-board and installed on a wheelchair
  - the name and address of the wheelchair manufacturer, and
  - the type reference of the wheelchair;
- i) the ambient temperature during each test;
- j) a statement as to which requirements were met by the battery charger;
- k) a statement as to which requirements were not met by the battery charger.

### 7.2 Test reports for batteries

Test reports for batteries shall contain the following information:

- a) the name and address of the testing organization;
- b) a unique reference for the battery tested (e.g. serial number);
- c) the dates of testing;
- d) a statement that the tests have been carried out in accordance with ISO 7176-25:2013;
- e) the name and address of the battery manufacturer;
- f) the type reference of the battery;
- g) the specification for the batteries, including
  - the type,

- the rated capacities  $C_5$ ,
  - dimensions, and
  - charging and discharging specifications;
- h) a statement as to which requirements were met by the batteries;
- i) a statement as to which requirements were not met by the batteries.

## 8 User manual

### 8.1 User manual for battery chargers

A user manual shall be supplied with each battery charger. It may be incorporated into the wheelchair user manual.

User manuals for battery chargers shall include the following information:

- a) if the battery charger is off-board, carry-on or on-board but uninstalled, the type reference of the battery charger;
- b) if the battery charger is on-board and installed, the type reference of the wheelchair;
- c) a general specification which includes
- the intended use of the battery charger: on-board, carry-on or off board,
  - the rated input voltage range,
  - the rated d.c. output current,
  - the rated d.c. output voltage,
  - the operating temperature range,
  - the types of the batteries that can be charged,
  - the rated capacity  $C_5$  of the batteries that can be charged,
  - the environmental protection rating, and
  - the assignment of charging connector pins;
- d) the rated current of any user-accessible protective fuses;
- e) safety warnings, including warnings that
- users should read the instructions before attempting to use the battery charger,
  - the battery charger is intended for indoor use and is not to be exposed to rain or other sources of moisture (unless the environmental protection rating of the battery charger is at least IPX4),
  - explosive gasses can be generated while charging, so the wheelchair and battery charger are to be kept away from sources of ignition, such as flames and sparks,
  - charging is carried out with the wheelchair in a space at least twice its volume, with sufficient ventilation that there is no hazard due to build-up of flammable gas,
  - only batteries of the specified type and capacity are to be charged,
  - off-board battery chargers are not to be carried on wheelchairs;

- f) operating instructions, including the following:
  - an explanation of the function of indicators,
  - an explanation that occasional use of the wheelchair prior to charging complete indication is acceptable if the need is urgent,
  - the order of disconnection of the battery charger from the supply mains and wheelchair,
  - an explanation of the automatic charging function, stating any limitations, and
  - basic fault finding information;
- g) sales and service information, including
  - the name and address of the battery charger manufacturer, if the charger is sold separately, and
  - the names, addresses and telephone numbers of service organisations.

## 8.2 User manual for batteries

User manuals for wheelchair batteries shall include the following information:

- a) the cycle life in accordance with IEC 60254-1;
- b) warranty information;
- c) instructions for installation and maintenance;
- d) where applicable, information concerning performance at low temperatures and any related precautions;
- e) precautions regarding the battery as a source of explosive gas (e.g. ventilation, fire risk);
- f) sales and service information, including
  - the name and address of the battery manufacturer, if the battery is sold separately, and
  - the names, addresses and telephone numbers of service organisations.

## 9 Disclosure

The following information shall be disclosed as specified in ISO 7176-15:

- whether the battery charger met the requirements of ISO 7176-25:2013 and
- whether the batteries met the requirements of ISO 7176-25:2013.

## **Annex A** **(informative)**

### **Recommendations for cyclic endurance**

#### **A.1 General**

Batteries for home medical equipment applications are rated by the number of charge-discharge cycles they can undergo before their capacity falls below a predetermined percentage of the rated capacity.

The cyclic endurance of batteries, measured as specified in IEC 60254-1, is intended to be disclosed and used to compare batteries to determine whether they are suitable for a particular application.

#### **A.2 Recommendations**

Batteries which meet the cyclic endurance test of IEC 60254-1 with not less than 300 cycles should be considered for active user applications in electrically powered wheelchairs, including scooters.

.....

## Bibliography

- [1] IEC 60050-482, *International Electrotechnical Vocabulary — Part 482: Primary and secondary cells and batteries*
- [2] IEC 60601-1, *Medical electrical equipment — Part 1: General requirements for basic safety and essential performance*

.....

---

---

**ICS 11.180.10**

Price based on 17 pages