

INTERNATIONAL
STANDARD

ISO
7176-13

First edition
1989-08-01

Wheelchairs —

Part 13 :
Determination of coefficient of friction of test
surfaces

Fauteuils roulants —

Partie 13 : Détermination du coefficient de frottement des surfaces d'essai



Reference number
ISO 7176-13 : 1989 (E)

Foreword

ISO (the International Organization for Standardization) is a worldwide federation of national standards bodies (ISO member bodies). The work of preparing International Standards is normally carried out through ISO technical committees. Each member body interested in a subject for which a technical committee has been established has the right to be represented on that committee. International organizations, governmental and non-governmental, in liaison with ISO, also take part in the work. ISO collaborates closely with the International Electrotechnical Commission (IEC) on all matters of electrotechnical standardization.

Draft International Standards adopted by the technical committees are circulated to the member bodies for approval before their acceptance as International Standards by the ISO Council. They are approved in accordance with ISO procedures requiring at least 75 % approval by the member bodies voting.

International Standard ISO 7176-13 was prepared by Technical Committee ISO/TC 173, *Technical systems and aids for disabled or handicapped persons*.

ISO 7176 consists of the following parts under the general title *Wheelchairs*:

- *Part 1: Determination of static stability*
- *Part 2: Determination of dynamic stability of electric wheelchairs*
- *Part 3: Determination of efficiency of brakes*
- *Part 4: Determination of energy consumption of electric wheelchairs*
- *Part 5: Determination of overall dimensions, mass and turning space*
- *Part 6: Determination of maximum speed, acceleration and retardation of electric wheelchairs*
- *Part 7: Determination of seating dimensions — Definitions and measuring methods*
- *Part 8: Static, impact and fatigue strength tests for wheelchairs*
- *Part 9: Climatic tests for electric wheelchairs*
- *Part 10: Determination of obstacle-climbing ability of electric wheelchairs*
- *Part 11: Test dummies*
- *Part 13: Determination of coefficient of friction of test surfaces*
- *Part 14: Power and controls*

© ISO 1989

All rights reserved. No part of this publication may be reproduced or utilized in any form or by any means, electronic or mechanical, including photocopying and microfilm, without permission in writing from the publisher.

International Organization for Standardization
Case postale 56 • CH-1211 Genève 20 • Switzerland

Printed in Switzerland

Wheelchairs —

Part 13 : Determination of coefficient of friction of test surfaces

1 Scope

This part of ISO 7176 specifies a test method for determining the coefficient of friction of a test surface that has a rough texture, such as unfinished concrete. In the event that the test method is used for smooth or polished surfaces, care should be exercised that the coefficient of friction is measured as being constant over the whole area of the test surface.

Several test procedures for wheelchairs, e.g. those specified in ISO 7176-1, ISO 7176-2, ISO 7176-3, ISO 7176-6 and ISO 7176-10, require that the coefficient of friction of the test surface be within specified limits.

2 Normative references

The following standards contain provisions which, through reference in this text, constitute provisions of this part of ISO 7176. At the time of publication, the editions indicated were valid. All standards are subject to revision, and parties to agreements based on this part of ISO 7176 are encouraged to investigate the possibility of applying the most recent editions of the standards listed below. Members of IEC and ISO maintain registers of currently valid International Standards.

ISO 48 : 1979, *Vulcanized rubbers — Determination of hardness (hardness between 30 and 85 IRHD)*.

ISO 4662 : 1986, *Rubber — Determination of rebound resilience of vulcanizates*.

ISO 6440 : 1985, *Wheelchairs — Nomenclature, terms and definitions*.

3 Definitions

For the purposes of this part of ISO 7176, the definitions given in ISO 6440 and the following definition apply.

test surface : Roadway, floor, support surface or plane on which a wheelchair is tested.

4 Principle

The coefficient of friction between a wheelchair and a test surface depends on the properties of the wheelchair tyres and the test surface. Since it is desirable to compare the test results of

different wheelchairs on comparable test surfaces, this test procedure has been developed in order to define the test surface in terms of the coefficient of friction using a standard method which is independent of the wheelchair being tested.

The method consists of pulling a specified block with an interface of standard rubber at a specified speed over the test surface.

5 Test apparatus

5.1 Test block

The test block shall be made from solid steel with a flat bottom surface and shall have the dimensions shown in figure 1.

The radiused end shall be fitted with a ring or similar fastening which will allow the block to be pulled across the test surface with the force acting parallel to the test surface and at a distance 50 mm below the top surface of the block.

The mass of the test block and ring with the rubber attached shall be $5 \text{ kg} \pm 0,05 \text{ kg}$.

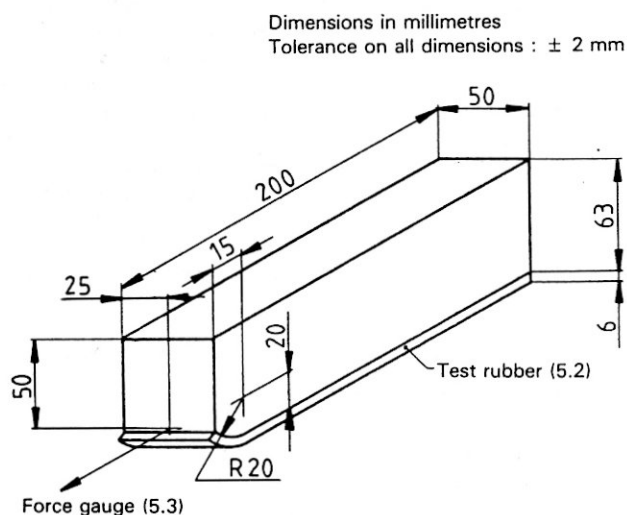

Figure 1 — Test block

5.2 Test rubber

A test rubber sheet, 50 mm × 200 mm and approximately 6 mm thick shall be attached with contact adhesive to both the planar and the curved bottom surface of the test block.

The rubber¹⁾ used for this test shall have the resilience and hardness characteristics specified in table 1, and checked respectively according to ISO 4662 and ISO 48. It shall have a smooth surface finish.

Table 1 — Resilience and hardness characteristics

| Characteristic of test rubber | Temperature, °C | | | | |
|-------------------------------|-----------------|----------|----------|----------|----------|
| | 0 | 10 | 20 | 30 | 40 |
| Resilience, % | 43 to 49 | 58 to 65 | 66 to 73 | 71 to 77 | 74 to 79 |
| Hardness, IRHD | 55 ± 5 | | | | |

NOTES

1 Care should be taken to store the rubber in a cool, dark location and in accordance with ISO 2230 : 1973, *Vulcanized rubber — Guide to storage*. No contaminants, such as oil, alcohol, degreasing agents, etc., should come into contact with the rubber at any time. Sunlight and heat are particularly damaging to the rubber.

2 Degradation of the rubber is inevitable but usually becomes significant only after several years. The rubber should be checked yearly by using the test described in this part of ISO 7176 to measure the coefficient of friction between the rubber and smooth glass. The glass should be cleaned using acetone and dried before the test. If the coefficient of friction is found to be less than 1,3, the rubber should be discarded.

5.3 Force gauge

The pulling force shall be measured by a force gauge that has been calibrated to an accuracy of ± 2 % in the range from 25 N to 100 N.

NOTE — Suitable types of force gauge include springs, dial strain gauges and hydraulic gauges.

6 Test procedure

Before the test, prepare the surface of the test rubber by lightly abrading with waterproof silicon carbide paper, grade P120, "D" weight.²⁾ Then wipe the surface clean with a dry cloth or brush. Do not use solvents or other cleaning agents. Carry out the test on three areas which are representative of the total test surface. To determine the coefficient of friction for each of these areas, pull the test block with the test rubber attached, by hand or machine, parallel to and over the test surface through a distance of 200 mm in approximately 10 s. If the test surface is a slope or ramp, conduct the test along a track parallel to the line of greatest slope. If the slope of the test surface is adjustable, conduct the test with the surface set as close as possible to the horizontal.

Record the estimated average force, F_1 , to pull the block through the 200 mm.

Repeat the test over the same area but in the opposite direction; again record the estimated average force, F_2 , in newtons.

Calculate the coefficient of friction, μ , from the following equation:

$$\mu = \frac{F_1 + F_2}{2 mg}$$

where

m is the mass of the test block and test rubber, in kilograms;

g (9,81 m/s²) is the acceleration due to gravity.

This test applies only to test surface slopes of less than 10° +1°₀, where the influence of the slope on calculations is negligible for these purposes. If the test surface is horizontal, the following condition shall be met:

$$|F_1 - F_2| < 0,1 (F_1 + F_2).$$

7 Acceptance criterion

The test surface shall be considered to be acceptable if it has a coefficient of friction between 0,75 and 1 as measured in accordance with the test method specified in this part of ISO 7176 on each of the three representative surfaces.

8 Test report

The test report shall contain the following information :

- a) a reference to this part of ISO 7176;
- b) the name and address of the test institution;
- c) a description of the test surface;
- d) all details relevant to the test method (i.e. test apparatus, test environment, temperature and relative humidity, etc.);
- e) the coefficient of friction obtained;
- f) a statement as to whether the test surface is acceptable (see clause 7);
- g) if the test surface is a slope, report the angle of the greatest slope with respect to the horizontal.

The test report shall be kept at the test institution and shall be made available as required.

1) A suitable rubber known as the "Road Research Laboratory Skid Resistance Test Rubber" may be obtained from the following supplier :
 Rubber and Plastic Research Association,
 Shawbury,
 Shrewsbury,
 Shropshire, SY4 4NR,
 United Kingdom

This information is given for the convenience of users of this part of ISO 7176 and does not constitute an endorsement by ISO of the product named. Equivalent products may be used if they can be shown to lead to the same results.

2) In some countries this paper is called "120 wet and dry".

UDC 615.478.32 : 620.1.05 : 531.43.08

Descriptors : wheel chairs, tests, friction tests.

Price based on 2 pages
