Wheelchairs —

Part 10:
**Determination of obstacle-climbing ability
of electrically powered wheelchairs**

Fauteuils roulants —

*Partie 10: Détermination de l'aptitude des fauteuils roulants électriques
à gravir les obstacles*



Reference number
ISO 7176-10:2008(E)

© ISO 2008

PDF disclaimer

This PDF file may contain embedded typefaces. In accordance with Adobe's licensing policy, this file may be printed or viewed but shall not be edited unless the typefaces which are embedded are licensed to and installed on the computer performing the editing. In downloading this file, parties accept therein the responsibility of not infringing Adobe's licensing policy. The ISO Central Secretariat accepts no liability in this area.

Adobe is a trademark of Adobe Systems Incorporated.

Details of the software products used to create this PDF file can be found in the General Info relative to the file; the PDF-creation parameters were optimized for printing. Every care has been taken to ensure that the file is suitable for use by ISO member bodies. In the unlikely event that a problem relating to it is found, please inform the Central Secretariat at the address given below.



COPYRIGHT PROTECTED DOCUMENT

© ISO 2008

All rights reserved. Unless otherwise specified, no part of this publication may be reproduced or utilized in any form or by any means, electronic or mechanical, including photocopying and microfilm, without permission in writing from either ISO at the address below or ISO's member body in the country of the requester.

ISO copyright office
Case postale 56 • CH-1211 Geneva 20
Tel. + 41 22 749 01 11
Fax + 41 22 749 09 47
E-mail copyright@iso.org
Web www.iso.org

Published in Switzerland

Foreword

ISO (the International Organization for Standardization) is a worldwide federation of national standards bodies (ISO member bodies). The work of preparing International Standards is normally carried out through ISO technical committees. Each member body interested in a subject for which a technical committee has been established has the right to be represented on that committee. International organizations, governmental and non-governmental, in liaison with ISO, also take part in the work. ISO collaborates closely with the International Electrotechnical Commission (IEC) on all matters of electrotechnical standardization.

International Standards are drafted in accordance with the rules given in the ISO/IEC Directives, Part 2.

The main task of technical committees is to prepare International Standards. Draft International Standards adopted by the technical committees are circulated to the member bodies for voting. Publication as an International Standard requires approval by at least 75 % of the member bodies casting a vote.

Attention is drawn to the possibility that some of the elements of this document may be the subject of patent rights. ISO shall not be held responsible for identifying any or all such patent rights.

ISO 7176-10 was prepared by Technical Committee ISO/TC 173, *Assistive products for persons with disability*, Subcommittee SC 1, *Wheelchairs*.

This second edition cancels and replaces the first edition (ISO 7176-10:1988), which has been technically revised.

ISO 7176 consists of the following parts, under the general title *Wheelchairs*:

- *Part 1: Determination of static stability*
- *Part 2: Determination of dynamic stability of electric wheelchairs*
- *Part 3: Determination of effectiveness of brakes*
- *Part 4: Energy consumption of electric wheelchairs and scooters for determination of theoretical distance range*
- *Part 5: Determination of dimensions, mass and manoeuvring space*
- *Part 6: Determination of maximum speed, acceleration and deceleration of electric wheelchairs*
- *Part 7: Measurement of seating and wheel dimensions*
- *Part 8: Requirements and test methods for static, impact and fatigue strengths*
- *Part 9: Climatic tests for electric wheelchairs*
- *Part 10: Determination of obstacle-climbing ability of electrically powered wheelchairs*
- *Part 11: Test dummies*
- *Part 13: Determination of coefficient of friction of test surfaces*
- *Part 14: Power and control systems for electrically powered wheelchairs and scooters — Requirements and test methods*

ISO 7176-10:2008(E)

- *Part 15: Requirements for information disclosure, documentation and labelling*
- *Part 16: Resistance to ignition of upholstered parts — Requirements and test methods*
- *Part 19: Wheeled mobility devices for use as seats in motor vehicles*
- *Part 21: Requirements and test methods for electromagnetic compatibility of electrically powered wheelchairs and scooters, and battery chargers*
- *Part 22: Set-up procedures*
- *Part 23: Requirements and test methods for attendant-operated stair-climbing devices*
- *Part 24: Requirements and test methods for user-operated stair-climbing devices*
- *Part 26: Vocabulary*

A Technical Report (ISO/TR 13570-1, *Wheelchairs — Part 1: Guidelines for the application of the ISO 7176 series on wheelchairs*) is also available, giving information on how to use the ISO 7176 standards when selecting a wheelchair and helping readers to understand the purpose for, and content of, the International Standards on wheelchairs.

Introduction

The ability of an electrically powered wheelchair to climb and descend obstacles can be an important factor in selecting the most appropriate wheelchair for a person, both in terms of access and safety.

Access may be affected by the ability of the wheelchair to safely negotiate obstacles, such as door thresholds, changes in heights of driving surfaces, and kerbs.

The heights of obstacles a wheelchair is capable of climbing can differ from the heights of those it can descend. However, it is important for wheelchair operators and prescribers to be able to know the height of an obstacle that a wheelchair can both ascend and descend. The obstacle-climbing and -descending performance of a wheelchair can also depend on the technique used to operate the wheelchair. The performance can also be affected by the use of alternative operating modes, such as four-wheel drive.

This part of ISO 7176 specifies a consistent method for determining the obstacle-climbing and -descending ability of electrically powered wheelchairs to provide comparable results.

Copyright International Organization for Standardization

Wheelchairs —

Part 10:

Determination of obstacle-climbing ability of electrically powered wheelchairs

1 Scope

This part of ISO 7176 specifies test methods for determining the ability of electrically powered wheelchairs, including scooters, intended to carry one person, with a maximum nominal speed not exceeding 15 km/h, to climb and descend obstacles.

2 Normative references

The following referenced documents are indispensable for the application of this document. For dated references, only the edition cited applies. For undated references, the latest edition of the referenced document (including any amendments) applies.

ISO 7176-11, *Wheelchairs — Part 11: Test dummies*

ISO 7176-13, *Wheelchairs — Part 13: Determination of coefficient of friction of test surfaces*

ISO 7176-15, *Wheelchairs — Part 15: Requirements for information disclosure, documentation and labelling*

ISO 7176-22, *Wheelchairs — Part 22: Set-up procedures*

ISO 7176-26, *Wheelchairs — Part 26: Vocabulary*

3 Terms and definitions

For the purposes of this part of ISO 7176, the terms and definitions given in ISO 7176-26 apply.

4 Principle

A number of tests are performed to determine the ability of electrically powered wheelchairs to negotiate obstacles such as kerbs and steps.

5 Test equipment

5.1 Test plane, a flat and hard plane such that its whole surface is contained between two imaginary horizontal parallel planes 5 mm apart and horizontal within $\pm 0,5^\circ$, and with a coefficient of friction as specified in ISO 7176-13.

NOTE A test plane capable of accommodating the test obstacle (5.2) and the test wheelchair, placed 0,5 m in front of the obstacle, and facing it, is usually sufficient.

5.2 Test obstacle, an obstacle as shown in Figure 1, which can be varied in height in increments of 5 mm to a height of 200 mm, with a relative tolerance of 5 % or a tolerance of ± 2 mm, whichever is the greater. The nominal starting height shall be 10 mm, or any multiple of 5 mm chosen by agreement between the test laboratory and the supplier of the wheelchair.

EXAMPLE The starting height could be 50 mm.

NOTE A test obstacle with a continuously adjustable height may be used.

The upper surface of the obstacle shall be sufficiently large that the wheelchair can climb on to the obstacle and come to rest with all wheels accommodated on the obstacle at the same time and sufficiently large that the wheelchair can be placed on the obstacle as described in 7.5 b).

The upper front edge of the obstacle shall be smooth and shall have a radius, r , of $3 \begin{smallmatrix} +2 \\ 0 \end{smallmatrix}$ mm (see Figure 1). The front face of the obstacle, excluding the radius at the top, shall lie between two imaginary vertical planes 4 mm apart. The angle between the front edge of the obstacle and the upper surface shall be $90^\circ \pm 1^\circ$.

The surface of the obstacle that can come into contact with the wheelchair shall have a coefficient of friction as specified in ISO 7176-13. The obstacle shall be fixed to the test plane to prevent movement of the obstacle during the test.

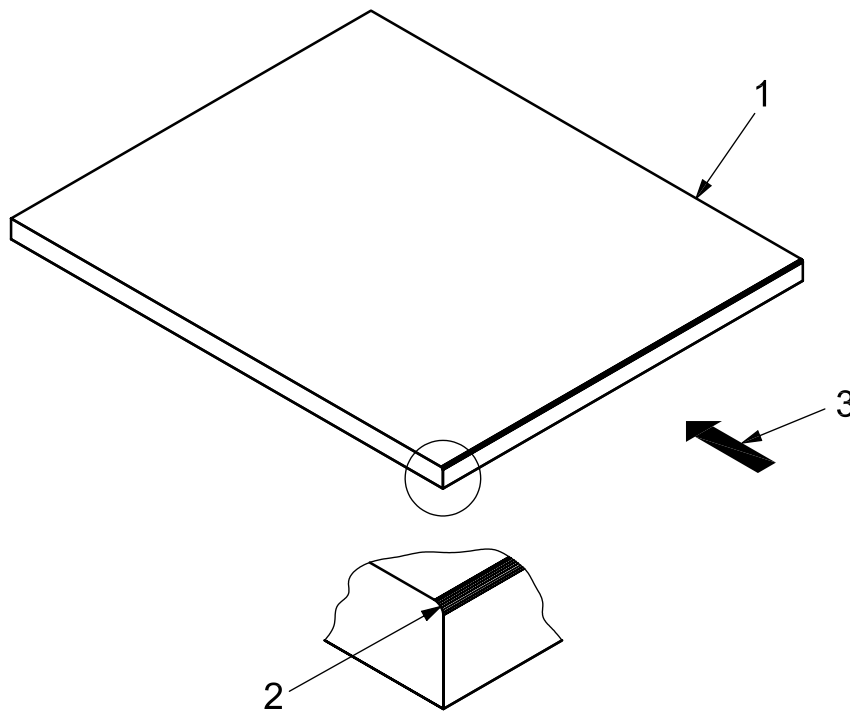

- Key**
- 1 test obstacle
 - 2 upper front edge with radius r
 - 3 direction of approach

Figure 1 — Test obstacle

6 Preparation

Carry out the following preparation sequence.

- a) Fit the largest battery specified by the manufacturer.

- b) Set up the wheelchair as specified in ISO 7176-22.

Load the wheelchair using one of the following:

- 1) a dummy as specified in ISO 7176-11, selected and fitted as specified in ISO 7176-22;
- 2) a human test occupant, combined with a mass evenly distributed over the body support system of the wheelchair such that the total mass is within ${}^{+2}_0$ kg of the mass of the dummy specified in Item 1).

Where a human test occupant is used, it is essential that appropriate precautions be taken to ensure the person's safety.

- c) If practicable, adjust all parts that might come into contact with the obstacle, other than the wheels and devices intended by the manufacturer to facilitate the climbing of obstacles, to prevent them striking the obstacle first.

EXAMPLE Foot supports.

- d) Measure and record the height above the test plane of the lowest part of the foot supports to an accuracy of ± 1 mm.
- e) If practicable, set anti-tipping devices to prevent contact with the test plane and test obstacle during the performance of the tests, otherwise set them at their highest position.

NOTE This does not include removal of anti-tipping devices.

- f) If devices intended by the manufacturer to facilitate the climbing or descending of obstacles are present, follow the manufacturer's instructions to set them in a manner applicable to the test being carried out.

EXAMPLE Kerb climbers.

7 Test procedures

WARNING The following tests can be hazardous. Take appropriate safety precautions to prevent injury to test personnel.

7.1 Carry out the following test sequence.

- a) Set the test obstacle at the starting height specified in 5.2.
- b) Position the wheelchair on the test plane at an angle of incidence to the obstacle of $90^\circ \pm 5^\circ$, with all castors aligned in the trailing position, and with the wheelchair in contact with the obstacle.
- c) With the control device set for full-speed command, drive the wheelchair forwards so that it completely mounts the obstacle with all supporting wheels on the obstacle's upper surface. Immediately release the control device. Record whether any part of the wheelchair, other than the wheels and devices intended by the manufacturer to facilitate the climbing of obstacles, came into contact with the obstacle.
- d) Increase the height of the obstacle by one increment as specified in 5.2 and repeat a) to c).
- e) Repeat d) until the wheelchair can no longer climb the obstacle or exhibits uncontrolled behaviour, such as tipping over or continuing to accelerate after the control device is released.
- f) Record the maximum height of the obstacle that the wheelchair is able to climb.

7.2 Repeat the test procedure specified in 7.1, with a run-up of $500 \text{ mm} \pm 25 \text{ mm}$ measured as the horizontal distance between the obstacle and that part of the wheelchair which will first come into contact with the obstacle (see Figure 2).

7.3 Repeat the test procedure specified in 7.1, but with the wheelchair facing rearwards when climbing the obstacle.

7.4 Repeat the test procedure specified in 7.3, but with a run-up of $500 \text{ mm} \pm 25 \text{ mm}$ measured as the horizontal distance between the obstacle and that part of the wheelchair which will first come into contact with the obstacle (see Figure 2).

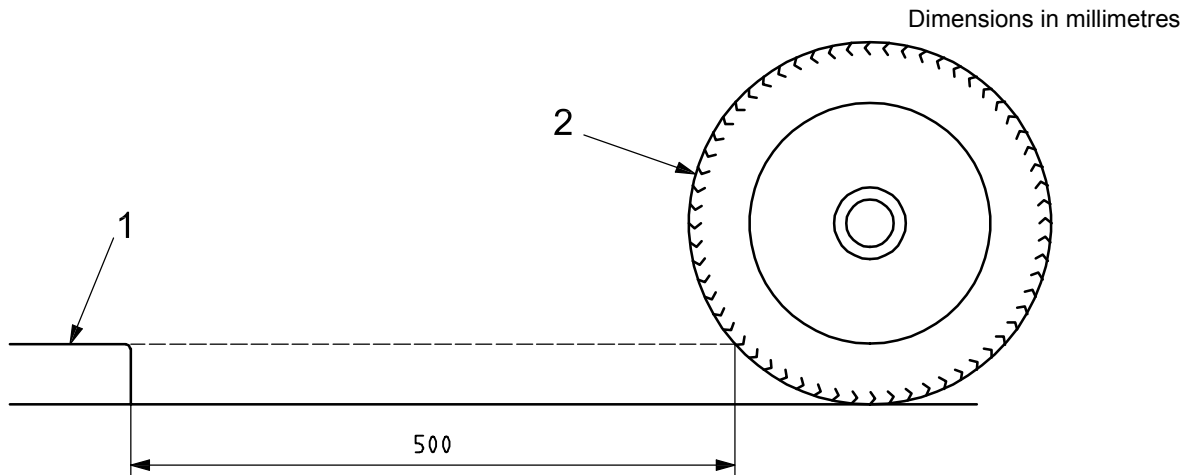

Key

- 1 test obstacle
- 2 part of the wheelchair that will first come into contact with the obstacle

NOTE A wheel is shown as an example.

Figure 2 — Measurement of run-up

7.5 Carry out the following test sequence.

- a) Set the test obstacle at the starting height specified in 5.2.
- b) Position the wheelchair on the obstacle at an angle of incidence to the front edge of $90^\circ \pm 5^\circ$ and with a distance of $500 \text{ mm} \pm 25 \text{ mm}$ between the edge and the point(s) of contact of the nearest supporting wheel(s). Align all castors in the trailing position.
- c) With the control device set for full-speed command, drive the wheelchair forward off the obstacle until all supporting wheels are on the test plane and no part of the wheelchair remains in contact with the obstacle. Immediately release the control device. Record whether any part of the wheelchair, other than the wheels and devices intended by the manufacturer to facilitate the descending of obstacles, came into contact with the obstacle.
- d) Increase the height of the obstacle by one increment as specified in 5.2 and repeat a) to c).
- e) Repeat d) until the wheelchair can no longer descend the obstacle or exhibits uncontrolled behaviour, such as tipping over or continuing to accelerate after the control device is released.
- f) Record the maximum height of the obstacle that the wheelchair is able to descend.

7.6 Repeat the test procedure specified in 7.5, but with the wheelchair facing rearwards when descending the obstacle.

7.7 If any other technique is recommended in the user manual for climbing or descending obstacles, repeat the test procedures specified in 7.1 to 7.4, or 7.5 and 7.6, as applicable, using the manufacturer's recommended technique.

If, in the user manual, the manufacturer recommends settings different from those used in 7.1 to 7.6, follow the manufacturer's recommendations.

EXAMPLE Alternative techniques might include

- setting the wheelchair speed to climb more slowly,
- using a different angle of approach or run-up distance, and
- changing occupant-adjustable or assistant-adjustable controller settings.

7.8 If the wheelchair is equipped with devices intended by the manufacturer to facilitate the climbing and/or descending of obstacles that can be set to be inoperative, set them to be inoperative and repeat the test procedures specified in 7.1 to 7.4, and/or 7.5 and 7.6, as applicable.

7.9 If the wheelchair has more than one mode of operation which can affect the ability of the wheelchair to climb or descend obstacles, repeat the test procedures specified in 7.1 to 7.8 for each operating mode.

EXAMPLE Four-wheel drive mode, indoor mode, outdoor mode, standing mode.

8 Test report

The test report shall contain the following information:

- a) a reference to this part of ISO 7176;
- b) the name and address of the testing institution;
- c) the accreditation of the test laboratory;
- d) the name and address of the manufacturer of the wheelchair;
- e) the date of issue of the test report;
- f) the wheelchair type and any serial and/or batch numbers;
- g) the mass of the dummy or, if a person is used, the total mass of the driver and weights;
- h) details of the set-up of the wheelchair as specified in ISO 7176-22;
- i) a photograph of the wheelchair equipped as during the tests;
- j) the results of the tests specified in 7.1 to 7.9;
- k) whether devices intended by the manufacturer to facilitate the climbing and/or descending of obstacles were fitted;
- l) the height from the ground to the lowest point of the foot supports;
- m) details of any obstacle climbing and/or descending techniques recommended by the manufacturer and used in the tests specified in 7.8;
- n) details of the operating modes used in the tests specified in 7.9.

9 Disclosure

The following results shall be disclosed in the manufacturer's specification sheets in accordance with the format specified in ISO 7176-15:

- a) Maximum obstacle height that can be climbed and descended, reference operationmm;

NOTE This is the minimum of the results recorded in tests 7.1 to 7.6.

- b) Maximum obstacle height that can be climbed and descended, manufacturer's recommended operationmm.

NOTE This is minimum height of the results of tests 7.7 to 7.9.

ICS 11.180.10

Price based on 6 pages