

INTERNATIONAL STANDARD

ISO 7173

First edition
1989-07-01

ISO 7173:1989

Furniture — Chairs and stools — Determination of strength and durability

*Ameublement — Chaises et tabourets — Détermination de la résistance et de la
durabilité*



Reference number
ISO 7173 : 1989 (E)

Foreword

ISO (the International Organization for Standardization) is a worldwide federation of national standards bodies (ISO member bodies). The work of preparing International Standards is normally carried out through ISO technical committees. Each member body interested in a subject for which a technical committee has been established has the right to be represented on that committee. International organizations, governmental and non-governmental, in liaison with ISO, also take part in the work. ISO collaborates closely with the International Electrotechnical Commission (IEC) on all matters of electrotechnical standardization.

Draft International Standards adopted by the technical committees are circulated to the member bodies for approval before their acceptance as International Standards by the ISO Council. They are approved in accordance with ISO procedures requiring at least 75 % approval by the member bodies voting.

International Standard ISO 7173 was prepared by Technical Committee ISO/TC 136, *Furniture*.

© ISO 1989

All rights reserved. No part of this publication may be reproduced or utilized in any form or by any means, electronic or mechanical, including photocopying and microfilm, without permission in writing from the publisher.

International Organization for Standardization
Case postale 56 • CH-1211 Genève 20 • Switzerland

Printed in Switzerland

Contents	Page
0 Introduction	1
1 Scope and field of application	1
2 References	1
3 Definitions	1
4 Test method	2
5 General test requirements	2
6 Test environment and apparatus	2
7 Test procedures	3
7.1 Seat static load test	3
7.2 Back static load test	4
7.3 Arm and wing sideways static load test	4
7.4 Arm downwards static load test	5
7.5 Seat fatigue test	5
7.6 Back fatigue test	5
7.7 Leg forward static load test	5
7.8 Leg sideways static load test	7
7.9 Diagonal base load test	7
7.10 Seat impact test	7
7.11 Back impact test	8
7.12 Arm impact test	8
7.13 Drop test	10
8 Assessment of results	10
9 Test report	11
Annex	
Determination of seat and back loading positions	17

Furniture — Chairs and stools — Determination of strength and durability

0 Introduction

This International Standard is one of a series being prepared on the strength, durability and stability of furniture. The series currently consists of the following:

ISO 7170, *Furniture — Storage units — Determination of strength and durability.*

ISO 7171, *Furniture — Storage units — Determination of stability.*

ISO 7172, *Furniture — Tables — Determination of stability.*

ISO 7173, *Furniture — Chairs and stools — Determination of strength and durability.*

ISO 7174-1, *Furniture — Chairs — Determination of stability — Part 1: Upright chairs and stools.*

ISO 7174-2, *Furniture — Chairs — Determination of stability — Part 2: Chairs with tilting or reclining mechanism.*

ISO 8019, *Furniture — Tables — Determination of strength and durability.*

1 Scope and field of application

This International Standard describes test methods for determining the strength and durability of all types of chairs, easy chairs and stools. Additional tests may be required for certain types of chairs and for chairs for specific fields of use. Such test methods will be described in future International Standards.

NOTE — For the purposes of this International Standard, pouffes are considered as stools.

Assessment of ageing and degradation is not included. The tests are not intended to assess the durability of stuffing materials, upholstery fabrics or foam cushions.

This International Standard does not include tests for reclining or tilted chairs in the reclined or tilted position.

The tests are designed to be applied to an article of furniture that is fully assembled and ready for use.

Forces and dimensions in the tests are applicable to chairs and stools intended for adult persons.

The tests consist of the application, to various parts of the item, of loads or forces simulating normal functional use, as well as misuse that might reasonably be expected to occur.

The tests are designed to evaluate properties without regard to materials, design/construction or manufacturing processes.

The test results are only valid for the article tested. When the test results are intended to be applied to other similar articles, the test specimen should be representative of the production model.

In the case of designs not catered for in the test procedures, the test should be carried out as far as possible as described, and deviations from the test procedure recorded in the test report.

Tests carried out according to this International Standard are intended to demonstrate the ability of the item to give satisfactory service in its intended environment. It should be understood that such tests do not ensure that structural failure will not eventually occur as a result of habitual misuse or after an excessively long period of service, or more than occasional use by persons weighing more than 100 kg.

2 References

ISO 48, *Vulcanized rubbers — Determination of hardness (Hardness between 30 and 85 IRHD).*

ISO 554, *Standard atmospheres for conditioning and/or testing — Specifications.*

ISO 2439, *Polymeric materials, cellular flexible — Determination of hardness (indentation technique).*

3 Definitions

For the purposes of this International Standard, the following definitions apply.

3.1 Strength tests (see 7.1 to 7.4 and 7.7 to 7.13)

3.1.1 static tests: Test consisting of heavy loads being applied a few times to ensure that the furniture has sufficient strength to perform its function under the highest levels of loading that might reasonably be expected to occur.

3.1.2 impact tests: Test to assess the strength of the article under the rapid rates of loading that occasionally occur.

3.2 durability test: Test simulating the repeated movement of components occurring during long-term use and assessing the strength of the article under such conditions (see 7.5 and 7.6).

4 Test method

There are two methods for carrying out the tests.

4.1 For determining the values of strength and durability, testing may be carried out in sequence through the test levels until failure occurs.

4.2 For checking compliance with stated requirements, testing may be carried out by applying directly the appropriate test to the stated requirement.

NOTE — A summary of the tests is given in the table.

5 General test requirements

5.1 Preliminary preparation

Before any of the tests are commenced, the item shall be old enough to ensure that it has developed its full strength. At least four weeks in normal indoor conditions shall have elapsed between manufacture and testing in the case of glued joints in timber and the like. See also clause 8 for preliminary noting of existing defects.

If a standardized atmosphere is to be used for conditioning, it shall have a temperature of 23 ± 2 °C and a relative humidity of (50 ± 5) % according to ISO 554.

The furniture shall be tested as delivered. If of knock-down type, it shall be assembled according to instructions supplied with the furniture. If the furniture can be assembled or combined in different ways, the most adverse combination shall be used for each test. Knock-down fittings shall be tightened before testing.

5.2 Application of forces

The forces in strength tests shall be applied sufficiently slowly to ensure that negligible dynamic load is applied. The forces in durability tests shall be applied sufficiently slowly to ensure that kinetic heating does not occur. It is recommended that the tests are carried out at a maximum rate of six cycles per minute.

5.3 Loading

The severity of the loading may be varied by the number of applications or the magnitude of the loads applied. For guidance, five test levels are given in the table based on the intended end-use of the article.

5.4 Test conditions

The tests may be applied by any suitable device because results are dependent only upon correctly applied loads and not upon the apparatus, except in the case of impact tests where the apparatus described in 6.8 and 6.9 shall be used. The seat loading apparatus should be such as not to restrain the chair from tilting over nor hinder horizontal movement of the chair when the back load is applied.

For tolerances, unless otherwise stated all forces shall have an accuracy of ± 5 %, all masses an accuracy of $\pm 0,5$ % and all dimensions an accuracy of $\pm 0,5$ mm.

5.5 Sequence of testing

All applicable tests shall be carried out on the same chair or stool and in the order listed.

6 Test environment and apparatus

6.1 Floor surface, horizontal, flat. For the drop test (7.13) a rubber mat 2 mm thick, with hardness 97 IRHD according to ISO 48, on a concrete floor.

6.2 Stops, to prevent the article from sliding but not tilting, no higher than 12 mm except in cases where the design of the item necessitates the use of higher stops, in which case the lowest that will prevent the item from moving shall be used.

6.3 Seat loading pad, naturalistically shaped rigid indent (see figure 13) with a hard, smooth surface.

NOTE — The shape is not defined in detail but will be available from national testing authorities.

6.4 Smaller seat loading pad, rigid circular object 200 mm in diameter the face of which has a convex spherical curvature of 300 mm radius with a 12 mm front edge radius (see figure 14).

6.5 Back loading pad, rigid rectangular object 200 mm high and 250 mm wide the face of which is curved across the width of the pad with a convex cylindrical curvature of 450 mm radius and with a 12 mm radius on all front edges (see figure 15).

6.6 Local loading pad (i.e. for arm and leg loading test), rigid cylindrical object 100 mm in diameter, with a flat face and a 12 mm radius on the front edge.

NOTE — All loading pads should be capable of pivoting in relation to the direction of the applied force.

6.7 Foam for facing loading pads, 25 mm thick layer of polyether foam with a hardness index when measured according to ISO 2439, method A, of 135/660 N and a density of 27

to 30 kg/m^3 . Alternatively a layer of this foam may be positioned between the loading pad and the test structure.

6.8 Seat impacter (see figure 16)

6.8.1 Circular body, approximately 200 mm in diameter separated from the striking surface by helical compression springs and free to move relative to it on a line perpendicular to the plane of the central area of the striking surface.

The body and associated parts minus the springs shall have a mass of $17 \pm 0,1 \text{ kg}$ and the whole apparatus, including mass, springs and striking surface, shall have a mass of $25 \pm 0,1 \text{ kg}$.

6.8.2 Springs, which shall be such that the combined spring system has a nominal spring rate of $0,69 \pm 0,1 \text{ kg/mm}$ and the total friction resistance of the moving parts is between 0,025 kg and 0,045 kg.

The spring system shall be compressed to an initial load of $104 \pm 0,5 \text{ kg}$ (measured statically) and the amount of spring compression movement available from the initial compression point to the point where the springs become fully closed shall be not less than 60 mm.

6.8.3 Striking surface, approximately flat leather pad containing fine dry sand.

6.9 Impact hammer, cylindrical object having a mass of 6,5 kg, supported from a pivot by a steel tube of 38 mm in diameter and with a wall thickness of 1,6 mm. The distance

between the pivot and the centre of gravity of the striker is 1 m. The pendulum arm is pivoted by a low friction bearing. (See figure 17.)

6.10 Chair loading position template, as described in the annex.

7 Test procedures

7.1 Seat static load test

Position the seat loading pad (6.3) to conform to the seat plane, firstly at the seat loading position determined by the chair loading position template (figures 18 to 20), and subsequently at 100 mm back from the front edge of the seat. Apply the appropriate downward force (see figure 1) specified in the table, 10 times. During each application, maintain the force for at least 10 s.

Assess defects according to clause 8.

When it is not clear which of several positions of the loading pad is likely to cause failure, for example when testing pedestal and cantilever chairs, subject each of the positions to 10 applications of the force specified above.

In the case of stools, apply the load along the fore and aft centre line of the seat at the seat loading position for stools determined by the chair loading position template, if necessary using the smaller seat loading pad (6.4).

If required, repeat the test on footrails or footrests at the appropriate test level.

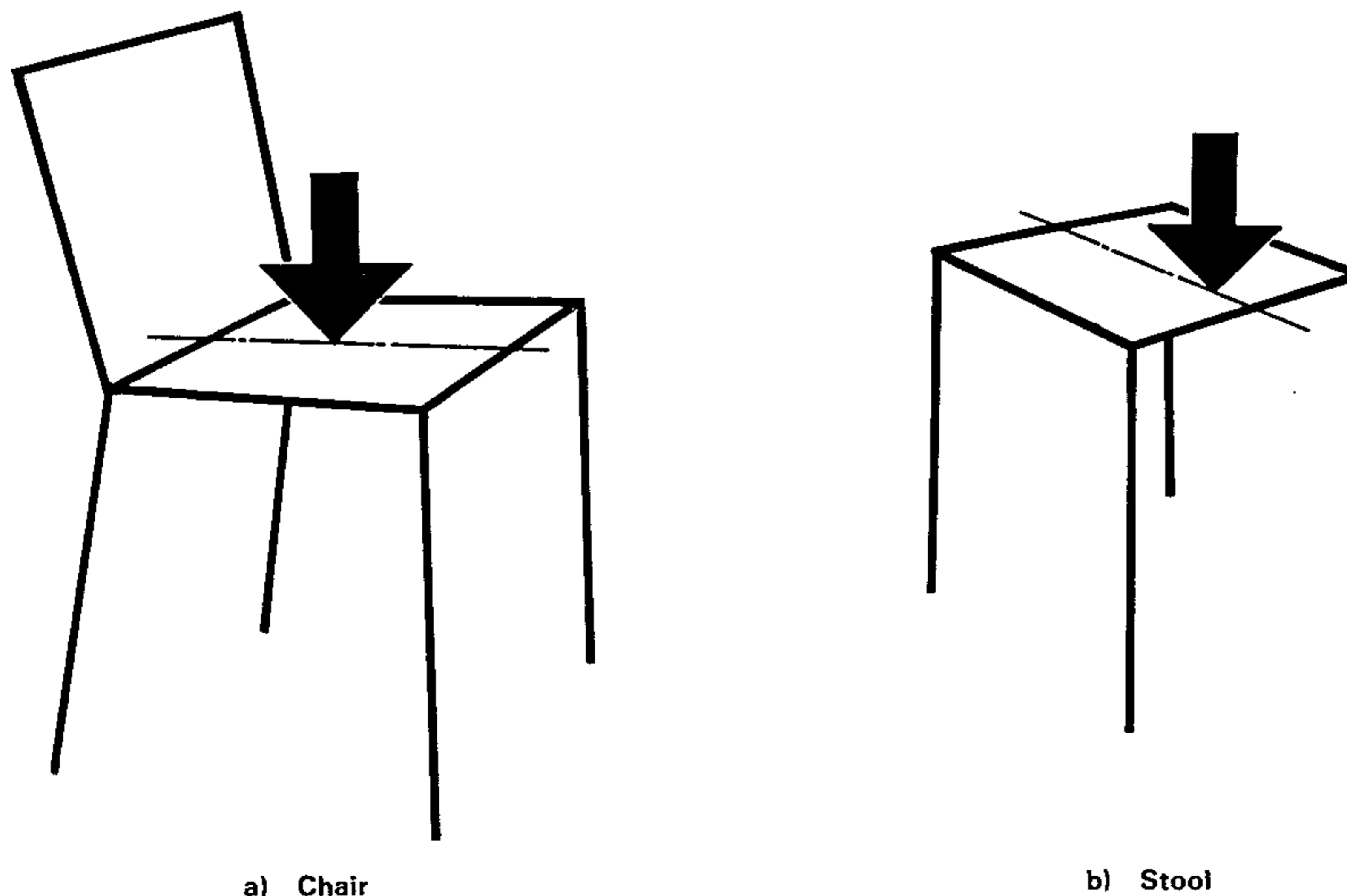

Figure 1 — Seat static load test

7.2 Back static load test

Position the centre of the back loading pad (6.5) either at the back loading position as specified by the chair loading position template (see figure 20) or at 100 mm below the top of the back, whichever is the lower. Prevent the chair from moving rearwards by placing stops behind the rear feet or castors.

Apply the test load of the appropriate magnitude specified in the table perpendicular to the back when under load.

Conduct the test by the application of the load 10 times, with the balancing seat load specified in the table applied at the seat loading position (see the annex). During each application, maintain the load for at least 10 s.

The back static force shall be at least 410 N. If the chair tends to overbalance at this force, the force applied to the seat shall be increased until this tendency ceases.

When this test is applied to a chair fitted with a spring rocking action base that has a tension adjustment, increase the tension so that the least possible rocking movement is obtained during the test.

NOTES

1 If it is not possible to apply the back load at the back loading position due to the construction of the chair, e.g. if the back is constructed of cross-members positioned above and/or below the back loading position, a suitable panel may be used to spread the load over the back cross-members so long as this surface does not overlap the side upright members.

2 If the chair is fitted with a tilting mechanism, this should be adjusted so that the back of the chair is tilted at $15 \pm 5^\circ$ back from the vertical.

On the first and the tenth application of the back static load, measure the relative deflection of the back and calculate d/h , as illustrated in figure 2, h being the distance from the seat surface to the top of the back and d being the deflection of the top of the back.

When this test is applied to a stool without a backrest, or with a very low back, apply the backward force horizontally to the front edge of the seat. Regardless of the shape of the seat for stools with rectangular underframes, apply the force perpendicular to each of two adjacent sides in turn, half the number of applications of the force being applied to each side. For stools with triangular underframes, apply the force along each of any two median lines in turn.

NOTE — Since one position of the seat loading pad in the seat static load test is the same as that specified for the back static load test, it is normally convenient to perform these two tests together as a combined seat and back static load test. In this case, the seat load should be applied first and then maintained while the back load is applied.

7.3 Arm and wing sideways static load test

Apply a pair of outward forces of the appropriate magnitude specified in the table between the arms of the chair at the point along the arms most likely to cause failure (see figure 3). Apply the forces 10 times, using the local loading pad (6.6). During each application, maintain the load for at least 10 s. If the chair has wings, i.e. two side pieces at the top of an armchair against which the head may be rested, repeat the test on both wings with the appropriate force specified in the table.

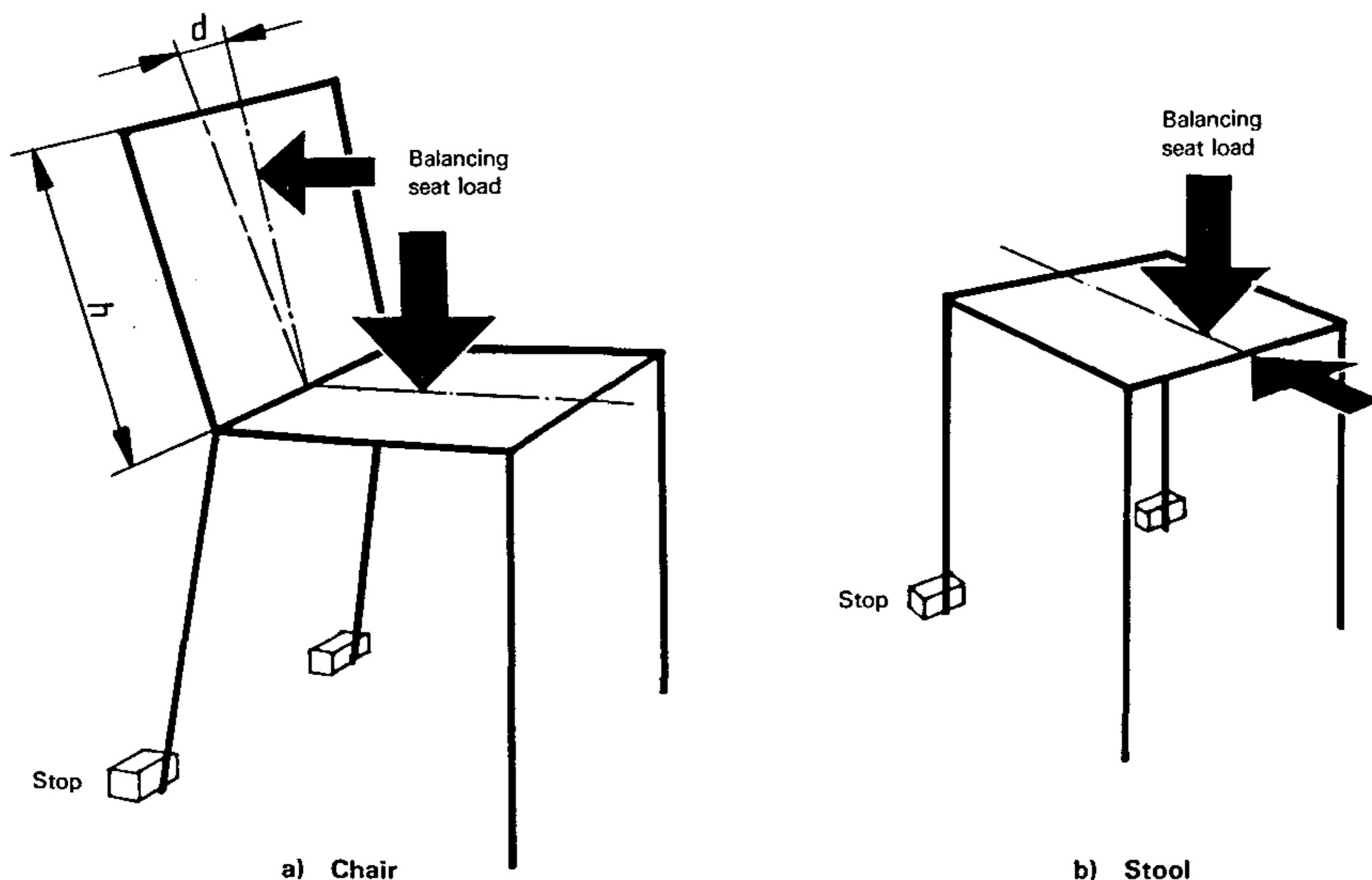

Figure 2 — Back static load test

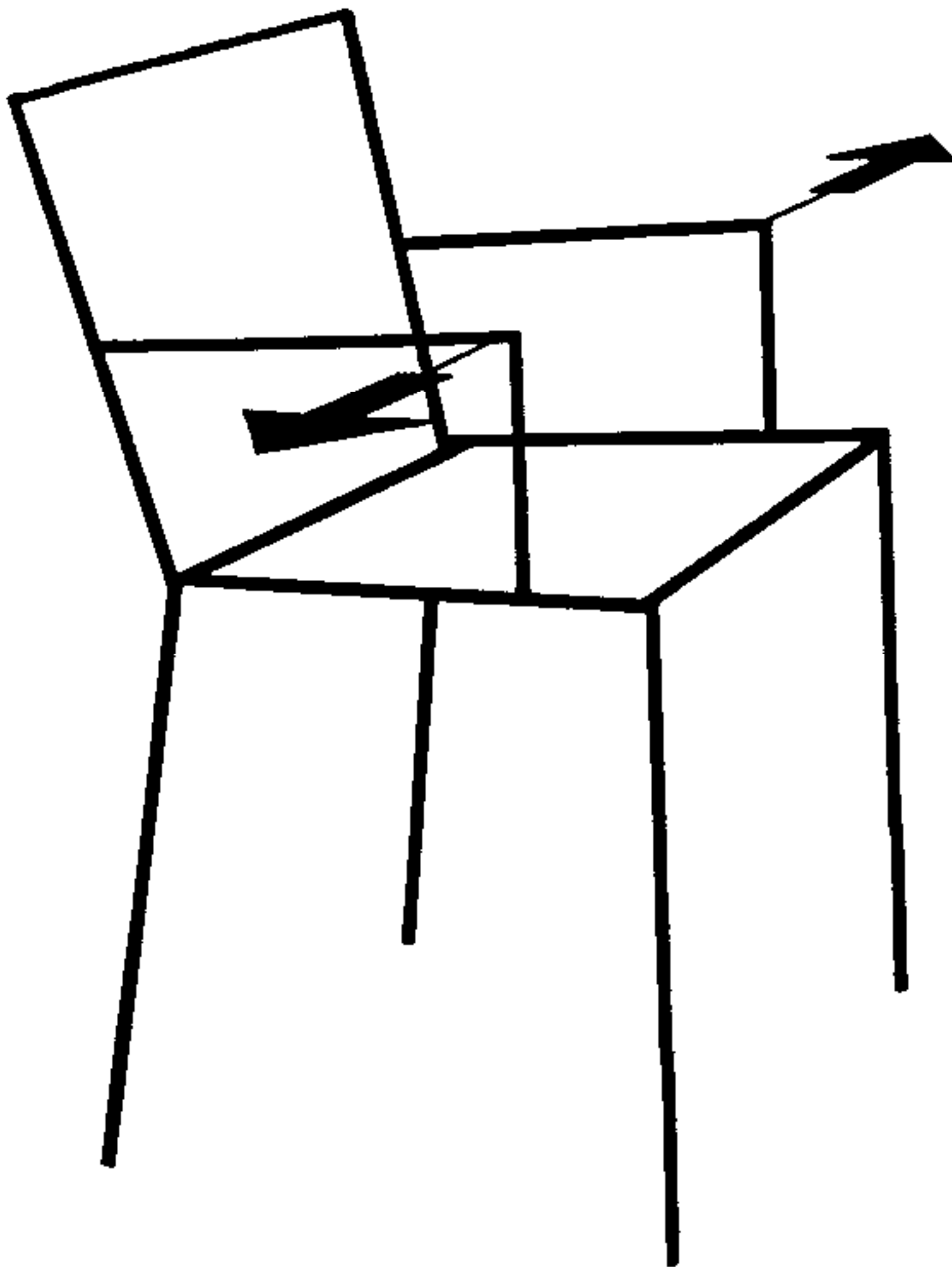

Figure 3 — Arm and wing sideways static load test

7.4 Arm downwards static load test

Apply a vertical force of the appropriate magnitude specified in the table 10 times at the point along the arms most likely to cause failure. (See figure 4.)

Apply the load through the smaller seat loading pad (6.4) and during each application, maintain the load for at least 10 s.

If the chair overbalances, apply a balancing load large enough to prevent the chair from overbalancing when the full force is applied, on the side of the seat opposite to that on which the full force is applied.

NOTE — The arm sideways static load test can be combined with the arm downwards static load test by combining the horizontal and vertical loads (for each level) into a diagonal load, this being the resultant of the two loads.

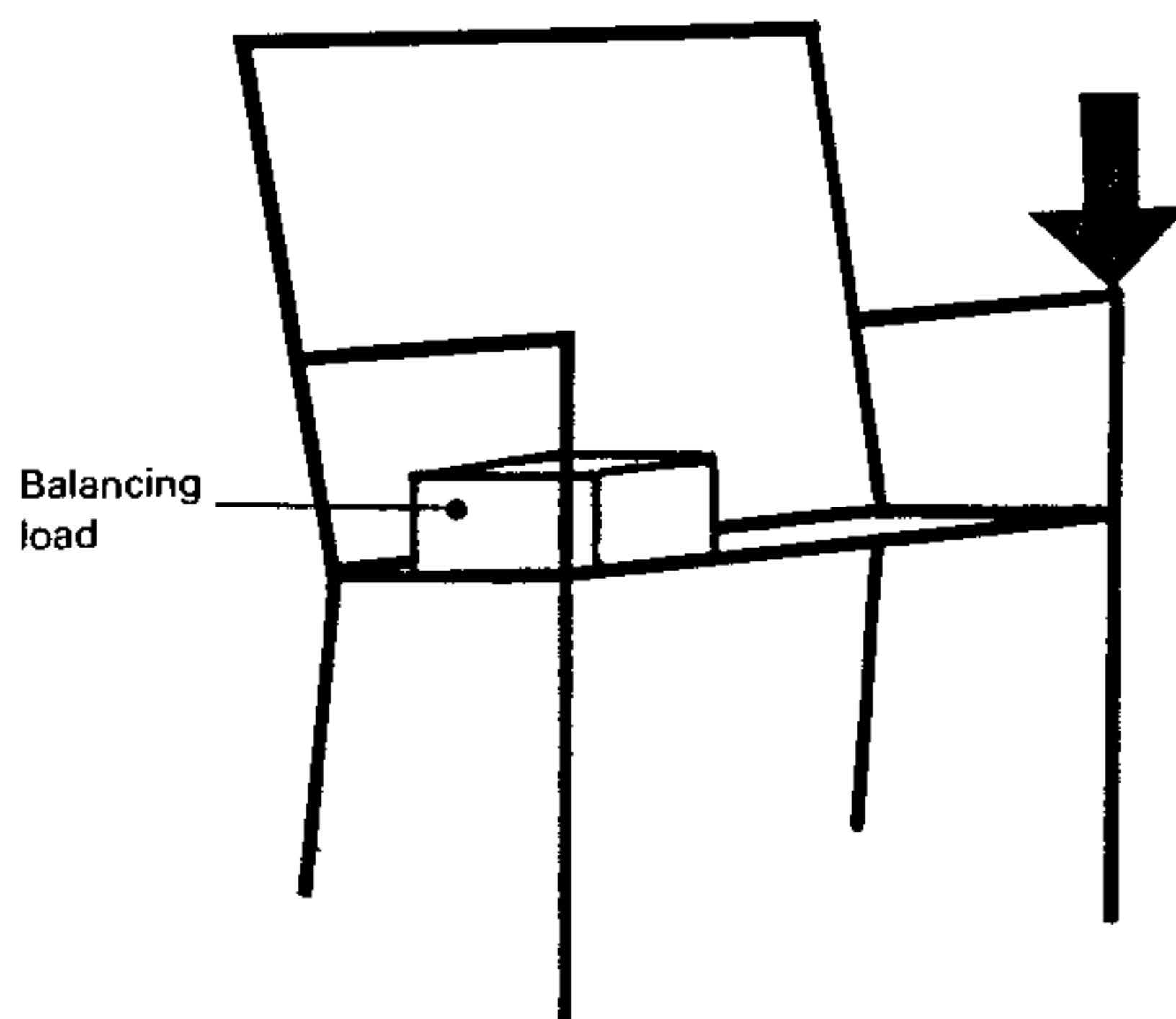

Figure 4 — Arm downwards static load test

7.5 Seat fatigue test

Apply the force of 950 N by means of the seat loading pad (6.3) with the centre of the loading pad positioned at the seat loading position determined as in the annex. Apply the force for the appropriate number of times specified in the table at a rate not exceeding 40 cycles per minute.

Measure the lowest position of the pad during the first and the last cycle of the test. Record the difference of the two values obtained as the deflection of the seat during the test.

If required, repeat the test on footrails or footrests at the appropriate test level.

7.6 Back fatigue test

Position the centre of the back loading pad (6.5) either at the back loading position determined as in the annex, or at 100 mm below the top of the back, whichever is the lower. Prevent the chair from moving rearwards by placing stops behind the rear feet or castors. Conduct the test by the repeated application of a force of 330 N, or if the chair overbalances, of such lesser force as to prevent rearwards overbalancing. Carry out the test at a rate not exceeding 40 cycles per minute for the appropriate number of applications specified in the table. During each cycle apply a force of 950 N to the seat (see figure 6).

When this test is applied to a chair fitted with a spring rocking action base that has a tension adjustment, adjust the tension to the middle of its range of adjustment.

When this test is applied to a stool without a backrest, or with a very low back, apply the backward force horizontally to the front edge of the seat. Test stools with four legs on which the seat surface is not symmetrical both with the seat major dimensions sideways, and with the major dimensions fore and aft for half the number of applications of the force in each of the two directions. Test stools with three legs along two of the principle axes of the three feet.

NOTE — Because the number of cycles and the seat load are common to both the seat and back fatigue tests it is normally convenient to perform these two tests together as a combined seat and back fatigue test. In this case, the seat load should be applied first and then maintained while the back load is applied.

7.7 Leg forward static load test

Restrain the front feet of the chair or stool from movement whilst applying a horizontal force centrally to the rear of the chair at seat level in a forward direction, by means of the local loading pad (6.6). For stools with only three legs, one foot on the fore and aft centre line and one other foot should be restrained. The maximum force shall be the appropriate force specified in the table.

Apply the appropriate seat load specified in the table at the seat loading position specified by the chair loading position template (see figure 20). If the chair or stool tends to overbalance, reduce the load to a magnitude that just prevents forward overbalancing, and record the actual force used. [See figure 7 a.)]

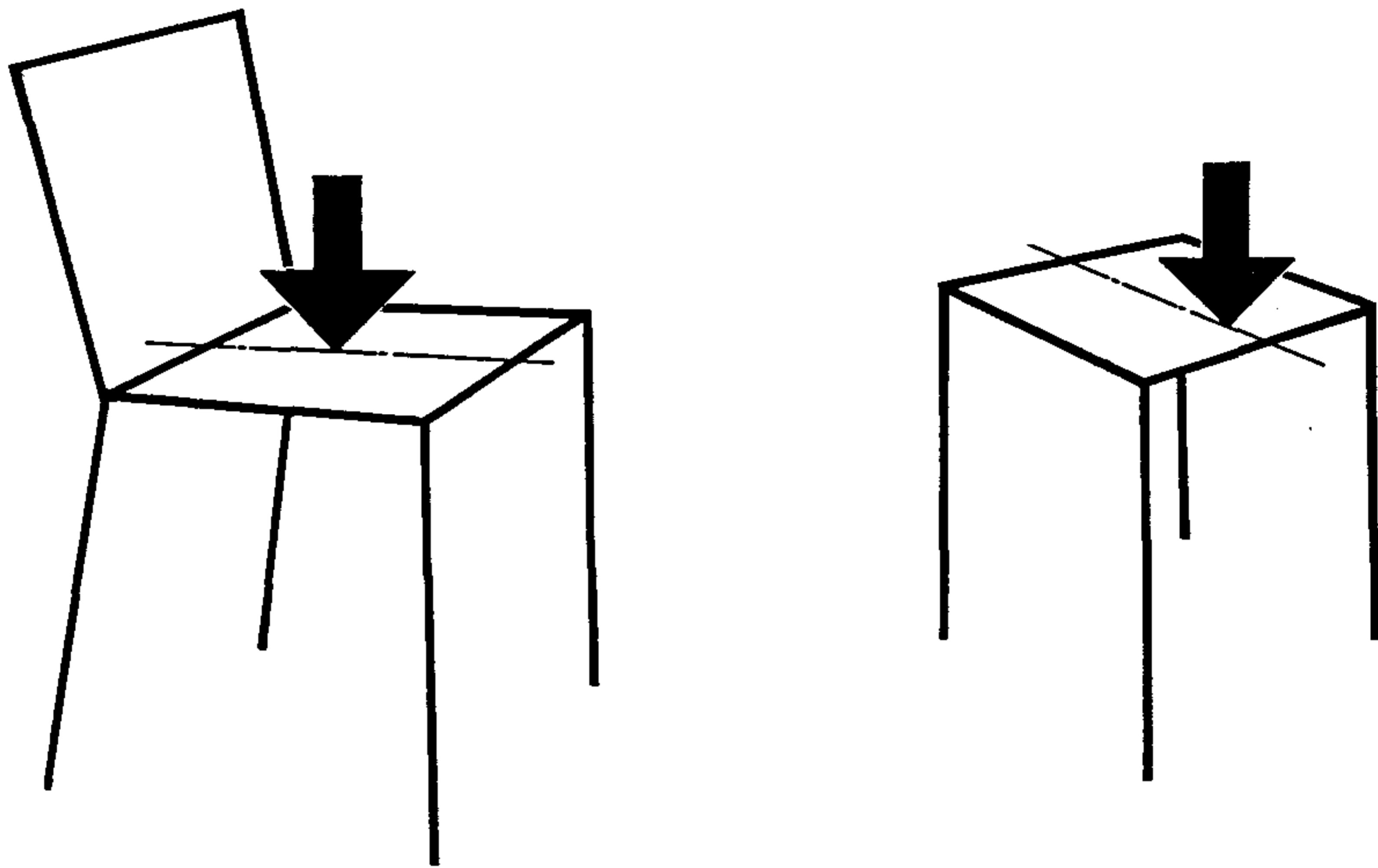

Figure 5 — Seat fatigue test

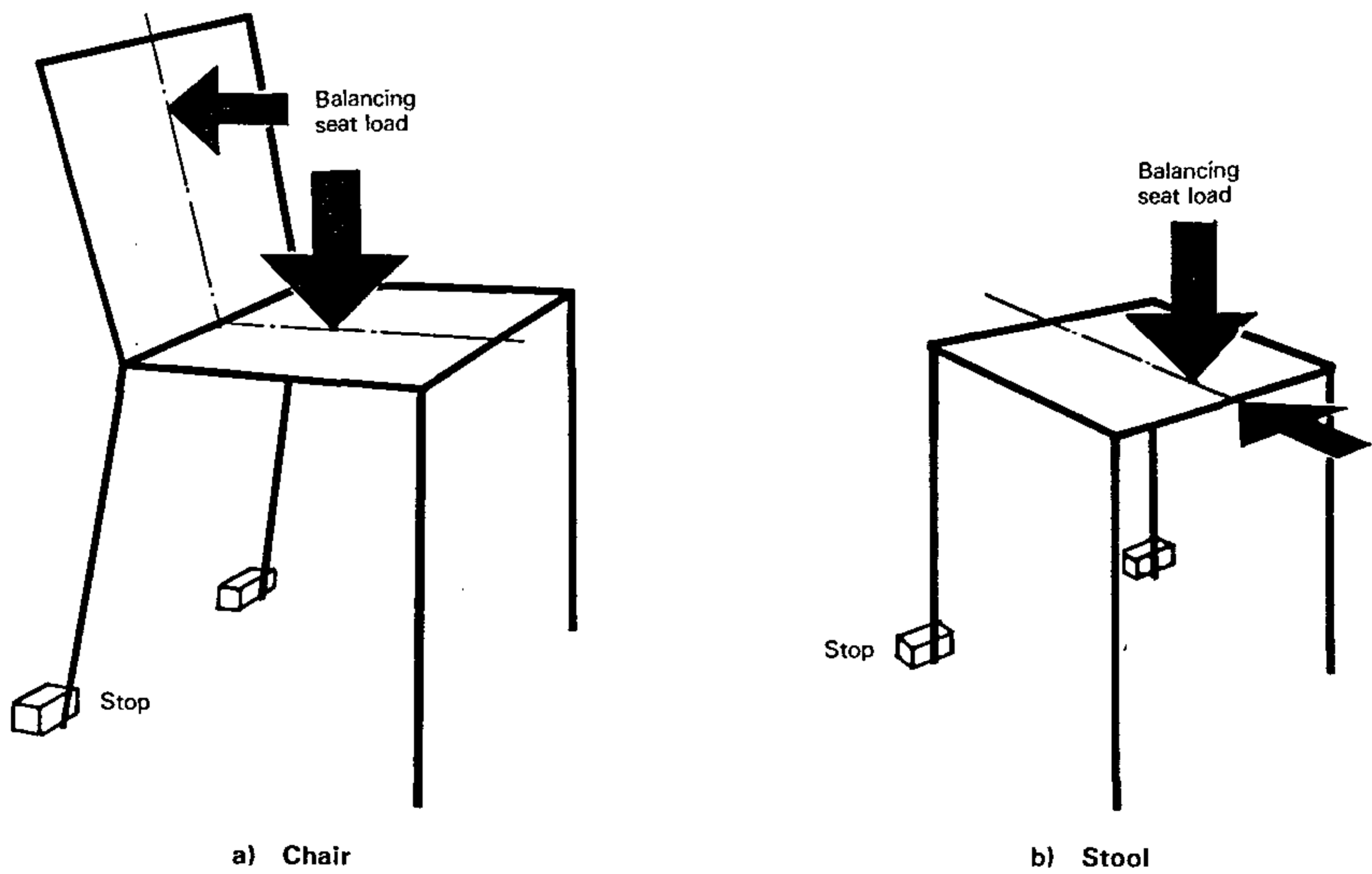

Figure 6 — Back fatigue test

Apply the forward leg load 10 times, and during each application, maintain the load for at least 10 s.

7.8 Leg sideways static load test

Carry out this test in the same manner as the leg forward static loading test except restrain a pair of front and rear feet from movement whilst applying a horizontal force centrally to the side of the article at seat level, in a sideways direction towards the restraining feet. Apply the appropriate vertical seat load specified in the table at a suitable position across the seat but not more than 150 mm from the unloaded edge of the seat. Apply the horizontal force 10 times, and during each application maintain the load for at least 10 s. The maximum force shall be that specified in the table. [See figure 7 b).]

If the article tends to overbalance with the vertical seat load in its furthestmost position from the unloaded edge, reduce the horizontal seat loading force to a magnitude that just prevents sideways overbalancing, and record the actual force used.

NOTE — Leg tests are applicable to chairs and stools with legs or pedestals. There are no rearward leg loading tests because proof of durability when subjected to them will have been demonstrated in the back static loading test (7.2).

Similarly, the leg tests need not be applied to stools without backrests and without an obvious front and rear, because proof of the performance of the stool when subjected to them will have been demonstrated in the back static loading test (7.2).

For stools with backrests and those with shaped seats so that the front and rear of the stool are obvious, the leg tests should be applied as for chairs. Where such a stool has only three legs, one foot on the fore and aft centre line of the stool and one other foot should be provided with stops in the sideways loading test.

Chairs without legs or pedestals should be subjected to the diagonal base load test (see 7.9).

7.9 Diagonal base load test

The diagonal base test shall be applied to chairs or stools without pedestals or legs. Chairs with pedestals or legs shall be subjected to the leg static load tests (see 7.7 and 7.8).

Apply simultaneously two opposing forces of the magnitudes specified in the table to one pair of diagonally opposite corners of the article. Apply these forces as near as possible to the lowest point, in an inward direction 10 times, and during each application maintain the load for at least 10 s. (See figure 8.)

7.10 Seat impact test

Place a piece of foam (6.7) on the seat.

Allow the seat impacter (see 6.8 and figure 16) to fall freely from the appropriate height specified in the table onto the seat loading position as specified by the chair loading position

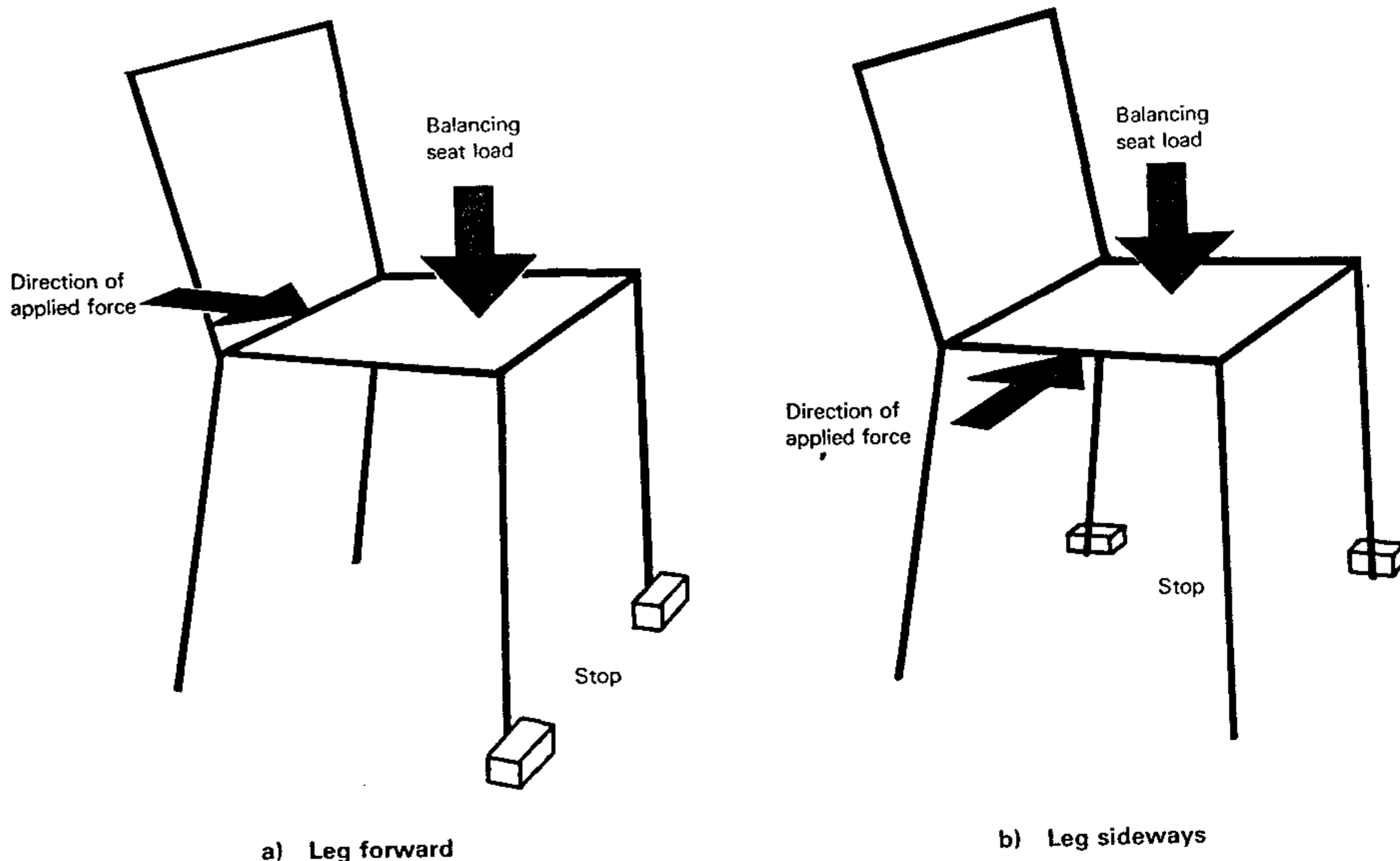

Figure 7 — Leg static load test

template (see the annex and figure 9). Repeat this test 10 times. Repeat at any other position considered likely to cause failure.

In the case of soft upholstery, calculate the height of fall when the seat is loaded with a mass of 2 kg working via the smaller seat loading pad (6.4).

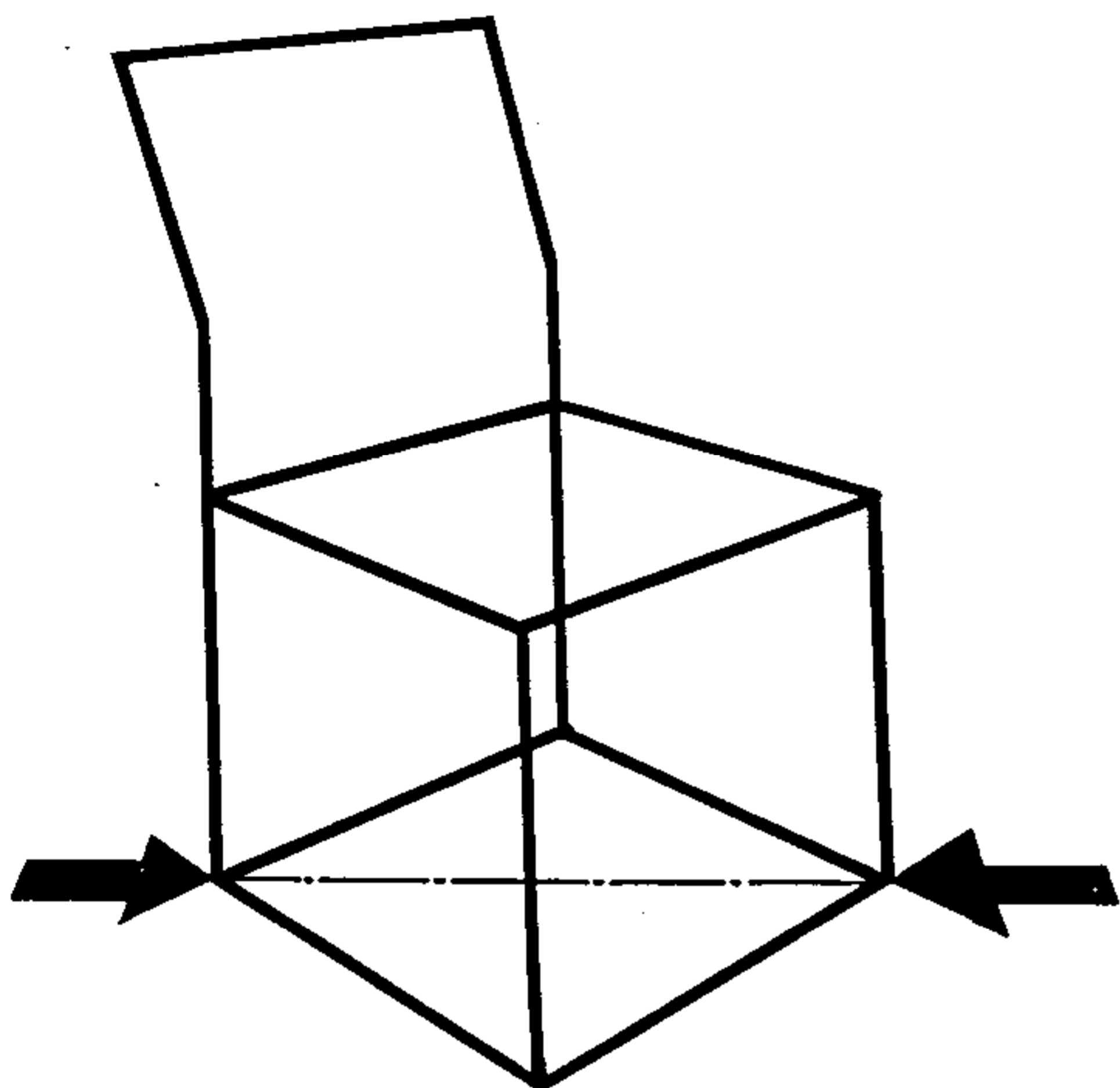

Figure 8 — Diagonal base load test — Directions of forces

7.11 Back impact test

Carry out the test with the impact hammer (6.9).

Place the chair or stool with its front feet prevented by stops from moving forward.

Strike the outside of the chairback top at its centre, or, when there is no back, the centre of the seat rear edge horizontally with the impact hammer falling from a height or angle as specified in the table. Repeat the procedure 10 times.

If a stool has no easily determined rear edge, apply the test in the direction most likely to cause the stool to tip over.

If the chair has wings, rearrange the position of the chair and repeat the test with the striker hitting the outside of the top of one wing at right angles to the surface and in the position most likely to cause failure. Restrain the legs of the opposite side.

7.12 Arm impact test

Carry out the test in the same manner as the back impact test (7.11) except that the impact should be applied in an inward direction to the outside face of one arm at the position most likely to cause a failure. (See figure 11.)

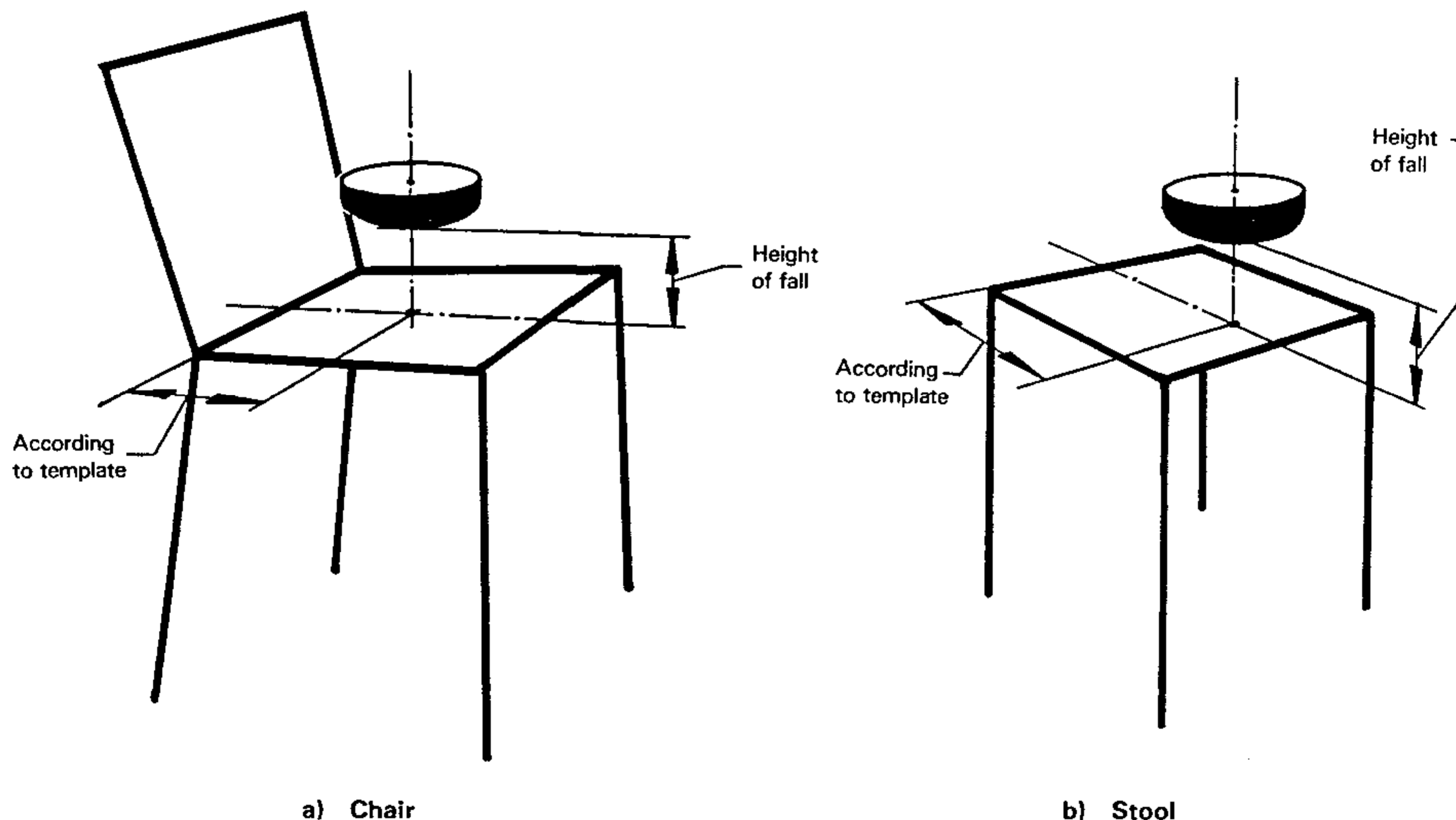

a) Chair

b) Stool

Figure 9 — Seat impact test

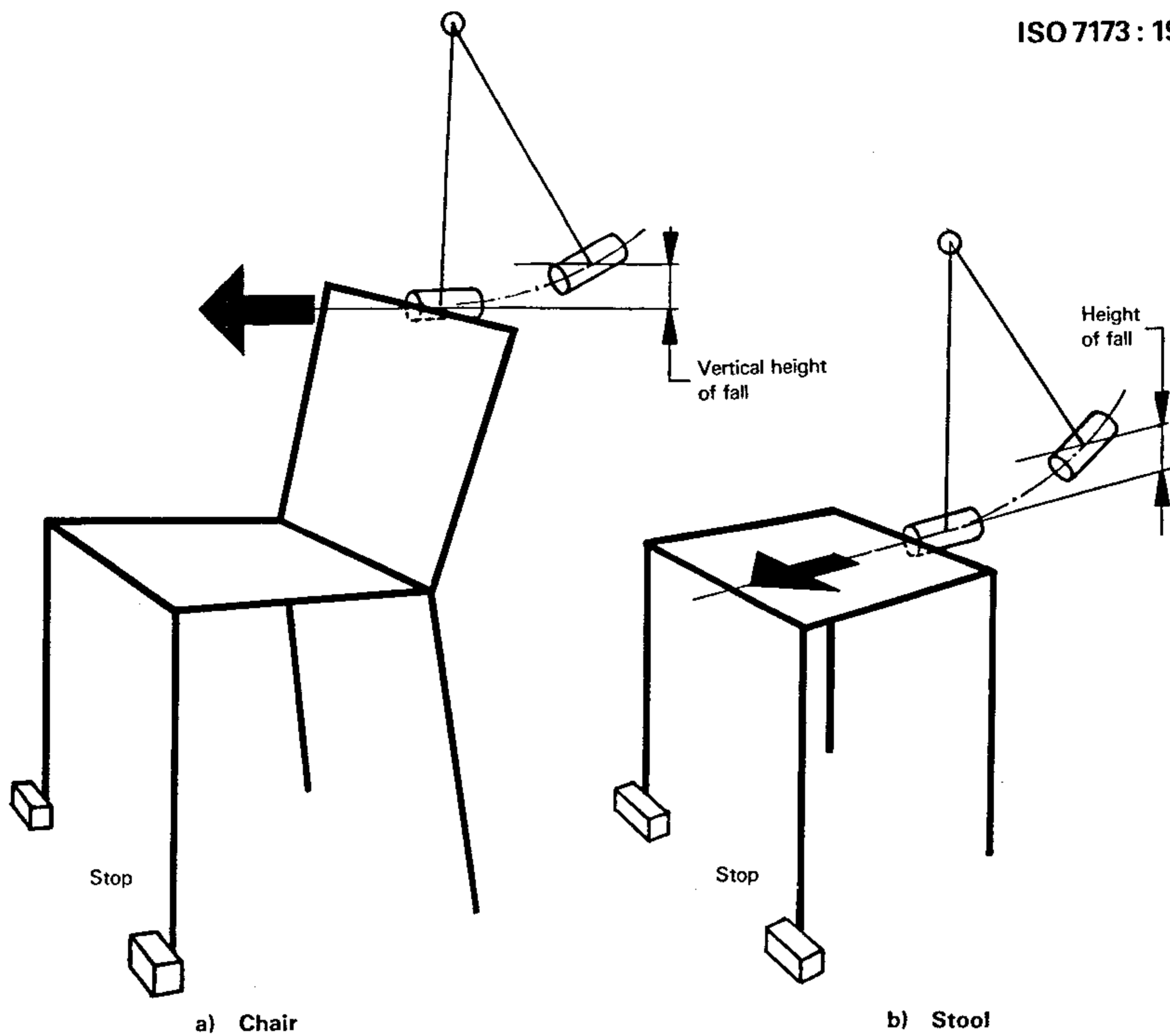

Figure 10 – Back impact test

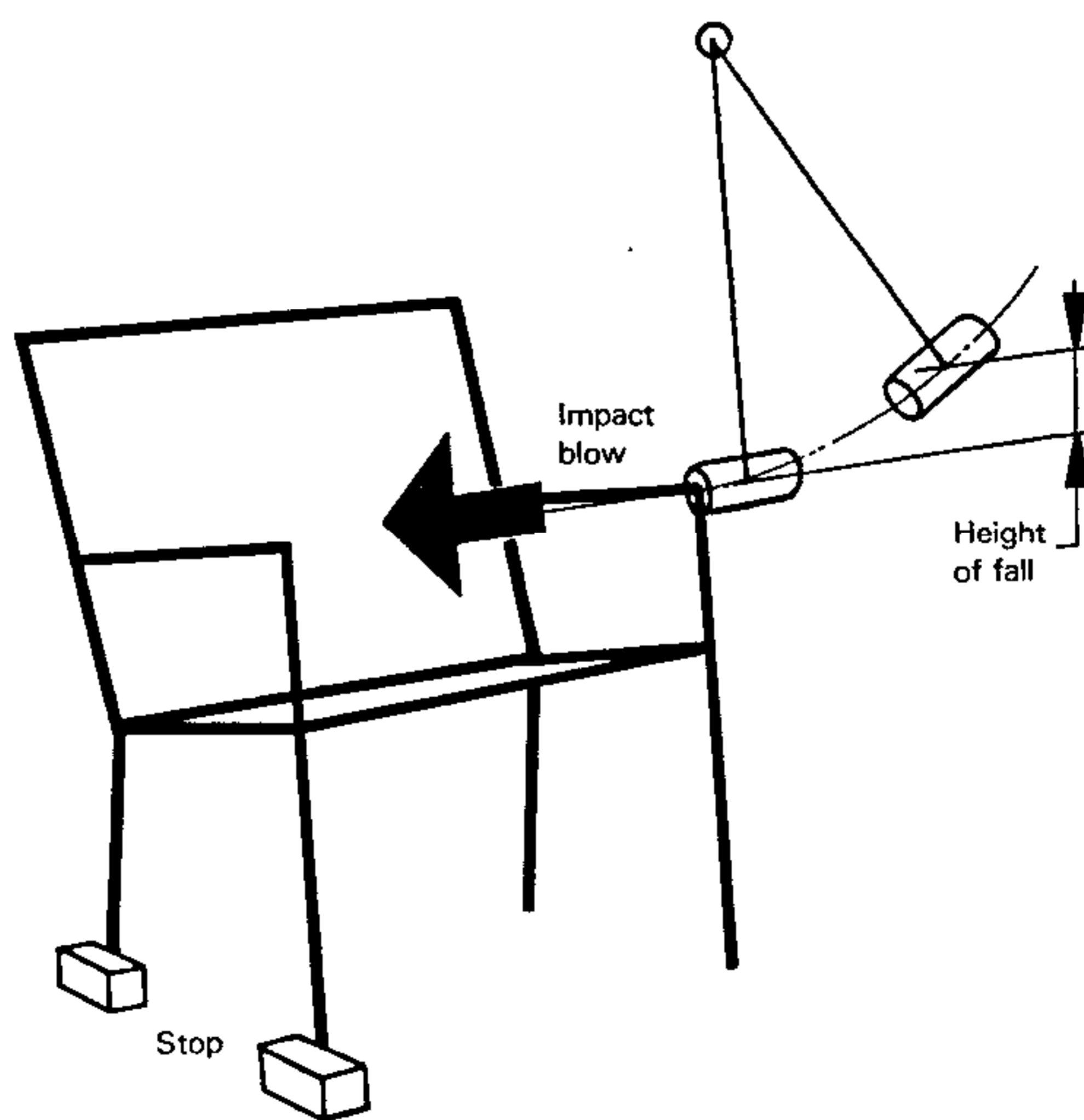

Figure 11 – Arm impact test

7.13 Drop test

Support the chair so that, at impact on one foot, the line joining that foot to the foot diagonally opposite is inclined at 10° to the horizontal, whilst the line joining the remaining feet is horizontal. In the case of three-legged stools, support the stool so that the line joining two feet shall be horizontal and the line from the third foot, i.e. the one receiving impact, to the mid-point of the line is inclined at 10° to the horizontal. (See figure 12.)

Lift up the article to the appropriate height specified in the table for the type of leg or pedestal fitted to the article. Drop the article 10 times onto a front leg, and 10 times onto a rear leg or in the case of three-legged articles, onto two legs in turn, onto the standard floor (6.1).

NOTES

1 This test may be carried out by lifting the article by three cords that are adjusted in length with the article standing in the correct orientation on a plane inclined at 10° to the horizontal.

2 Stacking chairs and stools are more likely to be dropped than other types of seating. Chairs should be subjected to drop tests at whichever height is appropriate.

8 Assessment of results

Immediately before commencement of testing, inspect each chair or stool thoroughly. Note any defects in the members, joints or attachments so that they are not attributed to the effect of the tests when the tests have been completed. Carry out a dimensional check of the article in any case where it can be expected to suffer deformation as a result of testing.

Immediately after completion of the tests, reinspect the chair or stool thoroughly. Note any apparent defects and determine any changes that have taken place since the initial inspection including:

- a) the fracture or cracking of any member, component or joint, including seat suspensions, castors, and structural shells;

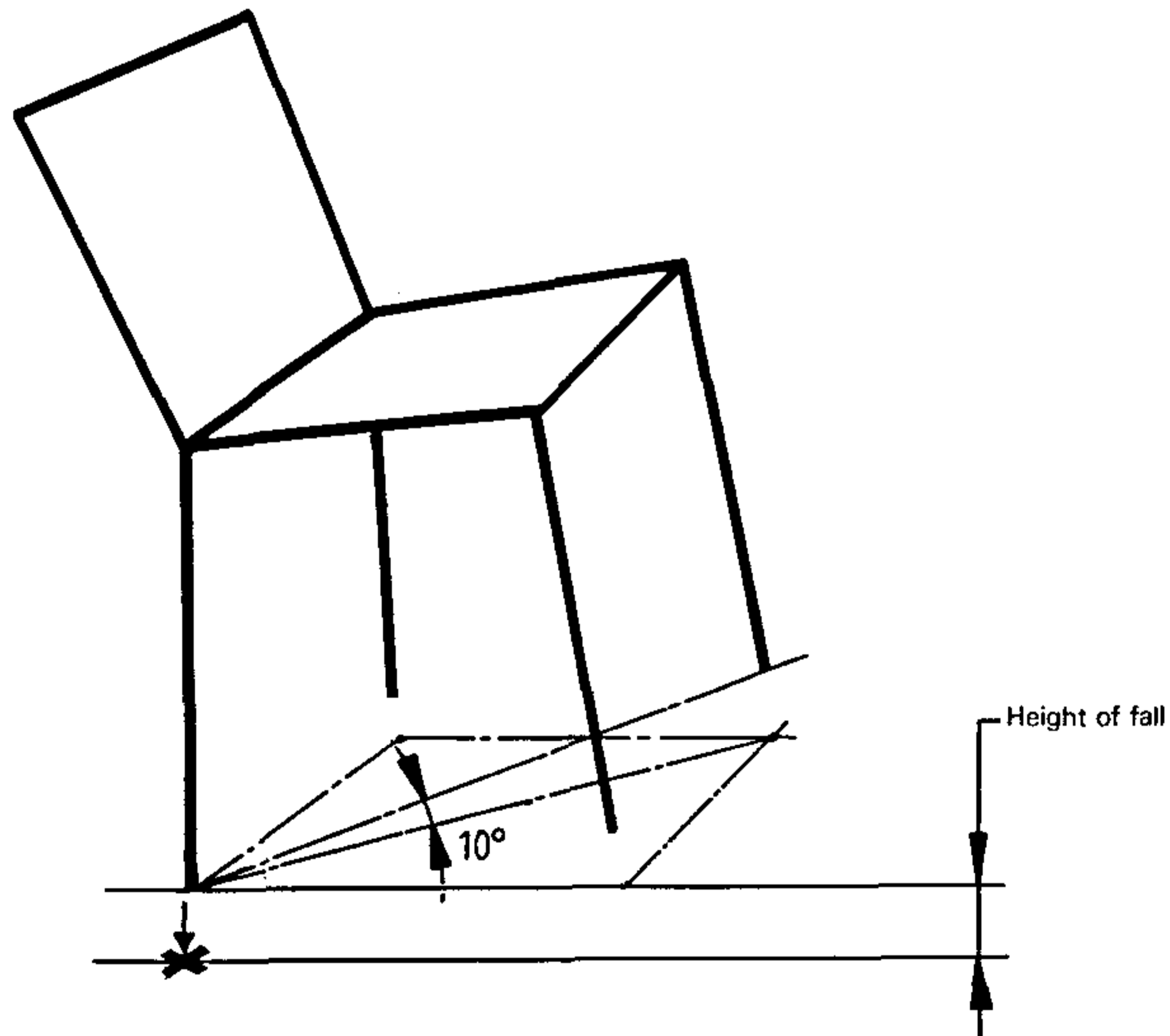

Figure 12 — Drop test

b) the loosening, shown to be permanent by hand pressure applied to suitable members, or joints intended to be rigid;

c) the loosening of the underframe or base inserts moulded into a structural shell relative to the shell surface, shown to be permanent by means of hand pressure applied to the underframe or base;

d) the free movement in the back, arms, legs or other components of the article greater than that noted in the initial inspection;

e) the deformation of any part of the article or any cracks which will adversely affect its appearance;

f) the impairment of the operation of any mechanical part (including any significant change in the seat height during any phase of the seat height adjustment tests);

g) clearly audible noise developed during testing.

Pass and fail criteria are to be established in requirement specifications.

9 Test report

The test report shall include at least the following information :

a) a reference to this International Standard;

b) the piece of furniture tested (relevant data) and details of any defects before testing the moisture content, where appropriate;

c) the test results according to clauses 7 and 8 (including the test level used);

d) details of any deviations from this International Standard;

e) the name and address of the test facility;

f) the date of test.

Dimensions in millimetres

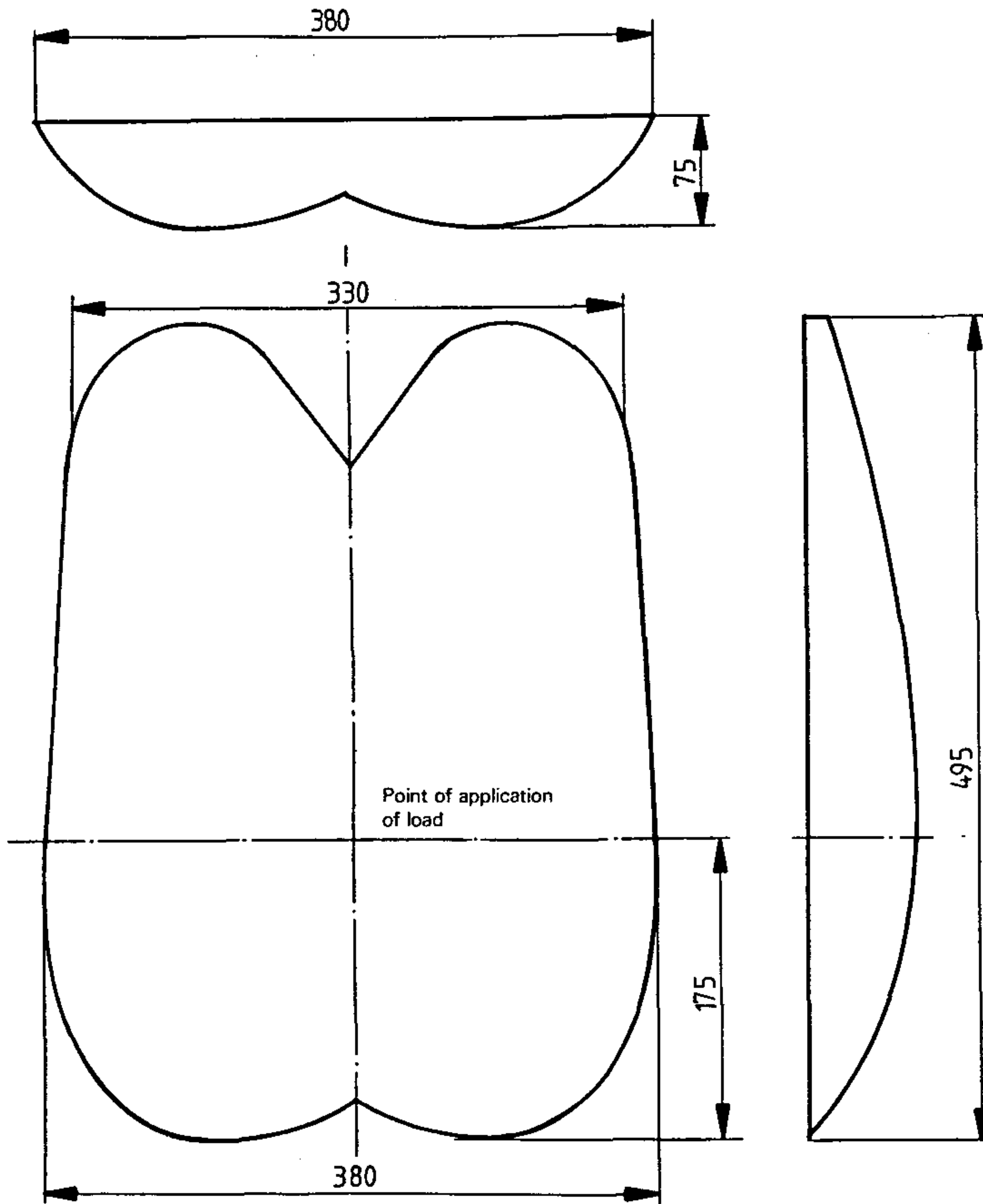

a) Plan

b) Side elevation

Figure 13 — Details of the naturalistically shaped standard seat loading pad

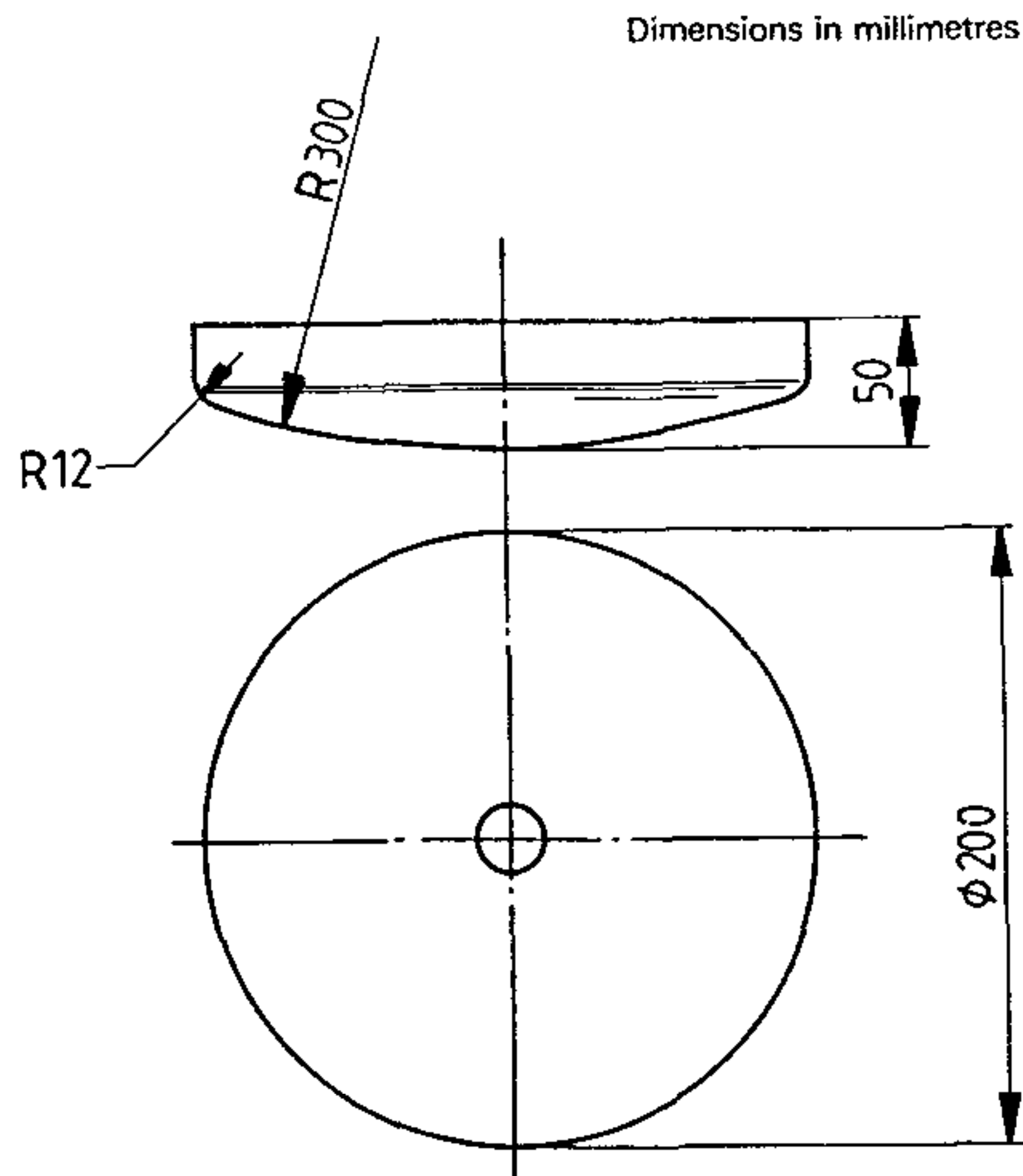

Figure 14 – Details of the smaller seat loading pad

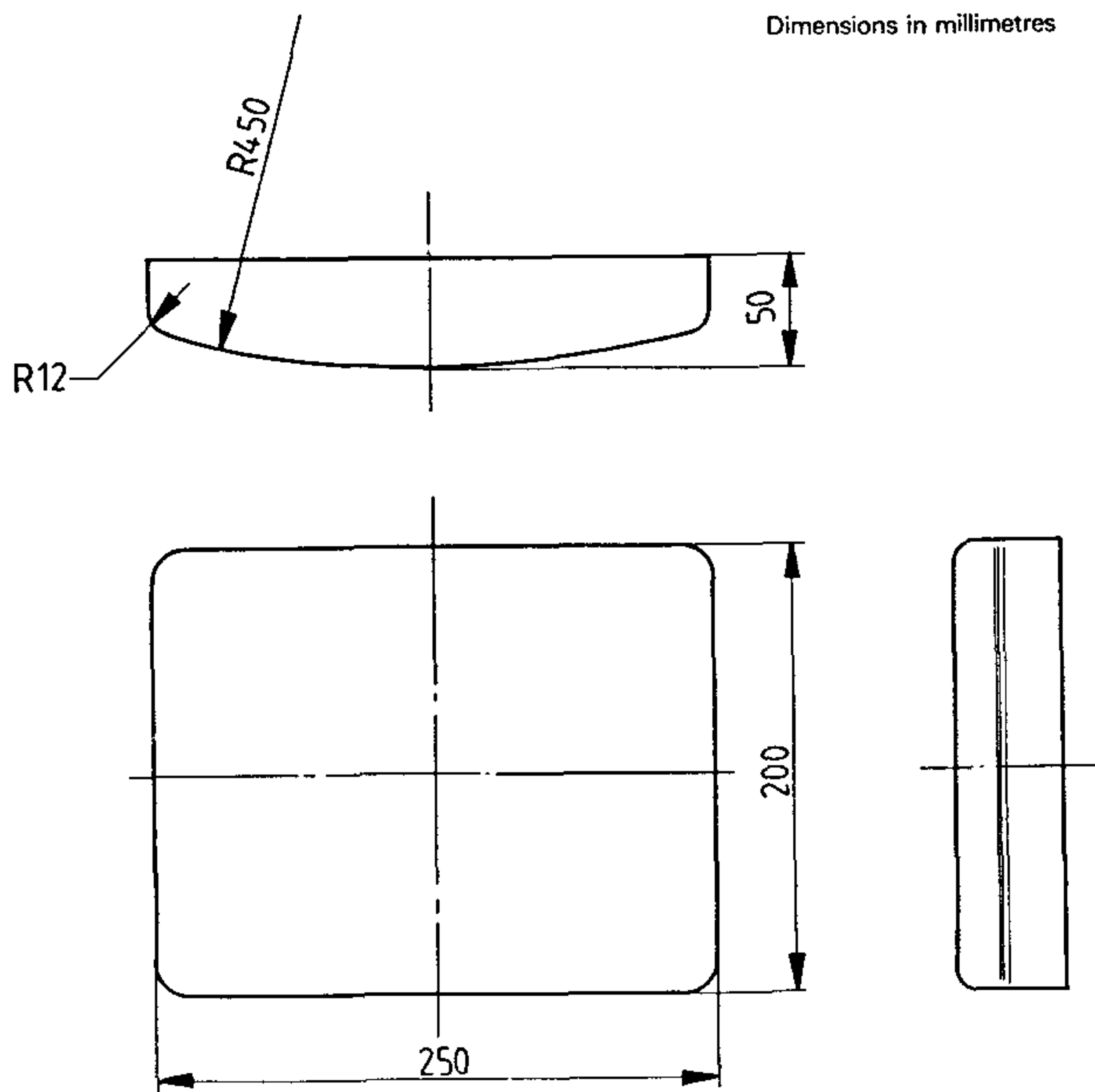

Figure 15 – Details of back loading pad

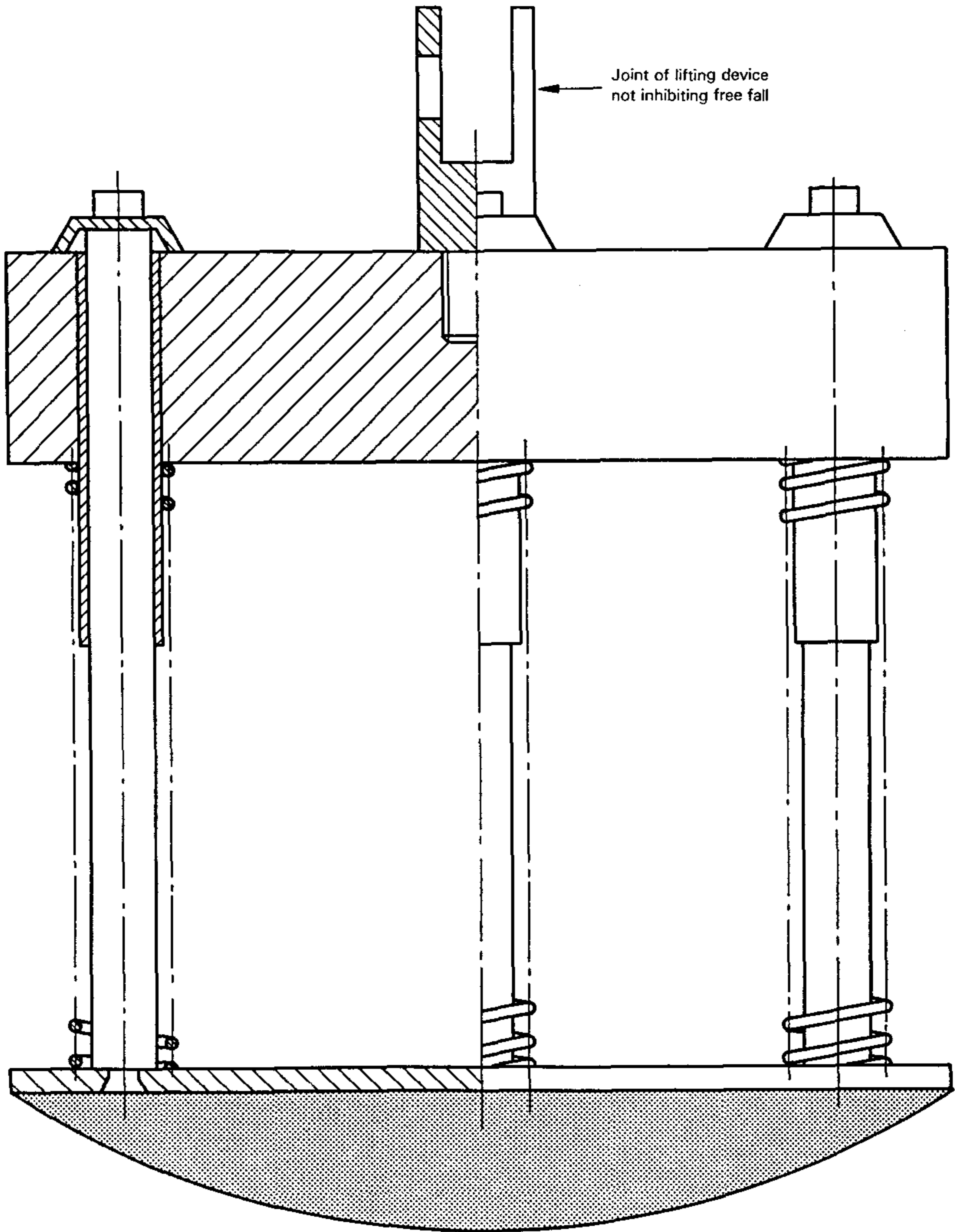
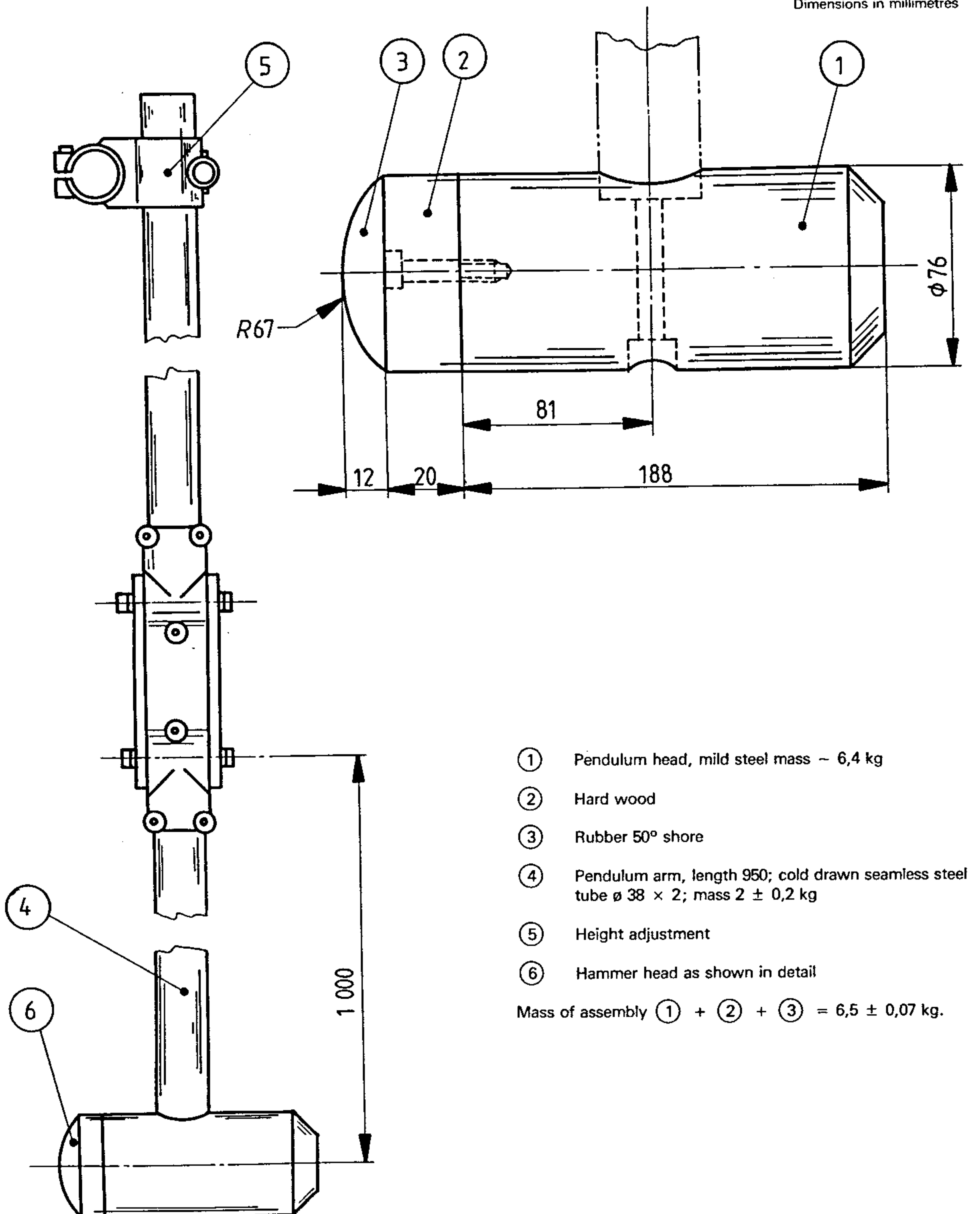

Figure 16 — Details of seat impacter

Dimensions in millimetres



- ① Pendulum head, mild steel mass ~ 6,4 kg
- ② Hard wood
- ③ Rubber 50° shore
- ④ Pendulum arm, length 950; cold drawn seamless steel tube $\phi 38 \times 2$; mass $2 \pm 0,2$ kg
- ⑤ Height adjustment
- ⑥ Hammer head as shown in detail

Mass of assembly ① + ② + ③ = $6,5 \pm 0,07$ kg.

NOTE — Pendulum head is drawn turned 90° from working position.

Figure 17 — Details of pendulum impact hammer

Table — Summary of tests and test level¹⁾

Test	Loading	Test levels					
		1	2	3	4	5	
7.1 Seat static load	force, N 10 times	—	1 100	1 300	1 600	2 000	
7.2 Back static load Balancing load	force, N force, N 10 times	— —	410 1 100	560 1 300	760 1 600	760 2 000	
7.3 Arm sideways static load Wing sideways static load	force, N	200	300	400	600	900	
	force, N 10 times	—	200	300	400	500	
7.4 Arm downwards static load	force, N 10 times	300	700	800	900	1 000	
7.5 Seat fatigue test	cycles seat load 950 N	12 500	25 000	50 000	100 000	200 000	
7.6 Back fatigue test Balancing load	cycles back load 330 N seat load 950 N	12 500	25 000	50 000	100 000	200 000	
7.7 Leg forward static load Balancing seat load	force, N	300	375	500	620	760	
	10 times	780	780	1 000	1 250	1 800	
7.8 Leg sideways static load Balancing seat load	force, N	250	300	390	490	760	
	10 times	780	780	1 000	1 250	1800	
7.9 Diagonal base load	force, N 10 times	125	250	375	500	620	
7.10 Seat impact test	drop height, mm 10 times	—	140	180	240	300	
7.11 Back impact test	height, mm	70	120	210	330	620	
	angle, degrees	20	28	38	48	68	
7.12 Arm impact test	10 times						
7.13 Drop test	— Stackable or special design of chairs and stools with legs or pedestals longer than 200 mm	drop height, mm 10 times at 10°	150	300	450	600	900
	— Non-stacking chairs with castors or swivelling glides with legs or pedestals longer than 200 mm	drop height, mm 10 times at 10°	—	150	200	300	450
	— Chairs and stools with legs or pedestals shorter than 200 mm	drop height, mm 10 times at 10°	—	75	100	150	250

1) For each test it is recommended the values be chosen from those given in the table whatever the intended use of the furniture.

Annex

Determination of seat and back loading positions

(This annex forms a part of the Standard.)

A.1 Introduction

This method determines the seat and back loading positions that are specified in this International Standard as distances measured from the seat and back intersection point. The determination of alternative loading points measured from the front edge of the seat or the top of the back is carried out in the normal manner.

A.2 Apparatus

A chair loading position template (see figures 18 and 19) consisting of two shaped members fastened together by a pivot at one end. The contours of the shaped surfaces are so devised as to sink into the upholstery for a representative distance and at moderate loads. For this purpose the seat loading arm shall have a total mass of 20 kg, applied through the seat loading point.

The apparatus is marked as shown in figure 18 so that the template can be positioned easily with the two members at 90° to each other.

Loading points A and B correspond to those points on a chair being 175 mm forward of the seat and back intersection point on the seat and 300 mm upward from the seat and back intersection point on the back.

Loading point C corresponds to the point on a stool as 175 mm from one edge.

NOTE — In some cases it may not be possible to determine the loading points by means of the template. In such cases, the report should include information as to the choice of loading points.

A.3 Method

A.3.1 Chairs

Position the template with its load applied at the seat loading point on the centreline of the chair as far towards the rear as possible. Adjust its position by pushing the backloading portion into the back, so levering the seat portion forwards until the shape of the template correlates to that of the chair (see figure 20). Mark the required loading positions from the template.

A.3.2 Stools

Set up the apparatus at 90° with the aid of the mark as shown in figure 18. Place on the stool as shown in figure 20. Mark the required loading position from the template.

Dimensions in millimetres

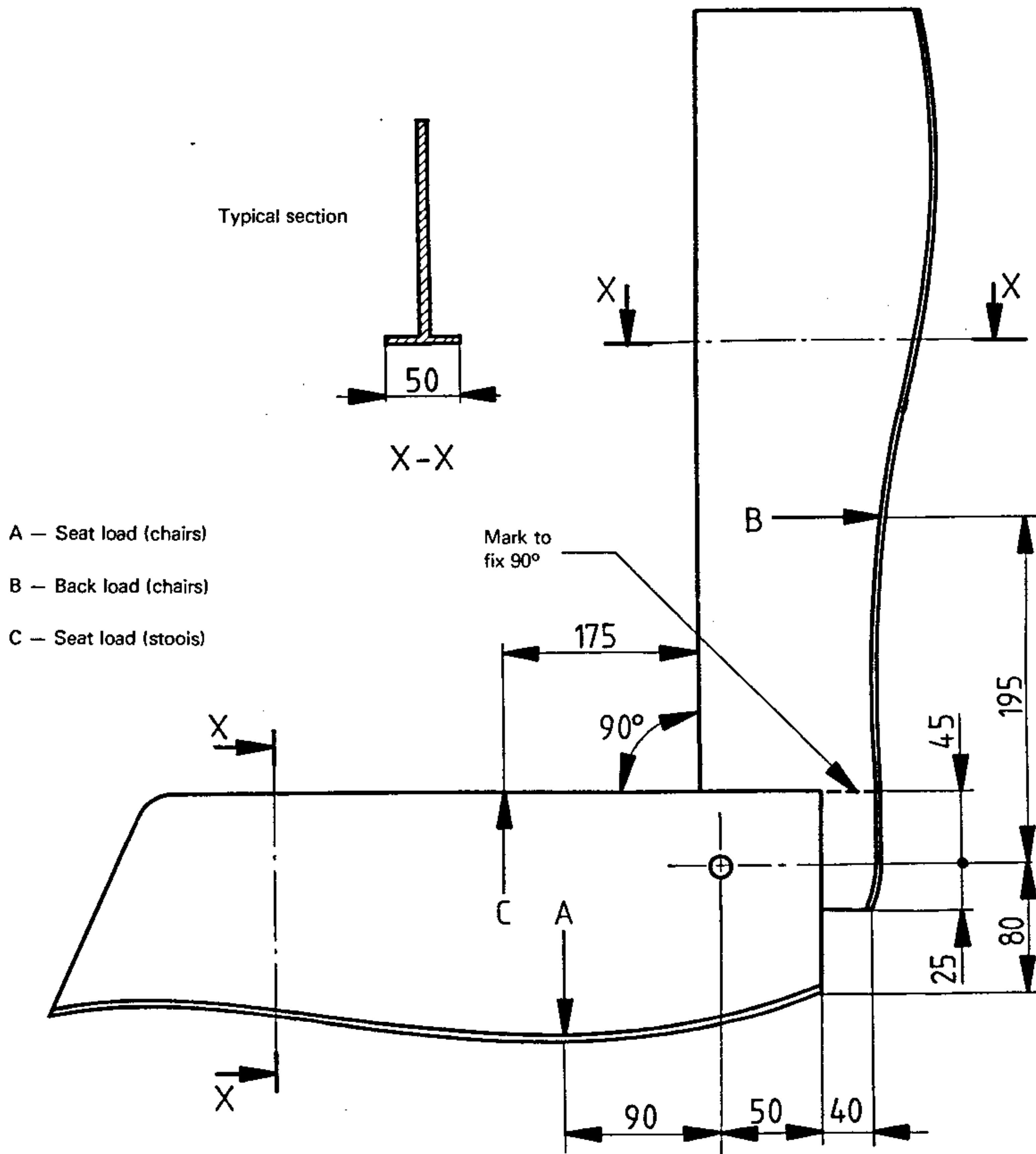

Figure 18 — Chair loading position template

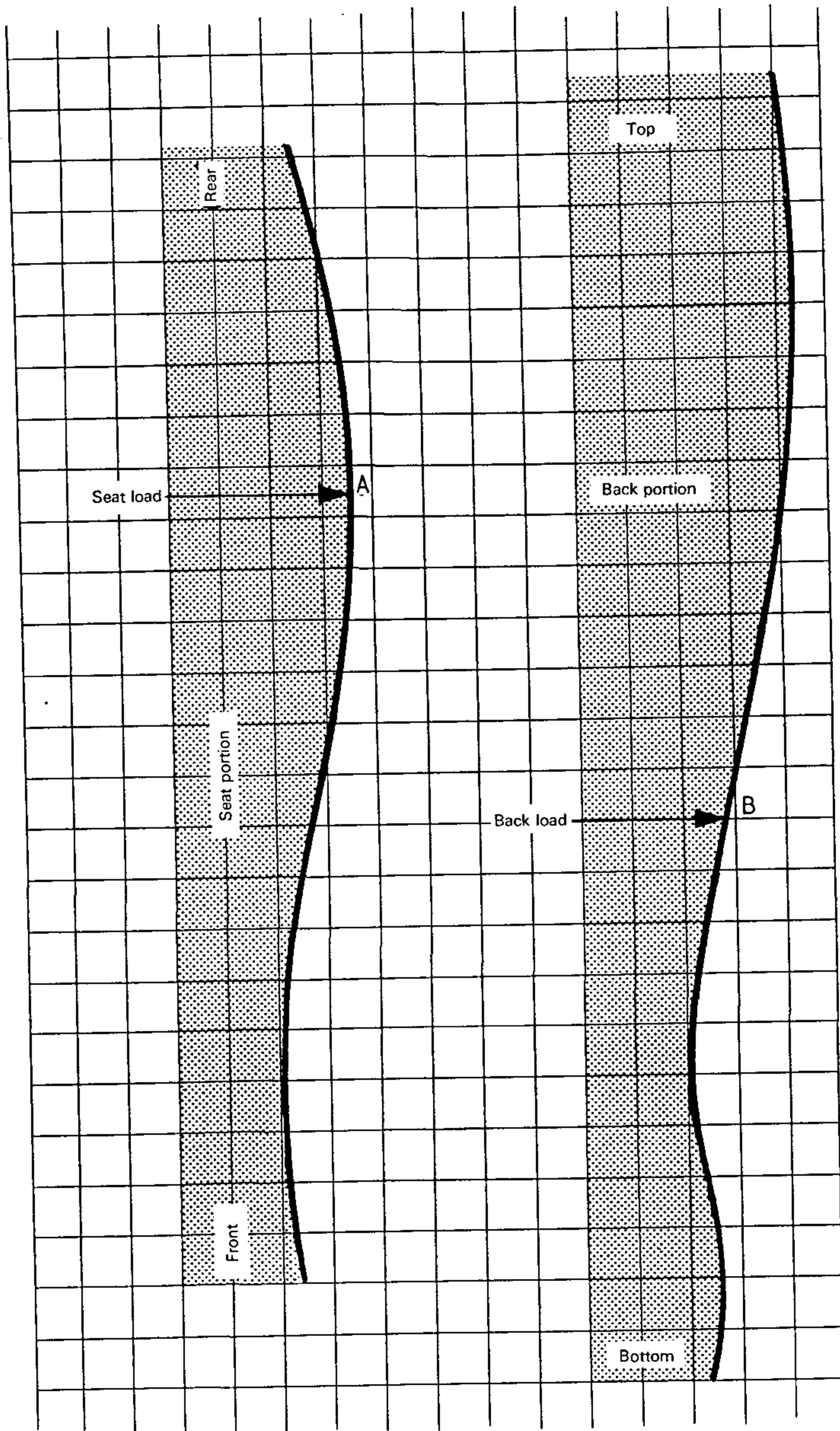

Figure 19 — Loading surface curves for chair seat and back loading template assembly

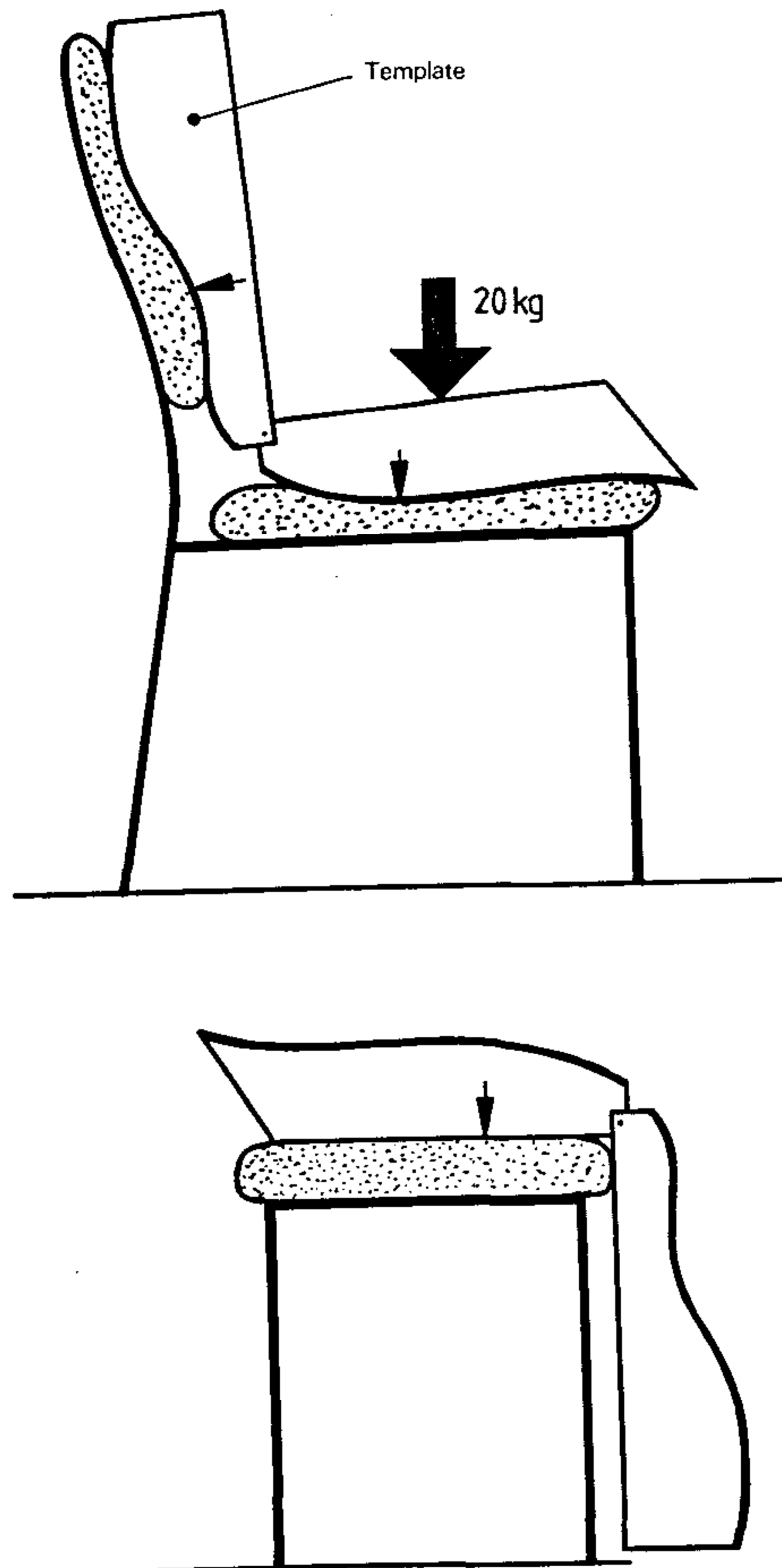

Figure 20 — Position of chair loading position template on chairs and stools

UDC 645.41 : 620.169.1

Descriptors: furniture, chairs, tests, static tests, impact tests, fatigue tests, wear tests, determination, strength, durability.

Price based on 20 pages
