**Plain bearings — Testing of the
tribological behaviour of bearing
materials —**

**Part 1:
Testing of bearing metals**

*Paliers lisses — Essai du comportement tribologique des matériaux
antifriction —*

Partie 1: Essai des matériaux métalliques



Reference number
ISO 7148-1:2012(E)

© ISO 2012

.....



COPYRIGHT PROTECTED DOCUMENT

© ISO 2012

All rights reserved. Unless otherwise specified, no part of this publication may be reproduced or utilized in any form or by any means, electronic or mechanical, including photocopying and microfilm, without permission in writing from either ISO at the address below or ISO's member body in the country of the requester.

ISO copyright office
Case postale 56 • CH-1211 Geneva 20
Tel. + 41 22 749 01 11
Fax + 41 22 749 09 47
E-mail copyright@iso.org
Web www.iso.org

Published in Switzerland

Contents

	Page
Foreword	iv
1 Scope	1
2 Normative references	1
3 Symbols and units	1
4 Special features for the tribological testing of metallic bearing materials	2
5 Test methods	2
5.1 Test method A — Pin-on-disc	2
5.2 Test method B — Block-on-ring	3
5.3 Test method C — Rotation under thrust load	4
6 Test specimens	5
6.1 Disc	5
6.2 Ring	5
6.3 Pin	5
6.4 Block	5
6.5 Sleeve	5
6.6 Plate	6
6.7 Preparation of the test specimens	6
7 Test methods and test equipment	7
8 Lubrication	7
9 Designation	7
10 Test conditions	7
11 Test procedure	8
Annex A (informative) Test report	9
Bibliography	11

Foreword

ISO (the International Organization for Standardization) is a worldwide federation of national standards bodies (ISO member bodies). The work of preparing International Standards is normally carried out through ISO technical committees. Each member body interested in a subject for which a technical committee has been established has the right to be represented on that committee. International organizations, governmental and non-governmental, in liaison with ISO, also take part in the work. ISO collaborates closely with the International Electrotechnical Commission (IEC) on all matters of electrotechnical standardization.

International Standards are drafted in accordance with the rules given in the ISO/IEC Directives, Part 2.

The main task of technical committees is to prepare International Standards. Draft International Standards adopted by the technical committees are circulated to the member bodies for voting. Publication as an International Standard requires approval by at least 75 % of the member bodies casting a vote.

Attention is drawn to the possibility that some of the elements of this document may be the subject of patent rights. ISO shall not be held responsible for identifying any or all such patent rights.

ISO 7148-1 was prepared by Technical Committee ISO/TC 123, *Plain bearings*, Subcommittee SC 2, *Materials and lubricants, their properties, characteristics, test methods and testing conditions*.

This third edition cancels and replaces the second edition (ISO 7148-1:1999), which has been technically revised.

ISO 7148 consists of the following parts, under the general title *Plain bearings — Testing of the tribological behaviour of bearing materials*:

- *Part 1: Testing of bearing metals*
- *Part 2: Testing of polymer-based bearing materials.*

Plain bearings — Testing of the tribological behaviour of bearing materials —

Part 1: Testing of bearing metals

1 Scope

This part of ISO 7148 specifies tribological tests of metallic bearing materials for plain bearings under conditions of boundary lubrication.

The test procedures described in this part of ISO 7148 enable the friction and wear behaviour of bearing material/mating/lubricant combinations to be compared with that of other combinations, thus facilitating the selection of a bearing material for running repeatedly or for long periods under conditions of boundary lubrication, low speed and continuous sliding. Owing to differences in test conditions, measured friction and wear values can be expected to vary from one test facility to another.

The test results give useful information for practical application only if all parameters of influence are identical. The more the test conditions deviate from the actual application, the greater the uncertainty of the applicability of the results.

2 Normative references

The following referenced documents are indispensable for the application of this document. For dated references, only the edition cited applies. For undated references, the latest edition of the referenced document (including any amendments) applies.

ISO 4385, *Plain bearings — Compression testing of metallic bearing materials*

3 Symbols and units

See Table 1.

Table 1 — Symbols and units

Symbol	Term	Unit
A, B, C	Test method	—
a	Sliding distance	km
A_5	Elongation at fracture	%
f	Coefficient of friction; ratio between friction force and normal force, i.e.: $f = \frac{F_f}{F_n}$	—
F_f	Friction force	N
F_n	Normal force	N
K_A	Overlap ratio (area of contact divided by area of wear track)	—

Table 1 (continued)

Symbol	Term	Unit
K_w	Coefficient of wear, volumetric wear rate related to the normal force, i.e.: $K_w = \frac{V_w}{F_n \times a} = \frac{w_v}{F_n}$	mm ³ /(N · km)
l_w	Linear wear as measured by change in distance	mm
m_w	Mass of material removed by wear	g
Ra	Surface roughness	µm
$R_{d0,2}$	Compression limit 0,2 %	N/mm ²
R_m	Tensile strength	N/mm ²
$R_{p0,2}$	0,2 % Proof stress	N/mm ²
T	Specimen's temperature near the sliding surface during testing under steady-state conditions	°C
T_{amb}	Ambient temperature	°C
T_L	Lubricant temperature	°C
t_{Ch}	Test duration	h
U	Sliding velocity	m/s
V_w	Material removed by wear as measured by change in volume	mm ³
w_l	Linear wear rate, i.e.: $w_l = \frac{l_w}{a}$	mm/km
w_v	Volumetric wear rate, i.e.: $w_v = \frac{V_w}{a}$	mm ³ /km
η	Lubricant viscosity	mPa · s

4 Special features for the tribological testing of metallic bearing materials

Plain bearings made of metallic materials usually require lubrication (e.g. oil or grease) to ensure a low rate of friction and wear.

If possible, lubricated plain bearings should be designed to run under hydrodynamic conditions, where the sliding surfaces of the journal and the plain bearing are always fully separated by a film of lubricant. Under such conditions, friction depends on the rheological properties of the lubricant, and wear normally does not occur.

If hydrodynamic operation cannot be ensured, boundary lubrication prevails and wear of the bearing and mating material is likely. This may be during the starting or running down phase of a hydrodynamic plain bearing or when high loads, low sliding velocities, poor lubrication or oscillating movements prevent hydrodynamic action.

5 Test methods

5.1 Test method A — Pin-on-disc

Figure 1 shows a schematic drawing of a disc and pin assembly.

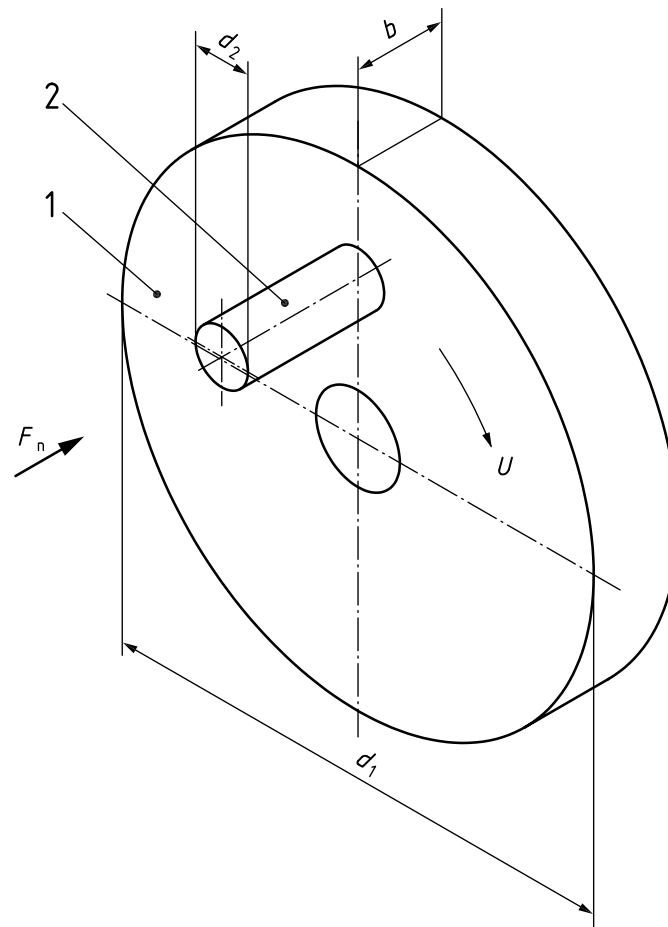

Key

- 1 disc or ring
- 2 pin or block

Figure 1 — Pin-on-disc test method

5.2 Test method B — Block-on-ring

Figure 2 shows a schematic drawing of a block and ring assembly.

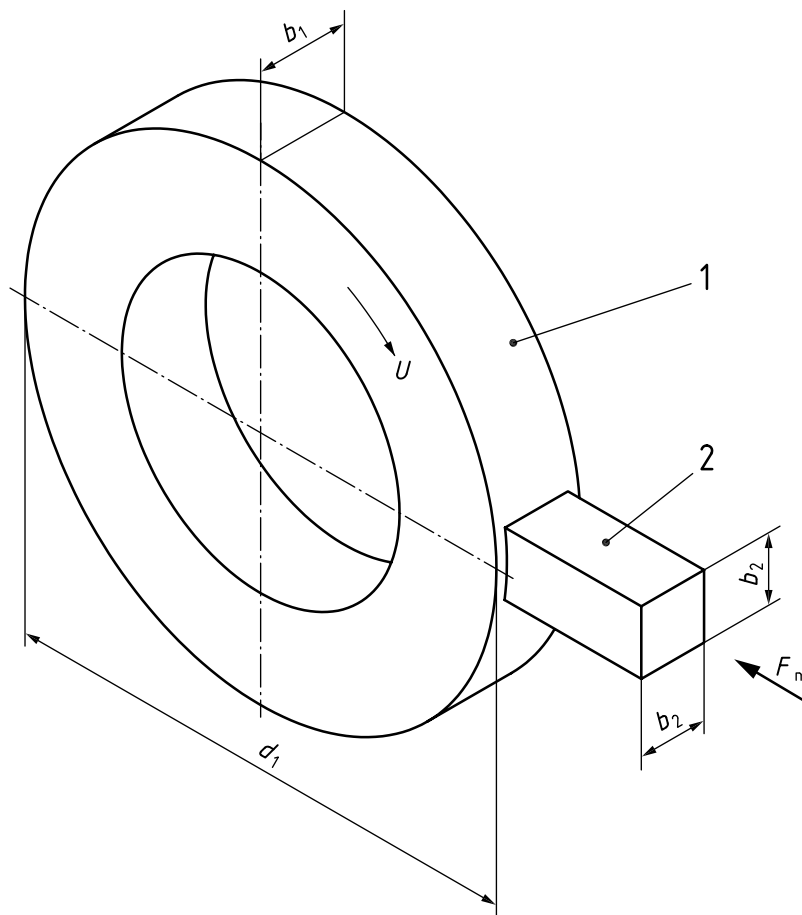

- Key**
- 1 disc or ring
 - 2 pin or block

Figure 2 — Block-on-ring test method

5.3 Test method C — Rotation under thrust load

Figure 3 shows schematic drawings of a sleeve-to-sleeve and sleeve-to-plate assembly.

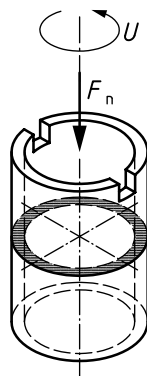

a) C1 — Sleeve-to-sleeve

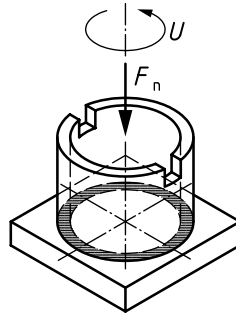

b) C2 — Sleeve-to-plate

Figure 3 — Rotation under thrust load

6 Test specimens

6.1 Disc

The disc shall have the following preferred dimensions:

- diameter, d_1 : 40 mm to 110 mm;
- width b : 8 mm to 12 mm.

The diameter of the sliding track shall be noted in the test report.

6.2 Ring

The ring shall have an outside diameter, d_1 , of 40 mm to 80 mm and the width, b_1 , of the ring shall exceed the width, b_2 , of the block.

6.3 Pin

The pin shall preferably have a diameter, d_2 , of 3 mm to 10 mm.

6.4 Block

The cross-section of the block shall be 5 mm to 10 mm high and 5 mm to 10 mm wide.

6.5 Sleeve

The sleeve can be made by machining. The preferred basic dimensions of the sleeve are shown in Figure 4.

Dimensions in millimetres

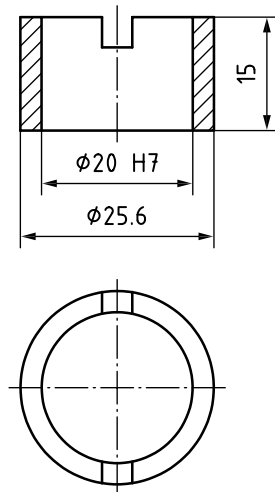

Figure 4 — Dimensions of sleeve

6.6 Plate

The plate can be made by machining. The preferred basic dimensions of the sleeve are shown in Figure 5.

Dimensions in millimetres

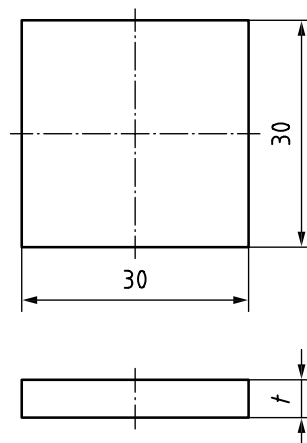

Figure 5 — Dimensions of plate

6.7 Preparation of the test specimens

After preparing the test surfaces with the same machining methods in order to obtain a suitable surface finish (similar to the application which is to be simulated), the specimens shall be thoroughly cleaned. An example of a cleaning method is:

- cleaning with alcohol, e.g. ultrasonic bath;
- drying in hot air;
- rinsing with hexane;
- drying in a drying stove at 110 °C.

7 Test methods and test equipment

The pin, block, sleeve or plate, made of the bearing materials, is pressed with a known normal force, F_n , against the rotating specimen (disc, ring or sleeve) made from the material of the mating component.

In practice, surfaces with cylindrical surface curvature (journal bearings) are also tested by test method B. If they are multilayer materials, there are two alternatives:

- a) adapt the radius of the ring to that of the block (see Figure 2);
- b) begin testing with line contact (radius of the block to be larger than the radius of the ring).

The linear wear should not exceed the thickness of the surface bearing material layer. For thin layers, test method A (pin-on-disc) and test method C (thrust rotation) are preferred.

If tests are performed under an other-than-normal atmosphere, use shall be made of either a sufficiently airtight chamber or a high rate of gas flow.

Equipment for the continuous measurement of friction and wear shall be available.

If grease lubrication is to be used, the equipment shall be such that sufficient grease is continuously supplied to the sliding track.

Vibrations in the loading mechanism, which can cause undefined variations in the applied normal force, shall be avoided.

8 Lubrication

Oil or grease lubrication shall be used depending on the practical application. The contact surface between the pin, block, sleeve or plate and the disc, ring or sleeve shall be completely filled with lubricant.

When oil lubrication is used, it is preferable for the specimens to be completely immersed in the oil. Spray lubrication may also be used, assuming that the volume of the lubricant supplied is sufficient to ensure that the wear rate is not dependent upon the lubricant flow rate. The oil temperature shall be kept constant.

NOTE Test results can vary widely depending on the lubricant used.

9 Designation

EXAMPLE The testing of the tribological behaviour of metallic bearing materials according to test method A (pin-on-disc) is designated as follows:

Test ISO 7148-1 -A

10 Test conditions

When testing different material/lubricant combinations comparatively, the method of machining and finishing the pin, block, sleeve or plate (bearing material) and the disc, ring or sleeve (mating material), and the following independent test variables, shall all be kept constant during the test programme:

- initial surface roughness, R_a , of the specimens;
- normal force, F_n ;
- lubricant temperature, T_L ;
- sliding distance, a ;
- sliding velocity, U ;

— overlap ratio, K_A .

In order to simulate friction and wear in a given plain bearing, realistic values of surface roughness, normal force, oil temperature and a sufficiently long sliding distance should be chosen.

When materials are being evaluated for specific applications, it is important that the surfaces be typical for that application, and constant for each test.

At prolonged running under conditions of boundary lubrication, the roughness of the mating material surface can change gradually as a result of contact with the bearing material. This, in turn, may lead to change in the wear rate of the bearing material. In evaluating materials for applications in which the plain bearing is expected to run under conditions of boundary lubrication for appreciable periods of time, this can be taken into account by performing a long-term test, measuring the wear volume as a function of the sliding distance. After the test has been completed, the roughness of the mating material surface, R_a , should be measured and given with the test results. A newly prepared surface shall be used for each test.

As far as the normal force, F_n , is concerned, the most widely accepted compromise is to make the maximum force per unit pin, block or sleeve area equal to the force per unit projected bearing area (specific load) of the practical application.

When comparing material/lubricant combinations in which the bearing materials have different mechanical properties and load capacities, the test may be carried out with values of normal force which generate specific loads (normal force divided by projected contact area) ranging up to one third of the 0,2 % proof stress, $R_{p0,2}$, or one third of the 0,2 % compression limit, $R_{d0,2}$, (as specified in ISO 4385) at the temperature of the application. In practice, this value is generally considered to be the maximum permissible force per unit projected area for each material in highly loaded plain bearings under boundary lubrication conditions.

For T_L , a temperature corresponding to the highest temperature which is expected to occur in practice shall be chosen. The sliding velocity, U , shall be so low that the system does not reach hydrodynamic conditions.

If the friction and wear behaviour of a bearing material/mating/lubricant combination is to be compared with other combinations without reference to a specific application, the normal force, F_n , and the lubricant temperature T_L (and possibly the surface roughness values R_a) should be varied, preferably, between wide limits.

11 Test procedure

Friction sliding distance and wear sliding distance curves shall be recorded so that, among others, the periods of running in and steady-state can be distinguished. The total sliding distance shall be presented in the results.

After the tests have been completed, wear of the mating material surface shall also be measured, e.g. by profile tracing with a stylus instrument, so that the contribution of the wear of the mating material to the total wear may be evaluated. This also reveals whether or not the mating material surface has been scratched by contact with the bearing material. In addition, wear of the bearing material shall be determined by weighing before and after the test (after removal of all loose debris). The test parameters shall be chosen so that the mass of the bearing material removed by wear is more than 5 mg.

After the test has been completed, inspect the surface conditions of both the sliding surfaces (formation of a reaction layer, transferred material, scratches, etc.).

NOTE Tribological test results can vary considerably from one test to another.

To obtain results that are as reliable as possible, it is necessary to run several tests of each combination.

Annex A (informative)

Test report

Unless otherwise agreed, the test report shall include the following information:

Table A.1 — Test report

Test ISO 7148-1	Symbol	Unit	Pin, block, sleeve or plate	Disc, ring or sleeve
Specimens:				
Type/name				
Chemical composition				
Method of production				
Heat treatment				
Micro structure				
Mechanical properties:				
Hardness		HB, HV, HRC		
Tensile strength	R_m	N/mm ²		
0,2 % Proof stress	$R_{p0,2}$	N/mm ²		
Elongation at fracture	A_5	%		
Dimensions		mm		
Diameter of sliding track		mm		
Surface treatment				
Surface finishing method				
Surface roughness	R_a	μm		
Lubricant:				
Type/name				
Chemical composition				
Viscosity at °C	η	mPa·s		
Environmental conditions:				
Atmosphere				
Relative humidity				
Ambient temperature	T_{amb}	°C		
Test conditions:				
Test method				
Normal force	F_n	N		
Sliding velocity	U	m/s		
Lubricant temperature	T_L	°C		
Test duration	t_{Ch}	h		
Sliding distance	a	km		

Table A.1 (continued)

Test ISO 7148-1		Symbol	Unit	Pin, block, sleeve or plate	Disc, ring or sleeve
Test results:					
	Coefficient of friction under steady-state conditions	f	-		
	Specimen temperature	T	°C		
	Linear wear rate ^a	w_l	mm/km		
	Volumetric wear rate ^a	w_v	mm ³ /km		
	Coefficient of wear ^a	K_w	mm ³ /(N·km)		
	Total wear volume: ^a				
	Calculated from the wear-sliding distance curve	V_w	mm ³		
	Calculated from the loss of mass	V_m	g		
	Surface condition:				
	Roughness	Ra	µm		
	Transferred material				
	Reaction layer				
	Scratches				
Location:		Date:		Operator:	
^a When disc or ring wear is neglected. For multilayer materials, the thickness of the sliding surface layer shall be thick enough to enable a steady-state condition to be achieved or else the specimen shall be shaped to match the radius of the disc.					

Bibliography

- [1] ISO 4378-1, *Plain bearings — Terms, definitions, classification and symbols — Part 1: Design, bearing materials and their properties*
- [2] ISO 4378-2, *Plain bearings — Terms, definitions, classification and symbols — Part 2: Friction and wear*
- [3] ISO 4378-3, *Plain bearings — Terms, definitions, classification and symbols — Part 3: Lubrication*
- [4] ISO 4381, *Plain bearings — Tin casting alloys for multilayer plain bearings*
- [5] ISO 4382-1, *Plain bearings — Copper alloys — Part 1: Cast copper alloys for solid and multilayer thick-walled plain bearings*
- [6] ISO 4382-2, *Plain bearings — Copper alloys — Part 2: Wrought copper alloys for solid plain bearings*
- [7] ISO 4383, *Plain bearings — Multilayer materials for thin-walled plain bearings*
- [8] ISO 7148-2, *Testing of the tribological behaviour of bearing materials — Testing of polymer-based bearing materials*
- [9] BEGELINGER, A. and DE GEE, A.W.J., Wear in lubricated journal bearings, *Transactions ASME*. **100** (1), 1978, pp. 104–109
- [10] HABIG, K.-H. BROSZEIT, E. and DE GEE, A.W.J., Friction and wear test on metallic bearing materials for oil lubricated bearing. *Wear*. 69, 1981, pp. 43–54

.....

ICS 21.100.10

Price based on 11 pages