

INTERNATIONAL STANDARD

ISO 7089

Second edition
2000-06-01

Plain washers — Normal series — Product grade A

Rondelles plates — Série normale — Grade A



Reference number
ISO 7089:2000(E)

© ISO 2000

PDF disclaimer

This PDF file may contain embedded typefaces. In accordance with Adobe's licensing policy, this file may be printed or viewed but shall not be edited unless the typefaces which are embedded are licensed to and installed on the computer performing the editing. In downloading this file, parties accept therein the responsibility of not infringing Adobe's licensing policy. The ISO Central Secretariat accepts no liability in this area.

Adobe is a trademark of Adobe Systems Incorporated.

Details of the software products used to create this PDF file can be found in the General Info relative to the file; the PDF-creation parameters were optimized for printing. Every care has been taken to ensure that the file is suitable for use by ISO member bodies. In the unlikely event that a problem relating to it is found, please inform the Central Secretariat at the address given below.

© ISO 2000

All rights reserved. Unless otherwise specified, no part of this publication may be reproduced or utilized in any form or by any means, electronic or mechanical, including photocopying and microfilm, without permission in writing from either ISO at the address below or ISO's member body in the country of the requester.

ISO copyright office
Case postale 56 • CH-1211 Geneva 20
Tel. + 41 22 749 01 11
Fax + 41 22 734 10 79
E-mail copyright@iso.ch
Web www.iso.ch

Printed in Switzerland

Foreword

ISO (the International Organization for Standardization) is a worldwide federation of national standards bodies (ISO member bodies). The work of preparing International Standards is normally carried out through ISO technical committees. Each member body interested in a subject for which a technical committee has been established has the right to be represented on that committee. International organizations, governmental and non-governmental, in liaison with ISO, also take part in the work. ISO collaborates closely with the International Electrotechnical Commission (IEC) on all matters of electrotechnical standardization.

International Standards are drafted in accordance with the rules given in the ISO/IEC Directives, Part 3.

Draft International Standards adopted by the technical committees are circulated to the member bodies for voting. Publication as an International Standard requires approval by at least 75 % of the member bodies casting a vote.

Attention is drawn to the possibility that some of the elements of this International Standard may be the subject of patent rights. ISO shall not be held responsible for identifying any or all such patent rights.

International Standard ISO 7089 was prepared by Technical Committee ISO/TC 2, *Fasteners*.

This second edition cancels and replaces the first edition (ISO 7089:1983), which has been technically revised.

Plain washers — Normal series — Product grade A

1 Scope

This International Standard specifies the characteristics of normal-series, product-grade-A plain washers in the 200 HV and 300 HV hardness classes and of nominal sizes (nominal thread diameters) ranging from 1,6 mm to 64 mm inclusive.

Washers of hardness class 200 HV are suitable for

- hexagon bolts and screws of product grades A and B in property classes up to and including 8.8;
- hexagon nuts of product grades A and B in property classes up to and including 8;
- hexagon bolts, screws and nuts of stainless steel of similar chemical composition;
- case-hardened thread rolling screws.

Washers of hardness class 300 HV are suitable for

- hexagon bolts and screws of product grades A and B in property classes up to and including 10.9;
- hexagon nuts of product grades A and B in property classes up to and including 10.

If dimensions other than those listed in this International Standard are required, they should be selected from those given in ISO 887.

When soft material pieces are clamped, or large clearance holes in the workpiece are used, the user should check the technical suitability of this type of washer.

2 Normative references

The following normative documents contain provisions which, through reference in this text, constitute provisions of this International Standard. For dated references, subsequent amendments to, or revisions of, any of these publications do not apply. However, parties to agreements based on this International Standard are encouraged to investigate the possibility of applying the most recent editions of the normative documents indicated below. For undated references, the latest edition of the normative document referred to applies. Members of ISO and IEC maintain registers of currently valid International Standards.

ISO 887:2000, *Plain washers for metric bolts, screws and nuts for general purposes — General plan.*

ISO 3269:2000, *Fasteners — Acceptance inspection.*

ISO 3506-1:1997, *Mechanical properties of corrosion-resistant stainless-steel fasteners — Part 1: Bolts, screws and studs.*

ISO 4042:1999, *Fasteners — Electroplated coatings.*

ISO 4759-3:2000, *Tolerances for fasteners — Part 3: Plain washers for bolts, screws and nuts — Product grades A and C.*

ISO 6507-1:1997, *Metallic materials — Vickers hardness test — Part 1: Test method.*

ISO 10683—¹⁾, *Fasteners — Non-electrolytically applied zinc flake coatings.*

3 Dimensions

See Figure 1 and Tables 1 and 2.

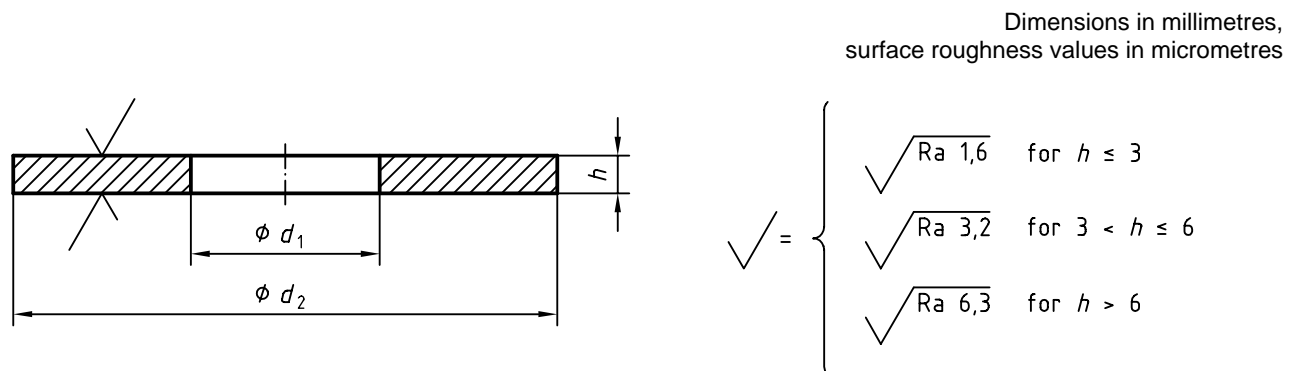

Figure 1 — Dimensions

1) To be published.

Table 1 — Preferred dimensions

Dimensions in millimetres

Nominal size (Nominal thread diameter, d)	Clearance hole		Outside diameter		Thickness		
	d_1		d_2		h		
	nom. (min.)	max.	nom. (max.)	min.	nom.	max.	min.
1,6	1,70	1,84	4,0	3,7	0,3	0,35	0,25
2	2,20	2,34	5,0	4,7	0,3	0,35	0,25
2,5	2,70	2,84	6,0	5,7	0,5	0,55	0,45
3	3,20	3,38	7,00	6,64	0,5	0,55	0,45
4	4,30	4,48	9,00	8,64	0,8	0,9	0,7
5	5,30	5,48	10,00	9,64	1	1,1	0,9
6	6,40	6,62	12,00	11,57	1,6	1,8	1,4
8	8,40	8,62	16,00	15,57	1,6	1,8	1,4
10	10,50	10,77	20,00	19,48	2	2,2	1,8
12	13,00	13,27	24,00	23,48	2,5	2,7	2,3
16	17,00	17,27	30,00	29,48	3	3,3	2,7
20	21,00	21,33	37,00	36,38	3	3,3	2,7
24	25,00	25,33	44,00	43,38	4	4,3	3,7
30	31,00	31,39	56,00	55,26	4	4,3	3,7
36	37,00	37,62	66,0	64,8	5	5,6	4,4
42	45,00	45,62	78,0	76,8	8	9	7
48	52,00	52,74	92,0	90,6	8	9	7
56	62,00	62,74	105,0	103,6	10	11	9
64	70,00	70,74	115,0	113,6	10	11	9

Table 2 — Non-preferred dimensions

Dimensions in millimetres

Nominal size (Nominal thread diameter, d)	Clearance hole		Outside diameter		Thickness		
	d_1		d_2		h		
	nom. (min.)	max.	nom. (max.)	min.	nom.	max.	min.
3,5	3,70	3,88	8,00	7,64	0,5	0,55	0,45
14	15,00	15,27	28,00	27,48	2,5	2,7	2,3
18	19,00	19,33	34,00	33,38	3	3,3	2,7
22	23,00	23,33	39,00	38,38	3	3,3	2,7
27	28,00	28,33	50,00	49,38	4	4,3	3,7
33	34,00	34,62	60,0	58,8	5	5,6	4,4
39	42,00	42,62	72,0	70,8	6	6,6	5,4
45	48,00	48,62	85,0	83,6	8	9	7
52	56,00	56,74	98,0	96,6	8	9	7
60	66,00	66,74	110,0	108,6	10	11	9

4 Requirements and International Standards of reference

See Table 3.

Table 3 — Specifications and International Standards of reference

Material ^a		Steel		Stainless steel		
	Grade ^b			A2	F1	C1
				A4		C4
	International Standard			ISO 3506-1		
Mechanical properties	Hardness class	200 HV	300 HV ^c		200 HV	
	Hardness range ^d	200 HV to 300 HV	300 HV to 370 HV		200 HV to 300 HV	
Tolerances	Product grade	A				
	International Standard	ISO 4759-3				
Surface finish	<p>Plain: i.e. washers to be supplied in natural finish, treated with a protective lubricant or with other coatings as agreed by customer and supplier.</p> <p>Requirements for electroplating covered in ISO 4042.</p> <p>Requirements for non-electrolytically applied zinc flake coatings covered in ISO 10683.</p> <p>For hardened and tempered washers, appropriate plating or coating processes should be employed to avoid hydrogen embrittlement. When washers are electroplated or phosphated, they shall be suitably treated immediately after plating or coating to obviate detrimental hydrogen embrittlement.</p> <p>All tolerances shall apply prior to the application of a plating or coating.</p>				<p>Plain: i.e. washers shall be supplied in natural finish.</p>	
Workmanship	Parts shall be free of irregularities or detrimental defects. No protruding burrs shall appear on the washer.					
Acceptability	Acceptance procedure covered in ISO 3269.					
<p>^a Other metallic materials as agreed between customer and supplier.</p> <p>^b Related to chemical composition only.</p> <p>^c Hardened and tempered.</p> <p>^d Hardness testing according to ISO 6507-1.</p> <p>Test force: HV 2 for nominal thickness $h \leq 0,6$ mm</p> <p> HV 10 for nominal thickness $0,6 < h \leq 1,2$ mm</p> <p> HV 30 for nominal thickness $h > 1,2$ mm</p>						

5 Designation

EXAMPLE 1 A normal-series, product-grade-A plain washer made of steel, of nominal size 8 mm and hardness class 200 HV is designated as follows:

Washer ISO 7089-8-200 HV

EXAMPLE 2 A normal-series, product-grade-A plain washer made of grade A2 stainless steel, of nominal size 8 mm and hardness class 200 HV is designated as follows:

Washer ISO 7089-8-200 HV-A2

ICS 21.060.30

Price based on 5 pages

© ISO 2000 – All rights reserved

00000000000000000000000000000000