

# INTERNATIONAL STANDARD

ISO  
7005-3

First edition  
1988-02-15



---

INTERNATIONAL ORGANIZATION FOR STANDARDIZATION  
ORGANISATION INTERNATIONALE DE NORMALISATION  
МЕЖДУНАРОДНАЯ ОРГАНИЗАЦИЯ ПО СТАНДАРТИЗАЦИИ

---

## **Metallic flanges —**

### **Part 3: Copper alloy and composite flanges**

*Brides métalliques —*

*Partie 3: Brides en alliages de cuivre et brides composites*

Reference number  
ISO 7005-3 : 1988 (E)

## Foreword

ISO (the International Organization for Standardization) is a worldwide federation of national standards bodies (ISO member bodies). The work of preparing International Standards is normally carried out through ISO technical committees. Each member body interested in a subject for which a technical committee has been established has the right to be represented on that committee. International organizations, governmental and non-governmental, in liaison with ISO, also take part in the work.

Draft International Standards adopted by the technical committees are circulated to the member bodies for approval before their acceptance as International Standards by the ISO Council. They are approved in accordance with ISO procedures requiring at least 75 % approval by the member bodies voting.

International Standard ISO 7005-3 was prepared by Technical Committee ISO/TC 5, *Ferrous metal pipes and metallic fittings*.

Users should note that all International Standards undergo revision from time to time and that any reference made herein to any other International Standard implies its latest edition, unless otherwise stated.

<b>Contents</b>	<b>Page</b>
<b>0</b> Introduction .....	1
<b>1</b> Scope and field of application .....	1
<b>2</b> Definitions and designation .....	2
<b>3</b> Pressure/temperature ( $p/T$ ) ratings .....	2
<b>4</b> Materials .....	2
<b>5</b> Dimensions .....	3
<b>6</b> Joint facings and surface finish .....	3
<b>7</b> Drilling and spot-facing .....	3
<b>8</b> Tolerances .....	3
<b>9</b> Marking .....	4
<b>10</b> Inspection and test .....	4
<b>11</b> Information to be supplied by the purchaser .....	4
<b>12</b> Limitations for flanges attached by soft solder or silver brazing .....	22
<b>Bibliography</b> .....	25
 <b>Annex</b>	
Application and installation .....	26

# Metallic flanges —

## Part 3: Copper alloy and composite flanges

### 0 Introduction

Various flange systems based on differing design criteria have been in use throughout the world for many years. Given the increasing difficulties arising from such a situation, this International Standard has been based on a single series of metallic flanges. ISO 7005 will be published in four parts as follows:

- Part 1: Steel flanges
- Part 2: Cast iron flanges
- Part 3: Copper alloy and composite flanges
- Part 4: Aluminium and aluminium alloy flanges

This part of ISO 7005 is based on the American and European copper alloy flange systems which have been combined to produce one International Standard with some changes to the dimensions specified in the two systems.

The flanges specified in this part of ISO 7005 are intended, in general, for use with copper or copper alloy tubes and pipework system components. Integral flanges are also intended for use with steel and cast iron pipework system components.

In the American system, flanges are designated by a Class rating but in this part of ISO 7005 the relevant Class ratings are designated by nominal pressure (PN) ratings.

The equivalent designations are as follows:

- Class 150: ISO PN20
- Class 300: ISO PN50

The ratings for ISO PN20 and ISO PN50 flanges are those based on American standards, established for use in copper alloy pipework systems. The ratings used in the European system remain as ISO PN6, ISO PN10, ISO PN16, ISO PN25 and ISO PN40.

In this part of ISO 7005, ISO copper alloys, in wrought and cast forms, have been specified where they are comparable with the American and European materials. In addition, an American specification has been retained for a ferrous backing flange

material and work is proceeding within ISO to prepare steel material specifications suitable for flange applications.

Flange details in all four parts of ISO 7005 are such that flanges having the same PN and nominal size (DN) values and compatible flange facings will mate together.

Users of this part of ISO 7005 should satisfy themselves that the flanges comply with any statutory requirements.

### 1 Scope and field of application

This part of ISO 7005 for a single system of flanges specifies requirements for circular copper alloy and composite flanges in the following nominal pressure ratings:

Series 1*	Series 2*
ISO PN10	ISO PN6
ISO PN16	ISO PN25
ISO PN20	ISO PN40
ISO PN50	

Attention is drawn to the need to refer to the pressure/temperature ( $p/T$ ) ratings in tables 10, 10a), 10b) and 10c) for the maximum permissible working pressures and temperatures, particularly for ISO PN20 and ISO PN50 flanges and for ISO PN6, ISO PN10, ISO PN16 and ISO PN25 flanges attached by soft solder or silver brazing.

This part of ISO 7005 specifies the types of flanges and their facings, dimensions, tolerances, bolt sizes (including copper alloy), flange face surface finish, marking, testing, inspection and materials.

#### NOTES

- 1 Dimensions of gaskets will be the subject of a future International Standard.
- 2 For guidance, information on the application and installation of flanges is given in the annex, which does not form an integral part of this part of ISO 7005.

\* Series 1 ratings are the basic ratings; series 2 ratings have limited application.

## 2 Definitions and designation

### 2.1 Definitions

**2.1.1 nominal size (DN):** A numerical designation of size which is common to all components in a piping system other than components designated by outside diameters or by thread size. It is a convenient round number for reference purposes and is only loosely related to manufacturing dimensions.

#### NOTES

- 1 Nominal size is designated by "DN" followed by the appropriate number.
- 2 This definition is in accordance with that given in ISO 6708.

**2.1.2 nominal pressure (PN):** A numerical designation which is a convenient rounded number for reference purposes.

All equipment of the same nominal size (DN) designated by the same PN number shall have compatible mating dimensions.

#### NOTES

- 1 The maximum allowable working pressure depends on materials, design and working temperatures and should be selected from the tables of pressure/temperature ratings given in this part of ISO 7005.
- 2 In this part of ISO 7005, nominal pressure is designated by the letters "ISO PN" followed by the appropriate reference number.
- 3 This definition of nominal pressure is in accordance with that given in ISO 7268.

### 2.2 Designation of types and facings

Figure 1 shows the basic commonly used flanges identified according to type.

- 01 — Plate flange in copper alloy for brazing or welding.
- 02 — Loose flange in ferrous material with a plate collar in copper alloy for brazing or welding.
- 04 — Loose flange in ferrous material with a welding neck collar in copper alloy for welding.
- 05 — Blank flange in copper alloy or in ferrous material clad with the jointing face in copper alloy.
- 07 — Loose flange in ferrous material with a slip-on collar in copper alloy for soft soldering, brazing or welding.
- 11 — Welding neck flange in copper alloy.
- 12 — Hubbed slip-on flange in copper alloy for soft soldering, brazing or welding.
- 14 — Hubbed slip-on flange in copper alloy for soft soldering, brazing or welding and supplied with tube-stops, the dimensions and locations of which shall be at the discretion of the manufacturer or as specified by the purchaser. In addition, integral grooves for preplaced soft-solder or brazing alloy rings may be machined in the sockets, the dimensions and locations of which shall be at the discretion of the manufacturer or as specified by the purchaser.
- 21 — Integral flange in copper alloy as part of some other equipment or component.

## 3 Pressure/temperature ( $p/T$ ) ratings

### 3.1 General

The pressure/temperature ratings of the materials specified in 4.1 shall be the maximum allowable non-shock working pressures at the temperatures given in tables 10, 10a), 10b) and 10c), as appropriate. Linear interpolation is permitted for intermediate temperatures.

### 3.2 Rating of flanged joints

Where two flanges in a flanged joint do not have the same pressure/temperature rating, the rating of the joint at any temperature shall not exceed the lower of the two flange ratings at that temperature.

### 3.3 Temperature

NOTE — The temperature shown for a corresponding pressure rating is considered to be the same as that of the contained fluid. Use of a pressure rating corresponding to a temperature other than that of the contained fluid is the responsibility of the user, subject to the requirements of any applicable code or regulation.

## 4 Materials

### 4.1 Range of materials

Flanges shall be manufactured from the materials specified in tables 11 and 11a) as appropriate.

#### NOTES

- 1 Each national standards organization has the responsibility of determining the national materials comparable with the materials specified in this part of ISO 7005.
- 2 Where there is an appropriate application standard, it is the responsibility of the purchaser to ensure compliance with the requirements of that standard.

### 4.2 Gaskets

The various types, dimensions and materials used for gaskets are not within the scope of this part of ISO 7005.

### 4.3 Bolting

The materials of the bolting shall be chosen by the user according to the pressure, flange material and the selected gasket so that the flanged joint remains tight under the expected operating conditions.

#### NOTES

- 1 For the purposes of this part of ISO 7005, either metric or inch bolting may be used for ISO PN20 and ISO PN50 flanges in conjunction with gaskets manufactured from sheet materials.
- 2 For flange types 01, 05 (when it is copper alloy only), 11, 12, 14 and 21, where copper alloy bolting is used, the recommended bolting materials are ISO 428 I/28A or I/28B for temperatures up to and including 120 °C. (See table 11 for an explanation of the abbreviated alloy designations.)
- 3 For flange types 02, 04, 05 (when it is ferrous with copper alloy cladding) and 07, ferrous bolting should be used and reference should be made to ISO 7005-1.

## 5 Dimensions

### 5.1 Range of nominal sizes

The range of nominal sizes applicable to each flange type and to each pressure rating shall be as specified in table 2.

NOTE — The sizes of copper and copper alloy tubes are designated by reference to the outside diameter in millimetres.

### 5.2 Dimensional details

Dimensions of flanges shall be in accordance with the following tables, as appropriate:

- table 3 for ISO PN6 flanges
- table 4 for ISO PN10 flanges
- table 5 for ISO PN16 flanges
- table 6 for ISO PN20 flanges
- table 7 for ISO PN25 flanges
- table 8 for ISO PN40 flanges
- table 9 for ISO PN50 flanges

#### NOTES

- 1 The bore sizes of type 21 flanges are usually equal to the nominal size of the pipe, valve or fitting of which they form a part and the actual bore sizes are usually given in the appropriate product standard.
- 2 Where type 07, 12 and 14 flanges are for use with soft soldering techniques only, then reference should be made to ISO 2016 for socket depths.
- 3 For type 04 and 11 flanges the recommended weld preparation angle is  $37,5^\circ \pm 2,5^\circ$  when butt welding to pipe with thicknesses of 3 mm and greater.

## 6 Joint facings and surface finish

**6.1** Types 01, 11, 12, 14 and 21 flanges shall be supplied with flat faces for use with full-face gaskets.

#### NOTES

- 1 Notes at the foot of table 3 (ISO PN6), table 4 (ISO PN10), table 5 (ISO PN16) and table 7 (ISO PN25) indicate which sizes may be used in conjunction with inside bolt circle gaskets and type 02, 04, 05 and 07 flanges.
- 2 Where type 21 flanges in table 3 (ISO PN6), table 4 (ISO PN10), table 5 (ISO PN16) and table 7 (ISO PN25) in sizes up to and including DN 100 are required for bolting to flanges with raised faces, then the appropriate flange thickness ( $C_1^*$ ) given in table 8 (ISO PN40) applies.

**6.2** Where type 01, 11, 12 and 14 flanges in sizes above DN 50, and type 21 flanges in sizes above DN 100 are required to be bolted to existing raised face type steel or cast iron flanges, then the raised faces shall be removed.

**6.3** Where type 01, 11, 12, 14 and 21 flanges for ISO PN20 and ISO PN50 are required to be bolted to existing raised face type steel or cast iron flanges, then the raised faces on all sizes shall be removed.

**6.4** All flange jointing faces shall be finished in accordance with table 1. The faces shall be compared by visual or tactile means with reference specimens which conform to the  $R_a$  and  $R_z$  values given in table 1.

#### NOTES

- 1 It is not intended that instrument measurements are taken on the flange faces, and the  $R_a$  and  $R_z$  values as defined in ISO 468 relate to the reference specimens.
- 2 Other finishes may be agreed between the manufacturer and purchaser.

**Table 1.— Surface finish of flanges**

Values in micrometres

Manufacturing process	$R_a$	$R_z$
Turning <sup>1)</sup>	3,2 to 12,5	12,5 to 50
Other <sup>2)</sup>	3,2 to 6,3	12,5 to 25

- 1) "Turning" covers any method of machine operation producing either serrated concentric or serrated spiral grooves.
- 2) Processes other than turning are permissible provided that they give a surface finish in compliance with the  $R_a$  and  $R_z$  values specified.

**6.5** Flange rims are permitted to be machined or left unmachined.

**6.6** Composite flanges shall be machine finished, or have a surface equivalent to that obtained by machining on all locating diameters, bores and abutment faces. The abutment faces shall be flat and square to the bore axis.

## 7 Drilling and spot-facing

**7.1** Unless otherwise specified by the purchaser, all bolt holes shall be equally spaced on the pitch circle diameter,  $K$ . In the case of integral flanges, the bolt holes shall be positioned off-centre.

**7.2** Bearing surfaces for the nuts shall be parallel to the flange jointing face within  $1^\circ$  and shall be capable of accepting a normal series washer complying with the requirements of ISO 887.

**7.3** Any back-facing or spot-facing required to accomplish this shall not reduce the flange thickness to less than the minimum specified.

**7.4** When a bossed or integral flange is back-faced, it is permissible for the fillet to be reduced but the fillet shall not be eliminated entirely.

## 8 Tolerances

Flanges shall be manufactured to comply with the tolerances specified in table 12.

## 9 Marking

Flanges other than integral shall be clearly marked as follows:

- a) the nominal size (DN) and the nominal pressure rating (ISO PN);
- b) material designation (for copper alloy and ferrous material designations, see table 11);
- c) manufacturer's name or trademark.

*Examples:*

Copper alloy component:  
**DN 300 ISO PN20 1/29A XXXX**  
(e.g. for CuNi10Fe1Mn)

Ferrous component:  
**DN 300 ISO PN20 A105 XXXX**

Copper alloy flanges shall be clearly and permanently marked by vibro or electrolytic etching or by other suitable means. Stamping with steel stamps shall not be used. The manufacturer's name or trademark together with other relevant marking may be produced during casting or forging operations.

NOTE — Ferrous flanges may be marked round the rim of the flange using round-nosed steel stamps.

## 10 Inspection and test

ISO PN20 and ISO PN50 flanges specified are designed to be interchangeable with, but not identical to, comparable flanges to ANSI B16.24.

## NOTES

1 It is recommended that these flanges be accepted by inspectors as complying with the dimensions specified in ANSI B16.24.

2 This part of ISO 7005 does not make provision for routine inspection or pressure testing of separate flanges. However, flanges may be required to be pressure tested after attachment to a pipe or other equipment. The test pressure is then dependent on the requirements of the appropriate standard or code of practice in accordance with which the equipment has been manufactured (see the annex).

## 11 Information to be supplied by the purchaser

The following information should be supplied by the purchaser in the enquiry and/or order:

- a) number of this part of ISO 7005, i.e. ISO 7005-3;
- b) nominal size — DN followed by the appropriate number;
- c) nominal pressure — ISO PN followed by the appropriate number;
- d) flange type number (and whether thicker flanges are required; see 6.1);
- e) material designations (for both the copper alloy and the ferrous component, where applicable);
- f) any protective coating (galvanizing, painting) of the ferrous flanges, subject to agreement between the purchaser and manufacturer;
- g) whether flange rims are to be machined or unmachined (see 6.5);
- h) the bore of the flange and/or collar where flanges can be made to suit more than one tube diameter (see tables 3 to 9).

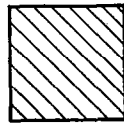

Copper alloy component

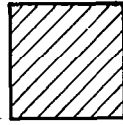

Ferrous component



**Type 01**  
Plate flange for brazing or welding

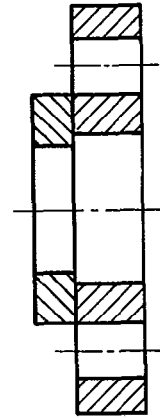

**Type 02**  
Loose flange with plate collar for brazing or welding

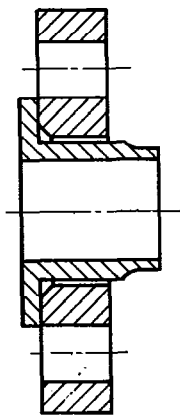

**Type 04**  
Loose flange with welding neck collar for welding

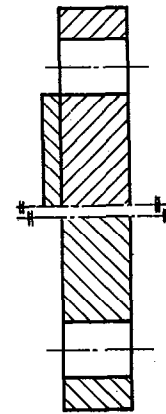

**Type 05**  
Blank flange

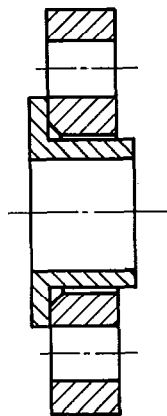

**Type 07**  
Loose flange with slip-on collar for soft soldering, brazing, or welding

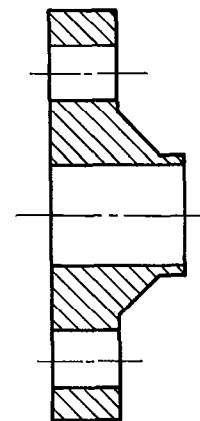

**Type 11**  
Welding neck flange

**Figure 1 — Types of flanges**



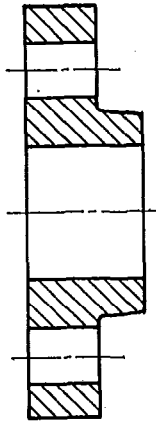

**Type 12**  
Hubbed slip-on flange for soft soldering,  
brazing or welding

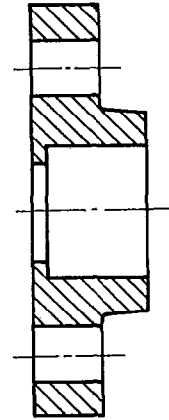

**Type 14**  
Hubbed slip-on flange for soft soldering,  
brazing or welding with tube-stops

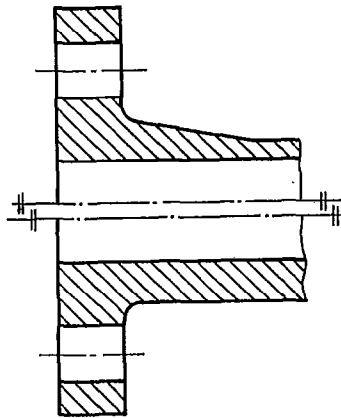

**Type 21**  
Integral flange

**Figure 1 – Types of flanges (concluded)**



Type 05

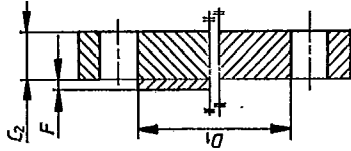

Type 04

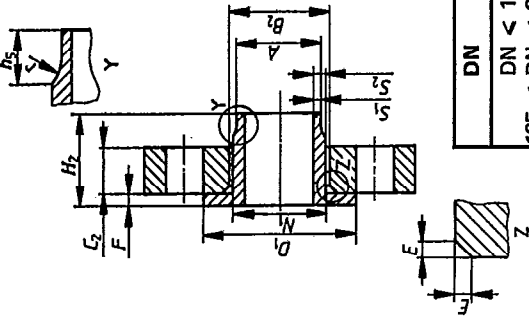

DN	h <sub>5</sub>	r
DN < 100	15	3
125 < DN < 250	15	5
300 < DN < 350	16	5
400 < DN < 450	16	7
500 < DN < 600	20	7
700 < DN < 800	24	7

Type 01

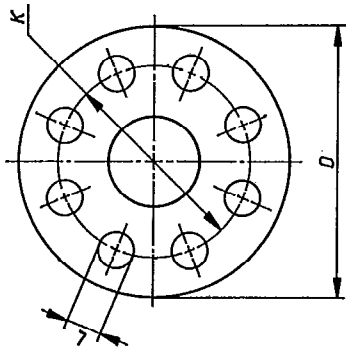
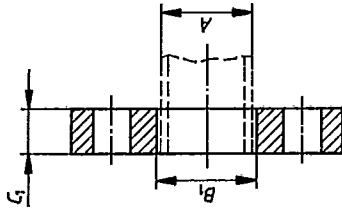

This diagram illustrates the arrangement but not necessarily the correct number of bolt holes.

Refer to the column "number of bolts" in table 3 for the actual number.

Type 21

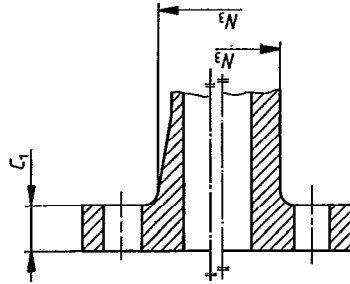

Type 14

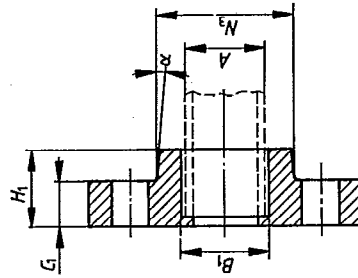

Type 12

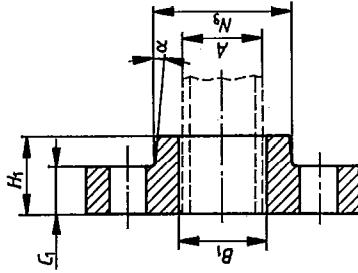

Type 07

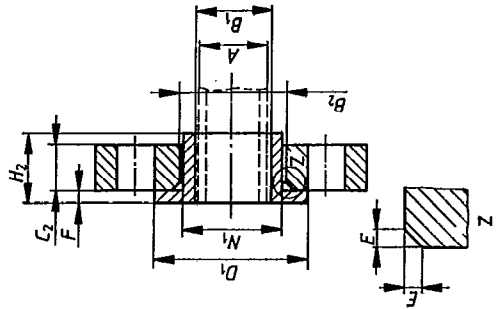

Dimensions in millimetres

Table 3 — Dimensions of ISO PN6 flanges

Nominal size	Mating dimensions				Tube outside diameter	DN	Flange thickness		Hub diameter	Neck diameter	Collar diameter		Length through hub or collar		Collar thickness		Collar flange thickness	Cladding thickness	Collar or raised face diameter		Bore of flange or collar		Bore of flange		Chamfer					
	Outside diameter of flange	Diameter of bolt circle	Diameter of bolt holes	Number			Nominal size of bolts	C <sub>1</sub>			C <sub>2</sub>	N <sub>3</sub>	N <sub>1</sub>	H <sub>1</sub>	H <sub>2</sub>	S <sub>1min</sub>			S <sub>2</sub>	F	D <sub>1</sub>	01 07	12 14	04		05 07	04	07	04	07
10	15	16	50	11	4	M10	10	6	21	16	18	21	10	35	16	1	2	5	33	15,07	16,07	19	23	E						
15	18	20	55	11	4	M10	10	6	26	21	22	26	10	35	16	1	2	5	38	18,07	20,08	24	28	2						
20	22	25	65	11	4	M10	10	6	31	28	27	31	10	40	16	1,5	2,5	5	48	22,08	25,08	28	33	3						
25	28	30	75	11	4	M10	12	8	36	35	32	36	12	40	18	1,5	2,5	5	58	28,08	30,08	33	38	3						
32	35	38	90	14	4	M12	12	8	45	42	40	45	12	40	18	1,5	2,5	5	69	35,09	38,08	41	47	3						
40	42	44,5	100	14	4	M12	12	9	51	52	46,5	51	13	45	19	1,5	2,5	5	78	42,09	44,6	48	53	3						
50	54	57	110	14	4	M12	12	11	67	64	59	67	15	45	19	1,5	2,5	6	88	54,09	57,23	62	69	3						
65	76,1	81	130	14	4	M12	12	13	87	79	78	87	17	45	19	2	3,5	6	108	76,33	81	89	3							
80	88,9	94	150	18	4	M16	14	13	104	94	91	104	17	50	21	2,5	4	6	124	89,13	94	106	3							
100	108	116	170	18	4	M16	14	16	123	116	110	123	20	50	21	2,5	4	6	144	108,38	113	125	3							
125	133	148	200	18	8	M16	14	18	148	155	135	148	22	50	21	2,5	4	6	174	133,63	138	151	4							
150	159	180	225	18	8	M16	14	18	175	180	161	175	24	50	21	2,5	4	8	199	159,63	164	178	4							
175	193,7	209	295	18	8	M16	18	20	209	209	196	210	26	50	23	3	4,5	8	229	194,63	200	213	5							
200	219,1	234	320	18	8	M16	18	20	235	234	221	235	28	50	23	3	4,5	8	254	220,03	225	238	5							
250	267/273	286	375	18	12	M16	20	22	285	286	269/275	285/291	30	50	27	3	4,5	8	309	268,13/274,13	278/284	288/296	5/7							
300	323,9	336	440	22	12	M20	24	24	342	336	326	342	30	50	30	4	5,5	10	363	325,03	330	345	7							
350	368	390	490	22	12	M20	26	26	386	390	370	386	30	50	32	4	5,5	10	413	369,13	374	389	7							
400	419	442	540	22	16	M20	30	28	439	442	421	439	30	50	36	4	5,5	10	463	420,13	426	442	7							
450	457,2	477	595	22	16	M20	32	24	477	492	459	477	32	50	38	4	5,5	10	518	458,33	465	480	7							
500	508	530	600	22	20	M20	32	24	530	546	510	530	33	50	47	4,5	6	10	568	509,13	516	533	7							
600	610	646	705	26	20	M24	36	30	637	646	612	637	60	50	5	6,5	14	5	667	612	619	639	9							
700	711	748	810	26	24	M24	40	32	741	748	713	741	60	55	6	7,5	14	5	772	713	721	743	9							
800	813	852	920	30	24	M27	44	34	844	852	815	844	60	60	6	7,5	14	5	878	815	824	846	9							
900	914	954	1 020	30	24	M27	48	36	948	954	918	948	65	65	—	—	—	5	978	916	—	960	9							
1 000	1 016	1 054	1 175	30	28	M27	52	40	1 051	1 054	1 018	1 051	70	70	—	—	—	5	1 078	1 018	—	1 050	9							
1 200	1 220	1 260	1 405	33	32	M30	60	40	1 259	1 260	1 222	1 259	80	80	—	—	—	5	1 295	1 222	—	1 262	9							
1 400	1 420	1 466	1 560	36	36	M33	66	44	1 465	1 466	1 422	1 465	88	88	—	—	—	5	1 510	1 422	—	1 468	9							
1 600	1 620	1 672	1 830	36	40	M33	74	48	1 669	1 672	1 636	1 669	98	98	—	—	—	5	1 710	1 622	—	1 672	9							
1 800	1 820	1 876	2 045	39	44	M36	84	50	1 873	1 876	1 840	1 873	110	110	—	—	—	5	1 918	1 822	—	1 876	9							

NOTES

- For type 21 flanges in sizes up to and including DN 100 and type 12 (and 14) flanges up to and including DN 50 for bolting to flanges with raised faces, the appropriate thickness (C<sub>1</sub>\*) in table 8 (ISO PN40) shall apply. (See 6.1.)
- Type 21 flanges in sizes DN 125 to DN 1 800 may be used with inside bolt circle gaskets and type 04, 05 and 07 flanges. (See 6.2.)
- For type 12 and type 14 flanges of all nominal sizes, α = 4° max.
- Dimension E is given for information only.

Type 05

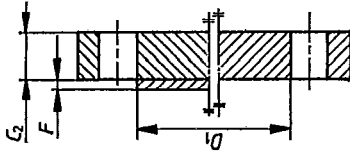

Type 04

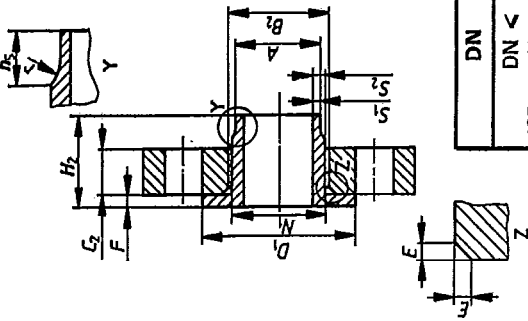

DN	r	h <sub>2</sub>
DN < 100	3	15
DN < 250	5	15
DN < 350	5	16
DN < 450	7	16
DN < 600	7	20
DN < 800	7	24
DN < 1 200	7	32

Type 01

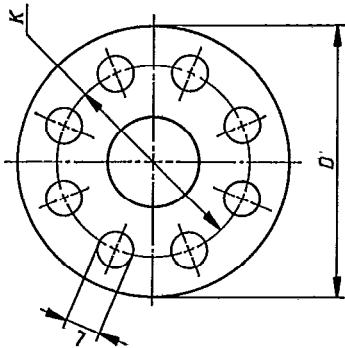
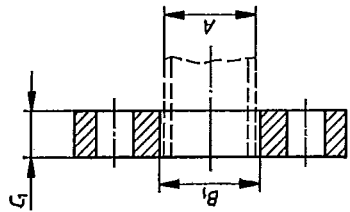

This diagram illustrates the arrangement but not necessarily the correct number of bolt holes.

Refer to the column "number of bolts" in table 4 for the actual number.

Type 21

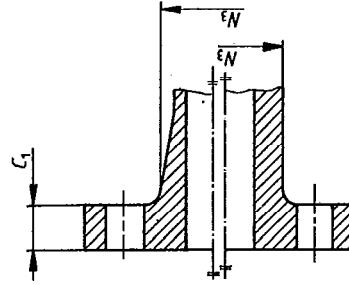

Type 14

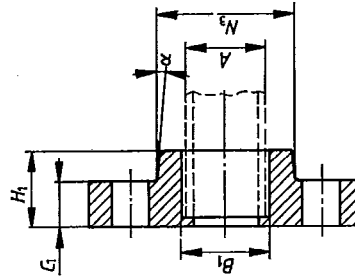

Type 12

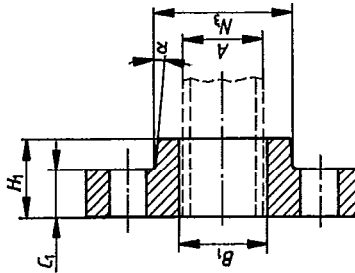

Type 07

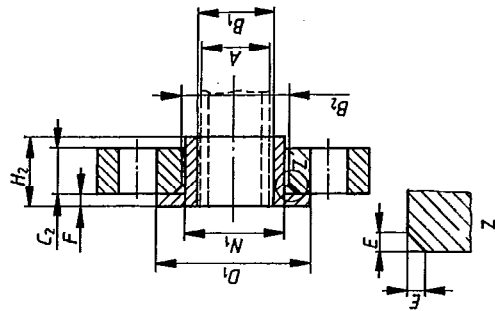

Dimensions in millimetres

Table 4 — Dimensions of ISO PN10 flanges

DN	Mating dimensions				Tube outside diameter	Flange thickness	Hub diameter	Neck diameter	Collar diameter		Length through hub or collar	Collar thickness		Collar flange thickness	Cladding thickness	Collar or raised face diameter	Bore of flange or collar		Bore of flange	Chamfer								
	Outside diameter of flange	Diameter of bolt circle	Diameter of bolt holes	Number					Nominal size of bolts	C <sub>1</sub>		N <sub>3</sub>	N <sub>1</sub>				H <sub>1</sub>	H <sub>2</sub>			S <sub>1min</sub>	S <sub>2</sub>	F	F <sub>min</sub>	D <sub>1</sub>	B <sub>1</sub>	B <sub>2</sub>	E
10	90	60	14	4	M12	8	16	18	21	20	35	16	1	2	5	41	15,07	19	23	2								
15	95	65	14	4	M12	8	21	22	26	20	35	16	1	2	5	46	18,07	24	28	2								
20	105	75	14	4	M12	8	31	27	31	24	40	16	1,5	2,5	5	56	22,08	28	33	3								
25	115	85	14	4	M12	9	35	32	36	24	40	18	1,5	2,5	5	65	28,08	33	38	3								
32	140	100	18	4	M16	10	42	40	45	26	40	18	1,5	2,5	5	76	35,09	41	47	3								
40	150	110	18	4	M16	11	51	46,5	51	26	45	19	1,5	2,5	5	84	42,09	48	53	3								
50	165	125	18	4	M16	13	67	59	67	28	45	19	1,5	2,5	5	99	54,09	62	69	3								
65	185	145	18	4	M16	13	87	78	87	17	45	19	2	3,5	5	118	76,33	81	89	3								
80	200	160	18	8	M16	13	104	91	104	17	50	21	2,5	4	5	132	89,13	94	106	3								
100	220	180	18	8	M16	16	123	110	123	20	50	21	2,5	4	5	156	108,38	113	125	3								
125	250	210	18	8	M16	18	148	135	148	22	50	21	2,5	4	5	184	133,63	138	151	4								
150	285	240	22	8	M20	18	175	161	175	24	50	21	2,5	4	5	211	159,63	164	178	4								
175	315	270	22	8	M20	20	210	196	210	26	50	23	3	4,5	5	242	194,63	200	213	5								
200	340	295	22	8	M20	24	235	221	235	28	50	23	3	4,5	5	266	220,03	225	238	5								
250	395	350	22	12	M20	26	285	269/275	285/291	30	50	27	3	4,5	5	319	268,13/274,13	278/284	288/296	5/7								
300	445	400	22	12	M20	26	342	326	342	30	50	30	4	5,5	5	370	325,03	330	345	7								
350	505	460	22	16	M20	28	386	370	386	30	50	32	4	5,5	5	429	369,13	374	389	7								
400	565	515	26	16	M24	32	439	421	439	30	50	36	4	5,5	5	480	420,13	426	442	7								
450	615	565	26	20	M24	34	488	459	477	32	50	38	4,5	6	5	530	458,33	465	480	7								
500	670	620	26	20	M24	38	552	510	530	33	50	42	5	6,5	5	582	509,13	516	533	7								
600	780	725	30	20	M27	38	647	612	637	49	60	50	6	7,5	5	629	612	619	639	9								
700	895	840	30	24	M27	40	751	713	741	53	60	55	6,5	9,5	5	733	713	727	743	9								
800	1 015	950	33	24	M30	44	866	815	844	55	60	60	7,5	10,5	5	836	815	829	846	9								
900	1 115	1 050	33	28	M30	48	970	918	948	—	60	65	8,5	11,5	5	940	916	931	950	9								
1 000	1 230	1 160	36	28	M33	52	—	1 076	1 051	—	60	70	9	—	5	1 043	1 018	1 025	1 053	9								
1 200	1 455	1 380	39	32	M36	60	—	1 284	1 259	—	60	80	11	—	5	1 251	1 222	1 230	1 262	9								
1 400	1 675	1 590	42	36	M39	—	—	1 494	1 465	—	—	—	—	—	5	1 457	1 422	—	1 468	9								
1 600	1 915	1 820	48	40	M45	—	—	1 702	1 669	—	—	—	—	—	5	1 661	1 622	—	1 672	9								
1 800	2 115	2 020	48	44	M45	—	—	1 906	1 873	—	—	—	—	—	5	1 865	1 822	—	1 875	9								

NOTES

- For type 21 flanges in sizes up to and including DN 100 and type 12 (and 14) flanges up to and including DN 50 for bolting to flanges with raised faces, the appropriate thickness (C<sub>1</sub>\*) in table 8 (ISO PN40) shall apply. (See 6.1.)
- Type 21 flanges in sizes DN 125 to DN 1 800 may be used with inside bolt circle gaskets and type 04, 05 and 07 flanges. (See 6.2.)
- For type 12 and type 14 flanges of all nominal sizes, α = 4° max.
- Dimension E is given for information only.

Type 05

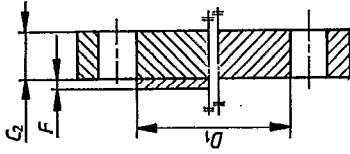

Type 04

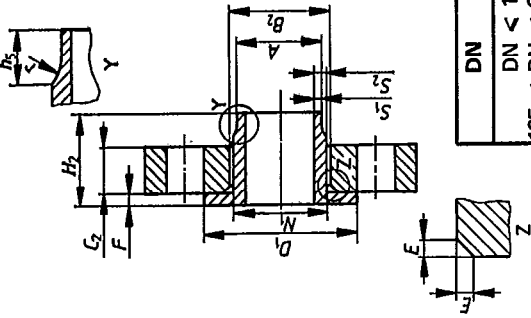

DN	$h_5$	r
DN < 100	15	3
125 < DN < 250	15	5
300 < DN < 350	16	5
DN = 400	16	7

Type 01

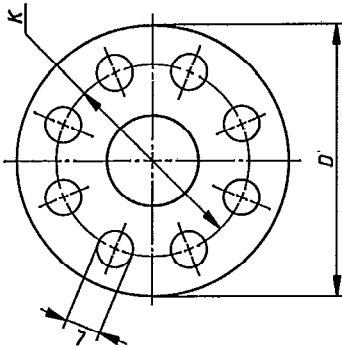
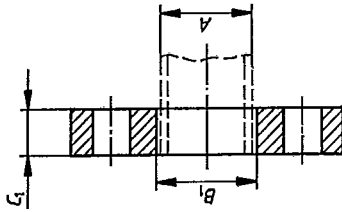

This diagram illustrates the arrangement but not necessarily the correct number of bolt holes.

Refer to the column "number of bolts" in table 5 for the actual number.

Type 21

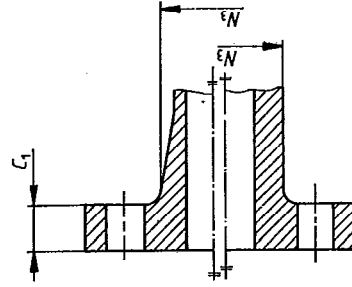

Type 14

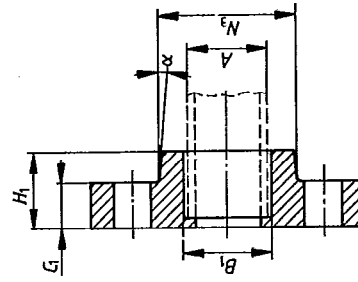

Type 12

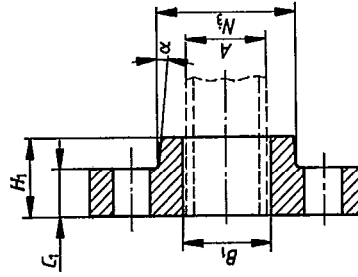

Type 07

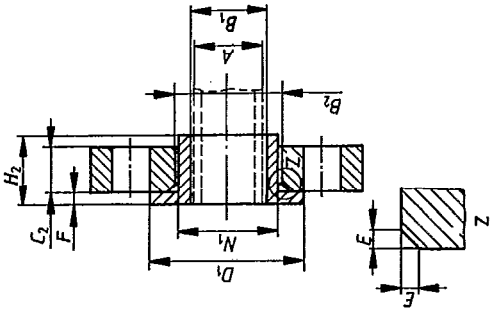

Table 5 — Dimensions of ISO PN16 flanges

Dimensions in millimetres

Nominal size	Tube outside diameter	Mating dimensions				Flange thickness		Hub diameter		Neck diameter		Collar diameter		Length through hub or collar		Collar thickness			Collar flange thickness		Cladding thickness		Collar or raised face diameter		Bore of flange or collar			Bore of flange		Chamfer							
		Outside diameter of flange	Diameter of bolt circle	Diameter of bolt holes	Number	Nominal size of bolts	C <sub>2</sub>	C <sub>1</sub>	N <sub>3</sub>	N <sub>1</sub>	H <sub>1</sub>	H <sub>2</sub>	S <sub>1min</sub>	S <sub>2</sub>	F	D <sub>1</sub>	B <sub>1</sub>		B <sub>2</sub>	E	C <sub>2</sub>	C <sub>1</sub>	D <sub>1</sub>	D <sub>2</sub>	D <sub>3</sub>	D <sub>4</sub>	D <sub>5</sub>	D <sub>6</sub>	D <sub>7</sub>								
																	04	07													01	07	04	05	07		
DN	A	D	K	L		C <sub>2</sub>	C <sub>1</sub>	N <sub>3</sub>	N <sub>1</sub>	H <sub>1</sub>	H <sub>2</sub>	S <sub>1min</sub>	S <sub>2</sub>	F	D <sub>1</sub>	B <sub>1</sub>	B <sub>2</sub>	E		C <sub>2</sub>	C <sub>1</sub>	D <sub>1</sub>	D <sub>2</sub>	D <sub>3</sub>	D <sub>4</sub>	D <sub>5</sub>	D <sub>6</sub>	D <sub>7</sub>									
10	15	90	60	14	4	M12	8	6	16	21	16	1	2,5	5	41	15,07	16,07	19	23	2																	
15	18	95	65	14	4	M12	8	6	21	26	21	1	2,5	5	46	18,07	20,08	24	28	2																	
20	22	105	75	14	4	M12	8	6	28	31	28	1,5	2,5	5	56	22,08	25,08	28	33	3																	
25	28	115	85	14	4	M12	9	8	35	36	35	1,5	2,5	5	65	28,08	30,08	33	38	3																	
32	35	140	100	18	4	M16	10	8	45	45	42	1,5	2,5	5	76	35,09	38,08	41	47	3																	
40	42	150	110	18	4	M16	11	9	51	51	52	1,5	2,5	6	84	42,09	44,6	48	53	3																	
50	54	165	125	18	4	M16	13	11	67	64	64	1,5	2,5	6	99	54,09	57,23	62	69	3																	
65	76,1	185	145	18	4	M16	16	13	103	79	87	2	3,5	6	118	76,33		81	89	3																	
80	88,9	200	160	18	8	M16	18	13	114	94	104	2,5	4	7	132	89,13		94	106	3																	
100	100	220	180	18	8	M16	18	16	134	116	123	2,5	4	7	156	108,38		113	125	3																	
125	133	250	210	18	8	M16	18	22	164	159	148	2,5	4	7	184	133,63		138	151	4																	
150	159	285	240	22	8	M20	18	22	188	184	175	2,5	4	9	211	159,63		164	178	4																	
175	193,7	315	270	22	8	M20	22	24	210	211	210	3	4,5	9	242	194,63		200	213	5																	
200	219,1	340	295	22	12	M20	22	26	238	236	235	4	4,5	9	266	220,03		225	238	5																	
250	267/273	405	355	26	12	M24	24	28	287	290	285/291	4	4,5	9	319	268,13/274,13		278/284	288/296	5/7																	
300	323,9	460	410	26	12	M24	28	—	312	—	—	5	6,5	11	370	325,03		330	—	7																	
350	368	520	470	26	16	M24	32	—	336	—	—	6	7,5	11	429	369,13		374	—	7																	
400	419	580	525	30	16	M27	36	—	448	—	—	7,5	9	12	480	420,13		426	—	7																	
500	508	715	650	33	20	M30	—	—	552	—	—	—	—	—	—	—		—	—	—																	

NOTES

- For type 21 flanges in sizes up to and including DN 100 and type 12 (and 14) flanges up to and including DN 50 for bolting to flanges with raised faces, the appropriate thickness (C<sub>1</sub>\*) in table 8 (ISO PN40) shall apply. (See 6.1.)
- Type 21 flanges in sizes DN 125 to DN 250 and type 12 (and 14) flanges in sizes DN 65 to DN 250 may be used with inside bolt circle gaskets and type 04, 05 and 07 flanges. (See 6.2.)
- For type 12 and type 14 flanges of all nominal sizes, α = 4° max.
- Dimension E is given for information only.



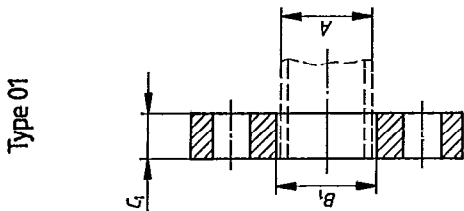
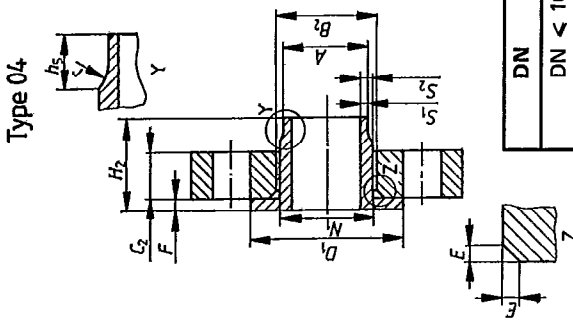
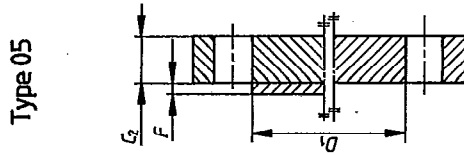
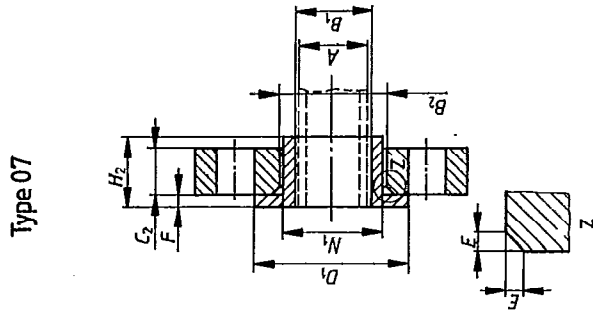

DN	r	h <sub>5</sub>
DN < 100	3	15
DN < 250	5	15
300 < DN < 350	5	16
400 < DN < 450	7	16
500 < DN < 600	7	20
700 < DN < 800	7	24
DN = 900	7	32

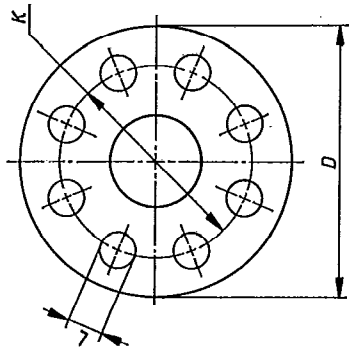

This diagram illustrates the arrangement but not necessarily the correct number of bolt holes.

Refer to the column "number of bolts" in table 6 for the actual number.

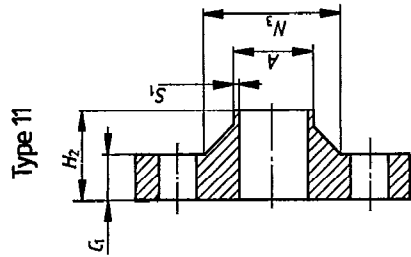
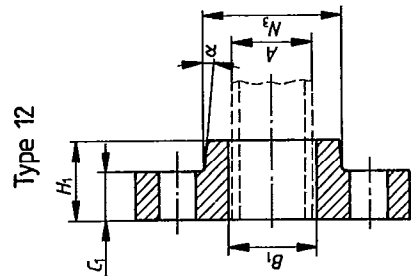
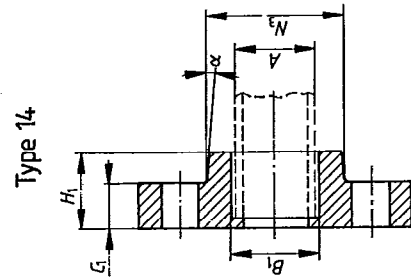
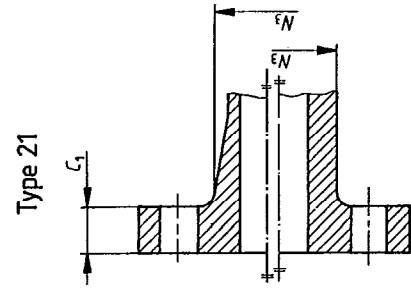

Table 6 — Dimensions of ISO PN20 flanges

Dimensions in millimetres

Nominal size	Mating dimensions				Flange type												Inner flange collar thickness	Inner collar wall thickness	Cladding thickness	Collar or raised face diameter	Bore of flange or collar	Bore of backing flange	Chamfer							
	Tube outside diameter	Outside diameter of flange	Diameter of bolt circle	Diameter of bolt holes	Number	Nominal size of bolts	Flange thickness		Hub diameter		Neck diameter	Collar diameter	Length through hub or collar		S <sub>1min</sub>	S <sub>2min</sub>								F		D <sub>1</sub>	B <sub>1</sub>		B <sub>2</sub>	E
							C <sub>2</sub>	C <sub>1</sub>	11	12			04	07										H <sub>1</sub>	H <sub>2</sub>		04	07		
10	16	90	60,5	16	4	M14	11,1	8	21	30	18	21	35	16	48	1	2	5	40	16,07	19	23	2							
20	25	100	70	16	4	M14	12,7	8	31	38	27	31	40	16	52	1	2,5	5	53	25,08	28	33	2							
25	30	110	79,5	16	4	M14	14,3	9	36	49	32	36	40	18	56	1,5	2,5	5	60	30,08	33	38	3							
32	38	120	89	16	4	M14	15,4	10	45	59	40	45	40	18	57	1,5	2,5	5	70	38,08	41	47	3							
40	44,5	130	98,5	16	4	M14	17,5	11	51	65	46,5	51	45	19	62	1,5	2,5	5	80	46,6	48	53	3							
50	57	150	120,5	18	4	M16	19	13	67	78	59	67	45	19	64	1,5	2,5	6	99	57,23	62	69	3							
65	76,1	180	139,5	18	4	M16	23,8	20	85	90	78	87	45	19	70	2	3	5	120	76,33	81	89	3							
80	88,9	190	152,5	18	4	M16	24	20	103	108	91	94	50	19	70	2,5	3,5	5	130	89,18	94	99	3							
100	108	230	190,5	18	8	M16	24	20	134	135	110	110	50	—	76	2,5	3,5	7	188	108,38	113	—	3							
125	133	255	216	22	8	M20	24,4	22	159	164	135,5	135	50	—	89	2,5	3,5	5	188	133,63	138	—	4							
150	159	280	241,5	22	8	M20	25,5	22	183	192	161,5	161,5	50	—	89	2,5	3,5	5	212	159,63	164	—	4							
200	219,1	345	298,5	22	8	M20	29	26	238	246	222	222	50	—	102	3,5	5	268	220,03	225	—	5								
250	267/273	405	362	26	12	M24	30,5	28	287	305	269/275	269	60	—	102	4	5,5	320	268,13/274,13	278	—	5/7								
300	323,9	485	432	26	12	M24	32	40	344	365	327	327	60	—	114	5	6,5	370	325,03	330	—	7								
350	368	535	476	29,5	12	M27	35	41	395	—	371	371	50	—	127	5,5	7	430	369,13	374	—	7								
400	419	600	540	29,5	16	M30	37	45	446	—	422	422	50	—	127	6	7,5	462	420,13	426	—	7								
450	457,2	635	578	32,5	16	M30	40	48	508	—	460	460	50	—	140	7	8,5	530	458,33	465	—	7								
500	508	700	635	32,5	20	M30	45	49	559	—	511	511	50	—	144	7,5	9	585	509,13	517	—	7								
600	610	815	749,5	35,5	20	M33	48	50	665	—	613	613	60	—	152	9	10,5	685	611,13	618	—	9								
700	711	925	863	35,5	28	M33	72	52	775	—	719	719	60	—	152	10,5	14,5	800	712,13	727	—	9								
800	813	1 060	978	42	28	M39	81	56	879	—	821	821	60	—	144	12	16	905	814,13	829	—	9								
900	914	1 170	1 086	42	32	M39	90,5	60	988	—	921	921	60	—	157	13,5	17,5	1 000	915,13	921	—	9								

NOTES

- For type 12 and type 14 flanges of all nominal sizes,  $\alpha = 4^\circ$  max.
- Dimension E is given for information only.

Type 05

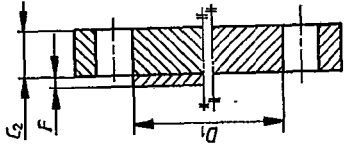

Type 04

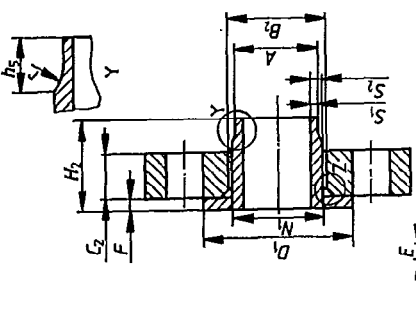

DN	h <sub>5</sub>	r
DN < 100	15	3
DN < 250	15	5
125 < DN < 300	16	5

Type 02

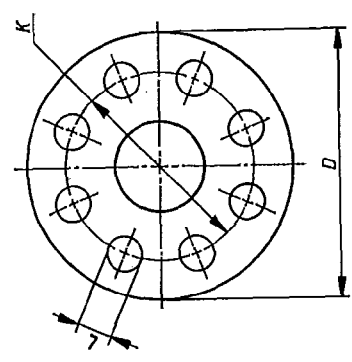
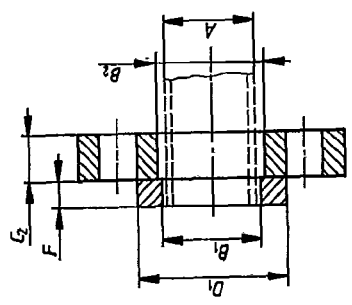

This diagram illustrates the arrangement but not necessarily the correct number of bolt holes.  
Refer to the column "number of bolts" in table 7 for the actual number.

Type 21

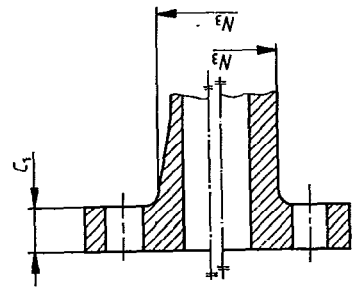

Type 14

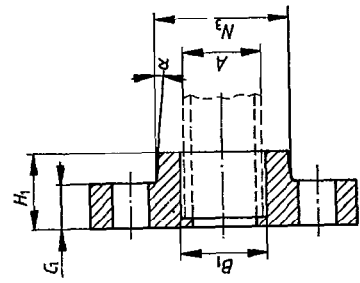

Type 12

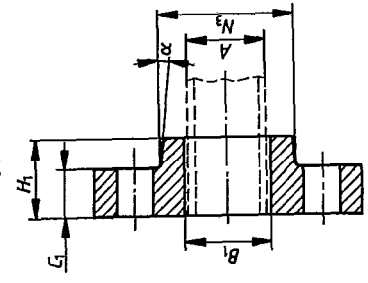

Table 7 – Dimensions of ISO PN25 flanges

Dimensions in millimetres

Nominal size  DN	Tube outside diameter  A		Mating dimensions				Flange thickness	Hub diameter	Neck diameter	Collar diameter	Length through hub or collar	Collar thickness	Collar flange thickness	Cladding thickness	Collar or raised face diameter	Bore of flange or collar	Bore of flange	Chamfer																	
			Outside diameter of flange  D	Diameter of bolt circle  K	Diameter of bolt holes  L	Bolts													Flange type																
						Number													Nominal size of bolts	02 04 05	12 14	21 14	12 21	04	12 14	04	04	02 04 05	04 05	02 04 05	12 14	02 04	04		
			C <sub>2</sub>	C <sub>1</sub>	N <sub>3</sub>	N <sub>1</sub>													H <sub>1</sub>	H <sub>2</sub>	S <sub>1min</sub>	S <sub>2min</sub>	F	D <sub>1</sub>	B <sub>1</sub>		B <sub>2</sub>	E							
10	15	16	90	60	14	4	M12	16	8	21	16	18	20	35	1,5	2,5	12	5	5	40	15,07	16,07	18	2											
15	18	20	95	65	14	4	M12	16	8	26	21	22	20	35	1,5	2,5	12	5	5	45	18,07	20,08	22	2											
20	22	25	105	75	14	4	M12	16	8	31	28	27	24	40	1,5	2,5	14	5	5	58	22,08	25,08	28	3											
25	28	30	115	85	14	4	M12	18	9	36	35	32	24	40	1,5	2,5	14	5	5	68	28,08	30,08	33	3											
32	35	38	140	100	18	4	M16	18	10	9	45	42	40	26	40	1,5	2,5	14	5	5	78	35,09	38,08	42	3										
40	42	44,5	150	110	18	4	M16	18	11	51	52	46,5	26	45	1,5	2,5	14	6	5	88	42,09	44,6	50	3											
50	54	57	165	125	18	4	M16	20	13	11	67	64	59	28	45	2	3	16	6	5	102	54,09	57,23	62	3										
65	76,1	185	145	18	8	M16	20	22	13	103	79	78	32	45	2,5	4	16	6	5	122	76,33	81	3												
80	88,9	200	160	18	8	M16	22	24	14	114	94	91	34	50	3,5	4,5	18	7	5	138	89,13	94	3												
100	108	235	190	22	8	M20	22	26	17	137	116	110	40	50	4	5	20	7	5	162	108,38	113	3												
125	133	270	220	26	8	M24	24	26	160	165	135,5	44	50	5	6,3	22	7	5	188	133,63	138	4													
150	159	300	250	26	8	M24	24	28	26	186	192	161,5	48	50	5	6,3	22	9	5	218	159,63	164	4												
175	193,7	330	280	26	12	M24	—	28	216	217	197	50	—	4	5,5	23	9	—	—	194,63	200	5													
200	219,1	360	310	26	12	M24	26	30	246	246	222	50	50	6	7,5	24	9	5	278	220,03	225	5													
250	267/273	425	370	30	12	M27	30	32	296	295	269/275	54	50	7	8,5	26	9	5	335	268,13/274,13	278	5/7													
300	323,9	485	430	30	16	M27	34	—	32	—	348	327	—	50	8	9,5	28	11	5	395	325,03	329	7												
350	368	555	490	33	16	M30	38	—	36	—	404	—	—	—	—	—	32	—	5	450	369,13	374	—												
400	419	620	550	36	16	M33	42	—	38	—	458	—	—	—	—	—	34	—	5	505	420,13	426	—												
500	508	730	660	36	20	M33	50	—	42	—	564	—	—	—	—	—	38	—	5	615	509,13	517	—												

NOTES

- For type 21 flanges in sizes up to and including DN 100 and type 12 (and 14) flanges up to and including DN 50 for bolting to flanges with raised faces, the appropriate thickness (C<sub>1</sub>\*) in table 8 (ISO PN40) shall apply. (See 6.1.)
- Type 21 flanges in sizes DN 125 to DN 250 and type 12 (and 14) flanges in sizes DN 65 to DN 250 may be used with inside bolt circle gaskets and type 02, 04, 05 and 07 flanges. (See 6.2.)
- For type 12 and type 14 flanges of all nominal sizes,  $\alpha = 4^\circ$  max.
- Dimension E is given for information only.

Type 21

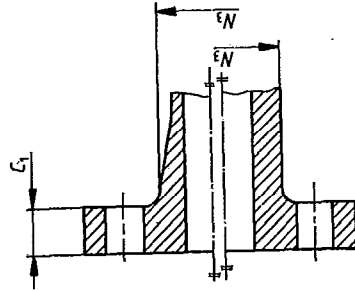

Type 05

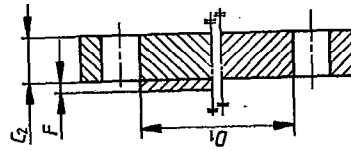

Type 02

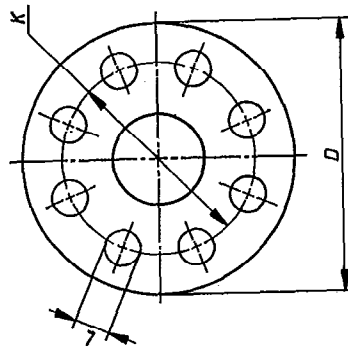
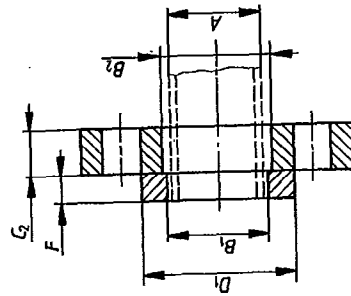

This diagram illustrates the arrangement but not necessarily the correct number of bolt holes.

Refer to the column "number of bolts" in table 8 for the actual number.

Table 8 — Dimensions of ISO PN40 flanges

Dimensions in millimetres

Nominal size  DN	Tube outside diameter  A	Mating dimensions					Flange thickness	Neck diameter	Collar flange thickness	Cladding thickness	Collar or raised face diameter	Bore of flange or collar	Bore of flange									
		Outside diameter of flange  D	Diameter of bolt circle  K	Diameter of bolt holes  L	Bolts									Flange type								
					Number	Nominal size of bolts								02	21		21	02	05	02	02	02
														05	C <sub>1</sub>	C <sub>1</sub> *	N <sub>3</sub>	F		D <sub>1</sub>	B <sub>1</sub>	B <sub>2</sub>
10	16	90	60	14	4	M12	16	9	12	16	12	5	40	16,07	18							
15	20	95	65	14	4	M12	16	9	12	21	12	5	45	20,08	22							
20	25	105	75	14	4	M12	16	9	12	28	14	5	58	25,08	28							
25	30	115	85	14	4	M12	18	11	14	35	14	5	68	30,08	33							
32	38	140	100	18	4	M16	18	11	15	42	14	5	78	38,1	42							
40	44,5	150	110	18	4	M16	18	13	16	52	14	5	88	44,6	50							
50	57	165	125	18	4	M16	20	13	17	64	16	5	102	57,23	62							
65	76,1	185	145	18	8	M16	20	14	17	79	16	5	122	76,33	81							
80	88,9	200	160	18	8	M16	22	16	19	94	18	5	138	89,13	94							
100	108	235	190	22	8	M20	22	19	21	116	20	5	162	108,38	113							
125	133	270	220	26	8	M24	24	—	—	—	22	5	188	133,63	138							
150	159	300	250	26	8	M24	24	—	—	—	22	5	218	159,63	164							
200	219,1	375	320	30	12	M27	30	—	—	—	26	5	285	220,03	225							
250	267/273	450	385	33	12	M30	36	—	—	—	30	5	345	268,13/274,13	278							
300	323,9	515	450	33	16	M30	40	—	—	—	34	5	410	325,03	329							
350	368	580	510	36	16	M33	46	—	—	—	38	5	465	369,13	374							
400	419	660	585	39	16	M36	50	—	—	—	42	5	535	420,13	426							

NOTE — Type 21 C<sub>1</sub>\* thicknesses shall be used when required with a raised face of 1,6 mm or when required to be used with inside bolt circle gaskets or type 04, 05 and 07 flanges. (See 6.1.)

Type 07

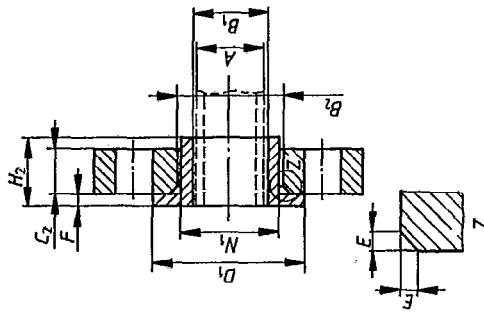

Type 05

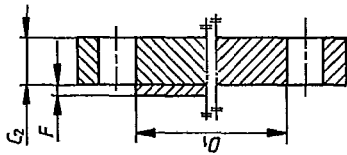

Type 04

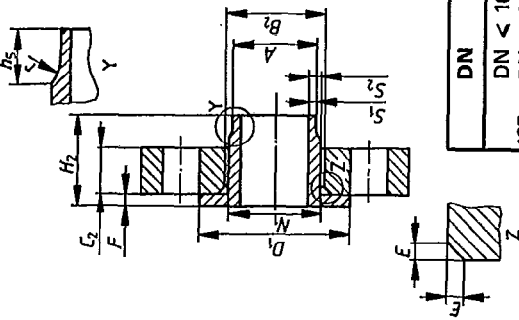

DN	$h_5$	r
DN < 100	15	3
DN < 250	15	5
125 < DN < 350	16	5
300 < DN < 450	16	7
400 < DN < 600	20	7

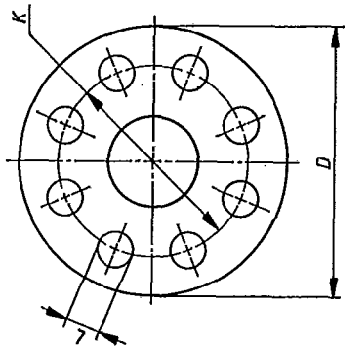

This diagram illustrates the arrangement but not necessarily the correct number of bolt holes.

Refer to the column "number of bolts" in table 9 for the actual number.

Type 21

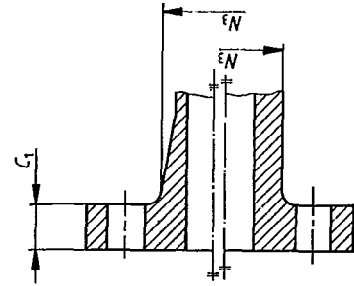

Type 14

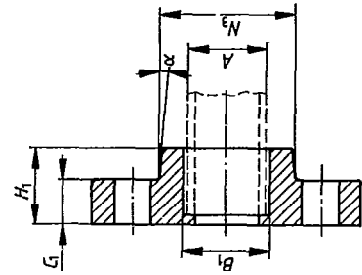

Type 12

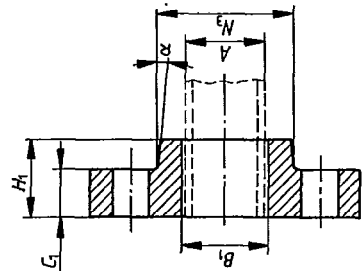

Type 11

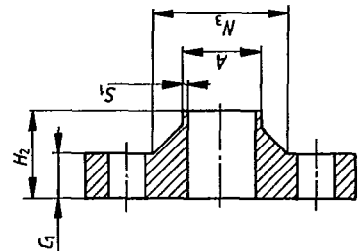

Table 9 — Dimensions of ISO PN50 flanges

Dimensions in millimetres

Nominal size	Tube outside diameter	Mating dimensions				Flange type												Bore of flange or collar	Bore of backing flange	Chamfer									
		Outside diameter of flange	Diameter of bolt circle	Diameter of bolt holes	Number	Nominal size of bolts	Flange thickness		Hub diameter		Neck diameter	Collar diameter	Length through hub or collar		Inner collar flange thickness	Inner flange collar thickness	Cladding thickness				Collar or raised face diameter	Bore of flange or collar		Bore of backing flange					
							C <sub>2</sub>	C <sub>1</sub>	N <sub>3</sub>	N <sub>1</sub>			H <sub>1</sub>	H <sub>2</sub>								S <sub>1min</sub>	S <sub>2min</sub>		F	D <sub>1</sub>	B <sub>1</sub>	B <sub>2</sub>	E
DN	A	D	K	L		04	07	11	12	14	21	04	07	11	04	04	04	05	07	07	12	14	04	07	04	07	04	07	E
10	16	95	66,5	16	4	M14	14,5	9	13	21	30	18	21	35	52	1,5	2	5	40	16,07	19	23	2	2	19	23	2	2	2
20	25	120	82,5	18	4	M16	16	11	13	31	38	27	31	40	57	1,5	2,5	5	58	25,08	28	33	2	2	28	33	2	2	2
25	30	125	89	18	4	M16	17,5	11	15	36	49	32	36	40	62	1,5	2,5	5	68	30,08	33	38	3	3	33	38	3	3	3
32	38	135	98,5	18	4	M16	19,5	12	16	45	59	40	45	20	65	1,5	2,5	5	78	38,08	41,5	47	3	3	41,5	47	3	3	3
40	44,5	155	114,5	22	4	M20	21	13	18	51	65	46,5	51	28	68	1,5	2,5	6	88	46,6	48	53	3	3	48	53	3	3	3
50	57	165	127	18	8	M16	22,5	13	19	67	78	59	67	28	70	2	3	6	102	57,23	62	69	3	3	62	69	3	3	3
65	76,1	190	149	22	8	M20	25,5	22	21	103	90	78	86	32	76	2,5	3,5	6	122	76,33	81	89	3	3	81	89	3	3	3
80	88,9	210	168,5	22	8	M20	29	24	23	114	108	91	—	36	79	2,5	3,5	7	138	89,18	94	—	3	3	94	—	3	3	3
100	108	255	200	22	8	M20	32	26	27	137	135	110	—	40	86	3	4	7	158	108,38	113	—	4	4	113	—	4	4	4
125	133	280	235	22	8	M20	35	26	28	160	164	135,5	—	44	98	3	4	7	188	133,63	138,5	—	4	4	138,5	—	4	4	4
150	159	320	270	22	12	M20	37	28	30	186	192	161,5	—	48	98	3,5	4,5	9	212	159,63	164	—	4	4	164	—	4	4	4
200	219,1	380	330	26	12	M24	41,5	30	35	246	246	222	—	50	111	4,5	6	9	268	220,03	225	—	5	5	225	—	5	5	5
250	267/273	445	387,5	29,5	16	M27	48	36	—	296	—	269/275	—	58	117	5,5	7	9	320	268,13/274,13	278	—	5	5	278	—	5	5	5
300	323,9	520	451	32,5	16	M30	51	42	—	360	—	327	—	68	130	7	8,5	11	370	325,03	330	—	7	7	330	—	7	7	7
350	368	585	514,5	32,5	20	M30	54	46	—	430	—	371	—	78	143	8	9,5	11	430	369,13	374	—	7	7	374	—	7	7	7
400	419	650	571,5	35,5	20	M33	57,5	52	—	480	—	422	—	82	146	9	10,5	12	482	420,13	426	—	7	7	426	—	7	7	7
450	457,2	715	628,5	35,5	24	M33	60,5	54	—	540	—	460	—	86	159	9,5	11	12	530	458,33	465	—	7	7	465	—	7	7	7
500	508	775	686	35,5	24	M33	63,5	56	—	595	—	511	—	90	162	11	12,5	14	585	509,13	517	—	7	7	517	—	7	7	7
600	610	915	813	42	24	M39	70	58	—	710	—	613	—	105	168	13	14,5	14	685	611,13	618	—	9	9	618	—	9	9	9

NOTES

- 1 For type 12 and type 14 flanges of all nominal sizes,  $\alpha = 4^\circ$  max.
- 2 Dimension *E* is given for information only.



**Table 10 — Pressure/temperature (p/T) ratings— General application**

Nominal pressure ISO PN	Temperature, °C								
	- 10 to 65	100	120 <sup>1)</sup>	150	180	200 <sup>2)</sup>	220	250	260
	Maximum permissible working pressure, bar <sup>3)</sup> (gauge)								
6	6	6	6	6	6	5	4	2,5	2
10	10	10	10	10	10	8,5	7	5	4
16	16	16	16	16	16	13,5	11,3	8	7
20 <sup>4)</sup>	15,5	14,6	13,9	13,3	12,4	11,8	11,3	10,7	10,3
25	25	25	25	25	25	21,2	17,5	12,2	10,5
40	40	40	40	38,5	34	30	25,5	19,5	17,5
50 <sup>4)</sup>	34,4	32,3	31,1	29,3	27,4	26,2	24,9	23,1	22,4

1) ISO PN6, ISO PN10, ISO PN16, ISO PN25 and ISO PN40 flanges larger than DN 250 are limited to a maximum temperature of 120 °C.

2) Flanges in alloy I/26A are limited to a maximum temperature of 200 °C.

3) 1 bar = 0,1 MPa

4) Table 10 does not apply to ISO PN20 flanges larger than DN 300 and ISO PN50 flanges larger than DN 200 [see table 10b)].

**Table 10a) — Pressure/temperature ratings applicable to ISO alloys I/38D and I/29B only**

Nominal pressure ISO PN	Temperature, °C												
	- 10 to 65	100	120 <sup>1)</sup>	150	180	200	220	250	260	280	300	320	350
	Maximum permissible working pressure, bar <sup>2)</sup> (gauge)												
6	6	6	6	6	6	5,5	5	4,5	4	3,5	3	2,5	2
10	10	10	10	10	10	9,5	8,5	7,5	7	6,5	6	5	4
16	16	16	16	16	16	15	14	13	12	11	10	8,5	7
20 <sup>3)</sup>	15,5	15	14,5	14	13,7	13,5	13	12,7	12,5	12	11,5	11	10,3
25	25	25	25	25	25	24	22	19	18,5	16,5	14,5	13	10,5
40	40	40	40	38,5	35,5	33,5	31	28	26,5	24,5	22,5	20,5	17,5
50 <sup>3)</sup>	34,4	33	32,5	30,5	29	28,5	27,5	26,5	26	25	24,5	23,5	22,4

1) ISO PN6, ISO PN10, ISO PN16, ISO PN25 and ISO PN40 flanges larger than DN 250 are limited to a maximum temperature of 120 °C.

2) 1 bar = 0,1 MPa

3) Table 10a) does not apply to ISO PN20 flanges larger than DN 300 and ISO PN50 flanges larger than DN 200 [see table 10b)].

**Table 10b) — Pressure/temperature ratings — ISO PN20 and ISO PN50 flanges (large sizes).<sup>1)</sup>**

Nominal pressure ISO PN	Temperature, °C	
	- 20 to 100	120
	Maximum permissible pressure, bar <sup>2)</sup> (gauge)	
20	14	13,9
50	20	19,8

1) Table 10b) is applicable to ISO PN20 flanges in nominal sizes DN 350 to DN 900 and to ISO PN50 flanges in nominal sizes DN 250 to DN 600.

2) 1 bar = 0,1 MPa

**Table 10c) — Pressure/temperature ratings applicable to ISO alloy I/38A for ISO PN20 and ISO PN50 flanges<sup>1)</sup>**

Nominal pressure ISO PN	Temperature, °C						
	- 10 to 65	100	120	150	180	200	220
	Maximum permissible pressure, bar <sup>2)</sup> (gauge)						
20	15,5	14,3	13,4	12,4	11,2	10,6	9,8
50	34,4	31,3	29,3	26,9	23,8	22,1	20,2

1) Table 10c) does not apply to ISO PN20 and ISO PN50 flanges larger than DN 300 [see table 10b)].

2) 1 bar = 0,1 MPa

## 12 Limitations for flanges attached by soft solder or silver brazing

ISO PN6, ISO PN10, ISO PN16, ISO PN20, ISO PN25 and ISO PN50 flanges used in conjunction with copper tubes to ISO 274 up to and including DN 50 and attached by soft solder shall be limited to the following maximum operating temperatures and/or pressures:

6 bar at 110 °C

10 bar at 65 °C

16 bar at 30 °C

For all flanges attached by silver brazing to copper alloy tubes the maximum operating temperature shall not exceed 200 °C.

Table 11 – Copper alloy materials

Copper alloy standard	Form	Abbreviated alloy designation <sup>1)</sup>	Methods of attachment		
			Soft solder <sup>2)</sup>	Silver brazing	Fusion welding
			Slip-on	Slip-on	Slip-on or butt welded
ASTM B61 : UNS C92200 ISO 1338: CuPb5Sn5Zn5 CuSn8Pb2 CuAl10Fe3 CuAl10Fe5Ni5	Cast	C922	X	X	
		I/38A	X	X	
		I/38B	X	X	
		I/38C			X
		I/38D			X
ISO 426-1: CuZn20Al2 ISO 428: CuAl10Fe3 CuAl10Ni5Fe4 ISO 429: CuNi10Fe1Mn CuNi30Mn1Fe	Forged	I/26A		X	X
		I/28A			X
		I/28B			X
		I/29A		X	X
		I/29B		X	X

1) Owing to the length of ISO copper alloy designations, the abbreviated form shall be used.

2) Applicable to attachment to copper tubes to ISO 274 and appropriate to sizes up to and including DN 50.

Table 11a) – Ferrous materials

Form	Ferrous alloy standard
Plate (for composite and clad blank flanges)	ISO 630: Fe360B
Forging (for composite and clad blank flanges)	ASTM A105

Table 12 — Tolerances

Dimensions and tolerances in millimetres

Symbol reference	Feature	Type	DN																																				
			50	65	80	100	125	150	175	200	250	300	350	400	450	500	600	700	800	900	1 000	1 200	1 400	1 600	1 800														
			Tolerances																																				
B <sub>1</sub>	Bore diameter	01 <sup>1)</sup>	+0,05 0			+0,1 0			+0,25 0																														
			+1,5 0			+2 0																																	
		02 <sup>1)</sup>	+0,05 0			+0,1 0			+0,25 0																														
			+1,5 0			+2 0																																	
		B <sub>2</sub>	02	+1 0			+1,5 0			+2 0																													
			04	+1 0			+1,5 0			+2 0																			+4 0										
		B <sub>1</sub>	07 <sup>1)</sup>	+0,05 0			+0,1 0			+0,25 0																			+3 0										
+1,5 0				+2 0																																			
B <sub>2</sub>	07	+1 0			+1,5 0			+2 0			+4 0																												
B <sub>1</sub>	12 <sup>1)</sup> 14 <sup>1)</sup>	+0,05 0			+0,1 0			+0,25 0			+3 0																												
		+1,5 0			+2 0																																		
H <sub>2</sub>	Length through hub or collar	04	±1,5			±2																																	
		07	+1,5 0			+2,5 0			+3,5 0																														
H <sub>1</sub>	12;14	+1,5 0			+2,5 0			+3,5 0																															
N <sub>1</sub>	Hub, neck or collar diameter	04	±0,5			±1			±1,5			±2																											
		07	±0,5			±1			±2			±3			±4																								
N <sub>3</sub>		12;14	±0,5			±1			±2			±3			±4																								
		21	+1,5			+2,5			+3,5			+5			+10																								
D	Outside diameter of flange	All machined	±1			±1,5			±2			±2																											
		unmachined	±2			±2			±3			±5																											
C <sub>1</sub> , C <sub>2</sub>	Flange thickness	C <sub>1</sub> : 01; 11; 12; 14; 21 C <sub>2</sub> : 02; 04; 05; 07	C <sub>1</sub> , C <sub>2</sub> < 25			25 < C <sub>1</sub> , C <sub>2</sub> < 50			50 < C <sub>1</sub> , C <sub>2</sub> < 75			C <sub>1</sub> , C <sub>2</sub> > 75																											
			+3,5 0			+5 0			+7,5 0			+10 0																											
D <sub>1</sub>	Collar or raised face diameter	02	+1 0			+2 0			+3 0																														
		04	±1			±2																																	
		05	±1			±2																	±3																
		07	+1 0			+2 0			+3 0																														
F	Facing height	02	±0,5			±1																																	
		04	+0,5			±1																				±1,5													
		05	±0,3			±0,63																																	
		07	+1 0			+2 0																				+3 0													
K	Pitch circle diameter	All	M12 to M24 ±0,9			M27 to M45 ±1,4																																	
	Centre to centre	All	±0,45			±0,7																																	
	Eccentricity	As given	< DN 100 ±1			> DN 125 ±2																																	
L	Bolt hole diameter	All	< 20 +0,5 0			> 22 +1 0																																	
—	Bolt bearing surfaces shall be parallel to the flange jointing face as follows: machined: ±1° unmachined: ±2°																																						

1) Types 01, 02, 07, 12 and 14 can be attached by soldering (up to DN 50), silver brazing or fusion welding. The smaller tolerances shall be used for soldering and brazing.

## NOTES TO TABLE 12

- 1 The tolerances are applicable to ISO PN6, ISO PN10, ISO PN16, ISO PN25 and ISO PN40 only.
- 2 The eccentricity given is between  $K$  and any machined diameter.
- 3 Miscellaneous radii chamfers should be regarded as maxima unless otherwise specified. Tolerances on the pitch circle diameter and centre-to-centre of adjacent bolt holes are determined by the differences between the bolt and the bolt hole diameter which, in conjunction, cannot exceed the clearance together with any tolerance on the diameter of the bolt hole.

## Bibliography

The following publications are referred to in this part of ISO 7005.

ISO 274, *Copper tubes of circular section — Dimensions.*

ISO 426-1, *Wrought copper-zinc alloys — Chemical composition and forms of wrought products — Part 1: Non-leaded and special copper-zinc alloys.*

ISO 428, *Wrought copper-aluminium alloys — Chemical composition and forms of wrought products.*

ISO 429, *Wrought copper-nickel alloys — Chemical composition and forms of wrought products.*

ISO 468, *Surface roughness — Parameters, their values and general rules for specifying requirements.*

ISO 630, *Structural steels.*

ISO 887, *Plain washers for metric bolts, screws and nuts — General plan.*

ISO 1338, *Cast copper alloys — Composition and mechanical properties.*

ISO 2016, *Capillary solder fittings for copper tubes — Assembly dimensions and tests.*

ISO 6708, *Pipe components — Definition of nominal size.*

ISO 7268, *Pipe components — Definition of nominal pressure.*

ANSI B16.24, *Bronze pipe flanges and flanged fittings, Class 150 and 300.*

ASTM A105, *Forged carbon steel.*

ASTM B61, *Steam or valve bronze castings.*

## Annex

### Application and installation

(This annex does not form an integral part of the standard.)

**A.1** When using bolting materials other than copper alloy the purchaser should take into account the pressure, flange material and the related gasket so that the joint remains tight under the expected operating conditions.

**A.2** Application of the ratings to flanged joints at either high or low temperature should consider the effect of the risk of leakage due to forces and movement developed in the connecting pipes.

**A.3** Flanges may be required to be pressure tested after attachment of a pipe or other equipment or when forming an integral part of such equipment. The test pressure is then dependent on the requirements of the appropriate standard or code of practice in accordance with which the equipment has been fabricated or manufactured. Any test pressure should not exceed 1,5 times the allowable pressure at 20 °C, rounded up to the next whole bar increment.

---

**ISO 7005-3 : 1988 (E)**

---

**UDC 621.643.412 : 669.35**

**Descriptors :** metal tubes, pipe joints, copper products, pipe flanges, specifications, dimensions, marking.

Price based on 26 pages

---