**Natural gas — Determination of
mercury —**

Part 2:

**Sampling of mercury by amalgamation on
gold/platinum alloy**

Gaz naturel — Détermination de la teneur en mercure —

*Partie 2: Échantillonnage du mercure par amalgamation sur alliage
or/platine*



PDF disclaimer

This PDF file may contain embedded typefaces. In accordance with Adobe's licensing policy, this file may be printed or viewed but shall not be edited unless the typefaces which are embedded are licensed to and installed on the computer performing the editing. In downloading this file, parties accept therein the responsibility of not infringing Adobe's licensing policy. The ISO Central Secretariat accepts no liability in this area.

Adobe is a trademark of Adobe Systems Incorporated.

Details of the software products used to create this PDF file can be found in the General Info relative to the file; the PDF-creation parameters were optimized for printing. Every care has been taken to ensure that the file is suitable for use by ISO member bodies. In the unlikely event that a problem relating to it is found, please inform the Central Secretariat at the address given below.

© ISO 2003

All rights reserved. Unless otherwise specified, no part of this publication may be reproduced or utilized in any form or by any means, electronic or mechanical, including photocopying and microfilm, without permission in writing from either ISO at the address below or ISO's member body in the country of the requester.

ISO copyright office
Case postale 56 • CH-1211 Geneva 20
Tel. + 41 22 749 01 11
Fax + 41 22 749 09 47
E-mail copyright@iso.org
Web www.iso.org

Published in Switzerland

Contents

Page

Foreword	iv
Introduction	v
1 Scope	1
2 Normative references	1
3 Terms and definitions	1
4 Principle	1
5 Apparatus	2
6 Reagents and materials	8
7 Preparation of sampling and analytical tubes	9
7.1 Filling	9
7.2 Cleaning	9
7.3 Efficiency testing	9
8 Sampling	9
8.1 General	9
8.2 Conditions for representative sampling	10
8.3 Sampling procedure at atmospheric pressure (see Figure 1)	10
8.4 Sampling procedure at high pressure (see Figure 4)	11
8.5 Removal of condensate from discarded sampling tubes	12
9 Mercury determination	12
9.1 Transfer of mercury to the analytical tube (double amalgamation)	12
9.2 Transfer of mercury to AAS or AFS instrument	13
9.3 Calibration	13
9.4 Blank test	13
10 Calculation	13
11 Precision	16
12 Test report	16
Bibliography	17

Foreword

ISO (the International Organization for Standardization) is a worldwide federation of national standards bodies (ISO member bodies). The work of preparing International Standards is normally carried out through ISO technical committees. Each member body interested in a subject for which a technical committee has been established has the right to be represented on that committee. International organizations, governmental and non-governmental, in liaison with ISO, also take part in the work. ISO collaborates closely with the International Electrotechnical Commission (IEC) on all matters of electrotechnical standardization.

International Standards are drafted in accordance with the rules given in the ISO/IEC Directives, Part 2.

The main task of technical committees is to prepare International Standards. Draft International Standards adopted by the technical committees are circulated to the member bodies for voting. Publication as an International Standard requires approval by at least 75 % of the member bodies casting a vote.

Attention is drawn to the possibility that some of the elements of this document may be the subject of patent rights. ISO shall not be held responsible for identifying any or all such patent rights.

ISO 6978-2 was prepared by Technical Committee ISO/TC 193, *Natural gas*, Subcommittee SC 1, *Analysis of natural gas*.

This first edition of ISO 6978-2, together with ISO 6978-1, cancels and replaces ISO 6978:1992, which has been technically revised.

ISO 6978 consists of the following parts, under the general title *Natural gas — Determination of mercury*:

- *Part 1: Sampling of mercury by chemisorption on iodine*
- *Part 2: Sampling of mercury by amalgamation on gold/platinum alloy*

Introduction

Natural gases may contain considerable amounts of mercury, which are generally present in the elemental form. Gases with high mercury content have to be purified to avoid the condensation of mercury during processing and transport as well as to be compliant with the demands of gas sales contracts. Low mercury concentrations are specified when natural gas is to be liquefied. This is to avoid severe corrosion problems, for instance in aluminium heat exchangers of liquefaction plants.

Since the presence of hydrocarbons, in particular aromatic hydrocarbons present in low concentrations in almost every natural gas, interferes in the determination of mercury by atomic absorption spectrometry (AAS) or atomic fluorescence spectrometry (AFS), mercury cannot be determined directly in natural gas. Therefore, prior to the analytical determination, mercury has to be collected and separated from aromatic hydrocarbons.

The purpose of the determination of the mercury content can be

- to monitor gas quality,
- to monitor the operation of gas treatment plants for mercury removal.

Several methods for the collection or enrichment of mercury from natural gas have been developed. The collection of mercury from dry natural gas normally poses no particular problem. However, care should be taken when sampling mercury from natural gases under nearly condensing conditions (see ISO 6570).

The two parts of ISO 6978 describe the principles of sampling and specify the general requirements for methods for sampling mercury and for determining total mercury in pipeline quality natural gas. This part of ISO 6978 specifies a method of sampling mercury by amalgamation on gold/platinum alloy thread whereas Part 1 specifies a method of sampling mercury by chemisorption on iodine-impregnated silica gel.

Natural gas — Determination of mercury —

Part 2:

Sampling of mercury by amalgamation on gold/platinum alloy

WARNING — The use of this part of ISO 6978 may involve hazardous materials, operations and equipment. This part of ISO 6978 does not purport to address all of the safety problems, associated with its use. It is the responsibility of the user of this part of ISO 6978 to establish appropriate safety and health practices and to determine the applicability or regulatory limitations prior to use.

1 Scope

This part of ISO 6978 specifies a method for the determination of total mercury content of pipeline quality natural gas using a sampling method by amalgamation on gold/platinum (Au/Pt) alloy thread. This method is applicable to the sampling of raw natural gas when no condensation is present. At atmospheric pressure, this method is suitable for the determination of mercury content within the range of 0,01 $\mu\text{g}/\text{m}^3$ to 100 $\mu\text{g}/\text{m}^3$ in natural gas samples. At higher pressures (up to 8 MPa), this sampling method is suitable for the determination of mercury contents within the range of 0,001 $\mu\text{g}/\text{m}^3$ to 1 $\mu\text{g}/\text{m}^3$. The collected mercury is determined by measuring the absorbance or fluorescence of mercury vapour at 253,7 nm.

NOTE ISO 6978-1 gives a sampling method suitable for the determination of mercury contents in natural gas by chemisorption on iodine-impregnated silica gel for the working range of 0,1 $\mu\text{g}/\text{m}^3$ to 5 000 $\mu\text{g}/\text{m}^3$ for sampling at pressures up to 40 MPa.

2 Normative references

The following referenced documents are indispensable for the application of this document. For dated references, only the edition cited applies. For undated references, the latest edition of the referenced document (including any amendments) applies.

ISO 10715, *Natural gas — Sampling guidelines*

ISO 14532, *Natural gas — Vocabulary*

Guide to the expression of uncertainty in measurement (GUM), BIPM, IEC, IFCC, ISO, IUPAC, IUPAP, OIML

3 Terms and definitions

For the purposes of this document, the terms and definitions given in ISO 14532 apply.

4 Principle

Sampling is performed at a temperature at least 10 °C higher than the dewpoint of the gas sampled. The gas is passed through two quartz glass sampling tubes in series containing fine gold/platinum alloy thread. The mercury is collected on the gold/platinum alloy thread by amalgamation. Subsequently, each sampling tube is separately heated to 700 °C to desorb the mercury from the amalgam. The released mercury is transferred by

a stream of air onto an analytical tube filled with gold/platinum alloy thread (double amalgamation). This second quartz glass tube is then heated to 800 °C and the mercury is transferred to an AAS or AFS for measurement at 253,7 nm.

This sampling method is suitable for the determination of mercury content in natural gas in the range of 0,01 µg/m³ to 100 µg/m³ for sampling at atmospheric pressure and 0,001 µg/m³ to 1 µg/m³ for sampling at high pressure. To avoid diffusion of mercury from the surface into the gold/platinum alloy thread, which would reduce the recovery of mercury under the specified transfer conditions, it is necessary to determine the amount of collected mercury within one week after sampling.

Other sorption materials such as gold-impregnated silica with a high specific surface may be used instead of fine gold/platinum alloy thread, provided they show equivalent method performance in the natural gas matrix.

Unless otherwise specified, gas volumes are expressed in cubic metres (m³) at 273,15 K and 1 013,25 hPa.

NOTE The comparability of the two sampling techniques has been demonstrated by interlaboratory tests at two different concentration levels.

5 Apparatus

The parameters influencing the measurement shall be traceable to national or International Standards. The uncertainty of the volume measurement (volume, temperature and pressure of the gas as well as ambient air pressure) directly contributes to the uncertainty of the determined mercury content of the gas. Therefore suitable measuring equipment, calibrated against a commonly accepted reference, shall be used to minimize the uncertainty of the volume measurement to less than 1 %.

5.1 Sampling apparatus (see Figure 1).

5.1.1 Apparatus for sampling at atmospheric pressure, typically comprising the following:

5.1.1.1 Heated bypass valve.

5.1.1.2 Heated flow control valve (needle type).

5.1.1.3 Three-way valve, for the second bypass.

5.1.1.4 **Aluminium block**, capable of being heated to ≤ 100 °C (see Figure 2) and dividable into two halves with a central bore coated with a layer (about 2 mm) of silicon rubber for keeping the quartz glass sampling tubes filled with gold/platinum alloy thread (see Figure 3) during sampling at elevated temperature (if necessary) and equipped with a temperature gauge (not shown in Figure 1).

5.1.1.5 Flow meters (three):

— one for flowrates ≤ 50 l/min;

— two for flowrates ≤ 5 l/min.

5.1.1.6 **Gas meter**, suitable for measuring flowrates of ≤ 5 l/min, capable of allowing adjustment of the bypass flow and the volume measurement and equipped with the following:

a) **pressure gauge**;

b) **temperature gauge**, for measuring temperatures between 0 °C to 40 °C.

5.1.1.7 **Barometer**, required for measuring the ambient air pressure.

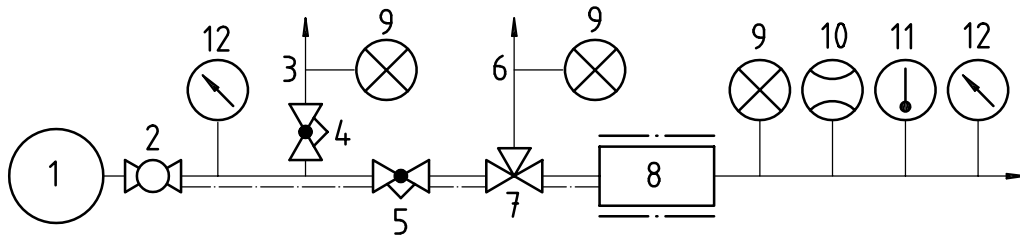

Key

- | | |
|----------------------|-------------------------------|
| 1 pipeline | 7 three-way valve |
| 2 sampling valve | 8 aluminium block for heating |
| 3 first bypass | 9 flow indicator |
| 4 bypass valve | 10 gas meter |
| 5 flow control valve | 11 temperature gauge |
| 6 second bypass | 12 pressure gauge |

Figure 1 — Sampling apparatus

Dimensions in millimetres

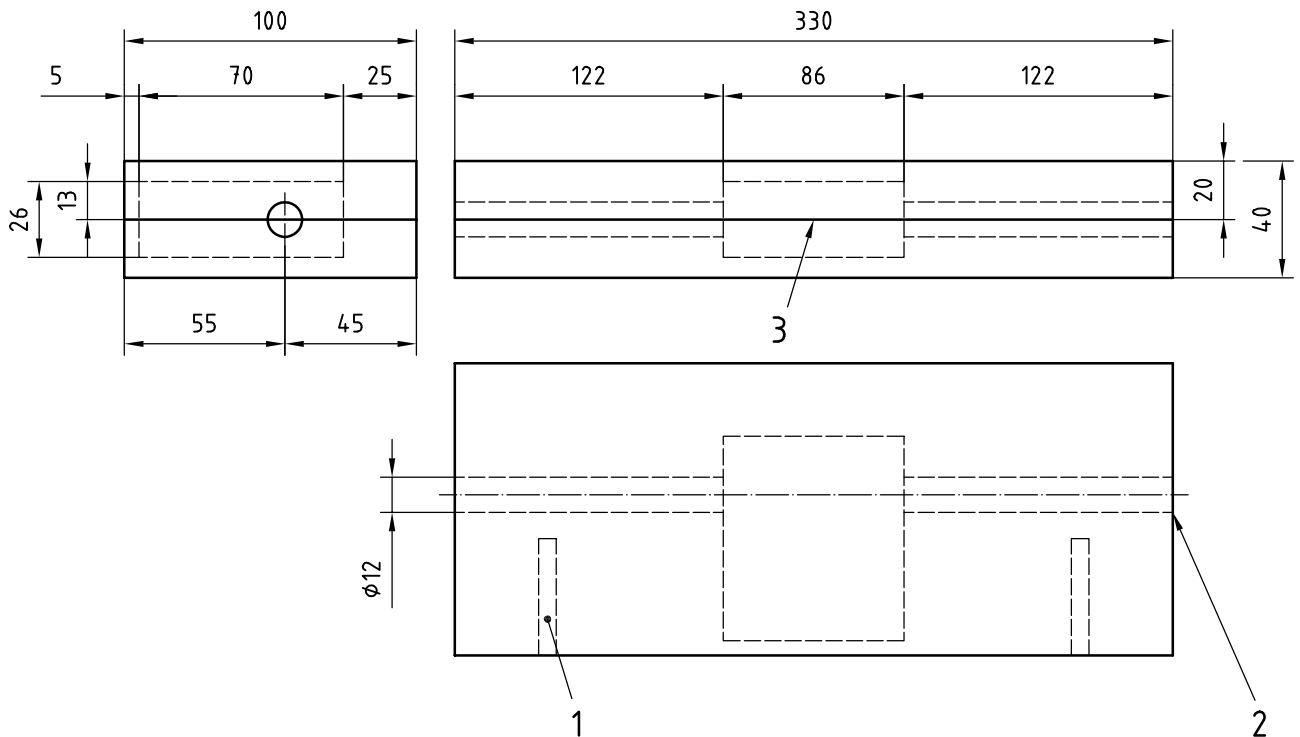

Key

- | |
|--------------------------|
| 1 heating plug |
| 2 silicon rubber (glued) |
| 3 division line |

Figure 2 — Heating box (heatable aluminium box)

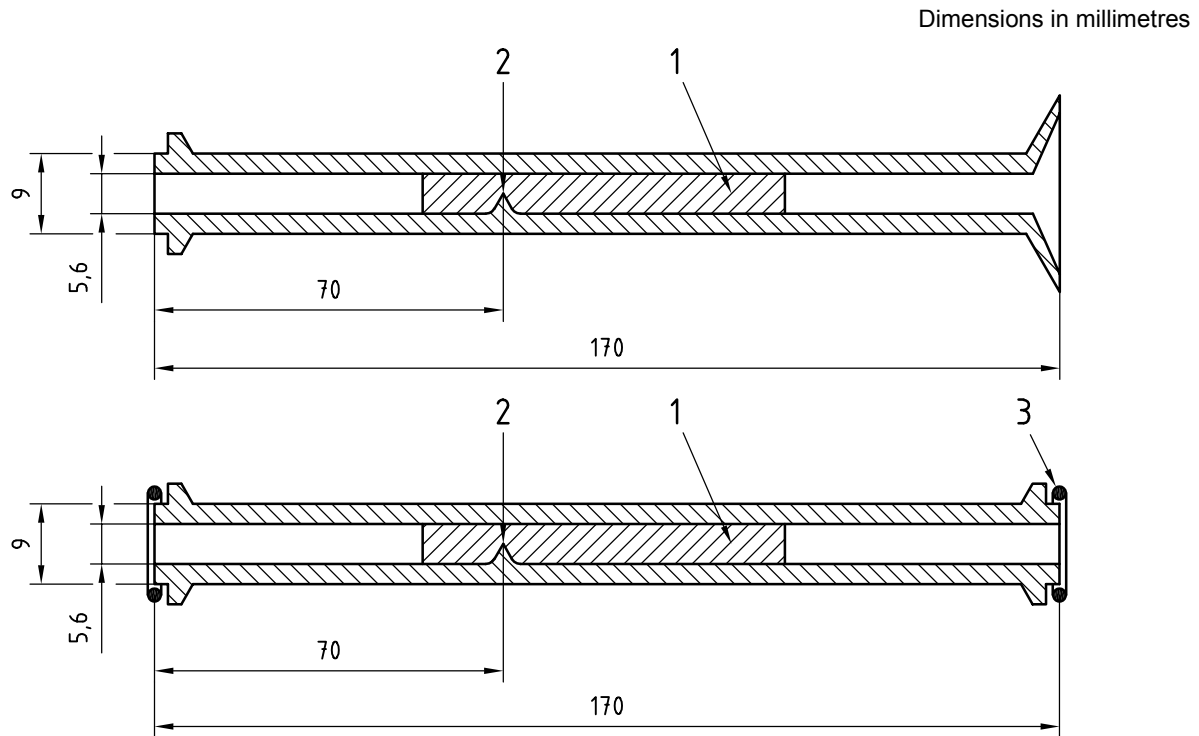

Key

- 1 gold/platinum wire (350 Au/150 Pt alloy)
- 2 indentation
- 3 O-ring

Figure 3 — Quartz glass sampling and analytical tubes

5.1.2 Apparatus for sampling at high pressure (see Figure 4), comprising the following:

5.1.2.1 Pressure gauge, suitable for measuring pressures from 0 MPa to 25 MPa.

5.1.2.2 Valve.

5.1.2.3 Bypass valve.

5.1.2.4 Pressure-reducing valves (two).

5.1.2.5 Three-way valve.

5.1.2.6 Pressure relief valves (two), set at pressures of 10 MPa and 4 kPa, respectively, to protect the high-pressure vessel and the gas meter against over pressure.

5.1.2.7 Pressure gauge, suitable for measuring pressures from 0 MPa to 10 MPa in the high-pressure vessel.

5.1.2.8 Flow indicator, for adjusting the gas flow through the high-pressure vessel.

5.1.2.9 Heating tape, for wrapping around the assembly except for the relieve valves and the flow indicator.

5.1.2.10 Gas meter, for measuring sample volumes and suitable for a gas flowrates of ≤ 50 l/min and equipped with the following:

- a) **pressure gauge**;
- b) **temperature gauge**, for measuring temperatures between 0 °C to 40 °C.

5.1.2.11 Barometer, required for measuring the ambient air pressure.

5.1.2.12 High-pressure vessel (see detail in Figure 4 for the construction), of which all parts consist of stainless steel.

The high-pressure sampling apparatus specified in ISO 6978-1 may also be used by adapting it for two sampling tubes. The high-pressure apparatus may also be used for sampling at atmospheric pressure.

5.1.2.13 Connections, between the inlet of the vessel and the sampling tubes consisting of a ball socket with screw cap and dividable screw.

5.2 Desorption station (see Figure 5), comprising the following:

5.2.1 Tube oven, for the thermal desorption of mercury from the quartz glass sampling tubes or quartz glass analytical tubes.

The length of the heating zone of the oven should be (120 ± 20) mm to cover the part of the tubes filled with Au/Pt-alloy thread. The inner diameter shall allow the free passage of the tube sockets. The heating capacity of the oven shall be capable of reaching 800 °C within ≤ 2 min.

5.2.2 Quartz glass analytical tubes (see Figure 3).

5.2.3 Mercury trap (see Figure 5), filled with sulfur impregnated activated charcoal or any other suitable mercury adsorbent such as gold/platinum alloy.

5.2.4 Air pump, capable of delivering a flow rate between 0,5 l/min and 2 l/min.

5.2.5 Flow meter, for measuring flow rates ranging between 1 l/min and 5 l/min.

5.2.6 Polyvinyl acetate (PVA) tubing, having an internal diameter of 3 mm.

5.3 Cold vapour atomic absorption spectrometer (AAS) or atomic fluorescence spectrometer (AFS).

A cold vapour AAS or an AFS with an integrator and a mercury unit, capable of detecting at least 0,05 ng Hg, standard laboratory equipment and polyvinyl acetate (PVA) tubing are required. However, hoses of other suitable plastic material, such as polytetrafluoroethylene (PTFE) or polyamide (PA), may be used.

It is essential to make sure that the flowrate transporting the mercury through the analytical system remains constant.

5.4 Calibration set (see Figure 6), for the preparation of mercury-saturated air (6.6), consisting of the elements given in 5.4.1 to 5.4.7.

5.4.1 Bottles, of 500 ml capacity.

5.4.2 Screw caps with polytetrafluoroethylene (PTFE)-coated silicone rubber septa.

5.4.3 PVA tubing.

5.4.4 Stainless steel syringe needles.

5.4.5 Thermometer, with a range from 10 °C to 40 °C and graduated to 0,1 °C.

5.4.6 Insulated box.

5.4.7 Gastight glass syringe, equipped with a **PTFE plunger**, with a **stainless steel needle**, capable of delivering a volume of 0,5 ml to 5 ml.

5.5 Sampling and analytical tubes (see Figure 3).

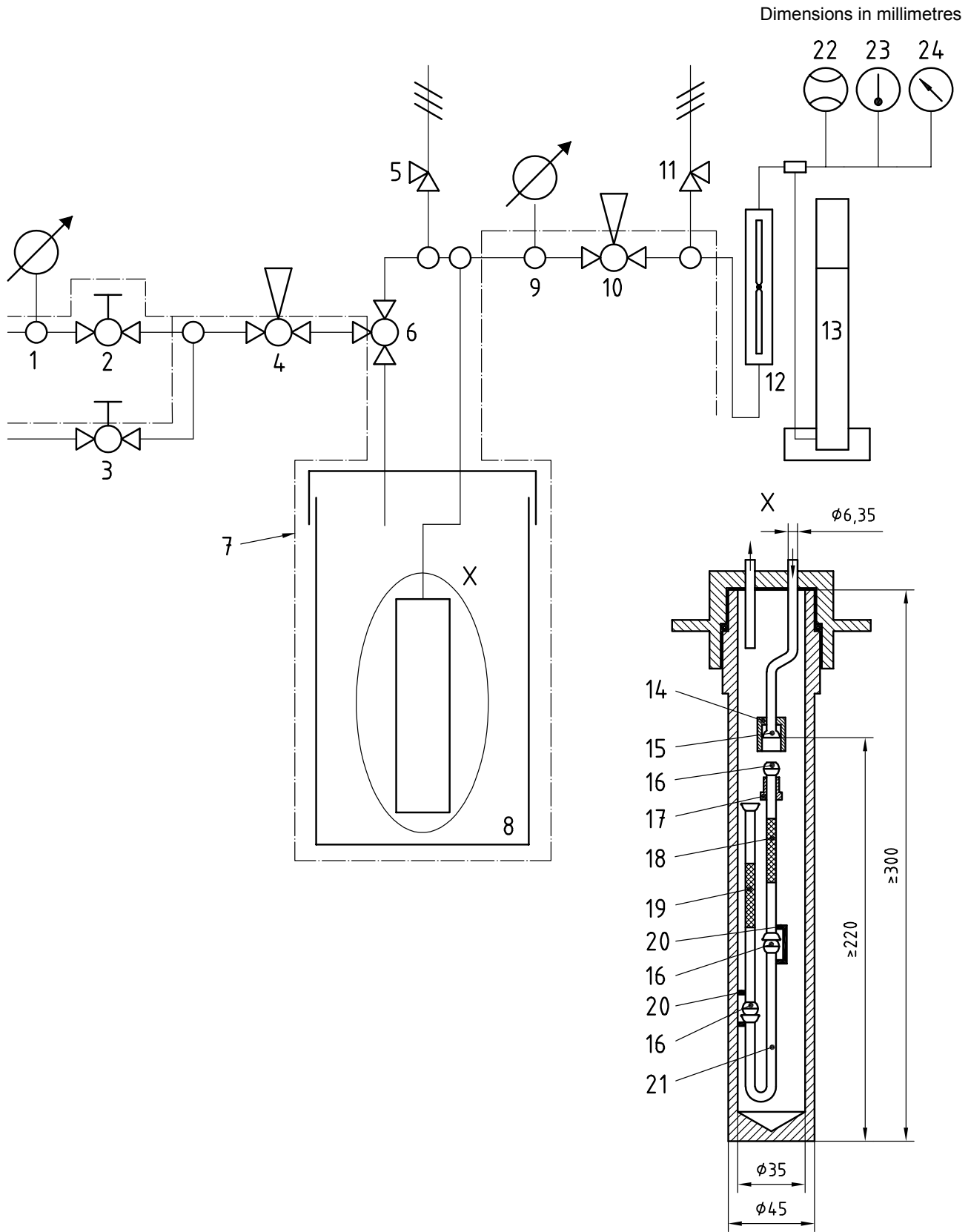

Key

- | | |
|---------------------------------------|--|
| 1 pressure gauge (0 MPa to 25 MPa) | 13 water lock set at 0,4 m water column |
| 2 valve | 14 screw cap M20 |
| 3 bypass valve | 15 ball socket |
| 4 pressure-reducing valve | 16 O-ring |
| 5 pressure relief valve set at 10 MPa | 17 dividable screw M20 (polytetrafluoroethylene) |
| 6 three-way valve | 18 first sampling tube |
| 7 heating tape | 19 second sampling tube |
| 8 high-pressure vessel | 20 clamp |
| 9 pressure gauge (0 MPa to 10 MPa) | 21 connecting piece |
| 10 pressure-reducing valve | 22 gaz meter |
| 11 pressure relief valve set at 4 kPa | 23 temperature gauge |
| 12 flow indicator | 24 pressure gauge |

Figure 4 — Sampling apparatus for sampling at high pressure

Dimensions in millimetres

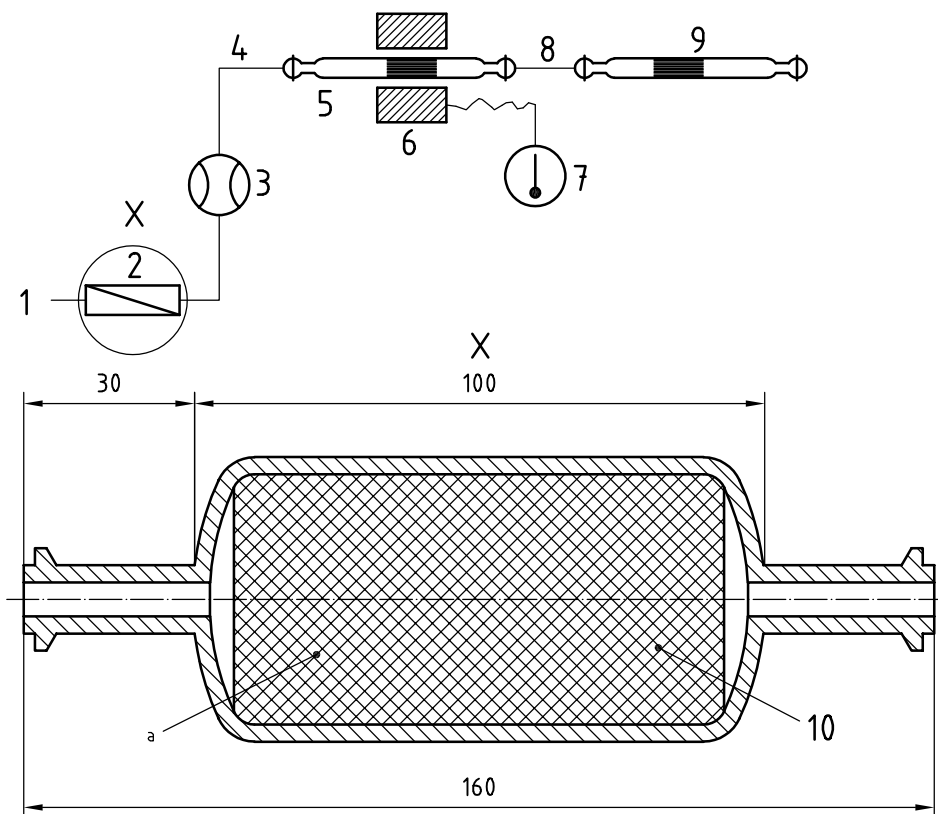

Key

- | | |
|-----------------|-------------------------|
| 1 air pump | 6 tube oven |
| 2 mercury trap | 7 temperature gauge |
| 3 flowmeter | 8 glass connection tube |
| 4 PVA tubing | 9 analytical tube |
| 5 sampling tube | 10 glass wool |
- a Mercury trap filled with activated charcoal impregnated with sulfur or any other suitable mercury adsorbent.

Figure 5 — Desorption station

6 Reagents and materials

Use only reagents and materials which contain negligible amounts of mercury.

6.1 Gold/platinum alloy thread, produced from gold/platinum alloy 80 % to 90 % gold (Au) and the remainder platinum (Pt) of 0,1 mm diameter and a length of 10 m (to fill one quartz glass tube).

Alternatively to gold/platinum alloy thread, silica spherules having a specific surface of about 10 m²/g and impregnated with 3 % Au by mass may be used.

6.2 Metallic mercury, of purity $\geq 99,9$ %.

DANGER — Mercury presents a health hazard if incorrectly handled. Avoid inhalation of the vapour. Spillages of mercury should be removed immediately, including places which are difficult to access. Use a plastic syringe to draw it up. Smaller quantities can be covered by sulfur powder and removed.

6.3 Solvents methanol and iso-octane.

6.4 Activated charcoal, impregnated with sulfur for air purification or any other suitable mercury adsorbent such as gold/platinum alloy.

6.5 Sulfur powder, for covering small amounts of spilled mercury.

6.6 Mercury-saturated air (see Figure 6).

Close two bottles (5.4.1), each containing 20 g of metallic mercury (6.2), with screw caps (5.4.2). Using PVA tubing (5.4.3) attached at both ends to stainless steel syringe needles (5.4.4), connect the bottles together by inserting the needles through each of the septums (see Figure 6). Keep the first bottle at atmospheric pressure by inserting another stainless steel syringe needle (5.4.4) through its septum. Equip the second bottle with a thermometer (5.4.5), not shown in Figure 6. Place the bottles in an insulated box (5.4.6) to minimize temperature fluctuations. Using a gastight glass syringe (5.4.7), withdraw mercury-saturated air from the second bottle by inserting the needle through its septum. Allow at least 1 h after set-up for the mercury-saturated air to reach stable conditions.

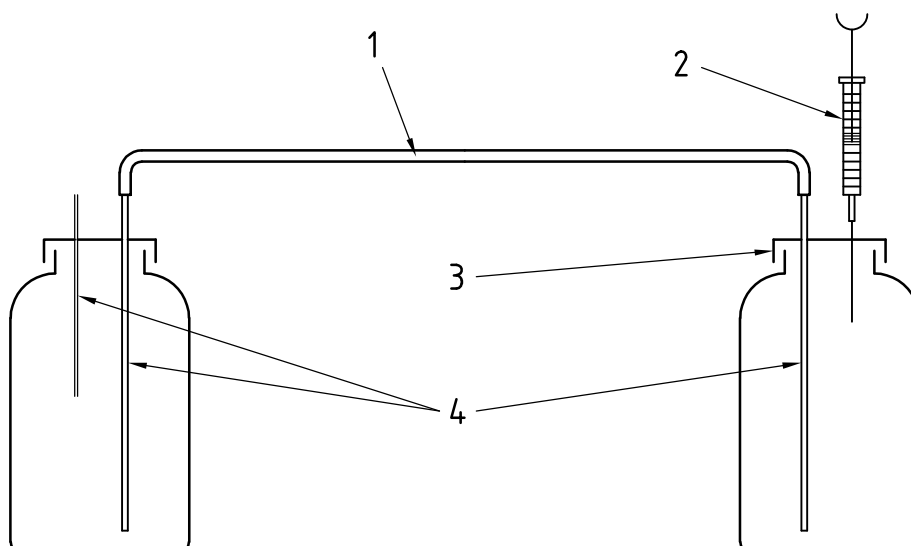

Key

- 1 PVA tubing
- 2 gastight glass syringe
- 3 screw cap with PTFE-coated silicone rubber septum
- 4 stainless steel syringe needles

Figure 6 — Calibration set to be placed in an insulated box

7 Preparation of sampling and analytical tubes

7.1 Filling

Crumple 10 m of gold/platinum alloy thread (6.1) into a ball, then pull it out to form a cylinder so as to fit into the sampling or analytical tubes (see Figure 3) and part of which sufficiently narrow to pass through the indentation. Introduce the crumpled thread cylinder into the tube so as to partially pass the indentation (15 ± 5) mm, then compress the thread to pack the filling of cross-section as shown in Figure 3. This should result in a filled zone of about (80 ± 5) mm for sampling tubes and about (60 ± 5) mm for analytical tubes.

For gold-impregnated silica, fill the tubes between plugs of glass wool to give a length of the sorption zone of (10 ± 1) mm.

7.2 Cleaning

Before use, thoroughly clean quartz glass tubes used for sampling and analysis by repeated heating to 800 °C for several minutes whilst purified air is passed through the tubes.

To check the mercury contamination of the tubes, connect them to the AAS or AFS as described in 7.3. If the tube contains $\geq 0,1$ ng Hg, repeat the cleaning procedure until this level is obtained.

After cleaning and allowing the tubes to cool, seal the tubes immediately with plastic film or clean rubber plugs and store them in a hermetically closed vessel. It is recommended to use at least one tube as a blank to check for possible contamination during storage.

7.3 Efficiency testing

Since the efficiency of sampling and analytical tubes can decline with time and/or usage, mercury can pass through the tube without being sorbed. The efficiency should be checked periodically depending on use, especially when the Hg concentration is lower than with parallel measurements with other tubes or when the ratio of Hg found in the first and second tube differs to parallel measurements.

Check the efficiency by connecting a tube to the AAS or AFS and sucking air or inert gas through the tube into the measuring cell of the AAS or AFS. Then inject a small volume of mercury-saturated air (see 6.6) containing about 10 ng Hg. If the AAS or AFS displays a response for mercury greater than 0,1 ng Hg, the efficiency is not acceptable and the gold/platinum alloy thread in the tube has to be reactivated by heating the tube several times for 10 min to 20 min to 800 °C whilst passing a gentle stream of purified air through the tube.

After this procedure, check the efficiency again. When the efficiency test is successful, clean the tube as specified in 7.2.

8 Sampling

SAFETY PRECAUTIONS — Sampling shall follow all relevant safety regulations in accordance with ISO 10715. All the equipment used should comply with the specific local safety regulations.

8.1 General

In natural gas, mercury is found at extremely low concentration levels. Consequently, to determine mercury at such low levels, it is necessary to take certain precautions in order to obtain reliable results. Such trace analysis is strongly affected by the following:

- a) the sorption of mercury by the sampling equipment, resulting in false, lower levels of mercury;

b) contamination of equipment or the laboratory air with mercury, resulting in false, higher levels of mercury.

Therefore, it is necessary to check all the equipment and chemicals used in the method prior to use.

Mercury is easily sorbed by most materials commonly available for sampling. Therefore, to obtain acceptable results, use quartz glass, borosilicate glass and stainless steel. Depending on the length of the lines, the material used and the flowrate, preconditioning of the sampling system is recommended. For the transfer of mercury vapour to the spectrometer, polyvinyl acetate (PVA) tubing connections are recommended. However, other suitable plastics, for instance polytetrafluoroethylene (PTFE) or polyamide (PA), may be used.

The uncertainty of the volume measurement (volume, temperature and pressure of the gas as well as ambient air pressure) directly contributes to the uncertainty of the content of mercury determined in the gas. Therefore, suitable measuring equipment, calibrated against a commonly accepted reference, shall be used to minimize the uncertainty of the volume measurement to less than 1 %.

8.2 Conditions for representative sampling

For general aspects of natural gas sampling, see ISO 10715. Direct sampling is performed discontinuously, due to the sorption phenomena mentioned in 8.1 in accordance with ISO 10715 preferably at operating pressure.

Purge the sampling system (sample probe and sampling valve) prior to sampling so as to remove any deposits or impurities. Avoid any excessive purging because it may possibly cause the sampling valve to freeze as a result of gas expansion (Joule-Thomson effect).

The sampling and transfer lines should be as short as possible.

It is strongly recommended to use a fast loop to bypass the sorption tubes. This guarantees high gas velocity in the sampling system (sample probe and sampling valve) and minimizes any sorption phenomena. This is particularly important when the pressure is reduced for sampling and when the sampling method only requires a relatively small gas volume.

8.3 Sampling procedure at atmospheric pressure (see Figure 1)

Carry out the sampling at atmospheric pressure. Sampling at low pressure (near atmospheric pressure) is directly performed on low-pressure systems (5.1.1). When sampling has to be performed from a high-pressure source, heat the gas prior to pressure reduction. Also heat the pressure control valve to avoid any condensation and sorption phenomena.

When using low flow rates of about 2 l/min, first flush the sampling system (sample probe, sampling valve and pressure regulator) sufficiently. As a general rule, flush at least 10 times the dead volume of the sampling system multiplied by the gas pressure. To minimize sorption due to low gas velocities in the high pressure branch of the sampling system, use a bypass line with a flow rate at least 10 times higher than the sample flow rate.

Connect the sampling apparatus (see Figure 1) to the sampling valve. When the pressure has to be reduced before sampling, heat the gas stream in a heat exchanger to a temperature so that the gas temperature after expansion is more than 10 °C higher than the dewpoint. (The temperature of natural gas will drop by 4 K/MPa.)

Heat the aluminium block (5.1.1.4 and Figure 1) to the same temperature. Adjust the first bypass flowrate to about 20 l/min. Adjust the gas flow through the sampling tubes via the three-way valve (5.1.1.3 and Figure 1) and through the second bypass to a flowrate of about 2 l/min. Flush through for at least 1 h before starting sampling while the sampling tubes are bypassed or replaced by spare tubes.

To avoid overloading of the AAS or AFS with mercury (decontamination can take many hours), the amount of mercury collected should be within the measuring range of the AAS or AFS. Therefore it is recommended to start with a low sample volume, i.e. 5 l for the first attempt, increasing the volume to an appropriate mercury

indication of the AAS or AFS. Take several samples using different sample volumes, if measurements are to be made in a laboratory remote from the sampling station.

After these preparatory steps with the three-way valve (5.1.1.3) still in the bypass position, connect two clean sampling tubes glass to glass by a short elastic silicone tube and place them into the aluminium block heated to more than 10 °C higher than the dewpoint. Connect the sampling tubes on one side with the three-way valve and on the other side with the flow and gas meter. Read the initial value of the gas meter (V_i) and turn the three-way valve to pass the gas sample. Note the gauge pressure (p_G) and the gas temperature (t_G) during sampling at regular intervals and, at minimum, take readings at the beginning and the end of sampling.

When the predetermined volume of gas has passed through the sampling tubes, switch the three-way valve to bypass the sampling tubes. Read the final value of the gas meter (V_f), disconnect the sampling tubes from the sampling apparatus, remove them from the aluminium block and close the ends as mentioned in 7.2. Note also the time and the date of sampling and the ambient air pressure (p_a). Note which sampling tube was the first and which was the second. Also mark the flow direction.

If upon visual inspection, the sampling tubes contain liquid condensates after sampling, discard the sample (unreliable results) and change the sampling conditions, e.g. temperature of the gas and sample volume. Clean the sampling tubes as specified in 8.5.

During the sampling process (possibly due to the effect of condensate covering the surface of the gold/platinum alloy thread), mercury can pass through the first tube. If more than 25 % of the total mercury content of both tubes passes through the first tube, reduce the flowrate during sampling and/or the sample volume. If less than 10 % has passed, then increase the flow rate and/or the sample volume.

If condensate is suspected to be collected in the tubes, thereby reducing their sampling efficiency, check the efficiency as specified in 7.3 by injecting a small volume of mercury-saturated air (6.6) containing about 5 ng Hg into a loaded sampling tube. A breakthrough of mercury indicates either an adverse effect of invisible condensate or overloading of the adsorbent. In this case, clean the sampling tube as specified in 7.2.

Preferably analyse the samples on-site but they may also be sealed with a plastic film or with clean rubber plugs and stored in a hermetically closed vessel for up to one week before analysis. It is recommended to store at least one blank sampling tube with the samples to control mercury contamination during storage.

8.4 Sampling procedure at high pressure (see Figure 4)

High-pressure sampling (above atmospheric pressure) allows a rather large volume of gas to be passed through the sampling tube(s) in a short time without changing the pressure and temperature of the gas. This may also prevent retrograde condensation of hydrocarbons. Heat exchangers are required to heat the gas prior to pressure reduction so that the gas sample volume can be measured accurately; the bypass should be reintroduced either to a low-pressure pipeline or to a flared and/or vented outlet for safety reasons.

Briefly open the sampling valve connected to the pipeline (not shown in Figure 4) to blow out any deposits or impurities. Take care to prevent excessive blowing out, as otherwise the Joule-Thomson effect will cause the valve to ice up. Keep the feedline (stainless steel) from the sampling valve to the sampling unit (shown in Figure 4) as short as possible to prevent losses by adsorption on the inside surface of the feedline as well as avoiding a temperature drop.

Heat the sampling equipment and lines to a temperature about 10 °C above the dewpoint. Refer to Figure 4 for the following procedure. Connect the first sampling tube (filled according to 7.1 with gold/platinum alloy thread) to the inlet ball socket of the high-pressure vessel by means of the screw cap and the dividable screw using an O-ring. Connect the second sampling tube to the first one using a glass connecting piece and clamps. Close the high-pressure vessel and connect it to the sampling equipment. With the valve (2 in Figure 4) closed, open the sampling valve (not shown in Figure 4) and read the pressure on the pressure gauge (0 MPa to 25 MPa). With the pressure-reducing valve (4 in Figure 4) upstream to the high-pressure vessel closed, open the valve (2 in Figure 4) and then open the bypass valve (3 in Figure 4) to flush the sampling lines. Place the three-way valve (6 in Figure 4) in a position to bypass the high-pressure vessel. With the pressure-reducing valve (10 in Figure 4) downstream to the high-pressure vessel closed, open the pressure-reducing valve (4 in Figure 4) upstream to the high-pressure vessel slowly. Then open the pressure-reducing valve (10 in Figure 4)

downstream to the high-pressure vessel slowly and adjust the flowrate to the gas meter to approximately 20 l/min by means of the flow indicator (12 in Figure 4).

After flushing the equipment thoroughly for at least 1 h, turn the three-way valve (6 in Figure 4) to a position so that the gas flows through the high-pressure vessel. At the same time, take the gas meter reading (V_i). During sampling, take readings at the gas meter of the gas temperature t_G and gauge pressure p_G at regular intervals, and, at minimum, take readings at the beginning and the end of the sampling. When sufficient gas has passed the sampling tubes, turn the three-way valve (6 in Figure 4) to a position to bypass the high-pressure vessel and simultaneously take the gas meter reading (V_f). Close the pressure-reducing valve (4 in Figure 4) upstream to the high-pressure vessel and remove the sampling tubes from the high-pressure vessel as soon as atmospheric pressure is reached. Seal both ends of the sampling tubes as mentioned in 7.2. Note also the time and date of sampling and ambient air pressure (p_a) as well as which sampling tube was first and which one was second. Also mark the flow direction on the tubes.

To avoid overloading of the AAS or AFS with mercury, make sure the collected amount of mercury remains within the measuring range of the AAS or AFS. Decontamination of some AAS detectors may take several hours. Therefore, it is recommended to start with a low sample volume, e.g. 20 l for the first attempt, then increasing the volume to an appropriate mercury indication of the AAS or AFS. Take several samples using different sample volumes if measurements are to be made in a laboratory remote from the sampling station.

If upon visual inspection the sampling tubes contain liquid condensates after sampling, discard the sample (unreliable results) and change the sampling conditions, e.g. temperature of the gas and sample volume. Clean the sampling tubes as specified in 8.5.

During the sampling process (possibly due to the effect of condensate covering the surface of the gold/platinum alloy thread), mercury can pass through the first tube. If more than 25 % of the total mercury content of both tubes passes through the first tube without being sorbed, reduce the flowrate during sampling and/or the sample volume. If less than 10 % of the total mercury passes through the first tube without being sorbed, then increase the flowrate and/or the sampling volume.

Preferably analyse the samples on-site but they may also be sealed with a plastic film or with clean rubber plugs and stored in a hermetically closed vessel for up to one week before analysis. It is recommended to store at least one blank sampling tube with the samples to control mercury contamination during storage.

8.5 Removal of condensate from discarded sampling tubes

To remove condensate (hydrocarbons and water), especially when sampling mercury from raw gas, wash the sampling tubes successively with 5 ml iso-octane and 5 ml of methanol. After shaking out remaining solvent, dry the tubes by passing a gentle stream of purified air (mercury trap filled with mercury adsorbent, see Figure 5) through the tubes. The tubes are dried after flushing for at least 3 min at ≥ 20 °C. Then clean them as specified in 7.2. It may also be advisable to check the sampling efficiency as specified in 7.3 before use.

9 Mercury determination

DANGER — Mercury presents a health hazard if incorrectly handled. Avoid inhalation of the vapour. Spillages of mercury should be removed immediately, including places which are difficult to access. Use a plastic syringe to draw it up. Smaller quantities can be covered by sulfur powder and removed.

9.1 Transfer of mercury to the analytical tube (double amalgamation)

Connect each sampling tube successively in the desorption station (see 5.2 and Figure 5) to an analytical tube. Ensure that the direction of the flow is opposite to that of the flow during sampling. Place the sampling tube into the cold tube oven (< 200 °C) (Figure 5) and connect it to PVA tubing via the mercury trap to an air pump. Adjust the flowrate of air to 500 ml/min using the flow indicator. Heat the tube oven to 700 °C as indicated by the temperature gauge. Wait for 1 min and then turn off the heating. Disconnect the sampling tube from the analytical tube and the air supply and remove them from the oven.

Desorb the mercury in sampling tubes within one week after sorption.

9.2 Transfer of mercury to AAS or AFS instrument

Connect the analytical tube to the inlet of the AAS or AFS (5.3) using PVA tubing and put it in the oven maintained at a temperature below 200 °C. Rapidly heat the tube oven to about 800 °C and use a suitable carrier gas to carry the mercury vapour to the detector. Note the response of the integrator.

9.3 Calibration

Calibrate the AAS or AFS by introducing known quantities of mercury (measured volume of mercury-saturated air) prior to calculating the mercury content of the tubes.

Allow the mercury-saturated air (6.6) in the calibration set (5.4) and the gas-tight syringe sufficient time (see Figure 6 and 6.6) for equilibrating at a constant temperature equal to, or lower than, ambient temperature. Fill the syringe with mercury-saturated air from the second bottle (see Figure 6) and store the syringe inside the insulated box for several minutes to allow preconditioning. Remove the syringe and empty it in the first bottle. Fill the syringe again over a period of 3 s to 4 s, sucking the vapour from the second bottle. Always over-fill the syringe, wait several seconds and expel the extra volume exceeding 0,5 ml back into the same bottle. Note the temperature inside the insulated box. Inject the mercury-saturated air immediately via a T-piece with septum mounted in the desorption station (5.2) upstream of a clean sampling tube. Sufficiently purge the desorption system with purified air (mercury trap) so as to transfer the injected mercury vapour quantitatively into the sampling tube.

Transfer the mercury as specified in 9.1 to the analytical tube and determine the mercury as specified in 9.2. Repeat injections and measurements until the relative standard deviation for at least three consecutive injections is less than 3 %. At least two calibrations at different levels within the measuring range are necessary for a first order calibration curve passing through the origin and at least three calibrations are necessary for curves not passing through the origin.

Derive the appropriate response factor for the measured integral of the sample from the calibration curve and the mercury content of saturated air at the appropriate temperature as listed in Table 1.

9.4 Blank test

Check the background level of mercury in ambient air by suction of air directly into the AAS or AFS. After reaching stable conditions, pass the air through the mercury trap before introducing it into the AAS or AFS. If the display value changes, the background level of Hg is too high and the instrument should be placed in another location. If this is not possible, take special precautions by using a mercury trap for the air flowing through the AAS or AFS.

10 Calculation

Calculate the mass, expressed in nanograms, of mercury, m_{Hg} , collected on both sampling tubes using Equation (1):

$$m_{\text{Hg}} = \frac{A}{R_f} \quad (1)$$

where

A is the integrated signal, expressed in arbitrary units, indicated by the AAS or AFS;

R_f is the response factor, expressed in arbitrary units per nanogram, derived from the calibration curve;

Calculate the gas volume sampled, expressed in litres, V_G , at 273,15 K and 1 013,25 hPa using Equation (2):

$$V_G = \frac{(V_f - V_i) \times (p_a + p_G) T_N}{p_N (T_N + t_G)} \quad (2)$$

where

V_f is the final volume reading, expressed in litres, of the gas meter;

V_i is the initial volume reading, expressed in litres, of the gas meter;

p_a is the ambient air pressure, expressed in hectopascals;

p_G is the gauge pressure, expressed in hectopascals, of the gas meter (averaged for duration of sampling);

t_G is the gas temperature, expressed in degrees Celsius, inside the gas meter (averaged for duration of sampling);

T_N is the normal temperature equal to 273,15 K;

p_N is the normal pressure equal to 1 013,25 hPa.

Calculate the mercury content as mass concentration, β_{Hg} , expressed in nanograms per litre (ng/l), and equal to micrograms per cubic metre ($\mu\text{g}/\text{m}^3$) at normal conditions according to Equation (3):

$$\beta_{Hg} = \frac{m_{Hg}}{V_G} \quad (3)$$

Table 1 — Saturated concentration of mercury in air at different temperatures

Temperature °C	Concentration ng/ml	Temperature °C	Concentration ng/ml	Temperature °C	Concentration ng/ml	Temperature °C	Concentration ng/ml	Temperature °C	Concentration ng/ml	Temperature °C	Concentration ng/ml	Temperature °C	Concentration ng/ml
10,0	5,55	15,0	8,62	20,0	13,18	25,0	19,85	30,0	29,50	35,0	43,27	40,0	62,68
10,1	5,60	15,1	8,69	20,1	13,29	25,1	20,01	30,1	29,73	35,1	43,60	40,1	63,14
10,2	5,65	15,2	8,77	20,2	13,40	25,2	20,18	30,2	29,97	35,2	43,93	40,2	63,60
10,3	5,70	15,3	8,84	20,3	13,51	25,3	20,34	30,3	30,20	35,3	44,26	40,3	64,07
10,4	5,75	15,4	8,92	20,4	13,62	25,4	20,50	30,4	30,44	35,4	44,60	40,4	64,54
10,5	5,81	15,5	9,00	20,5	13,74	25,5	20,67	30,5	30,67	35,5	44,93	40,5	65,01
10,6	5,86	15,6	9,08	20,6	13,85	25,6	20,83	30,6	30,91	35,6	45,27	40,6	65,48
10,7	5,91	15,7	9,15	20,7	13,97	25,7	21,00	30,7	31,15	35,7	45,61	40,7	65,96
10,8	5,96	15,8	9,23	20,8	14,08	25,8	21,17	30,8	31,40	35,8	45,95	40,8	66,44
10,9	6,02	15,9	9,31	20,9	14,20	25,9	21,34	30,9	31,64	35,9	46,30	40,9	66,92
11,0	6,07	16,0	9,39	21,0	14,32	26,0	21,51	31,0	31,89	36,0	46,65	41,0	67,41
11,1	6,12	16,1	9,47	21,1	14,44	26,1	21,69	31,1	32,13	36,1	47,00	41,1	67,90
11,2	6,18	16,2	9,56	21,2	14,56	26,2	21,86	31,2	32,38	36,2	47,35	41,2	68,39
11,3	6,23	16,3	9,64	21,3	14,68	26,3	22,04	31,3	32,63	36,3	47,71	41,3	68,89
11,4	6,29	16,4	9,72	21,4	14,80	26,4	22,21	31,4	32,89	36,4	48,06	41,4	69,39
11,5	6,35	16,5	9,80	21,5	14,92	26,5	22,39	31,5	33,14	36,5	48,42	41,5	69,89
11,6	6,40	16,6	9,89	21,6	15,05	26,6	22,57	31,6	33,40	36,6	48,79	41,6	70,39
11,7	6,46	16,7	9,97	21,7	15,17	26,7	22,75	31,7	33,66	36,7	49,15	41,7	70,90
11,8	6,52	16,8	10,06	21,8	15,30	26,8	22,93	31,8	33,92	36,8	49,52	41,8	71,42
11,9	6,57	16,9	10,14	21,9	15,42	26,9	23,11	31,9	34,18	36,9	49,89	41,9	71,93
12,0	6,63	17,0	10,23	22,0	15,55	27,0	23,30	32,0	34,44	37,0	50,26	42,0	72,45
12,1	6,69	17,1	10,32	22,1	15,68	27,1	23,49	32,1	34,71	37,1	50,64	42,1	72,98
12,2	6,75	17,2	10,41	22,2	15,81	27,2	23,67	32,2	34,97	37,2	51,01	42,2	73,50
12,3	6,81	17,3	10,50	22,3	15,94	27,3	23,86	32,3	35,24	37,3	51,39	42,3	74,03
12,4	6,87	17,4	10,59	22,4	16,07	27,4	24,05	32,4	35,52	37,4	51,78	42,4	74,57
12,5	6,93	17,5	10,68	22,5	16,20	27,5	24,24	32,5	35,79	37,5	52,16	42,5	75,10
12,6	6,39	17,6	10,77	22,6	16,34	27,6	24,44	32,6	36,06	37,6	52,55	42,6	75,64
12,7	7,05	17,7	10,86	22,7	16,47	27,7	24,63	32,7	36,34	37,7	52,94	42,7	76,19
12,8	7,12	17,8	10,95	22,8	16,61	27,8	24,83	32,8	36,62	37,8	53,33	42,8	76,73
12,9	7,18	17,9	11,04	22,9	16,74	27,9	25,02	32,9	36,90	37,9	53,73	42,9	77,29
13,0	7,24	18,0	11,14	23,0	16,88	28,0	25,22	33,0	37,18	38,0	54,13	43,0	77,84
13,1	7,31	18,1	11,23	23,1	17,02	28,1	25,42	33,1	37,47	38,1	54,53	43,1	78,40
13,2	7,37	18,2	11,33	23,2	17,16	28,2	25,62	33,2	37,76	38,2	54,93	43,2	78,96
13,3	7,43	18,3	11,42	23,3	17,30	28,3	25,82	33,3	38,04	38,3	55,34	43,3	79,53
13,4	7,50	18,4	11,52	23,4	17,44	28,4	26,03	33,4	38,33	38,4	55,75	43,4	80,10
13,5	7,57	18,5	11,62	23,5	17,58	28,5	26,23	33,5	38,63	38,5	56,16	43,5	80,67
13,6	7,63	18,6	11,72	23,6	17,73	28,6	26,44	33,6	38,92	38,6	56,57	43,6	81,25
13,7	7,70	18,7	11,82	23,7	17,87	28,7	26,65	33,7	39,22	38,7	56,99	43,7	81,83
13,8	7,77	18,8	11,92	23,8	18,02	28,8	26,86	33,8	39,52	38,8	57,41	43,8	82,41
13,9	7,83	18,9	12,02	23,9	18,16	28,9	27,07	33,9	39,82	38,9	57,84	43,9	83,00
14,0	7,90	19,0	12,12	24,0	18,31	29,0	27,29	34,0	40,12	39,0	58,26	44,0	83,59
14,1	7,97	19,1	12,22	24,1	18,46	29,1	27,50	34,1	40,43	39,1	58,69	44,1	84,19
14,2	8,04	19,2	12,32	24,2	18,61	29,2	27,72	34,2	40,74	39,2	59,12	44,2	84,79
14,3	8,11	19,3	12,43	24,3	18,76	29,3	27,93	34,3	41,05	39,3	59,56	44,3	85,39
14,4	8,18	19,4	12,53	24,4	18,91	29,4	28,15	34,4	41,36	39,4	59,99	44,4	86,00
14,5	8,25	19,5	12,64	24,5	19,07	29,5	28,37	34,5	41,67	39,5	60,44	44,5	86,61
14,6	8,33	19,6	12,74	24,6	19,22	29,6	28,60	34,6	41,99	39,6	60,88	44,6	87,22
14,7	8,40	19,7	12,85	24,7	19,38	29,7	28,82	34,7	42,31	39,7	61,33	44,7	87,84
14,8	8,47	19,8	12,96	24,8	19,54	29,8	29,05	34,8	42,63	39,8	61,77	44,8	88,47
14,9	8,54	19,9	13,07	24,9	19,69	29,9	29,27	34,9	42,95	39,9	62,23	44,9	89,09
15,0	8,62	20,0	13,18	25,0	19,85	30,0	29,50	35,0	43,27	40,0	62,68	45,0	89,72

11 Precision

Little statistical data is available for the repeatability, reproducibility and uncertainty of this method.

12 Test report

The test report shall include the following information:

- a) the date and time of sampling;
- b) the location where the sample was taken;
- c) a reference to this part of ISO 6978, i.e. ISO 6978-2;
- d) the conditions under which the gas was sampled such as temperature, pressure, flowrates;
- e) the analytical method (AAS or AFS instrument) used for the determination of mercury;
- f) total mercury content in $\mu\text{g}/\text{m}^3$ with calculated uncertainty; in accordance with the GUM;
- g) all calibration data;
- h) the corresponding blank measurements;
- i) any unusual features noted during sampling and determination.

Bibliography

- [1] ISO 641, *Laboratory glassware — Interchangeable spherical ground joints*
- [2] ISO 6570, *Natural gas — Determination of potential hydrocarbon liquid content — Gravimetric methods*
- [3] ISO 6978-1:2003, *Natural gas — Determination of mercury — Part 1: Sampling of mercury by chemisorption on iodine*
- [4] ISO 14111, *Natural gas — Guidelines to traceability in analysis*

