

INTERNATIONAL STANDARD

ISO 6972

Second edition
2002-09-15

Cranked-link mill chains of welded construction, attachments and sprockets

Chaînes en acier, de construction soudée, à maillons coudés, plaques-attaches et roues dentées



Reference number
ISO 6972:2002(E)

© ISO 2002

PDF disclaimer

This PDF file may contain embedded typefaces. In accordance with Adobe's licensing policy, this file may be printed or viewed but shall not be edited unless the typefaces which are embedded are licensed to and installed on the computer performing the editing. In downloading this file, parties accept therein the responsibility of not infringing Adobe's licensing policy. The ISO Central Secretariat accepts no liability in this area.

Adobe is a trademark of Adobe Systems Incorporated.

Details of the software products used to create this PDF file can be found in the General Info relative to the file; the PDF-creation parameters were optimized for printing. Every care has been taken to ensure that the file is suitable for use by ISO member bodies. In the unlikely event that a problem relating to it is found, please inform the Central Secretariat at the address given below.

© ISO 2002

All rights reserved. Unless otherwise specified, no part of this publication may be reproduced or utilized in any form or by any means, electronic or mechanical, including photocopying and microfilm, without permission in writing from either ISO at the address below or ISO's member body in the country of the requester.

ISO copyright office
Case postale 56 • CH-1211 Geneva 20
Tel. + 41 22 749 01 11
Fax + 41 22 749 09 47
E-mail copyright@iso.ch
Web www.iso.ch

Printed in Switzerland

Contents

Page

Foreword	iv
1 Scope	1
2 Normative reference	1
3 Chains	1
3.1 General	1
3.2 Nomenclature	1
3.3 Dimensions	2
3.4 Tensile strength	2
3.5 Length accuracy	2
3.6 Designation	2
3.7 Marking	2
4 Attachments	6
4.1 Types	6
4.2 Dimensions	6
5 Sprockets	13
5.1 Diametral dimensions	13
5.2 Tooth gap form	16
5.3 Rim profile	16
5.4 Tolerances	18
5.5 Marking	18

Foreword

ISO (the International Organization for Standardization) is a worldwide federation of national standards bodies (ISO member bodies). The work of preparing International Standards is normally carried out through ISO technical committees. Each member body interested in a subject for which a technical committee has been established has the right to be represented on that committee. International organizations, governmental and non-governmental, in liaison with ISO, also take part in the work. ISO collaborates closely with the International Electrotechnical Commission (IEC) on all matters of electrotechnical standardization.

International Standards are drafted in accordance with the rules given in the ISO/IEC Directives, Part 3.

The main task of technical committees is to prepare International Standards. Draft International Standards adopted by the technical committees are circulated to the member bodies for voting. Publication as an International Standard requires approval by at least 75 % of the member bodies casting a vote.

Attention is drawn to the possibility that some of the elements of this International Standard may be the subject of patent rights. ISO shall not be held responsible for identifying any or all such patent rights.

ISO 6972 was prepared by Technical Committee ISO/TC 100, *Chains and chain wheels for power transmission and conveyors*.

This second edition cancels and replaces the first edition (ISO 6972:1982), which has been technically revised. In particular, the references and terminology have been revised to bring them into conformity with other International Standards and current practice. Technical revisions comprise the addition of chain W855, in acknowledgement of the increased use of this type of chain, and the deletion of H1, H2, R1 and R2 attachments, which are no longer used. Furthermore, in clause 5, the pitch line clearance of sprockets has been altered for consistency with current industry practice.

Cranked-link mill chains of welded construction, attachments and sprockets

1 Scope

This International Standard specifies the characteristics of cranked-link¹⁾ mill chains of welded construction suitable for conveying bulk materials, together with associated attachments and chain sprockets. The chain dimensions specified in this International Standard ensure interchangeability of both complete chains and individual links for repair purposes.

This International Standard is applicable to sprockets with between 5 and 36 teeth.

Specifications are also given for eight types of attachment for use with the conveyor chains conforming to this International Standard.

2 Normative reference

The following normative document contains provisions which, through reference in this text, constitute provisions of this International Standard. For dated references, subsequent amendments to, or revisions of, any of these publications do not apply. However, parties to agreements based on this International Standard are encouraged to investigate the possibility of applying the most recent edition of the normative document indicated below. For undated references, the latest edition of the normative document referred to applies. Members of ISO and IEC maintain registers of currently valid International Standards.

ISO 286-2, *ISO system of limits and fits — Part 2: Tables of standard tolerance grades and limit deviations for holes and shafts*

3 Chains

3.1 General

The chain is designed to operate with the closed end of each link in the forward direction to produce the maximum scraping action against the material to be conveyed.

3.2 Nomenclature

The nomenclature of the chains and their component parts is specified in Figures 1 and 2.

1) In the USA, the term “offset sidebar” is used in place of “cranked link”.

3.3 Dimensions

Conveyor chain dimensions shall conform to those given in Table 1 (see Figure 3). Both maximum and minimum dimensions are specified to ensure interchangeability of links made by different chain manufacturers. Although these represent limits for interchangeability, they shall not necessarily be regarded as limits of tolerance for manufacture.

3.4 Tensile strength

3.4.1 Minimum tensile strength

The minimum tensile strength is that value which shall be exceeded when a tensile force is applied to a sample which is tested to destruction in accordance with 3.4.2.

NOTE This minimum tensile strength is not a working force. It is intended primarily as a comparative figure between chains of different construction. For application information, it is necessary to consult the manufacturers or their published data.

3.4.2 Tensile testing

A tensile force, not less than the minimum tensile strength specified in Table 1, shall be applied slowly to the ends of a chain, containing a minimum of three free pitches, by means of shackles so designed as to allow universal movement. The actual test method is at the discretion of the manufacturer.

Failure shall be considered to have occurred at the first point where increasing extension is no longer accompanied by increasing force, i.e. the summit of the force/extension diagram.

Any test in which failure occurs adjacent to the shackles shall be disregarded.

3.5 Length accuracy

Finished chains shall be measured either in the dry state or after light lubrication.

The standard nominal length for measurement shall be that nearest to 3 048 mm.

The chain shall be supported throughout its length and the measuring force specified in Table 1 shall be applied.

The finished chain length shall be equal to the nominal chain length $+ 0,32\%$.

Chains that work in parallel may be matched by agreement between the purchaser and the manufacturer.

3.6 Designation

The designation numbers for welded-steel-type cranked link mill chains are based on the ISO chain numbers given in Table 1. These numbers are derived from those given to the cast pintle or steel engineering type which they replace and have been given the prefix W to indicate that they are of welded design.

3.7 Marking

The chains shall be marked with the manufacturer's name or trademark and in addition should be marked with the appropriate ISO chain number given in Table 1.

The marking of the chain shall not be obscured by the attachments.

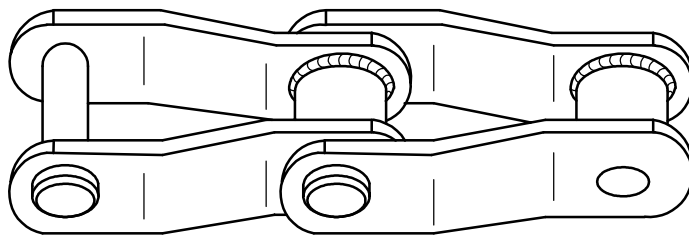

NOTE The illustration does not define the actual form of the cranked link.

Figure 1 — Cranked link chain assembly

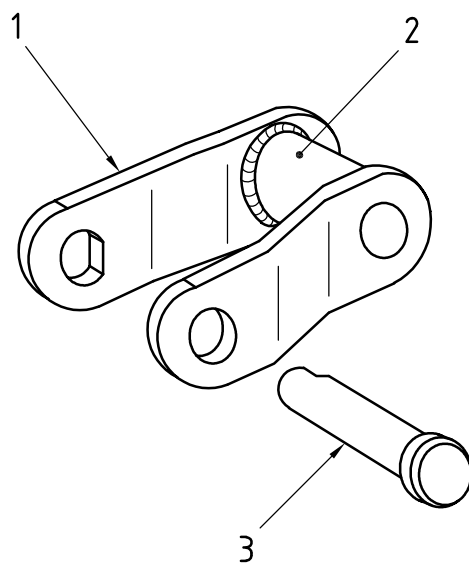

Key

- 1 Cranked plate
- 2 Bush
- 3 Connecting pin

NOTE The illustration does not define the actual form of the cranked link.

Figure 2 — Typical cranked link components

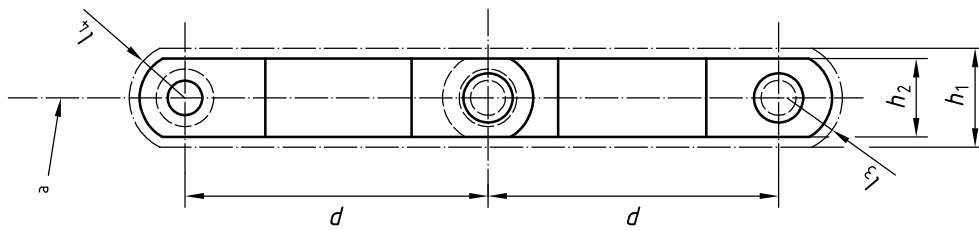

The overall width of connecting links is

$b_5 + b_6$, when riveted

$b_4 + b_5$, when there is a fastener at one side

$2 b_4$, when there is a fastener at both sides

The line of cranking, or offset, between l_1 and l_2 is straight.

NOTE The illustration does not define the actual form of the cranked link.

a Pitch line

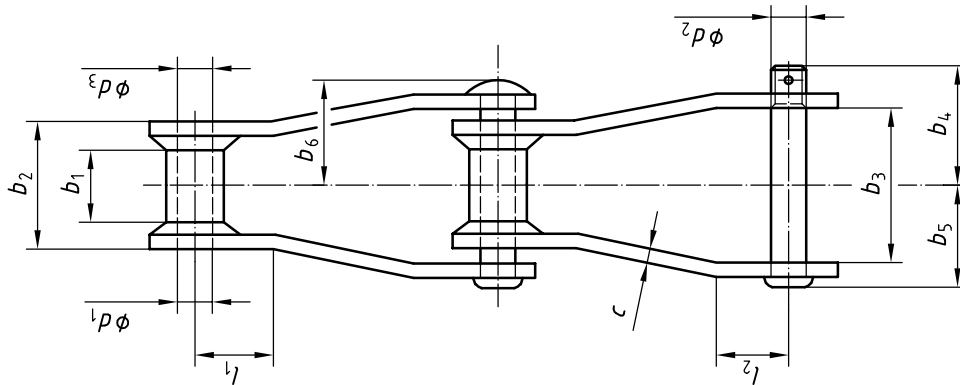

Figure 3 — Chain dimensions and symbols (see Table 1)

Table 1 — Chain dimensions, measuring forces and tensile strengths

ISO chain number	Pitch p^a	Bush diameter d_1 max.	Width between plates for sprocket contact at inner end b_1 min.	Connecting pin body diameter d_2 max.	Bush bore d_3 min.	Chain path depth h_1 max.	Plate depth h_2 max.	Crank clearance dimensions			Plate end clearance dimensions			Width over link at inner end b_2 max.	Width between plates at outer end b_3 min.	Width over pin fastening to centreline b_4 max.	Width over pin head to centreline b_5 max.	Width over rivet to centreline b_6 max.	Chain plate thickness c nom.	Measuring force	Tensile strength		
								l_1 min.	l_2 min.	l_3 max.	l_4 max.	l_3 max.	l_4 max.								Pin heat treated min.	All heat treated min.	
																						kN	
W78	66,27	22,9	28,4	12,78	12,9	30	28,4	16,5	17	16,8	16,8	16,8	51	51,6	45,2	39,6	42,7	6,4	0,9	93	107		
W82	78,1	31,5	31,8	14,35	14,48	33,5	31,8	19,8	21,1	19,6	20,8	20,8	57,4	57,9	48,3	41,7	45,2	6,4	1,33	100	131		
W106	152,4	37,1	41,2	19,13	19,25	39,6	38,1	22,9	27,2	26,4	26,9	26,9	71,6	72,1	62,2	56,4	59,4	9,6	1,78	169	224		
W110	152,4	32	46,7	19,13	19,25	39,6	38,1	22,9	27,2	26,4	26,9	26,9	76,5	77	62,2	54,9	59,4	9,6	1,33	169	224		
W111	120,9	37,1	57,2	19,13	19,25	39,6	38,1	22,9	27,2	22,6	26,9	26,9	85,6	86,4	69,8	63,5	64,3	9,6	1,78	169	224		
W124	101,6	37,1	41,2	19,13	19,25	39,6	38,1	22,9	27,2	22,6	26,9	26,9	71,6	72,1	62	56,4	59,4	9,6	1,78	169	224		
W124H	103,2	41,7	41,2	22,3	22,43	52,3	50,8	28,2	30,5	27,9	30,2	30,2	76,5	77	70,6	62,5	65,8	12,7	3,11	275	355		
W132	153,67	44,7	69,85	25,48	25,6	52,3	50,8	30	30,5	30	30,2	30,2	111,8	112,3	88,1	79,2	83,3	12,7	3,11	275	378		
W855	153,67	44,7	69,85	28,57	28,78	65	63,5	37,1	38,1	36,5	37,8	37,8	118,64	118,87	94,5	84,8	88,9	15,87	4,44	—	552		

^a The pitch, p , is a theoretical reference dimension used in the calculation of chain lengths and sprocket dimensions, and is not intended for use in the inspection of individual links.

4 Attachments

4.1 Types

This International Standard specifies eight types of attachment designated A1, A2, A22, F2, F4, K1, K2 and W1 with the following characteristics:

- A1, A2 and A22 have a mounting plate, with mounting holes, attached parallel to the pitch line on one cranked plate, as shown in Figures 4, 5 and 6;
- F2 and F4 have an angle section, with mounting hole, attached to the edge of each cranked plate, as shown in Figures 7 and 8;
- K1 and K2 have mounting plates, with mounting holes, attached parallel to the pitch line on both cranked plates, as shown in Figures 9 and 10;
- W1 has an angle section attached to the outer face of each cranked plate, as shown in Figure 11.

4.2 Dimensions

The respective dimensions of the attachments shall be as specified in Tables 2 to 9.

NOTE The actual form of the attachments is at the discretion of the manufacturer.

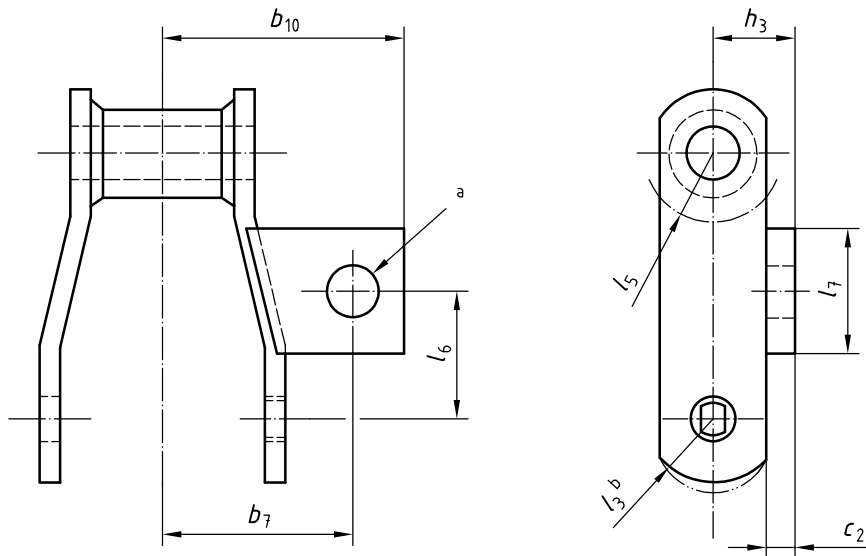

- a Hole for d_4 bolt.
- b For this dimension, see Table 1.

Figure 4 — A1 attachment

Table 2 — Dimensions of A1 attachment

Dimensions in millimetres

ISO chain number	b_7	l_6	l_7 max.	h_3 max.	b_{10} max.	c_2	l_5	Bolt diameter d_4^a
W78	50,8	31,8	36,6	22,4	65	6,4	16,8	9,7
W82	53,3	38,1	46	23,9	71,4	6,4	20,3	9,7

^a The actual hole diameter shall be large enough to provide adequate clearance for the specified bolt diameter.

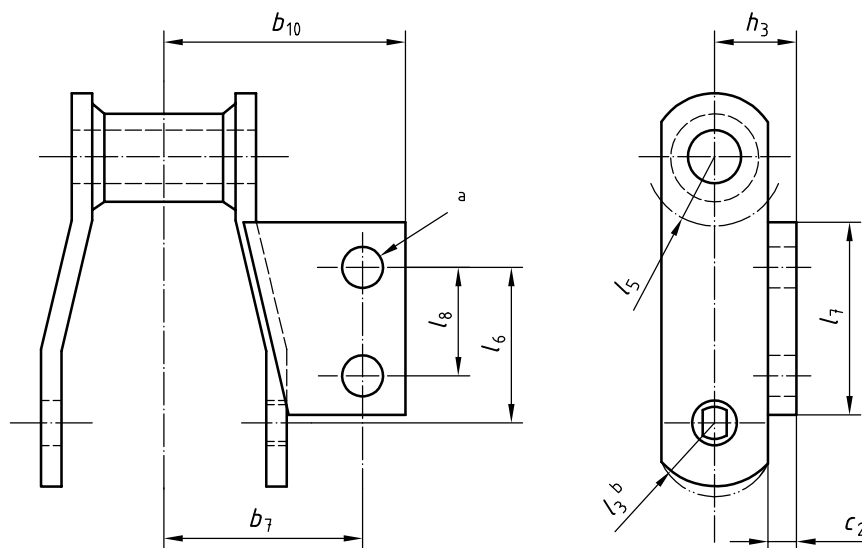

^a Hole for d_4 bolt.

^b For this dimension, see Table 1.

Figure 5 — A2 attachment

Table 3 — Dimensions of A2 attachment

Dimensions in millimetres

ISO chain number	b_7	l_6	l_7 max.	l_8	h_3 max.	b_{10} max.	c_2	l_5	Bolt diameter d_4^a
W78	50,8	38,9	52,3	28,4	22,4	65	6,4	16,8	9,7
W82	54,1	52,3	62	33,3	23,9	71,4	6,4	20,3	9,7
W110	67,6	98,6	84,1	44,4	30	84,1	9,7	23,1	9,7
W111	79,5	89,9	90,4	58,7	30	96,8	9,7	23,1	12,7
W124	66,8	71,4	77,7	49,3	30	90,4	9,7	23,1	9,7
W124H	66,8	73,2	80,8	49,3	39,6	82,8	12,7	28,4	12,7
W132	95,2	111,3	106,2	69,8	39,6	117,3	12,7	30,2	12,7

^a The actual hole diameter shall be large enough to provide adequate clearance for the specified bolt diameter.

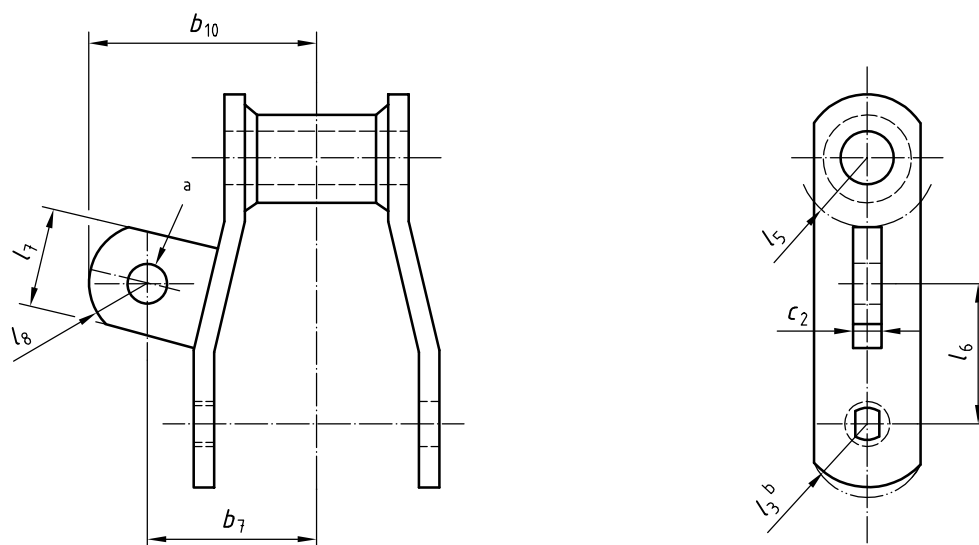

- a Hole for d_4 bolt.
- b For this dimension, see Table 1.

Figure 6 — A22 attachment

Table 4 — Dimensions of A22 attachment

Dimensions in millimetres

ISO chain number	b_7	l_6	l_7 max.	l_8 max.	b_{10} max.	c_2	l_5	Bolt diameter d_4^a
W78	47,8	33,3	30	18,3	65	9,7	16,8	9,7

^a The actual hole diameter shall be large enough to provide adequate clearance for the specified bolt diameter.

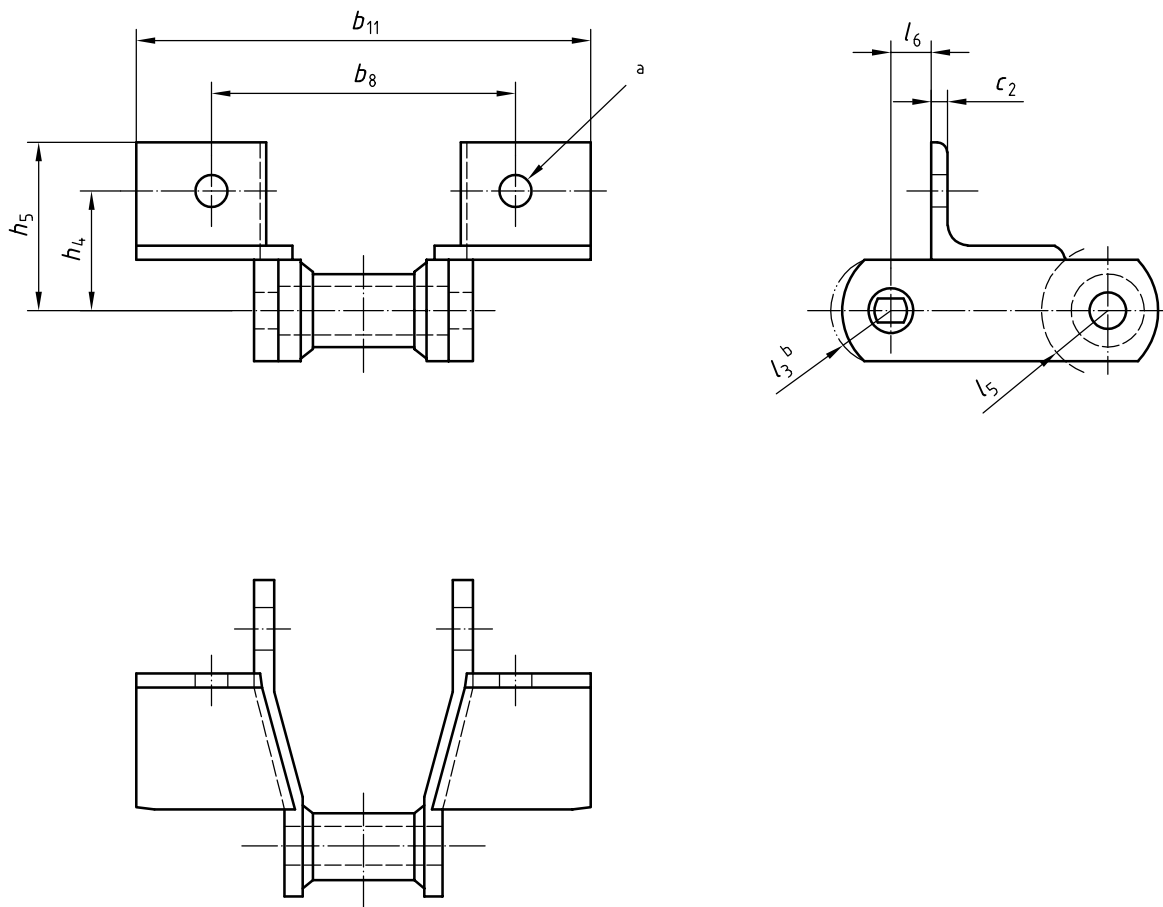

- a Holes for d_4 bolts.
- b For this dimension, see Table 1.

Figure 7 — F2 attachment

Table 5 — Dimensions of F2 attachment

Dimensions in millimetres

ISO chain number	b_8	l_6	h_4	h_5 max.	b_{11} max.	c_2	l_5	Bolt diameter d_4^a
W78	95,6	15,7	36,6	60,5	138,2	6,4	16,8	9,7

^a The actual hole diameter shall be large enough to provide adequate clearance for the specified bolt diameter.

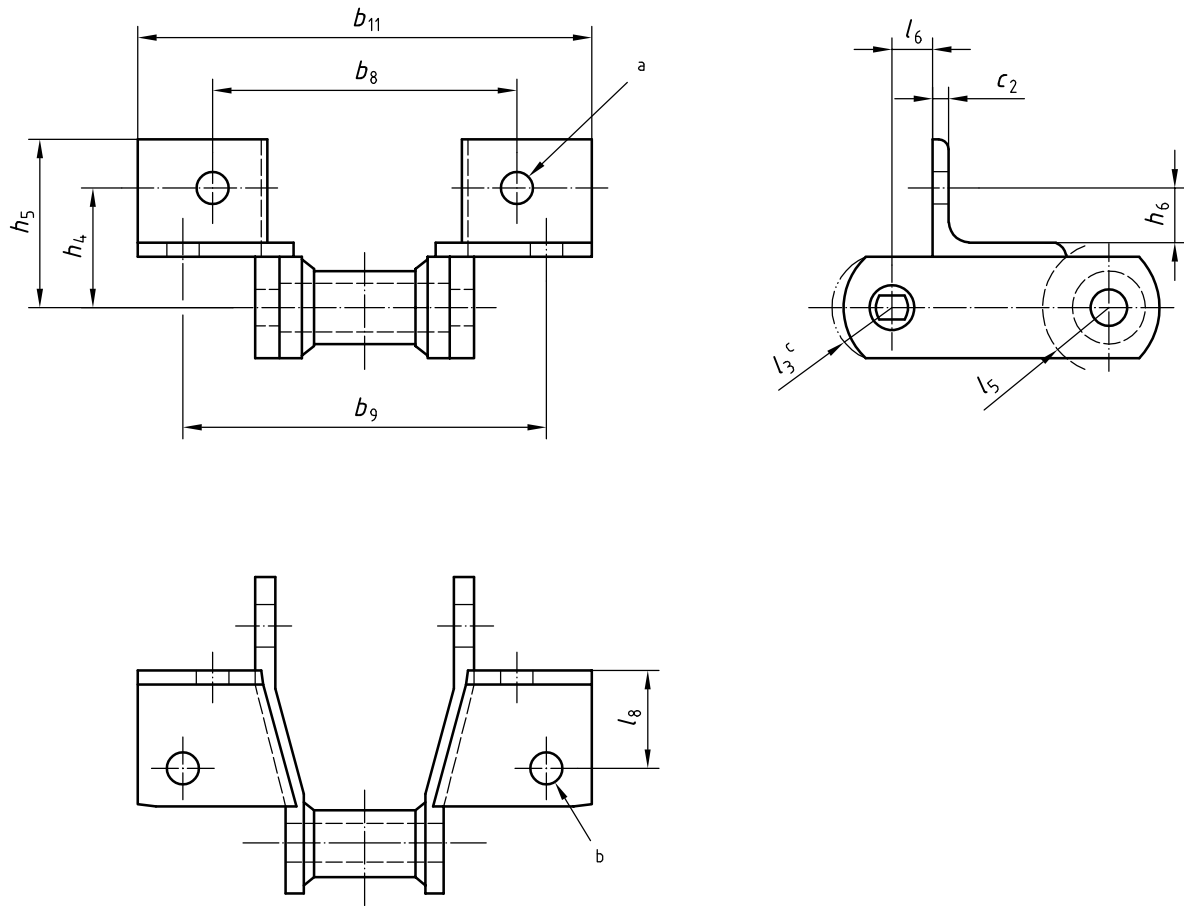

- a Two holes for d_4 bolts.
- b Two holes for d_5 bolts.
- c For this dimension, see Table 1.

Figure 8 — F4 attachment

Table 6 — Dimensions of F4 attachment

Dimensions in millimetres

ISO chain number	b_8	b_9	l_6	l_8	h_4	h_5 max.	h_6	b_{11} max.	c_2	l_5	Bolt diameter d_4^a	Bolt diameter d_5^a
W78	95,2	114,3	17,3	31,8	44,4	60,5	23,8	141,2	6,4	16,8	9,7	9,7
W82	104,6	127	20,6	28,4	46,2	62,5	23,8	150,9	6,4	20,3	9,7	9,7
W124	111,3	133,6	22,4	36,6	52,3	73,2	23,6	157	9,7	23,1	9,7	9,7

^a The actual hole diameter shall be large enough to provide adequate clearance for the specified bolt diameter.

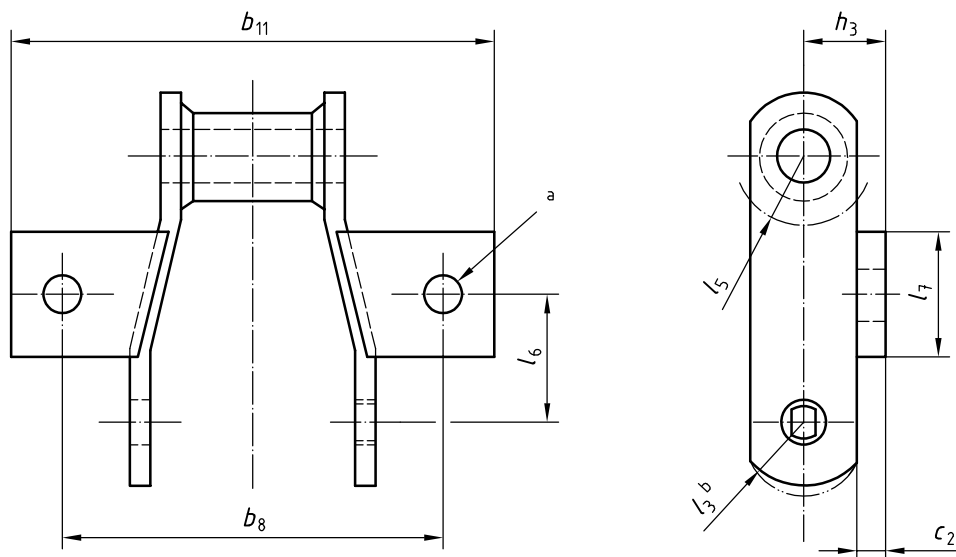

- a Holes for d_4 bolts.
- b For this dimension, see Table 1.

Figure 9 — K1 attachment

Table 7 — Dimensions of K1 attachment

Dimensions in millimetres

ISO chain number	b_8	l_6	l_7 max.	h_3 max.	b_{11} max.	c_2	l_5	Bolt diameter d_4^a
W78	101,6	31,8	36,6	22,4	130	6,4	16,8	9,7
W82	106,7	38,1	46	23,9	142,7	6,4	20,3	9,7

^a The actual hole diameter shall be large enough to provide adequate clearance for the specified bolt diameter.

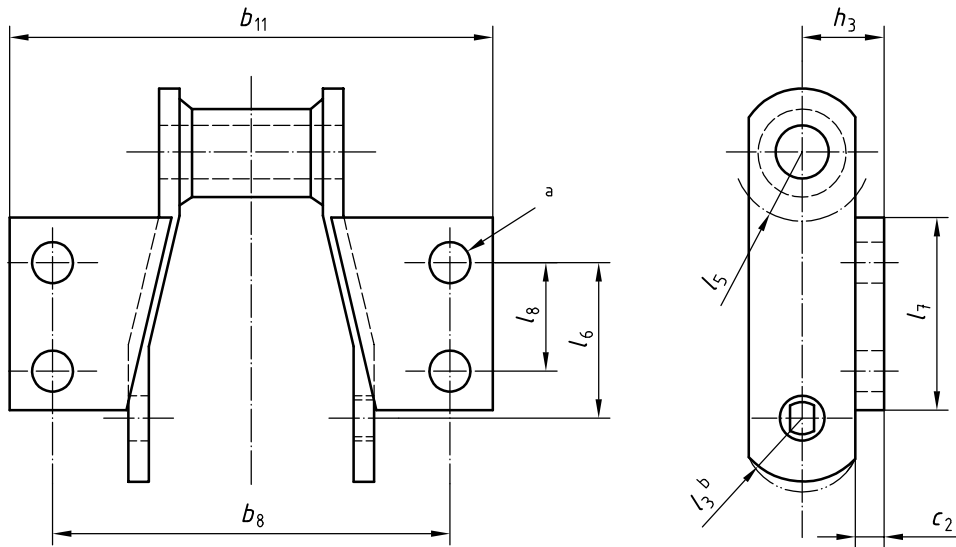

- a Holes for d_4 bolts.
- b For this dimension, see Table 1.

Figure 10 — K2 attachment

Table 8 — Dimensions of K2 attachment

Dimensions in millimetres

ISO chain number	b_8	l_6	l_7 max.	l_8	h_3 max.	b_{11} max.	c_2	l_5	Bolt diameter d_4^a
W78	101,6	38,9	52,3	28,4	22,4	130	6,4	16,8	9,7
W82	108,2	52,3	62	33,3	23,9	142,7	6,4	20,3	9,7
W110	135,1	98,6	84,1	44,4	30	168,1	9,7	23,1	9,7
W111	159	89,9	90,4	58,7	30	193,5	9,7	23,1	12,7
W124	133,6	71,4	77,7	49,3	30	180,8	9,7	23,1	9,7
W124H	133,6	73,2	80,8	49,3	39,6	165,6	12,7	28,4	12,7
W132	190,5	111,3	106,2	69,8	39,6	234,7	12,7	30,2	12,7

^a The actual hole diameter shall be large enough to provide adequate clearance for the specified bolt diameter.

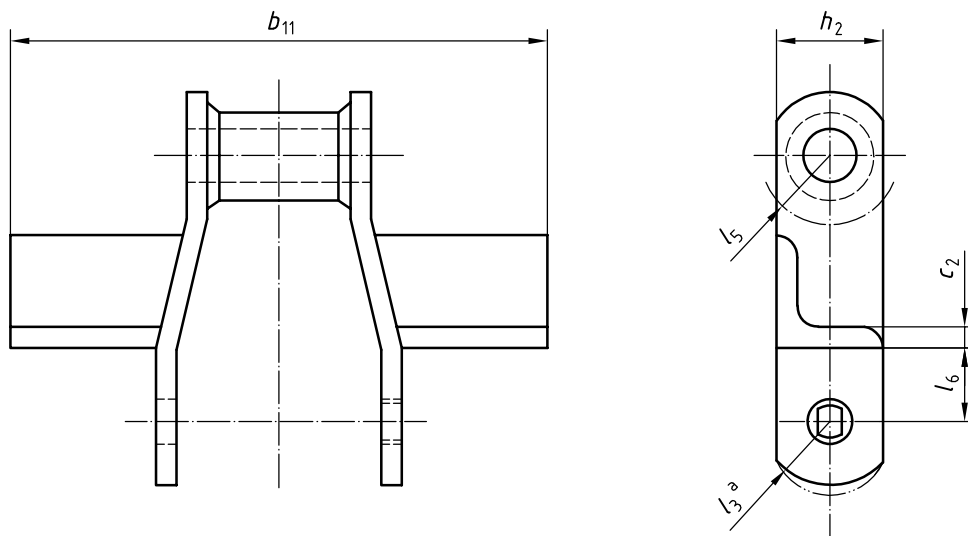

^a For this dimension, see Table 1.

Figure 11 — W1 attachment

Table 9 — Dimensions of W1 attachment

Dimensions in millimetres

ISO chain number	l_6	h_2 max.	b_{11} max.	c_2	l_5
W78	19,1	26,9	153,9	6,4	16,8
W82	23,9	33,3	166,6	6,4	20,3
W124	30	39,6	217,4	6,4	23,1
W124H	35,1	52,3	217,4	9,7	28,4
W132	38,1	52,3	316	9,7	30,2

5 Sprockets

5.1 Diametral dimensions

5.1.1 General

The sprocket diametral dimensions are shown in Figure 12 and specified in 5.1.2 to 5.1.6.

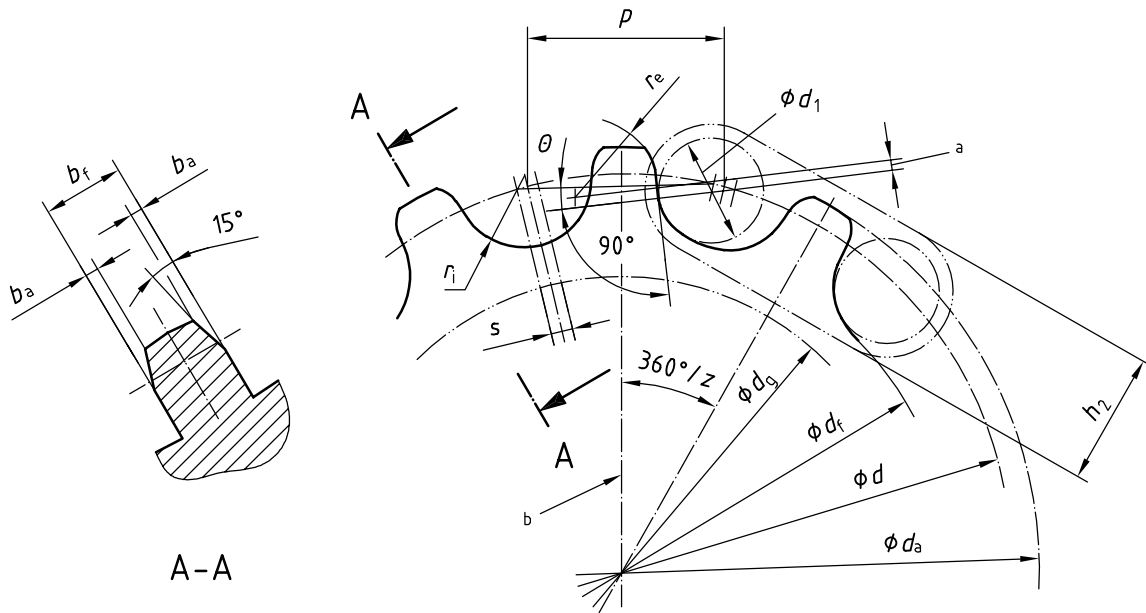

Key

- | | |
|--|---|
| b_a tooth side relief | h_2 plate depth (maximum) |
| b_f tooth width | p chordal pitch, equal to chain pitch |
| d pitch circle diameter | r_e tooth flank (topping radius) |
| d_a tip diameter | r_i bush seating radius |
| d_t root diameter | s pitch line clearance |
| d_g maximum chain clearance diameter | z number of teeth |
| d_1 bush diameter (maximum) | θ pressure angle |
| a Working face | |
| b Centreline of tooth | |

Figure 12 — Diametral dimensions and tooth form

5.1.2 Pitch circle diameter, d

$$d = p \times p_{cf}$$

where p_{cf} is the pitch diameter factor according to the number of teeth, as specified in 5.2.4 and Table 10.

5.1.3 Tip diameter, d_a

$$d_a = (p \times d_{gf}) + h_2$$

where d_{gf} is the chain clearance diameter and outside diameter factor according to the number of teeth, as specified in 5.2.5 and Table 10.

The tip diameter may be increased to give a full height tooth when the top of the chain is clear of scrapers flights, pans, buckets, etc.

5.1.4 Measuring pin diameter, d_R

$$d_R = d_1$$

where d_1 is the bush diameter, as specified in Table 1.

5.1.5 Root diameter, d_f

$$d_f \text{ max.} = (p \times p_{cf}) - d_1$$

NOTE Root diameters exceeding the maximum obtained from this equation result in improper chain and sprocket action and excessive chain loads.

5.1.6 Measurement over measuring pins, M_R

The measurement over measuring pins is illustrated in Figure 13.

$$M_R \text{ for even numbers of teeth} = d + d_R \text{ min.}$$

$$M_R \text{ for odd numbers of teeth} = d \cos \frac{90^\circ}{z} + d_R \text{ min.}$$

For a sprocket having an even number of teeth, measurement shall be made over the appropriate pins inserted in diametrically opposed tooth spaces. For a sprocket having an odd number of teeth, measurement shall be made over pins inserted in the two tooth spaces most nearly diametrically opposite with respect to each other. During measurement, the pins shall remain in contact with the root diameter of the corresponding teeth.

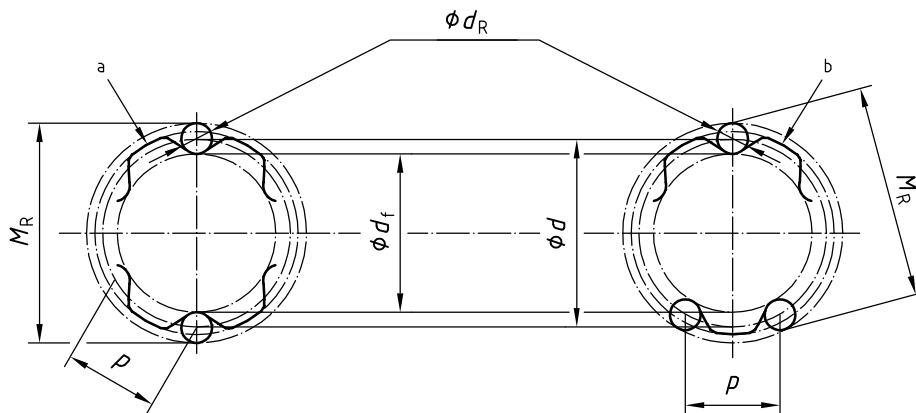

Key

- d pitch circle diameter
- d_f root diameter
- d_R diameter of measuring pins
- M_R measurement over measuring pins
- p chordal pitch, equal to chain pitch
- a Even number of teeth
- b Odd number of teeth

Figure 13 — Measurement over measuring pins

5.2 Tooth gap form

5.2.1 General

The tooth gap form shall have tooth flanks or a profile defined by the tooth flank (topping radius) r_e , the working face length and the bush seating radius r_i , with a smooth blending from one portion to the next.

5.2.2 Working face

The working face is the functional part of the tooth form. It shall not extend beyond the line through the adjacent pitch point which is perpendicular to the working face.

The length of the working face shall be equal to $0,01p \times z$.

NOTE The working face length provides for approximately 6 % chain pitch elongation.

5.2.3 Pressure angle, θ

The pressure angle is the angle between the pitch line of the chain link and the line perpendicular to the working face at the point of bush contact. The pressure angle at any point on the working face shall be in accordance with Table 10.

5.2.4 Pitch diameter factor, p_{cf}

$$p_{cf} = \operatorname{cosec}\left(\frac{180^\circ}{z}\right)$$

Values for p_{cf} are given in Table 10.

5.2.5 Chain clearance diameter and outside diameter factor, d_{gf}

$$d_{gf} = \cot\left(\frac{180^\circ}{z}\right)$$

Values for d_{gf} are given in Table 10.

5.2.6 Pitch line clearance, s

$$s = 0,3 p$$

5.2.7 Bush seating radius, r_i

$$r_i \text{ max.} = 0,5 d_1$$

5.2.8 Tooth flank (topping radius), r_e

$$r_e = 0,5 p$$

5.3 Rim profile

5.3.1 Tooth width, b_f

$$b_f \text{ max.} = 0,95 b_1$$

Values for b_1 are given in Table 1.

Table 10 — Pitch diameter factor, chain clearance diameter and outside diameter factor and pressure angles

Number of teeth	Pitch diameter factor	Chain clearance diameter and outside diameter factor	Pressure angle	Number of teeth	Pitch diameter factor	Chain clearance diameter and outside diameter factor	Pressure angle
z	P_{cf}	d_{gf}	θ°	z	P_{cf}	d_{gf}	θ°
6	2,000	1,73	9	21	6,709	6,63	22
7	2,304	2,07	10	22	7,026	6,95	22
8	2,613	2,41	11	23	7,343	7,27	22
9	2,923	2,74	12	24	7,661	7,59	23
10	3,236	3,07	13	25	7,978	7,91	23
11	3,549	3,40	14	26	8,296	8,23	23
12	3,863	3,73	15	27	8,613	8,55	23
13	4,178	4,05	16	28	8,931	8,87	24
14	4,494	4,38	17	29	9,294	9,19	24
15	4,809	4,70	18	30	9,566	9,51	24
16	5,125	5,03	19	31	9,884	9,83	24
17	5,442	5,35	20	32	10,202	10,15	24
18	5,758	5,67	20	33	10,520	10,47	25
19	6,075	5,99	21	34	10,837	10,79	25
20	6,392	6,31	21	35	11,156	11,11	25
				36	11,473	11,43	25

5.3.2 Tooth side relief, b_a

$$b_a = 0,12 b_f$$

b_a shall not exceed 9,6 mm.

5.3.3 Maximum chain clearance diameter, d_g

$$d_g = p (d_{gf} - 0,05) - h_2$$

The circle corresponding to this diameter defines the limit beyond which no portion of the hubs, beads, lugs or fillets shall extend in the proximity of the chain side plates.

5.4 Tolerances

5.4.1 Radial run-out

The radial run-out between the bore and the root diameter shall not exceed the values given in Table 11.

5.4.2 Axial run-out

The axial run-out, measured with reference to the bore and the flat part of the side face of the teeth, shall not exceed the values given in Table 11.

5.4.3 Bore

Unless otherwise specified by agreement between the manufacturer and purchaser, bores shall be machined to the H9 limits specified in ISO 286-2.

Table 11 — Tolerances

Dimensions in millimetres

Pitch circle diameter <i>d</i>	Root diameter radial run-out	Tooth side face axial run-out
< 305	1,524	2,286
305 to 609	3,048	3,81
610 to 914	5,08	5,334
915 to 1 219	7,62	6,858
1 220 to 1 524	8,382	8,382
1 525 to 1 830	9,144	9,906

NOTE Tolerances relating to pitch circle diameters greater than 1 830 mm should be obtained from the manufacturer.

5.5 Marking

It is recommended that sprockets be marked with the following information:

- a) manufacturer's name or trademark;
- b) number of teeth;
- c) ISO chain number (see Table 1).

.....

ICS 21.220.30

Price based on 18 pages

© ISO 2002 – All rights reserved