International Standard



6933

INTERNATIONAL ORGANIZATION FOR STANDARDIZATION • МЕЖДУНАРОДНАЯ ОРГАНИЗАЦИЯ ПО СТАНДАРТИЗАЦИИ • ORGANISATION INTERNATIONALE DE NORMALISATION

Railway rolling stock material — Magnetic particle acceptance testing

Matériel roulant de chemin de fer — Essai de réception magnétoscopique

First edition — 1986-06-01

UDC 629.4.02 : 620.179.4

Ref. No. ISO 6933-1986 (E)

Descriptors : railway equipment, railway rolling stock, steel products, axles, wheels, tests, magnetic tests, acceptance testing.

Foreword

ISO (the International Organization for Standardization) is a worldwide federation of national standards bodies (ISO member bodies). The work of preparing International Standards is normally carried out through ISO technical committees. Each member body interested in a subject for which a technical committee has been established has the right to be represented on that committee. International organizations, governmental and non-governmental, in liaison with ISO, also take part in the work.

Draft International Standards adopted by the technical committees are circulated to the member bodies for approval before their acceptance as International Standards by the ISO Council. They are approved in accordance with ISO procedures requiring at least 75 % approval by the member bodies voting.

International Standard ISO 6933 was prepared by Technical Committee ISO/TC 17, *Steel*.

Users should note that all International Standards undergo revision from time to time and that any reference made herein to any other International Standard implies its latest edition, unless otherwise stated.

Railway rolling stock material — Magnetic particle acceptance testing

1 Scope and field of application

1.1 This International Standard specifies a method and procedure for detection of surface discontinuities by means of magnetic particle acceptance testing of railway rolling stock material such as axles and wheels (see ISO 1005/3 and ISO 1005/6).

1.2 Unless otherwise agreed, this International Standard shall be applied when magnetic particle tests are agreed or specified for products to be delivered in accordance with the various parts of ISO 1005.

2 References

ISO 1005, *Railway rolling stock material* —

Part 3 : Axles for tractive and trailing stock — Quality requirements.

Part 6 : Solid wheels for tractive and trailing stock — Quality requirements.

3 Information to be supplied by the purchaser

Where magnetic particle acceptance tests are to be carried out the purchaser shall, where applicable, state on his enquiry and order

- a) which surface areas shall be inspected and the appropriate direction of magnetic field as given in table 2;
- b) whether, in the case of axles, a demagnetization of the products is required (see clause 9).

4 General requirements

When magnetic particle tests are specified for the acceptance of the products, these shall be carried out at the manufacturer's works by competent staff, and, if so requested, in the presence of a representative of the railway.¹⁾

5 Main characteristics of the equipment; inks and testing procedure

5.1 Survey

Table 1 gives a survey of the main testing variables permitted by this clause provided that the requirements for sensitivity setting in clause 6 are complied with.

5.2 Testing equipment and recommendations for use

The testing equipment shall be suitable for performing the following operations :

- magnetization (see 5.2.1)
- application of magnetic particles (see 5.2.2)
- observation with suitable lighting (see 5.2.3)
- where required (see clause 9), demagnetization (see 5.2.4).

5.2.1 Magnetization facilities and methods

5.2.1.1 Magnetization facilities

The magnetization facilities shall be suitable for the application of one of the following basic magnetization methods :

- a) the current flow method (see 5.2.1.2);
- b) the magnetic flux method (see 5.2.1.3 and also 5.4).

5.2.1.2 Current flow method

Magnetization is achieved by passing an electric current, by means of electrodes, of such an intensity that at each extremity of the region to be tested [see figure 1 a)] the requirements for sensitivity setting (see clause 6) are complied with. Precautions shall be taken to avoid arcing at the contacts by using electric conductor pads and by switching off the current before withdrawing the pads.

1) Here and throughout the text, "representative of the railway" should be understood to mean the representative of the railway administration.

The current is supplied by a transformer which may be also fitted with a rectifier, so that the current passing through the product may be alternating, pulsating or of the impulse current type (with at least three impulses).

Direct current may also be used. The circuit shall incorporate a suitable device for the regulation and measurement of the current. This method produces a magnetic field perpendicular to the line between the electrodes.

5.2.1.3 Magnetic flux method (coil or yoke method)

5.2.1.3.1 The magnetization of the area to be examined is achieved in this case by a magnetic field produced by a coil (see 5.2.1.3.2) or by a yoke (see 5.2.1.3.3).

5.2.1.3.2 In the case of the coil method, the magnetization is achieved by the use of an insulated cable, connected to a transformer of the type described in 5.2.1.2, which encircles the product or is threaded through the bore of the wheel or partially encircles a rotating wheel [see figure 1 b), and figure 2 a), b) and c)]. The magnetization shall be such that the requirements in clause 6 are complied with. The cable should be positioned as near to the part as possible to ensure maximum magnetic field strength.

5.2.1.3.3 In the case of the yoke method, the magnetization is achieved by a pair of electromagnets, or by a pair of permanent magnets or by a "horse-shoe" permanent magnet. In each of these cases the opposing poles are placed astride the area to be tested [see figure 1 c) and d), and figure 2 d) and e)]. Care shall be taken that close contact is established between the poles and the part being tested.

5.2.2 Equipment for the application of magnetic particles

The equipment for application of the inks carrying the magnetic particles (see 5.3) shall ensure a uniform distribution on the product without disturbing the indication produced. The equipment should also have a device such as a stirrer to keep the particles uniformly distributed in the ink.

The equipment used for the application and distribution of the inks on the surface of the product shall not be of ferromagnetic material.

5.2.3 Lighting facilities

Depending on whether fluorescent and/or non-fluorescent magnetic particles are used for the inspections (see 5.3.2), the equipment shall be provided with lighting facilities as follows :

- ultraviolet light radiating mainly in the wavelength range 330 to 390 nm with an irradiance measured at the surface to be examined of $\geq 5 \text{ W/m}^2$ at 365 nm and/or
- normal light radiating with an illuminance (measured at the surface to be tested) of $\geq 500 \text{ lx}$.

When using ultraviolet light, white light should be reduced to that sufficient for safety, say about 10 lx, or use can be made of a dull amber light similar to that used in photographic dark-rooms.

NOTE — 500 lx is equivalent to bright daylight or to artificial light from a fluorescent tube of 80 W at a distance of 1 m or from a tungsten lamp of 100 W at a distance of 0,2 m.

5.2.4 Demagnetization equipment

The demagnetization equipment shall be capable of reducing the residual magnetism to the necessary level for the intended use of the part (see clause 9).

5.3 Magnetic particle materials (inks)

5.3.1 General

The magnetic particle materials are usually supplied as proprietary products and should be used according to the manufacturer's instructions.

5.3.2 Types of inks

The inks can be classified into the following types :

5.3.2.1 Magnetic crack detection inks consisting of magnetic particles suspended in a carrier liquid. This type of ink may be used for machined parts.

5.3.2.2 Fluorescent crack detection inks consisting of magnetic particles coated with a fluorescent material and suspended in a carrier liquid. Observation is carried out under illumination from an ultraviolet lamp (see 5.2.3).

5.3.3 Properties of inks

5.3.3.1 As carrier liquid, kerosene or water shall be used. The liquid should not corrode the surface of the steel and should have low surface tension. Therefore, in the case of water, anti-corrosives and wetting agents may be included as required.

5.3.3.2 The ferromagnetic particles to be added to the carrier liquid shall be of such nature that they can easily be kept in suspension in the carrier liquid.

The proportion of carrier liquid to magnetic particles in the ink shall be in accordance with the recommendations of the manufacturer of the magnetic particles.

At appropriate time intervals, for example at the beginning of each shift, the consistency of the inks shall be checked. These checks shall preferably be carried out by comparing the indications produced on a test piece by a fresh ink with those produced by the ink already used.

5.3.3.3 The inks shall be kept free of dirt or other foreign matter that might impair the effectiveness of the inspection.

5.4 Application of the ink

According to the method of application of the ink it is possible to differentiate between two procedures :

- a) the continuous procedure, in which the inks are applied during magnetization, i.e. while the full magnetic field is still effective;
- b) the remanent procedure, in which the inks are applied after magnetization of the component so that only the residual magnetic field becomes effective.

In case a), the magnetization shall be maintained for at least 1 s after the application of the ink, so that the formation of indications is not impaired by flowing ink.

Case b) may be applied only if the magnetization is carried out

- with direct current with a current duration of $\geq 1/4$ s
- with at least three current impulses of a duration of $\geq 1/120$ s per impulse
- or with a permanent magnet.

6 Sensitivity setting

6.1 General

6.1.1 Sensitivity setting shall be carried out using a component with the same dimensions, the same surface condition (see clause 7) and heat treatment condition and of the same steel type as those to be inspected. The component may consequently be one of the components in the delivery to be inspected.

6.1.2 The testing conditions applied during sensitivity setting shall be in accordance with one of the alternatives specified in clause 5 and table 1 and shall [with the exception of the variable(s) used for sensitivity setting] be the same as those intended for the inspection of the components.

The sensitivity shall be set so that the magnetic field strength measured at any spot on the area to be inspected parallel to the main flux direction (see table 2) is 2 000 A/m minimum.

The field strength measurement shall be carried out with a calibrated instrument. In cases of dispute, a Hall generator shall be applied.

Reference test pieces made of similar steels to those being tested and having known defects in their surface may also be applied for checking the sensitivity, provided that they comply with the above requirements.

In cases of dispute, the correct sensitivity setting shall be verified by field strength measurements.

7 Surface areas to be examined and surface condition and preparation

7.1 When magnetoscopic acceptance tests are required, they shall be carried out in accordance with table 2 [see also 3 a)].

7.2 The surface to be inspected shall be essentially scale-free to ensure that discontinuities which may give cause for rejection are revealed (see 8.4).

Grease, dirt, paint and other coatings on the surface of the product shall be removed.

7.3 If the material has been magnetized it may be necessary to demagnetize it prior to testing.

8 Testing

8.1 Testing conditions

Testing shall be carried out under conditions which have proved compatible with the sensitivity requirements in 6.2 and are in accordance with clause 5 and table 1.

Care shall be taken during testing that the surface to be examined is uniformly coated with ink and that particle patterns on the surface to be examined are not disturbed before inspection.

8.2 Interpretation of the magnetic particle indications

The observation of magnetic particle indications should be performed immediately after their formation.

Not all magnetic particles indications necessarily represent discontinuities and it is necessary, therefore, to take account of this when preparing acceptance criteria (see the note).

Indications believed to be spurious should be retested after cleaning the surface.

If indications reappear after retests, these indications may be further examined to reveal their nature.

NOTE — Product specifications allow the presence of a small number of fine discontinuities made visible by this test method.

8.3 Test report

Relevant indications consisting of either build-up of powder or fluorescent lines shall be measured and their number, size and position shall be recorded in accordance with the product specification or order requirements together with the following information :

- a) date of testing;
- b) place of testing;
- c) symbols for the product and material such as the product and material designation, order number, drawing number, heat number, and piece number;
- d) test conditions :
 - 1) test equipment (designation, type, name of the manufacturer),

- 2) magnetizing method,
 - 3) nature of the magnetizing current (moreover, in the case of pulsating current, the rectifying method shall be recorded),
- Example* : Pulsating current, single-phase half-wave rectifying method.
- 4) nature of the magnetic particles (name of the manufacturer and type number),
 - 5) carrier liquid for the magnetic particles,
 - 6) method of application of the magnetic particles,
 - 7) type of sensitivity setting (designation of the reference test piece or any other method used).

8.4 Acceptance criteria

The acceptance criteria shall take into account the test conditions, the service conditions for which the products are intended and, as far as possible, the position, shape, size, orientation and distribution of the discontinuities and shall be agreed at the time of enquiry and order (see 8.2).

9 Demagnetization

If specified in the order, axles which are accepted and exhibit residual magnetism which is too strong shall be demagnetized. Where appropriate the order shall define the permissible residual magnetic field strength of the component.

NOTE — Axles which are to be used with roller bearings should be demagnetized.

Table 1 — Survey of the main testing variables permitted by this International Standard

	Alternative methods or conditions	Subclause	
Magnetization	a) current flow method b) magnetic flow method 1) coil method 2) yoke method — with electromagnets — with permanent magnets	with — alternating current — pulsating current — impulse current (with ≥ 3 impulses) — direct current	5.2.1
Timing of the application of the ink	Application during magnetization (= continuous procedure) Application after magnetization (= remanent procedure)	only applicable for magnetization with — direct current — impulse current — permanent magnets	5.4
Magnetic particle materials (inks)	Fluorescent inks Non-fluorescent inks (only applicable for machined surfaces)		5.3
Light conditions	Ultraviolet light, of wavelengths lying mainly in the 330 to 390 nm region, irradiance ≥ 5 W/m ² at 365 nm Normal light (only applicable for machined surfaces)		5.2.3

Table 2 — Surface areas to be inspected and direction of magnetization

Component	Surface areas to be inspected	Direction of field of magnetization*	Direction of discontinuity for which examination is being made	Magnetizing method
Solid wheels	Web	radial	circumferential	Figure 2 a), c) and d)
		circumferential	radial	Figure 2 b), c) and e)
Axles	Whole circumference	axial	transverse	Figure 1 b) and c)
		circumferential	axial	Figure 1 a) and d)

* In order to detect a discontinuity, the direction of the magnetic field should be normal (at right angles) to the discontinuity.

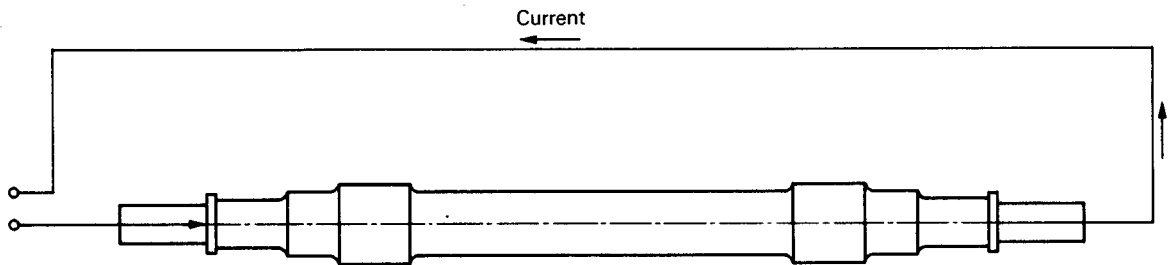

a) Current flow method

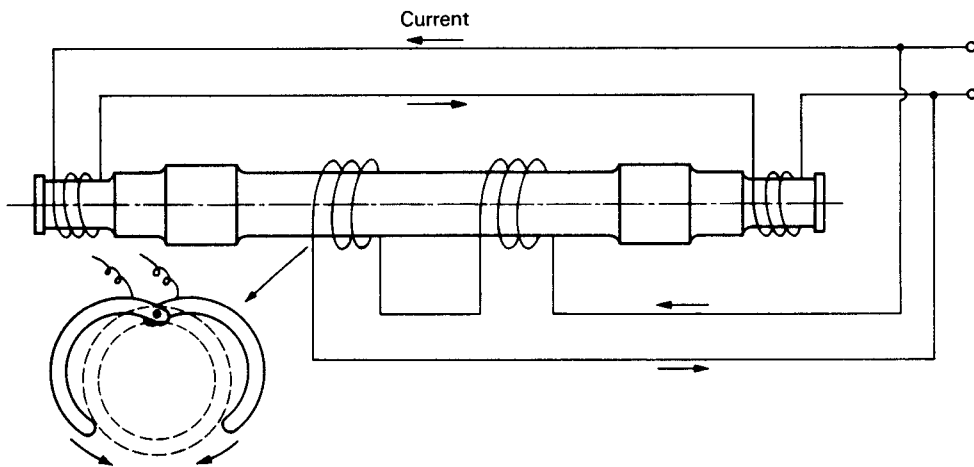

b) Coil method

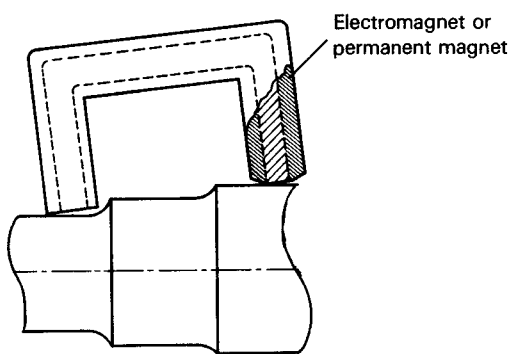

c) Yoke method

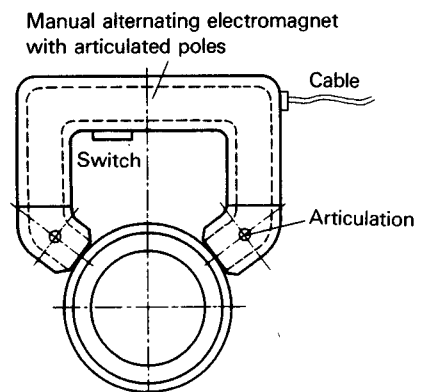

d) Yoke method

Figure 1 – Axle acceptance tests

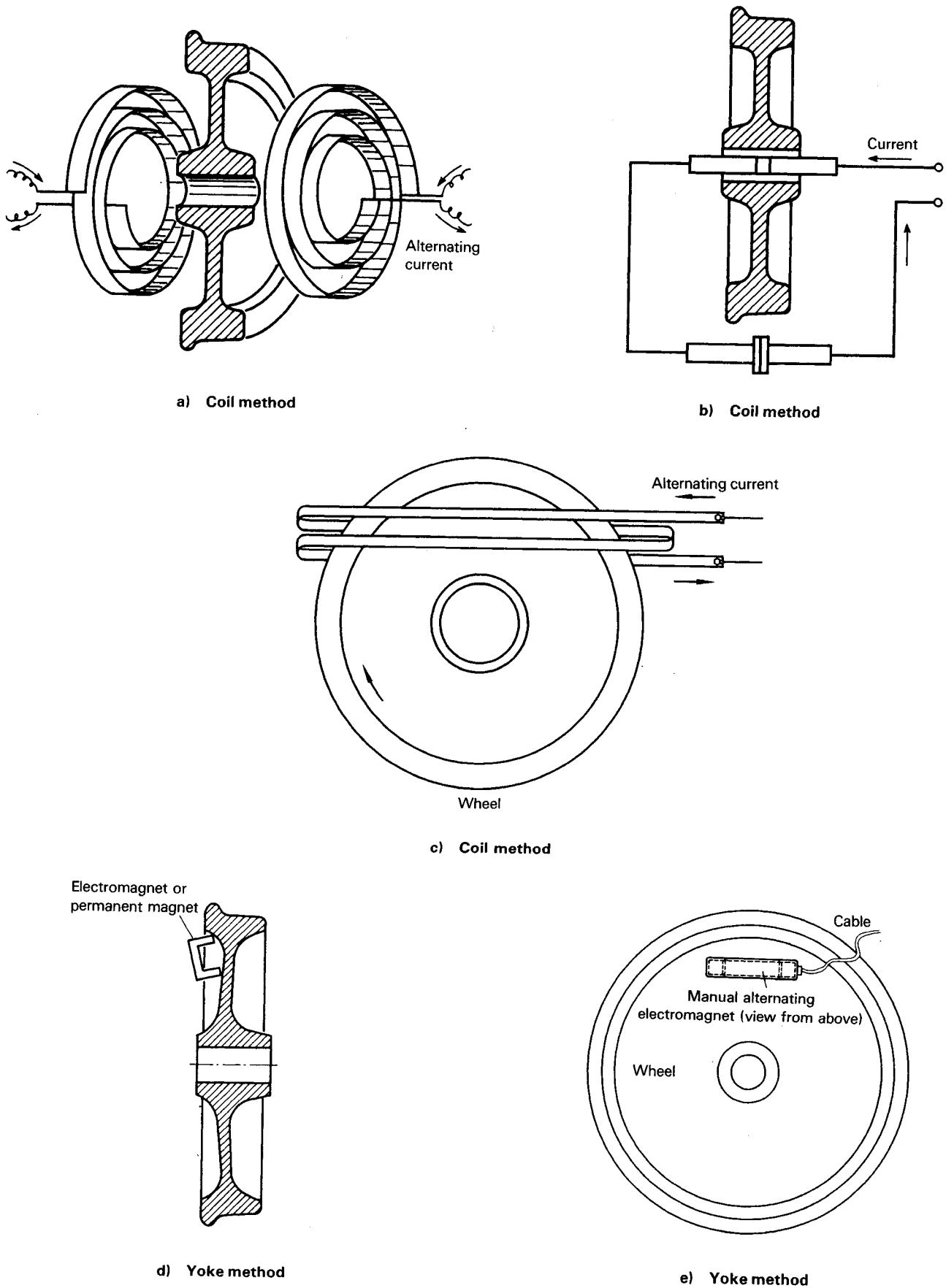

Figure 2 – Wheel acceptance tests