

# INTERNATIONAL STANDARD

**ISO**  
**6894**

Second edition  
1991-04-15

---

---

## **Rubber compounding ingredients — Carbon black — Preparation of samples for determination of dibutylphthalate absorption number (compressed sample)**

*Ingrédients de mélange du caoutchouc — Noir de carbone —  
Préparation d'échantillons pour détermination de l'indice d'absorption  
de phtalate de dibutyle (échantillon comprimé)*



Reference number  
ISO 6894:1991(E)

## Foreword

ISO (the International Organization for Standardization) is a worldwide federation of national standards bodies (ISO member bodies). The work of preparing International Standards is normally carried out through ISO technical committees. Each member body interested in a subject for which a technical committee has been established has the right to be represented on that committee. International organizations, governmental and non-governmental, in liaison with ISO, also take part in the work. ISO collaborates closely with the International Electrotechnical Commission (IEC) on all matters of electrotechnical standardization.

Draft International Standards adopted by the technical committees are circulated to the member bodies for voting. Publication as an International Standard requires approval by at least 75 % of the member bodies casting a vote.

International Standard ISO 6894 was prepared by Technical Committee ISO/TC 45, *Rubber and rubber products*.

This second edition cancels and replaces the first edition (ISO 6894:1984), sub-clauses 7.1.5, 7.1.8 and 7.2.3 of which have been technically revised.

© ISO 1991

All rights reserved. No part of this publication may be reproduced or utilized in any form or by any means, electronic or mechanical, including photocopying and microfilm, without permission in writing from the publisher.

International Organization for Standardization  
Case Postale 56 • CH-1211 Genève 20 • Switzerland

Printed in Switzerland

# Rubber compounding ingredients — Carbon black — Preparation of samples for determination of dibutylphthalate absorption number (compressed sample)

## 1 Scope

This International Standard specifies procedures for the preparation of samples for the determination of the dibutylphthalate absorption number of compressed samples of carbon black for use in the rubber industry.

## 2 Normative references

The following standards contain provisions which, through reference in this text, constitute provisions of this International Standard. At the time of publication, the editions indicated were valid. All standards are subject to revision, and parties to agreements based on this International Standard are encouraged to investigate the possibility of applying the most recent editions of the standards indicated below. Members of IEC and ISO maintain registers of currently valid International Standards.

ISO 1126:1985, *Rubber compounding ingredients — Carbon black — Determination of loss on heating*.

ISO 4656-1:1985, *Rubber compounding ingredients — Carbon black — Determination of dibutylphthalate absorption number — Part 1: Method using absorptometer*.

ISO 4656-2:1981, *Rubber compounding ingredients — Carbon black — Determination of dibutylphthalate absorption number — Part 2: Method using plastograph or plasticorder*.

ISO 6809:1989, *Rubber compounding ingredients — Carbon black — Standard reference blacks*.

## 3 Principle

A quantity of dry carbon black is compressed four times at a pressure of 165 MPa, and then the dibutylphthalate absorption number is determined as described in ISO 4656-1 or ISO 4656-2.

## 4 Apparatus

4.1 **Balance**, accurate to 0,01 g.

4.2 **Oven**, gravity-convection type, capable of being maintained at  $105\text{ °C} \pm 2\text{ °C}$  or  $125\text{ °C} \pm 2\text{ °C}$ .

4.3 **Compression cylinder and piston** (type A or B).

For essential features see figure 1 and figure 2.

4.4 **Hydraulic press**, electrically operated, having sufficient power to force the piston into the cylinder during compression of the sample at a rate of 4,2 mm/s and to attain a final pressure of 165 MPa on the sample.

4.5 **Spatula**.

4.6 **Steel beaker**.

4.7 **Brush**, 38 mm stiff bristle.

4.8 **Desiccator**.

## 5 Sample preparation

Dry an adequate amount of the sample of carbon black in the oven (4.2), maintained at  $105\text{ °C} \pm 2\text{ °C}$  or  $125\text{ °C} \pm 2\text{ °C}$ , for 1 h. Allow to cool to ambient temperature in the desiccator (4.8).

## 6 Conditions of test

This test should preferably be carried out under ambient conditions of either  $23\text{ °C} \pm 2\text{ °C}$  and  $(50 \pm 5)\%$  relative humidity or  $27\text{ °C} \pm 2\text{ °C}$  and  $(65 \pm 5)\%$  relative humidity.

## 7 Procedures

### 7.1 Procedure using the type A apparatus (figure 1)

7.1.1 Place the bottom seal plate and the compression cylinder (4.3) in the correct position in the hydraulic press (4.4). Move the handle of the seal plate to check its position in the support plate. Rotate the cylinder to be certain it fits on the seal plate.

7.1.2 Weigh out  $25\text{ g} \pm 0,1\text{ g}$  of the dried sample (see clause 5).

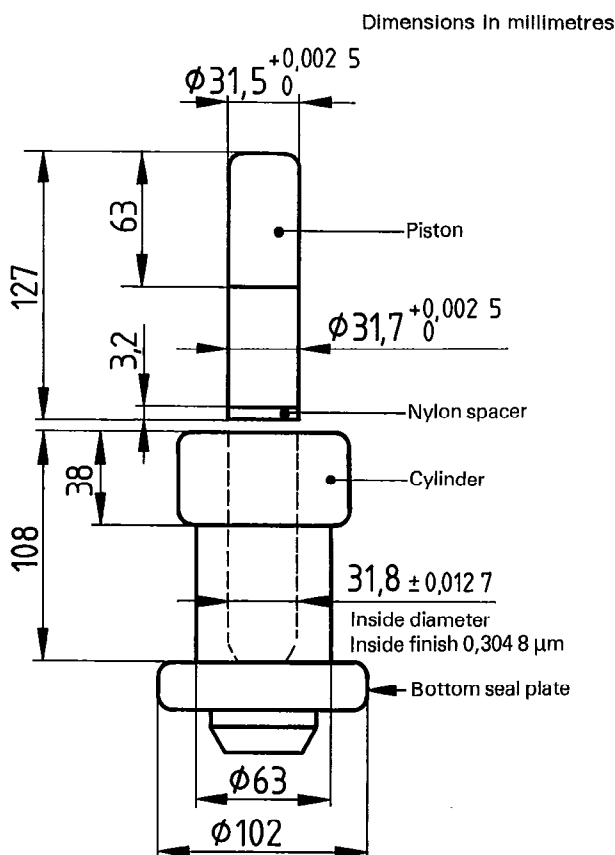

Figure 1 — Essential features of type A compression cylinder and piston

7.1.3 Pour this sample into the compression cylinder.

7.1.4 Place the piston in the cylinder with the nylon spacer next to the carbon black. Rotate the piston slightly while pressing it by hand into the cylinder as far as possible.

7.1.5 Adjust alignment of the piston, cylinder and power ram to maintain freedom of movement.

7.1.6 Compress the black to 165 MPa. Make certain full pressure is applied, hold for 1 s, then release.

NOTE 1 The oil gauge pressure level is dependent on the bore diameter of the hydraulic cylinder and the surface area of the end of the ram. In order to compress the black to 165 MPa (24 000 psi), the required oil pressure for the ENERPAC RC256<sup>1)</sup> single-acting cylinder is 5 710 psi and for the double-acting RR308<sup>1)</sup> it is 4 357 psi, giving 131 kN (29 450 lbf) on the piston of 7,916 cm<sup>2</sup> (1,227 in<sup>2</sup>) area.

7.1.7 Raise the power ram enough to remove the bottom seal plate; then lower the ram to press the piston and sample through the cylinder into the steel beaker (4.6).

7.1.8 Wipe the cylinder, piston and bottom seal plate free of carbon black dust and replace the bottom seal plate and cylinder in the press stand as described in 7.1.1.

7.1.9 Break up the sample with the spatula (4.5) so that the largest agglomerate is 0,25 cm. Ensure that no sample is lost during this procedure.

7.1.10 Repeat 7.1.4 to 7.1.9, compressing the sample a total of four times. Retain the sample after the fourth compression.

If the compressed sample is not to be tested within 15 min after compression, store it in the desiccator (4.8), or redry it for 1 h at 105 °C or 125 °C as specified in clause 5, prior to testing.

7.1.11 Weigh, to the nearest 0,01 g,  $20\text{ g} \pm 0,02\text{ g}$  of the compressed sample (all grades) and determine its dibutylphthalate absorption number in accordance with ISO 4656-1 or ISO 4656-2.

Data on the dibutylphthalate absorption number of a compressed sample of standard reference black are given in ISO 6809.

It is important to check results obtained on a standard reference black known to be near to that of the sample to ensure that the result is within the required range.

1) ENERPAC RC256 and RR308 are examples of suitable equipment available commercially. This information is given for the convenience of users of this International Standard and does not constitute an endorsement by ISO of this equipment.

Dimensions in millimetres

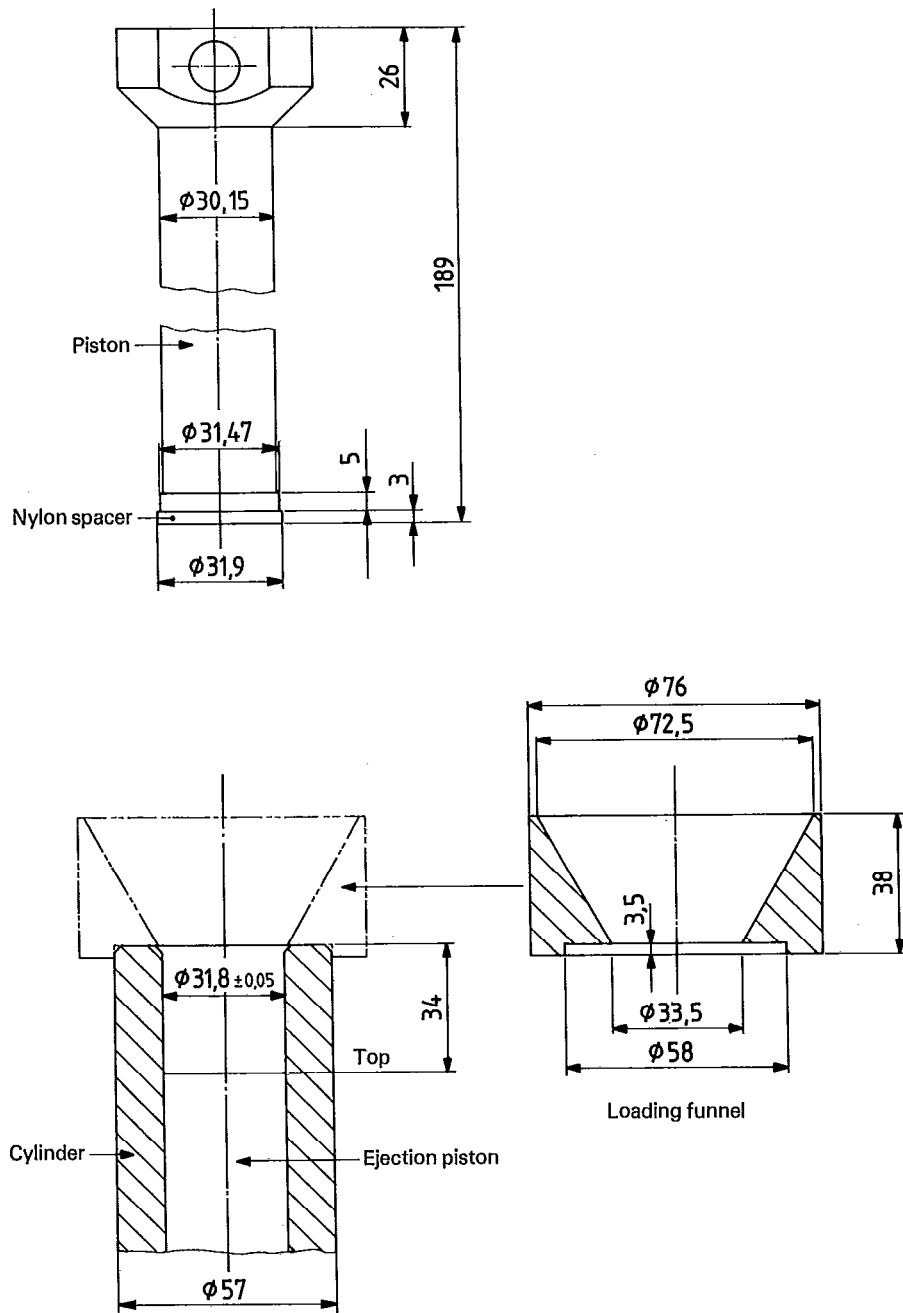

Figure 2 — Essential features of type B compression cylinder and piston

## 7.2 Procedure using the type B apparatus (figure 2)

7.2.1 Weigh out  $25 \text{ g} \pm 0,1 \text{ g}$  of the dried sample (see clause 5).

7.2.2 Pour the sample into the compression cylinder.

7.2.3 Compress the black to 165 MPa by operating the ram using a downward movement to open the right-hand valve. Press until the gauge located above the apparatus reaches 103 MPa (15 000 psi) and release immediately.

NOTE 2 The oil gauge pressure level is dependent on the base diameter of the hydraulic cylinder and the cross-sectional area of the piston. For this apparatus, 103 MPa (15 000 psi) on the gauge exerts 165 MPa on the piston.

7.2.4 Raise the ram by operating the right-hand valve in an upwards direction. Continue until the ram is approximately 4 cm clear of the cylinder, i.e. level with the top of the conical collar.

7.2.5 Raise the cylinder piston by operating the left-hand valve in an upwards direction. Continue until the compressed sample is clear of the cylinder and is broken by contact with the raised ram. The sample will fall into the conical collar.

7.2.6 Break up the sample with a spatula so that the largest agglomerate is 0,25 cm. Ensure that no sample is lost during this procedure.

7.2.7 Lower the piston and allow the sample to fall back into the cylinder. If necessary, brush the inside of the collar with the brush (4.7) to return all of the black to the cylinder.

7.2.8 Repeat steps 7.2.3 to 7.2.7 on a further two occasions.

7.2.9 Remove the collar and repeat step 7.2.3 once again.

7.2.10 Raise the ram to its top position using the right-hand valve control.

7.2.11 Push the sample out of the cylinder by raising the piston using the left-hand valve control.

7.2.12 Return the piston to its low position by using the left-hand valve control.

7.2.13 Transfer the sample to the steel beaker and, using the spatula (4.5), break it down to a maximum agglomerate size of 0,25 cm.

If the compressed sample is not to be tested within 15 min after compression, store it in the desiccator (4.8), or redry it for 1 h at 105 °C or 125 °C, as specified in clause 5, prior to testing.

7.2.14 Weigh, to the nearest 0,01 g,  $20 \text{ g} \pm 0,02 \text{ g}$  of the compressed sample (all grades) and determine its dibutylphthalate absorption number in accordance with ISO 4656-1 or ISO 4656-2.

Data on the dibutylphthalate number of a compressed sample of standard reference black are given in ISO 6809.

It is important to check results obtained on a standard reference black known to be near to that of the sample to ensure that the result is within the required range.

## 8 Expression of results

Express the results as indicated in ISO 4656-1 or ISO 4656-2.

## 9 Test report

The test report shall include the following information:

- a) a reference to this International Standard;
- b) all details necessary for the complete identification of the sample;
- c) the test conditions, including the drying temperature;
- d) the exact mass of the sample;
- e) the test results as directed in ISO 4656-1 or ISO 4656-2 as appropriate.

---

---

**UDC 678.046.2:620.115**

**Descriptors:** rubber, ingredients, carbon black, tests, determination, absorption factor, dibutyl phthalate, test specimens, specimen preparation.

Price based on 4 pages

---

---