**Plastics hoses and hose assemblies for
suction and low-pressure discharge of
petroleum liquids — Specification**

*Tuyaux et flexibles en plastique pour aspiration et refoulement basse
pression des liquides pétroliers — Spécifications*



Reference number
ISO 6808:2014(E)

© ISO 2014



COPYRIGHT PROTECTED DOCUMENT

© ISO 2014

All rights reserved. Unless otherwise specified, no part of this publication may be reproduced or utilized otherwise in any form or by any means, electronic or mechanical, including photocopying, or posting on the internet or an intranet, without prior written permission. Permission can be requested from either ISO at the address below or ISO's member body in the country of the requester.

ISO copyright office
Case postale 56 • CH-1211 Geneva 20
Tel. + 41 22 749 01 11
Fax + 41 22 749 09 47
E-mail copyright@iso.org
Web www.iso.org

Published in Switzerland

Contents

| | Page |
|--|-----------|
| Foreword | iv |
| Introduction | v |
| 1 Scope | 1 |
| 2 Normative references | 1 |
| 3 Terms and definitions | 2 |
| 4 Classification — Hose types | 2 |
| 5 Construction and materials — Requirements | 2 |
| 6 Dimensions and tolerances | 2 |
| 6.1 Diameter..... | 2 |
| 6.2 Length..... | 3 |
| 7 Physical properties of finished hoses | 3 |
| 7.1 Hydrostatic requirements at standard laboratory temperature..... | 3 |
| 7.2 Hydrostatic requirements at 45 °C..... | 3 |
| 7.3 Change in length (Type 2 only)..... | 4 |
| 7.4 Suction resistance..... | 4 |
| 7.5 Reinforcement fracture..... | 4 |
| 7.6 Minimum bend test..... | 5 |
| 7.7 Cold bend test..... | 5 |
| 7.8 Electrical continuity..... | 5 |
| 8 Physical properties of the flexible thermoplastics material | 5 |
| 8.1 Loss in mass on heating..... | 5 |
| 8.2 Tensile strength and elongation at break..... | 5 |
| 8.3 Fuel resistance..... | 6 |
| 8.4 Oil resistance..... | 6 |
| 8.5 Resistance to accelerated ageing..... | 6 |
| 9 Hose assemblies | 7 |
| 9.1 Couplings and method of attachment..... | 7 |
| 9.2 Test for security of coupling..... | 7 |
| 9.3 Electrical bonding..... | 7 |
| 9.4 Electrical wall resistance..... | 7 |
| 10 Frequency of testing | 7 |
| 11 Type tests | 8 |
| 12 Marking | 8 |
| 12.1 Hoses..... | 8 |
| 12.2 Hose assemblies..... | 8 |
| Annex A (normative) Test frequency | 9 |
| Annex B (informative) Production tests | 10 |
| Annex C (normative) Reinforcement fracture test | 11 |
| Annex D (normative) Coupling security test | 13 |
| Bibliography | 14 |

Foreword

ISO (the International Organization for Standardization) is a worldwide federation of national standards bodies (ISO member bodies). The work of preparing International Standards is normally carried out through ISO technical committees. Each member body interested in a subject for which a technical committee has been established has the right to be represented on that committee. International organizations, governmental and non-governmental, in liaison with ISO, also take part in the work. ISO collaborates closely with the International Electrotechnical Commission (IEC) on all matters of electrotechnical standardization.

The procedures used to develop this document and those intended for its further maintenance are described in the ISO/IEC Directives, Part 1. In particular the different approval criteria needed for the different types of ISO documents should be noted. This document was drafted in accordance with the editorial rules of the ISO/IEC Directives, Part 2 (see www.iso.org/directives).

Attention is drawn to the possibility that some of the elements of this document may be the subject of patent rights. ISO shall not be held responsible for identifying any or all such patent rights. Details of any patent rights identified during the development of the document will be in the Introduction and/or on the ISO list of patent declarations received (see www.iso.org/patents).

Any trade name used in this document is information given for the convenience of users and does not constitute an endorsement.

For an explanation on the meaning of ISO specific terms and expressions related to conformity assessment, as well as information about ISO's adherence to the WTO principles in the Technical Barriers to Trade (TBT) see the following URL: Foreword - Supplementary information

The committee responsible for this document is ISO/TC 45, *Rubber and rubber products*, Subcommittee SC 1, *Rubber and plastics hoses and hose assemblies*.

This third edition cancels and replaces the second edition (ISO 6808:1999), which has been technically revised with the following changes:

- Throughout the document: Nominal bore was changed to hose size.
- Throughout the document: ISO 1817 Oil No. 3 was changed to IRM 903 oil.
- ISO 471, ISO 1746, and ISO 4672 were replaced by ISO 23529, ISO 10619-1, and ISO 10619-2, respectively.
- Terms and definitions clause was added.
- Type 1 and Type 2 maximum working pressures at 45 °C were corrected.
- Hose construction for electrical bonding was updated.
- [Tables 4](#) and [5](#): Note b was added.
- [7.2](#) and [Table 5](#): Changed 55 °C to 45 °C.
- [9.3](#): Electrical bonding was redefined.
- [9.4](#): Added electrical wall resistance clause.
- Added frequency of testing clause.
- Added type tests clause.
- Added [Annex A](#) — Test frequency.
- Added [Annex B](#) — Production tests.

Introduction

This International Standard has been prepared to provide minimum acceptable requirements for the satisfactory performance of polymer-reinforced thermoplastics hoses for suction and discharge applications, conveying kerosene, heating oil, diesel fuel, and lubricating oils. These hoses are neither suitable for conveying automotive or aviation fuel nor suitable for metered delivery of any liquid.

The list of hose sizes given in [Tables 1](#) and [2](#) is not intended to be restrictive and will not preclude the manufacture of sizes outside the preferred-number range (the basis of the tables) and which might be the subject of individual national standards.

Plastics hoses and hose assemblies for suction and low-pressure discharge of petroleum liquids — Specification

WARNING — Persons using this International Standard should be familiar with normal laboratory practice. This International Standard does not purport to address all of the safety problems, if any, associated with its use. It is the responsibility of the user to establish appropriate safety and health practices and to ensure compliance with any national regulatory conditions.

1 Scope

This International Standard specifies the requirements for two types of polymer-reinforced thermoplastics hose and hose assembly for suction and discharge applications with kerosene, heating oil, diesel fuel, and lubricating oils in the temperature range $-10\text{ }^{\circ}\text{C}$ to $+45\text{ }^{\circ}\text{C}$.

NOTE The hoses can be stored in a static condition at $-30\text{ }^{\circ}\text{C}$ to $+65\text{ }^{\circ}\text{C}$ without damage by climatic conditions.

2 Normative references

The following documents, in whole or in part, are normatively referenced in this document and are indispensable for its application. For dated references, only the edition cited applies. For undated references, the latest edition of the referenced document (including any amendments) applies.

ISO 176:2005, *Plastics — Determination of loss of plasticizers — Activated carbon method*

ISO 188, *Rubber, vulcanized or thermoplastic — Accelerated ageing and heat resistance tests*

ISO 527-3, *Plastics — Determination of tensile properties — Part 3: Test conditions for films and sheets*

ISO 868, *Plastics and ebonite — Determination of indentation hardness by means of a durometer (Shore hardness)*

ISO 1307, *Rubber and plastics hoses — Hose sizes, minimum and maximum inside diameters, and tolerances on cut-to-length hoses*

ISO 1402, *Rubber and plastics hoses and hose assemblies — Hydrostatic testing*

ISO 1817, *Rubber, vulcanized or thermoplastic — Determination of the effect of liquids*

ISO 7233, *Rubber and plastics hoses and hose assemblies — Determination of resistance to vacuum*

ISO 7751, *Rubber and plastics hoses and hose assemblies — Ratios of proof and burst pressure to maximum working pressure*

ISO 8031, *Rubber and plastics hoses and hose assemblies — Determination of electrical resistance and conductivity*

ISO 8330, *Rubber and plastics hoses and hose assemblies — Vocabulary*

ISO 10619-1, *Rubber and plastics hoses and tubing — Measurement of flexibility and stiffness — Part 1: Bending tests at ambient temperature*

ISO 10619-2:2011, *Rubber and plastics hoses and tubing — Measurement of flexibility and stiffness — Part 2: Bending tests at sub-ambient temperatures*

ISO 23529, *Rubber — General procedures for preparing and conditioning test pieces for physical test methods*

3 Terms and definitions

For the purposes of this document, the terms and definitions given in ISO 8330 apply.

4 Classification — Hose types

Two types of hose are specified, differentiated by the maximum working pressure as follows:

- Type 1: for light service, having a maximum working pressure of 0,3 MPa (3 bar) at 23 °C ± 2 °C and 0,07 MPa (0,7 bar) at 45 °C ± 2 °C;
- Type 2: for normal service, having a maximum working pressure of 0,55 MPa (5,5 bar) through hose size 25 and 0,4 MPa (4 bar) above hose size 25 through hose size 50 at 23 °C ± 2 °C. All sizes have a maximum working pressure of 0,15 MPa (1,5 bar) at 45 °C ± 2 °C.

5 Construction and materials — Requirements

The hoses shall be as uniform as commercially practicable in colour, opacity, and other physical properties. Flexible thermoplastics materials shall be supported inside the material by a helix of polymeric material of a similar molecular structure. The reinforcing and flexible components of the wall shall be fused and free from visible cracks, porosity, foreign inclusions, or other defects causing the hose to be unserviceable. Hose assemblies shall be electrically bonded between couplings. The hose construction shall include at least two flexible metallic bonding wires (with or without a metallic helix) incorporated in the hose between the cover and the lining and shall be bonded to the metal couplings. Refer to 9.3 for testing and requirements for electrical bonding.

The method of ensuring initial electrical continuity shall be the responsibility of the manufacturer and shall be carried out to the satisfaction of the user.

6 Dimensions and tolerances

6.1 Diameter

The hose size and the internal diameter and tolerances shall be in accordance with the values given in [Tables 1](#) and [2](#), which are in accordance with ISO 1307.

Table 1 — Diameters and tolerances (Type 1 hoses)

| Hose size | Inside diameter mm | Tolerance mm |
|-----------|-----------------------|-----------------|
| 12,5 | 12,5 | ±0,75 |
| 16 | 16 | ±0,75 |
| 19 | 19 | ±0,75 |
| 25 | 25 | ±1,25 |
| 31,5 | 31,5 | ±1,25 |
| 38 | 38 | ±1,25 |
| 50 | 50 | ±1,5 |
| 63 | 63 | ±2 |
| 80 | 80 | ±2 |
| 100 | 100 | ±2 |
| 125 | 125 | ±2 |

NOTE For smaller or larger diameters, it is recommended that values be chosen from ISO 1307.

Table 2 — Diameters and tolerances (Type 2 hoses)

| Hose size | Inside diameter mm | Tolerance mm |
|-----------|-----------------------|-----------------|
| 12,5 | 12,5 | ±0,75 |
| 16 | 16 | ±0,75 |
| 19 | 19 | ±0,75 |
| 25 | 25 | ±1,25 |
| 31,5 | 31,5 | ±1,25 |
| 38 | 38 | ±1,25 |
| 50 | 50 | ±1,5 |

NOTE For smaller or larger diameters, it is recommended that values be chosen from ISO 1307.

6.2 Length

The tolerances on cut lengths of hose shall be as given in [Table 3](#).

Table 3 — Tolerances on cut lengths

| Hose size | Tolerance on cut length % |
|------------------------|------------------------------|
| Up to and including 38 | ±1 |
| Over 38 | ±2 |

7 Physical properties of finished hoses

7.1 Hydrostatic requirements at standard laboratory temperature

When tested at standard laboratory temperature as specified in ISO 23529 by the method specified in ISO 1402, the hose shall meet the requirements given in [Table 4](#).

When examined at proof pressure (i.e. 50 % of minimum burst pressure), the hose shall show no evidence of leakage, cracking, abrupt distortion, or electrical continuity damage.

Table 4 — Hydrostatic requirements at standard temperature

| Hose size | Maximum working pressure MPa (bar) | | Minimum burst pressure MPa (bar) | |
|----------------------------------|---------------------------------------|------------|-------------------------------------|---------------------|
| | Type 1 | Type 2 | Type 1 ^a | Type 2 ^b |
| Up to and including 25 | 0,3 (3) | 0,55 (5,5) | 1,2 (12) | 2,8 (28) |
| From 31,5 up to and including 50 | 0,3 (3) | 0,4 (4) | 1,2 (12) | 2 (20) |
| From 63 up to and including 125 | 0,3 (3) | — | 1,2 (12) | — |

^a The burst ratio for Type 1 is 4:1 (in accordance with ISO 7751).

^b The burst ratio for Type 2 is 5:1 (rounded to whole numbers).

7.2 Hydrostatic requirements at 45 °C

When tested at 45 °C ± 2 °C by the method specified in ISO 1402, the hose shall meet the requirements given in [Table 5](#).

Table 5 — Hydrostatic requirements at 45 °C (all hose sizes)

| Maximum working pressure | | Minimum burst pressure | |
|---|------------|------------------------|---------------------|
| MPa (bar) | | MPa (bar) | |
| Type 1 | Type 2 | Type 1 ^a | Type 2 ^b |
| 0,07 (0,7) | 0,15 (1,5) | 0,3 (3) | 0,8 (8) |
| ^a The burst ratio for Type 1 is 4:1 (in accordance with ISO 7751). ^b The burst ratio for Type 2 is 5:1 (rounded to whole numbers). | | | |

7.3 Change in length (Type 2 only)

When tested at 23 °C ± 2 °C and 45 °C ± 2 °C by the method specified in ISO 1402, the length of the hose shall not change by more than 15 %.

NOTE Electrical continuity is also tested at this time (see [7.8](#)).

7.4 Suction resistance

When tested at 23 °C ± 2 °C and 45 °C ± 2 °C in accordance with the method specified in ISO 7233, using an internal pressure (less than atmospheric pressure) of –65 kPa (–0,650 bar) for Type 1 and –80 kPa (–0,800 bar) for Type 2, the hose shall not fail due to collapse or fracture at any point that is more than one diameter distance from the coupling.

In the event of failure closer than one diameter distance to the coupling, the test shall be disregarded and a further test piece shall be tested.

7.5 Reinforcement fracture

7.5.1 When tested in accordance with the method specified in [Annex C](#), extended over the appropriate-size extension block given in [Table 6](#) for 4 mo for a type test, or 336 h ± 2 h for a control test, the helical reinforcement shall be capable of reverse bending without cracking.

7.5.2 When the hose is tested, after immersion in IRM 903 oil as defined in ISO 1817 for $\left(72 \begin{smallmatrix} 0 \\ -2 \end{smallmatrix}\right)$ h at 70 °C ± 1 °C, in accordance with the method specified in [Annex C](#), over the appropriate-size extension piece given in [Table 6](#) for 336 h, the helical reinforcement shall be capable of reverse bending without cracking.

Table 6 — Width of extension block used for reinforcement fracture test

| Hose size | Block width, <i>W</i> mm |
|-----------|-----------------------------|
| 12,5 | 10 |
| 16 | 12 |
| 19 | 16 |
| 25 | 19 |
| 31,5 | 23 |
| 38 | 27 |
| 50 | 31 |
| 63 | 34 |
| 80 | 38 |
| 100 | 44 |
| 125 | 49 |

7.6 Minimum bend test

When tested in accordance with ISO 10619-1 at $23\text{ °C} \pm 2\text{ °C}$ and $45\text{ °C} \pm 2\text{ °C}$, using a diameter of curvature *C* of six times the inside diameter, the hose shall not crack.

7.7 Cold bend test

7.7.1 When tested at $-10\text{ °C} \pm 2\text{ °C}$ in accordance with method B of ISO 10619-2:2011, having been conditioned for 5 h at that temperature and using a diameter of curvature of 20 times the inside diameter, the hose shall not crack.

7.7.2 When tested as in [7.7.1](#), but after immersion at $70\text{ °C} \pm 1\text{ °C}$ in IRM 903 oil for $\left(72 \begin{smallmatrix} 0 \\ -2 \end{smallmatrix}\right)$ h as specified in ISO 1817, the hose shall not crack.

7.8 Electrical continuity

During and after the hydrostatic tests described in [7.1](#), [7.2](#), and [7.3](#), the electrical continuity of each test piece shall be maintained from end to end of the hose.

8 Physical properties of the flexible thermoplastics material

8.1 Loss in mass on heating

When tested in accordance with method B of ISO 176:2005, the flexible thermoplastics material used in the construction shall not have a loss in mass greater than 4 %.

8.2 Tensile strength and elongation at break

When determined in accordance with ISO 527-3, the minimum tensile strength and elongation at break of the flexible thermoplastics material used in the construction shall be as given in [Table 7](#).

Table 7 — Tensile strength and elongation at break

| Tensile strength MPa | Elongation at break % |
|-------------------------|--------------------------|
| 7 | 200 |

8.3 Fuel resistance

When determined in accordance with ISO 1817, after immersion in Liquid B for $(48 \frac{+2}{0})$ h at standard laboratory temperature as specified in ISO 23529, the changes in the values of the properties of the flexible thermoplastics material used in the construction from the values for the un-immersed material shall not exceed those given in [Table 8](#).

Table 8 — Fuel resistance

| Property | Limit |
|--|-----------|
| Change in tensile strength, % of original value max. | -30 |
| Change in elongation at break, % of original value max. | -30 |
| Change in volume, % | -5 to +25 |

8.4 Oil resistance

When determined in accordance with ISO 1817 after immersion in IRM 903 oil for $(72 \frac{0}{-2})$ h at $70 \text{ °C} \pm 1 \text{ °C}$, the changes in the values of the properties of the flexible thermoplastics material used in the construction from the values for the un-immersed material shall not exceed those given in [Table 9](#).

Table 9 — Oil resistance

| Property | Limit |
|--|-----------|
| Change in tensile strength, % of original value max. | -40 |
| Change in elongation at break, % of original value max. | -40 |
| Change in volume, % | -5 to +25 |

8.5 Resistance to accelerated ageing

After ageing as specified in ISO 188 for 3 d at a temperature of $100 \text{ °C} \pm 2 \text{ °C}$, the changes in the values of the properties of the flexible thermoplastics material used in the construction from the values for the un-aged material shall not exceed those given in [Table 10](#) when determined in accordance with ISO 527-3 and ISO 868.

Table 10 — Change in properties on ageing

| Property | Limit |
|--|-------|
| Change in tensile strength, % of original value max. | -20 |
| Change in elongation at break, % of original value max. | -50 |
| Change in hardness (degrees Shore A) max. | +10 |

9 Hose assemblies

9.1 Couplings and method of attachment

The dimensions of couplings shall be compatible with the dimensions of the hose.

The method of attachment of the couplings shall be such that the hose assembly complies with [9.2](#).

9.2 Test for security of coupling

Hose assemblies shall withstand, without leakage or movement of the coupling with respect to the hose, the test described in [Annex D](#).

Couplings shall withstand a pressure equal to the minimum burst pressure without leakage or distortion.

There shall be no visible slits or other damage to the hose lining.

9.3 Electrical bonding

There shall be electrical continuity throughout the hose assembly and it shall be electrically bonded (Grade M). The hose construction shall include at least two flexible metallic bonding wires (with or without a metallic helix) incorporated in the hose between the cover and the lining and shall be bonded to the metal couplings.

When tested in accordance with ISO 8031, the hose assembly shall show an electrical resistance, measured between couplings, of less than $10^2 \Omega$.

9.4 Electrical wall resistance

When tested in accordance with ISO 8031, the wall resistance of the hose shall show an electrical resistance of less than $10^8 \Omega$.

10 Frequency of testing

The minimum frequency of testing shall conform to the schedule given in [Annex A](#).

Type tests are those tests carried out in order to verify that the hose meets all requirements of this International Standard.

Routine tests are those tests carried out on each length of finished hose.

Production tests are those tests carried out per batch. See schedule given in [Annex B](#) for guidance only.

11 Type tests

Type testing is carried out in order to confirm that all the materials, construction, and test requirements of this International Standard have been met by the method of manufacture and hose design.

Type testing shall be repeated at a maximum of every five years or whenever a change in the method of manufacture or materials occurs.

Type testing shall be performed for all sizes, classes, and types except those of same size and construction.

12 Marking

12.1 Hoses

Each length of hose shall be legibly and durably marked, at intervals of not more than 2 m on the outer cover, with at least the following information:

- a) the manufacturer's name or identification, e.g. XXX;
- b) the number and year of publication of this International Standard (i.e. ISO 6808:2014);
- c) the hose type, e.g. 2;
- d) the hose size, e.g. 25;
- e) the maximum working pressure, in MPa and/or bar including units, e.g. 0,55 MPa (5,5 bar);
- f) the symbol for electrical conductivity, M;
- g) the quarter and year of manufacture e.g. 2Q-1X.

EXAMPLE XXX/ISO 6808:2014/Type 2/25/0,55 MPa (5,5 bar)/M/2Q-1X

12.2 Hose assemblies

Couplings shall be permanently marked with the following information:

- a) the name or identification of the assembler;
- b) the quarter and year of assembly.

Annex A (normative)

Test frequency

[Table A.1](#) gives the frequency of testing for type tests and routine tests. (See [Clauses 6](#) through [10](#) for descriptions of these tests.)

Table A.1 — Frequency of testing for type tests and routine tests

| Property | Type test | Routine test |
|--|-----------|--------------|
| Thermoplastics material test | | |
| Loss of mass on heating | X | N/A |
| Tensile strength at break test | X | N/A |
| Elongation at break test | X | N/A |
| Fuel resistance test | X | N/A |
| Oil resistance test | X | N/A |
| Resistance to accelerated aging test | X | N/A |
| Hose test | | |
| Visual examination (inside and outside) | X | X |
| Measurement of inside diameter | X | X |
| Proof test | X | X |
| Burst test at standard laboratory temperature | X | N/A |
| Burst test at 55 °C ± 2 °C | X | N/A |
| Change in length test (Type 2 only) | X | X |
| Suction resistance test | X | N/A |
| Reinforcement fracture test | X | N/A |
| Minimum bend test | X | N/A |
| Cold bend test | X | N/A |
| Coupling security test | X | N/A |
| Electrical bonding test | X | N/A |
| NOTE X = test carried out, N/A = not applicable. | | |

Annex B (informative)

Production tests

[Table B.1](#) gives the suggested frequency for production tests (see [Clause 10](#)), to be carried out per batch or per 10 batches as indicated in this table.

A batch is defined as 3 000 m of hose.

Table B.1 — Recommended test frequency

| Property | Production test | |
|--|-----------------|----------------|
| | Per batch | Per 10 batches |
| Thermoplastics material test | | |
| Loss of mass on heating | N/A | N/A |
| Tensile strength at break test | N/A | X |
| Elongation at break test | N/A | X |
| Fuel resistance test | N/A | X |
| Oil resistance test | N/A | X |
| Resistance to accelerated aging test | N/A | N/A |
| Hose test | | |
| Visual examination (inside and outside) | X | X |
| Measurement of inside diameter | X | X |
| Proof test | X | X |
| Burst test at standard laboratory temperature | X | X |
| Burst test at 55 °C ± 2 °C | N/A | X |
| Change in length test (Type 2 only) | X | X |
| Suction resistance test | N/A | X |
| Reinforcement fracture test | N/A | N/A |
| Minimum bend test | N/A | X |
| Cold bend test | N/A | X |
| Coupling security test | X | X |
| Electrical bonding test | N/A | X |
| NOTE X = test carried out, N/A = not applicable. | | |

Annex C (normative)

Reinforcement fracture test

C.1 Apparatus

Required for use as extension blocks (see [Figure C.1](#)) are lengths of hardwood or metal of rectangular section with one cross-sectional dimension of the appropriate value given in [Table 6](#).

C.2 Test pieces

The test pieces shall contain three complete turns of reinforcement. Each test piece shall be split open with a clean cut along its length. Three test pieces shall be tested.

Test pieces shall be prepared from hose as supplied or from hose which has been immersed in IRM 903 oil as defined in ISO 1817.

C.3 Conditioning

No test shall be carried out within 24 h of manufacture. Test pieces shall be conditioned at standard laboratory temperature as specified in ISO 23529 for at least 3 h, which can be part of the 24 h, before testing.

C.4 Procedure

Open up a test piece and place it on an extension block of the size appropriate to its nominal bore as given in [Table 6](#).

Leave in this condition for either 336 h or 4 mo, as appropriate (see [7.5.1](#)).

Reverse bend the test piece until the outside surfaces touch, as shown in [Figure C.1](#), and examine for cracking of the helix.

Repeat with the remaining test pieces.

C.5 Test report

The test report shall include the following information:

- a) all details necessary for complete identification of each test piece;
- b) whether the test piece was tested in the as-received condition or after immersion in IRM 903 oil;
- c) the test temperature;
- d) the test period;
- e) either the statement “no failure” or details of the position and mode of failure;
- f) the date of the test.

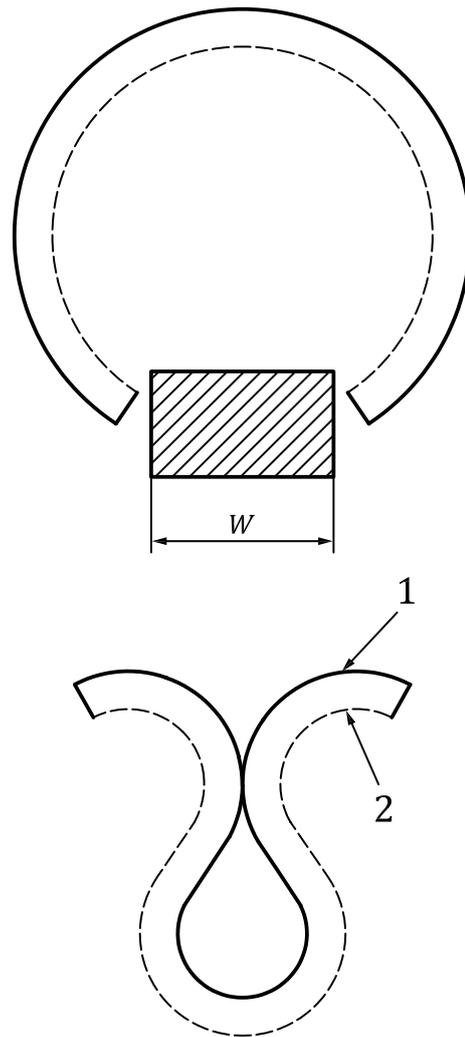

Key

- 1 outside surface
- 2 inside surface
- W block width (see [Table 6](#))

Figure C.1 — Diagrammatic representation of reinforcement fracture test

Annex D (normative)

Coupling security test

D.1 Test piece

Use an assembly of 1 m in length consisting of hose and couplings.

D.2 Procedure

Using water as the test medium, raise the test pressure to the proof pressure (i.e. 50 % of minimum burst pressure) and hold for 2 min.

Reduce the applied pressure to zero.

Increase the pressure to 50 % of the working pressure, hold for 2 min, and examine for leakage. Reduce the applied pressure to zero.

Increase the pressure to the minimum burst pressure, hold for 2 min, and examine for leakage.

Reduce the pressure to zero if the hose has not ruptured or the couplings have not been detached. Remove the couplings and examine the hose lining for slits and/or other damage.

D.3 Test report

The test report shall include at least the following:

- a) all details necessary for complete identification of the test assembly;
- b) either the statement “no damage” or details of any slits and/or other damage found;
- c) the date of the test.

Bibliography

- [1] ISO 8331, *Rubber and plastics hoses and hose assemblies — Guidelines for selection, storage, use and maintenance*
- [2] ISO/TR 17784, *Rubber and plastics hoses and hose assemblies — Guide for use by purchasers, assemblers, installers and operating personnel*

.....

