**Rubber or plastics hoses and hose
assemblies — Hydraulic-pressure
impulse test without flexing**

*Tuyaux et flexibles en caoutchouc ou en plastique — Essai
d'impulsions de pression hydraulique sans flexion*





COPYRIGHT PROTECTED DOCUMENT

© ISO 2017, Published in Switzerland

All rights reserved. Unless otherwise specified, no part of this publication may be reproduced or utilized otherwise in any form or by any means, electronic or mechanical, including photocopying, or posting on the internet or an intranet, without prior written permission. Permission can be requested from either ISO at the address below or ISO's member body in the country of the requester.

ISO copyright office
Ch. de Blandonnet 8 • CP 401
CH-1214 Vernier, Geneva, Switzerland
Tel. +41 22 749 01 11
Fax +41 22 749 09 47
copyright@iso.org
www.iso.org

Contents

| | Page |
|--|----------|
| Foreword | iv |
| 1 Scope | 1 |
| 2 Normative references | 1 |
| 3 Terms and definitions | 1 |
| 4 Apparatus | 1 |
| 5 Test fluid | 2 |
| 6 Test temperature | 2 |
| 7 Test pieces | 2 |
| 8 Procedure | 3 |
| 9 Expression of results | 4 |
| 10 Test report | 4 |
| Annex A (informative) Procedure for the optional cool down leakage test | 7 |
| Bibliography | 8 |

Foreword

ISO (the International Organization for Standardization) is a worldwide federation of national standards bodies (ISO member bodies). The work of preparing International Standards is normally carried out through ISO technical committees. Each member body interested in a subject for which a technical committee has been established has the right to be represented on that committee. International organizations, governmental and non-governmental, in liaison with ISO, also take part in the work. ISO collaborates closely with the International Electrotechnical Commission (IEC) on all matters of electrotechnical standardization.

The procedures used to develop this document and those intended for its further maintenance are described in the ISO/IEC Directives, Part 1. In particular the different approval criteria needed for the different types of ISO documents should be noted. This document was drafted in accordance with the editorial rules of the ISO/IEC Directives, Part 2 (see www.iso.org/directives).

Attention is drawn to the possibility that some of the elements of this document may be the subject of patent rights. ISO shall not be held responsible for identifying any or all such patent rights. Details of any patent rights identified during the development of the document will be in the Introduction and/or on the ISO list of patent declarations received (see www.iso.org/patents).

Any trade name used in this document is information given for the convenience of users and does not constitute an endorsement.

For an explanation on the meaning of ISO specific terms and expressions related to conformity assessment, as well as information about ISO's adherence to the World Trade Organization (WTO) principles in the Technical Barriers to Trade (TBT) see the following URL: www.iso.org/iso/foreword.html

This document was prepared by Technical Committee ISO/TC 45, *Rubber and rubber products*, Subcommittee SC 1, *Rubber and plastics hoses and hose assemblies*.

This fourth edition cancels and replaces the third edition (ISO 6803:2008), which has been technically revised to include cool down testing as specified in [4.1](#) and [8.2](#).

Rubber or plastics hoses and hose assemblies — Hydraulic-pressure impulse test without flexing

1 Scope

This document describes hose impulse testing, without flexing, of rubber or plastics hydraulic hose assemblies at both high and low impulse pressures. The high-pressure testing is carried out at pressures greater than 3 MPa and the low-pressure testing at pressures from 1,5 MPa to 3 MPa. The test procedure is applicable to hydraulic hose assemblies that are subject to pulsating pressures in service which are included in the product requirements.

NOTE Impulse test procedures with flexing can be found in ISO 6802.

2 Normative references

The following documents are referred to in the text in such a way that some or all of their content constitutes requirements of this document. For dated references, only the edition cited applies. For undated references, the latest edition of the referenced document (including any amendments) applies.

ISO 3448, *Industrial liquid lubricants — ISO viscosity classification*

ISO 8330, *Rubber and plastics hoses and hose assemblies — Vocabulary*

ISO/TR 11340, *Rubber and rubber products — Hydraulic hose assemblies — External leakage classification for hydraulic systems*

3 Terms and definitions

For the purposes of this document, the terms and definitions given in ISO 8330 apply.

ISO and IEC maintain terminological databases for use in standardization at the following addresses:

- IEC Electropedia: available at <http://www.electropedia.org/>
- ISO Online browsing platform: available at <http://www.iso.org/obp>

4 Apparatus

4.1 Pressure-application apparatus, capable of applying an internal pulsating pressure to the test piece at a rate specified in 8.2 using a hydraulic fluid circulating through the test hose, while the fluid is maintained at the required test temperature. Each pressure cycle shall be within the tolerances shown in Figure 2 (for high-pressure testing) or Figure 3 (for low-pressure testing). The nominal rate of pressure rise for high-pressure testing is given by Formula (1) in Figure 2. The rate of pressure rise for low-pressure testing shall be such that the pulse remains within the wave form envelope (see Figure 3).

4.2 Graphical recorder, digital-storage facility or oscilloscope, capable of measuring the pressure cycle to ensure that the wave form is within the envelope shown in Figure 2 or Figure 3. The recorder shall have a natural frequency of more than 250 Hz and shall be critically damped to give a response which is flat to within 5 % at up to 0,6 times the natural frequency.

5 Test fluid

Select a test fluid preferably with a kinematic viscosity from 32 mm²/s to 100 mm²/s at 40 °C (i.e. from grade ISO VG 32 to ISO VG 100 as specified in ISO 3448), and circulate it at a rate sufficient to maintain a uniform fluid temperature within the test pieces. Other fluids may be used as agreed upon between the customer and the manufacturer.

6 Test temperature

The test temperature is normally specified in the referring hose standard. When the test temperature is not defined in the hose standard, the following temperatures are the preferred temperatures:

85 °C, 100 °C, 120 °C, 125 °C, 135 °C, 150 °C

The test fluid shall be circulated through the test pieces at the specified or chosen temperature with a tolerance of ± 3 °C. Cooling or heating of the test chamber shall not be permitted, except when referring standards require testing with synthetic-base fluids at a temperature higher than 150 °C. When such higher temperatures are required, the test fluid need not be circulated, provided both the fluid and the test pieces are externally heated in the test chamber at the specified temperature with a tolerance of ± 5 °C.

7 Test pieces

7.1 Test pieces shall be complete hose assemblies with suitable end fittings attached. Unless otherwise specified, test four unaged hose assemblies with end fittings which have been attached for not more than 30 days. Where the referring standard requires, also test aged hose assemblies.

7.2 Calculate the necessary free length of the hose in the test piece as shown in [Figure 1](#).

For values of d less than 25,4 mm, use $d = 25,4$ mm for the $+2d$ term in the expression for the hose free length, so that the hose between the fitting shell and the start of the bend radius is straight.

The actual free hose length shall agree with the calculated free hose length to within ${}^+1_0$ % or ${}^+8_0$ mm, whichever is greater.

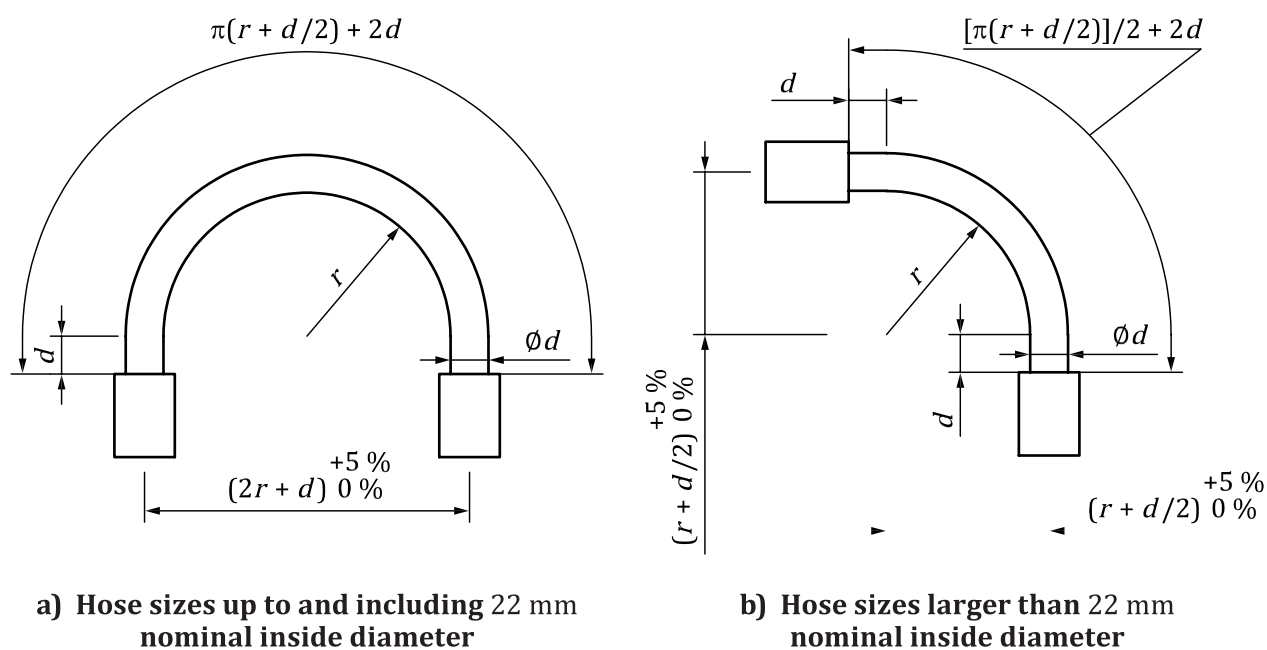
**Key**

- r minimum bend radius
 d hose outside diameter

Figure 1 — Test pieces for pressure impulse test**8 Procedure**

8.1 Connect the test pieces to the apparatus. The test pieces shall be installed in accordance with [Figure 1](#), i.e. test pieces of hose of nominal inside diameter up to and including 22 mm shall be bent through 180° and hoses of nominal inside diameter larger than 22 mm shall be bent through 90°.

8.2 Bring the test fluid to the test temperature and then apply a pulsating pressure internally to the hose assemblies at a uniform rate between 0,5 Hz and 1,3 Hz for the high-pressure test and between 0,2 Hz and 1,0 Hz for the low-pressure test. Record the pulse rate used. The pressure cycle shall fall within the shaded area of either [Figure 2](#) or [Figure 3](#), depending upon the test pressure. Continue the test for the specified number of cycles or until an assembly fails. If a test is stopped before completion of the minimum number of cycles and then restarted, leakage may occur at the hose/fitting junction upon restarting the test and until the test temperature is reached. Leakage less than class 4 as defined in ISO/TR 11340 does not constitute a failure of the hose assembly. Any leakage shall be reported in accordance with the classification in ISO/TR 11340.

Determine the duration required for the impulse test, in total number of cycles, from the referring standard. Where agreed samples are required, refer to the relevant hose or hose assembly standard.

It is recommended that the test fluid be changed frequently to prevent breakdown.

If the optional cool down leakage test for the impulse test is required in the individual product standard, then carry out the procedure as given in [Annex A](#).

This is a destructive test. Assemblies which have been subjected to this test, should therefore be discarded.

9 Expression of results

Record the number of cycles to failure or, if failure did not occur, the number of cycles completed.

NOTE The test results obtained are only valid for the combination of hose, fitting type and fitting design that was actually tested.

10 Test report

The test report shall include the following information:

- a) reference to this document, i.e. ISO 6803:2017;
- b) full description of the hose or hose assembly tested, including the fitting identification and attachment details, such as skive length and crimp diameter;
- c) test temperature;
- d) test pressure;
- e) test fluid;
- f) rate of pressure rise;
- g) pulse cycle rate;
- h) whether the test pieces were bent through 90° or through 180°;
- i) number of cycles to failure, or the number of cycles completed, for each test piece;
- j) position and mode of failure of each test piece, or the condition of each test piece on completion of the test;
- k) date of the test.

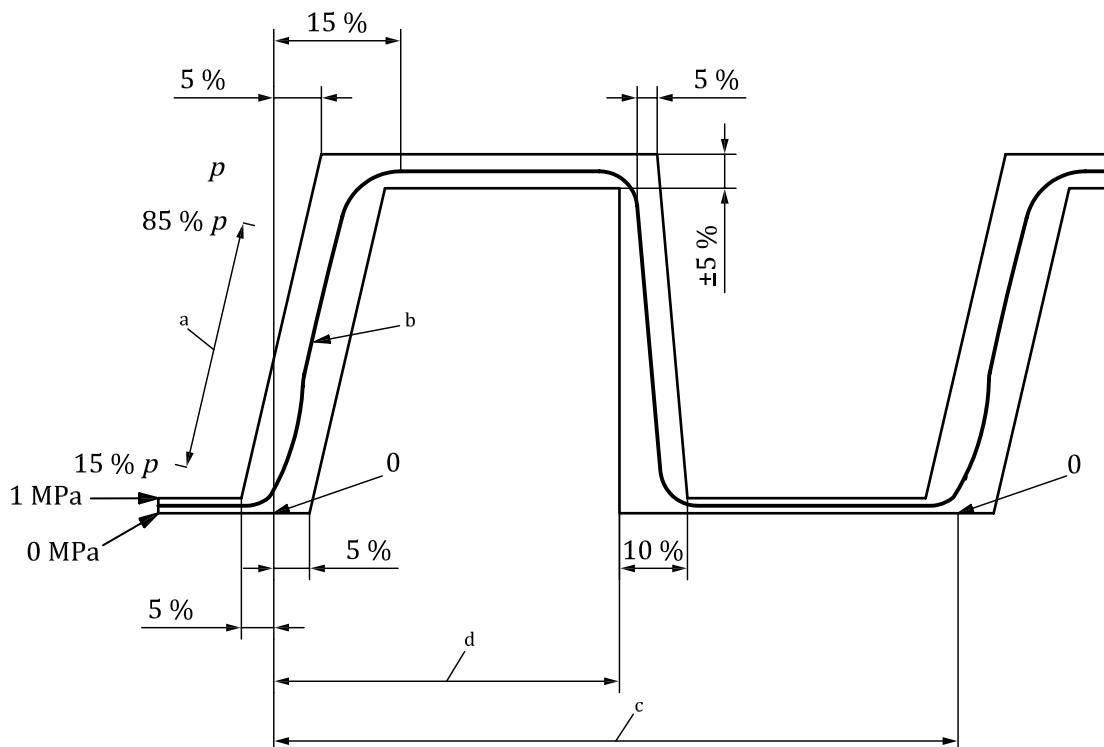

Key

- p test pressure
- a Rate of rise to be determined between these points.
- b Secant pressure rise.
- c One pulse cycle.
- d 45 % to 55 % of the cycle.

The secant pressure rise is the straight line drawn through two points on the pressure rise curve, one point at 15 % of the test pressure and the other at 85 % of the test pressure.

Point 0 is the intersection of the secant pressure rise with 0 pressure.

The rate of pressure rise is the slope of the secant pressure rise, expressed in MPa/s. The nominal rate of pressure rise shall be equal to that given by Formula (1):

$$R = f(10p - k) \quad (1)$$

where

- R is the rate of pressure rise, in MPa/s;
- f is the frequency, in Hz;
- p is the nominal test pressure, in MPa;
- $k = 5$ MPa.

The actual rate of pressure rise shall be determined as shown in the figure and shall be within a tolerance of $\pm 10\%$ of the calculated nominal value.

Figure 2 — Pressure pulse wave form envelope for high-pressure test

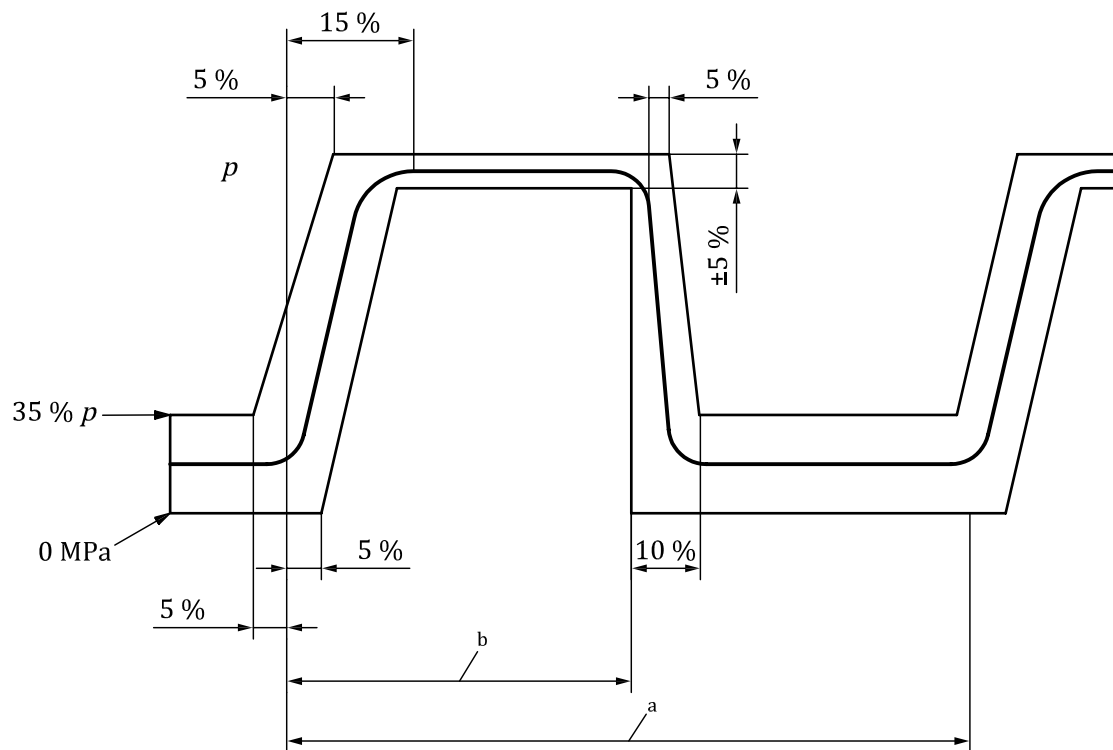

Key

- p test pressure
- a One pulse cycle.
- b 45 % to 55 % of the cycle.

The pressure rise shall be contained within the wave form envelope shown in the figure.

Figure 3 — Pressure pulse wave form envelope for low-pressure test

Annex A (informative)

Procedure for the optional cool down leakage test

If an optional cool down leakage test is required in the individual product standard then carry out the following test procedure in addition to the procedure given in [Clause 8](#).

The pressurization shall be stopped and the impulse test unit shall be allowed to cool down the temperature of the test fluid to $30\text{ °C} \pm 10\text{ °C}$ at $40\% \pm 10\%$ and $90\% \pm 10\%$ of the required number of impulse cycles.

Accelerated cool down procedures, i.e. fans, heat exchangers, etc., may be used to speed the cooling process.

Check test assemblies to ensure they are clean and dry. With oil heater turned off, resume the test and observe and note leakage for 1 000 impulse cycles.

Bibliography

- [1] ISO 6802, *Rubber and plastics hoses and hose assemblies with wire reinforcements — Hydraulic impulse test with flexing*

