

INTERNATIONAL STANDARD

ISO 6780

Second edition
2003-12-01

Flat pallets for intercontinental materials handling — Principal dimensions and tolerances

*Palettes plates pour la manutention et le transport dans les échanges
intercontinentaux — Dimensions principales et tolérances*



Reference number
ISO 6780:2003(E)

© ISO 2003

PDF disclaimer

This PDF file may contain embedded typefaces. In accordance with Adobe's licensing policy, this file may be printed or viewed but shall not be edited unless the typefaces which are embedded are licensed to and installed on the computer performing the editing. In downloading this file, parties accept therein the responsibility of not infringing Adobe's licensing policy. The ISO Central Secretariat accepts no liability in this area.

Adobe is a trademark of Adobe Systems Incorporated.

Details of the software products used to create this PDF file can be found in the General Info relative to the file; the PDF-creation parameters were optimized for printing. Every care has been taken to ensure that the file is suitable for use by ISO member bodies. In the unlikely event that a problem relating to it is found, please inform the Central Secretariat at the address given below.

© ISO 2003

All rights reserved. Unless otherwise specified, no part of this publication may be reproduced or utilized in any form or by any means, electronic or mechanical, including photocopying and microfilm, without permission in writing from either ISO at the address below or ISO's member body in the country of the requester.

ISO copyright office
Case postale 56 • CH-1211 Geneva 20
Tel. + 41 22 749 01 11
Fax + 41 22 749 09 47
E-mail copyright@iso.org
Web www.iso.org

Published in Switzerland

Contents

Page

Foreword	iv
Introduction	v
1 Scope	1
2 Normative references	1
3 Terms and definitions	1
4 Dimensions	3
4.1 Plan dimensions and tolerances	3
4.2 Vertical entry clearances for lifting devices	3
4.3 Horizontal clearances for lifting devices	5
4.4 Dimensions of bottom deck chamfers	8
4.5 Dimensions of pallet deck projections	8
4.6 Bearing surface of bottom decks	8
4.7 Limits of diagonal distortion	8
4.8 Flatness	8
Annex A (informative) Regional use of intercontinental pallet sizes	9
Annex B (normative) Horizontal clearances for pallet trucks and fork-lift trucks	10
Bibliography	13

Foreword

ISO (the International Organization for Standardization) is a worldwide federation of national standards bodies (ISO member bodies). The work of preparing International Standards is normally carried out through ISO technical committees. Each member body interested in a subject for which a technical committee has been established has the right to be represented on that committee. International organizations, governmental and non-governmental, in liaison with ISO, also take part in the work. ISO collaborates closely with the International Electrotechnical Commission (IEC) on all matters of electrotechnical standardization.

International Standards are drafted in accordance with the rules given in the ISO/IEC Directives, Part 2.

The main task of technical committees is to prepare International Standards. Draft International Standards adopted by the technical committees are circulated to the member bodies for voting. Publication as an International Standard requires approval by at least 75 % of the member bodies casting a vote.

Attention is drawn to the possibility that some of the elements of this document may be the subject of patent rights. ISO shall not be held responsible for identifying any or all such patent rights.

ISO 6780 was prepared by Technical Committee ISO/TC 51, *Pallets for unit load method of materials handling*.

This second edition cancels and replaces the first edition (ISO 6780:1988), which has been technically revised, and incorporates ISO 6780:1988/Amd. 1:1994.

Introduction

The purpose of this International Standard is to promote distribution efficiency through the use of a limited number of internationally recognized and approved pallet sizes that most countries can adopt. Promotion of these sizes will also help to discourage long-term regional differences within and between international and intercontinental trading nations.

This International Standard is intended to include compatibility between ISO-approved pallet sizes, unit load sizes, materials-handling equipment and transport containers and vehicles. It also provides a presentation of pallet features and includes Asia-Pacific preferred pallet sizes that had been omitted from previous editions.

Although every effort has been made to coordinate overall pallet dimensions specified in this International Standard with the unit load sizes defined in ISO 3676, it is recognized that these pallet sizes are unlikely to cover all requirements because of substantial differences in size, shape and density of products, variations in handling devices, as well as regional habits and practices.

Flat pallets for intercontinental materials handling — Principal dimensions and tolerances

1 Scope

This International Standard specifies the principal dimensions and tolerances for new single-deck and double-deck, reversible and non-reversible flat pallets, of all entry types and made of any material, related to their transportation and handling by pallet trucks, fork-lift trucks and other appropriate equipment.

The requirements for features such as openings, clearances, chamfers and wings that are required for efficient handling are also included.

The applicability of this International Standard to reversible pallets can be affected by their use in field conditions.

2 Normative references

The following referenced documents are indispensable for the application of this document. For dated references, only the edition cited applies. For undated references, the latest edition of the referenced document (including any amendments) applies.

ISO 445:1996, *Pallets for materials handling — Vocabulary*

ISO 509, *Pallet trucks — Principal dimensions*

3 Terms and definitions

For the purposes of this document, the terms and definitions given in ISO 445 and ISO 509 and the following apply.

3.1

pallet size

nominal plan view dimensions of pallet length and pallet width

3.2

pallet length

L

deck dimension in the direction of stringers or stringerboards

NOTE 1 If these members are not present, the length is the longer deck dimension.

NOTE 2 Pallet length is expressed first, followed by pallet width.

3.3

pallet width

W

deck dimension at right angles to the length

3.4

pallet truck

industrial truck, equipped with two fork arms extending over the structure of the frame containing trail wheels (single or tandem) located near the fork arm tips, which is designed to lift the pallet only sufficiently to permit horizontal movement

NOTE The truck may be a hand pallet truck or electrically operated.

3.5

fork-lift truck

industrial truck, equipped with two fork arms not extending over the frame structure when handling pallets, attached through the carriage to the mast of the truck, which is designed to lift the load permitting stacking and racking as well as horizontal movement

3.6

automatic handling system

computer directed and controlled equipment for the storage and movement of material that does not require direct human operators

3.7

end

vertical face of the pallet which corresponds to the width

3.8

side

vertical face of the pallet which corresponds to the length

3.9

four-way pallet

pallet permitting the entry of the fork arms of fork-lift trucks, pallet trucks and pallet stackers from all four directions

NOTE Adapted from ISO 445:1996, definition 3.4.

3.10

two-way pallet

pallet permitting the entry of the fork arms of fork-lift trucks, pallet trucks and pallet stackers from two opposite directions only

NOTE Adapted from ISO 445:1996, definition 3.3.

3.11

partial four-way pallet

pallet permitting four-way entry of the fork arms of fork-lift trucks and two-way entry of the fork arms of pallet trucks and pallet stackers

NOTE Adapted from ISO 445:1996, definition 3.5.

3.12

through transit

pallet usage cycle which anticipates that the full range of mechanical handling equipment may be applied at some stage of the journey

3.13

pallet stacker

industrial truck, equipped with two fork arms extending over the structure of the frame containing trail wheels, permitting horizontal movement of the pallet and stacking of the pallet on the free entry side

4 Dimensions

4.1 Plan dimensions and tolerances

4.1.1 Rectangular plan dimensions

The rectangular plan dimensions of pallets conforming to this International Standard shall be as indicated in Table 1. Regional use of these pallet sizes is given in Annex A.

Table 1 — Rectangular plan dimension sizes

Metric mm	Imperial in
1 200 × 800	47,2 × 31,5
1 200 × 1 000	47,2 × 39,4
1 219 × 1 016	48 × 40
NOTE 1 The above plan dimensions describe pallet sizes only. They do not suggest or imply preferred pallet lengths or preferred pallet widths as defined in ISO 445.	
NOTE 2 With sawn timber, the dimensions stated should be associated with a specified moisture content. For plastics, dimensions should be measured at a temperature of 23 °C ± 2 °C.	

4.1.2 Square plan dimensions

The square plan dimensions of pallets conforming to this International Standard shall be as indicated in Table 2. Regional use of these pallet sizes is given in Annex A.

Table 2 — Square plan dimension sizes

Metric mm	Imperial in
1 067 × 1 067	42 × 42
1 100 × 1 100	43,3 × 43,3
1 140 × 1 140	44,9 × 44,9
NOTE The Notes given in Table 1 apply.	

4.1.3 Tolerances

Manufacturing tolerances on the plan dimensions given in 4.1.1 and 4.1.2 shall be $\begin{matrix} +3 \\ -6 \end{matrix}$ mm.

4.2 Vertical entry clearances for lifting devices

4.2.1 Pallet trucks

The vertical entry clearance H_1 under the top deck for the entry of fork arms of pallet trucks, as shown in Figure 1, shall not be less than those values listed in Table 3. The distance from the top of the opening to the bottom surface of the pallet, H_2 as shown in Figure 1, shall not exceed 156 mm.

The vertical clearance for some pallet designs are shown in Figure 1.

Table 3 — Minimum vertical entry clearance for pallets in use with pallet trucks

Pallet	Minimum vertical entry clearance mm
High profile	100
Standard profile	95
Low profile	89

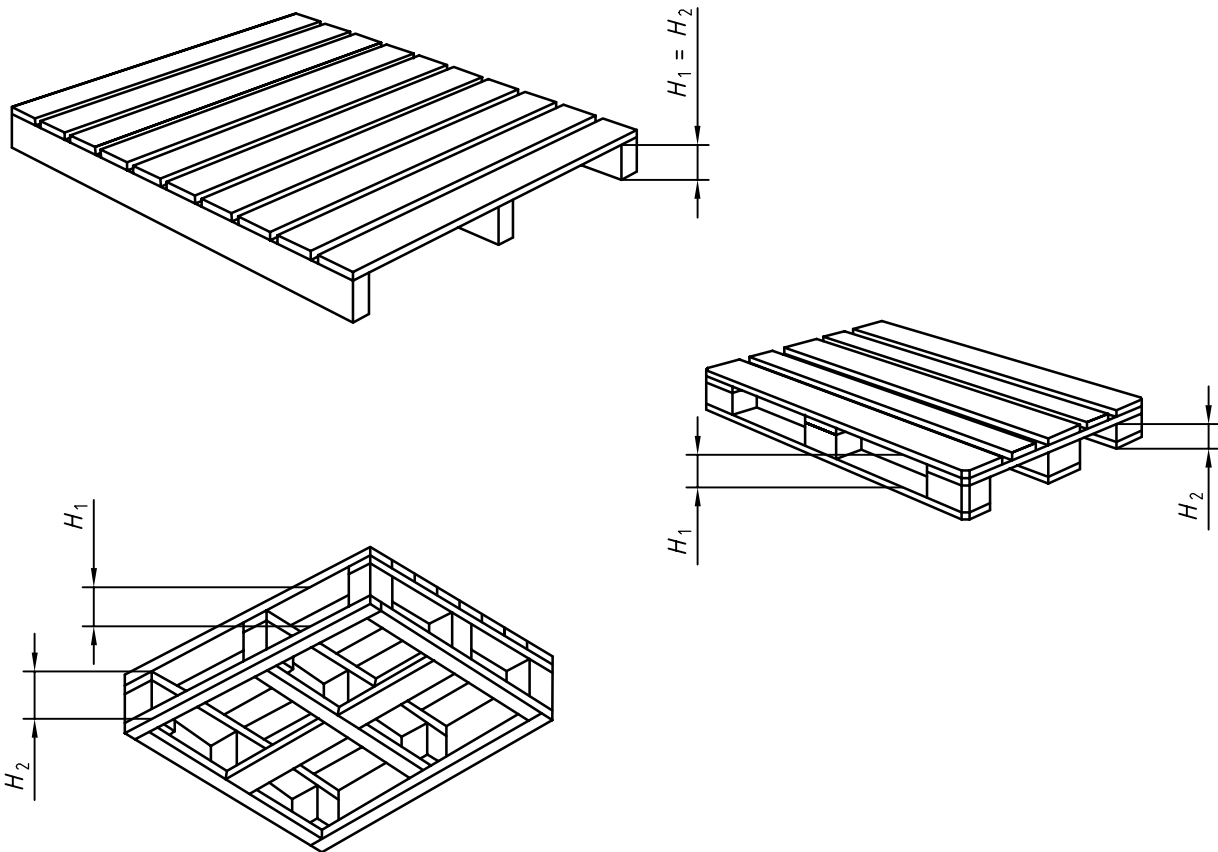

H_1 is the vertical entry clearance.

H_2 is the distance from the top of the opening to the bottom surface of the pallet.

Figure 1 — Vertical entry clearance for lifting devices for two-way and four-way entry pallets

4.2.2 Fork-lift trucks

The vertical clearance for the entry of fork arms of fork-lift trucks shall not be less than 50 mm.

The minimum clearance of 50 mm may not be sufficient in certain European countries where 55 mm is needed.

4.2.3 Other types of handling/lifting devices

For other types of handling/lifting devices, the dimensions given in 4.2.1 apply. The minimum clearance for pallets used in automatic handling systems is recommended as 100 mm.

4.3 Horizontal clearances for lifting devices

4.3.1 End and side entry

Horizontal clearances for the entry of pallet trucks into the ends of two-way and partial four-way pallets and into the ends and sides of four-way pallets shall conform to those dimensions specified in Table 4 and shown in Figure 2 and Annex B.

When the distance between fork arms is greater than 180 mm, as in ISO 509, L_1 and W_1 shall be at least 20 mm less than the distance between the fork arms.

Table 4 — Horizontal clearances for lifting devices

Dimensions in millimetres

Nominal dimension of pallet L or W	Entries and openings	
	L_1 max. and W_1 max.	L_2 min. and W_2 min.
800	160	580
$\geq 1\ 000$	160	710

4.3.2 Horizontal clearance of entries and openings for side entry into partial four-way pallets

Horizontal clearances for the entry of pallet trucks into the sides of partial four-way pallets shall conform to those dimensions specified in Table 5 and shown in Figure 3.

NOTE The dimension L_3 as illustrated in Figure 3 can be as great as 200 mm in partial four-way entry pallets designed to be handled by fork-lift trucks.

Table 5 — Horizontal clearance of entries and openings for side entry into partial four-way pallets

Dimensions in millimetres

Pallet length L	Entries and openings					
	L_5		L_4		L_3	
	min.	max.	min. ^a	max.	min.	max.
800 ^b	90	140	200	210	100	220
1 000	90	155	200	255	180	420
1 016	90	155	200	255	196	436
1 067	90	155	200	255	247	487
1 100	90	155	200	255	280	520
1 140	90	155	200	255	320	560
1 200	90	155	200	255	380	620
1 219	90	155	200	255	399	639

^a Pallets with these minimum dimensions cannot be handled by pallet trucks equipped with tandem trail wheels.

^b Pallets of this length cannot be handled by pallet trucks equipped with tandem trail wheels.

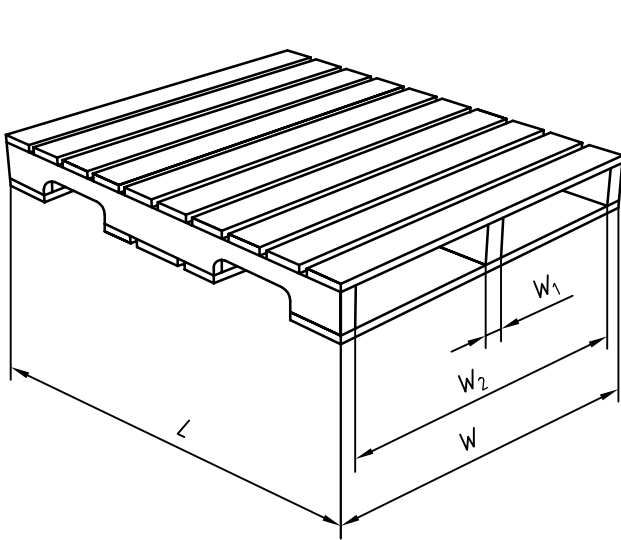

a) Entries: partial four-way pallet

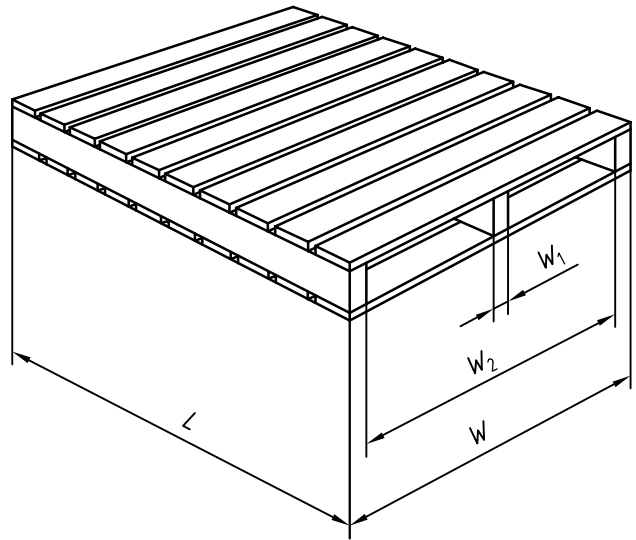

b) Entries: reversible two-way pallet

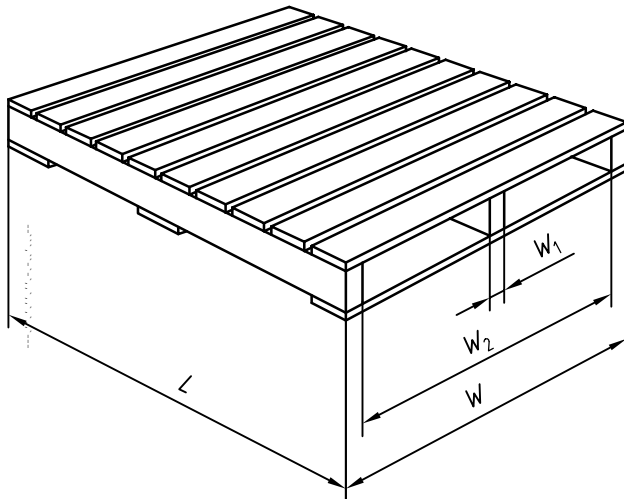

c) Entries: non-reversible two-way pallet

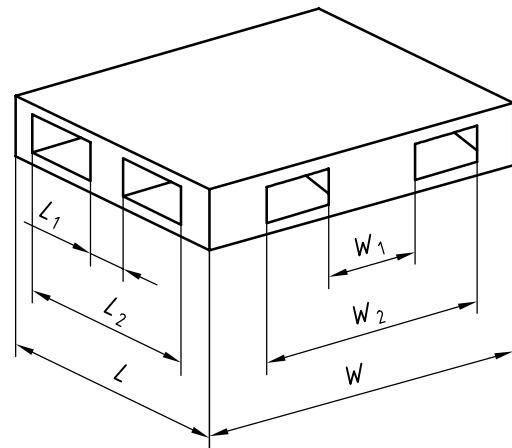

d) Entries: four-way pallet

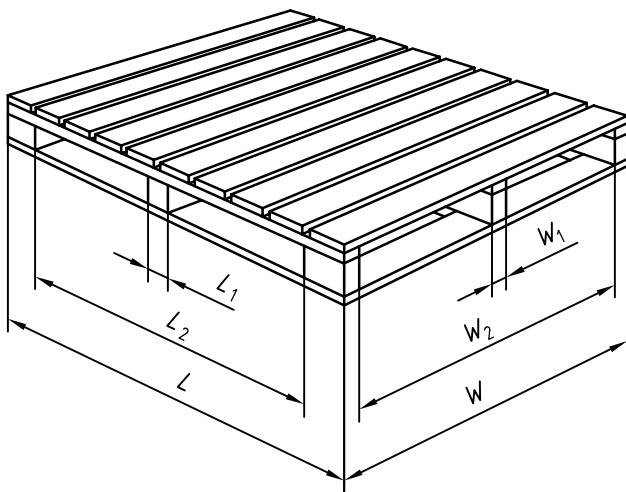

e) Entries: four-way pallet

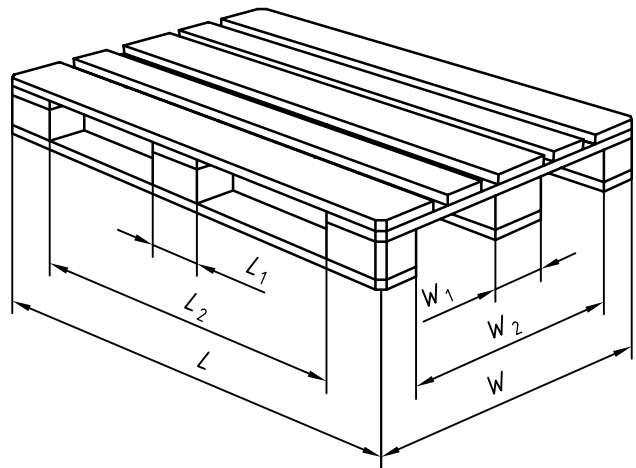

f) Entries: four-way pallet

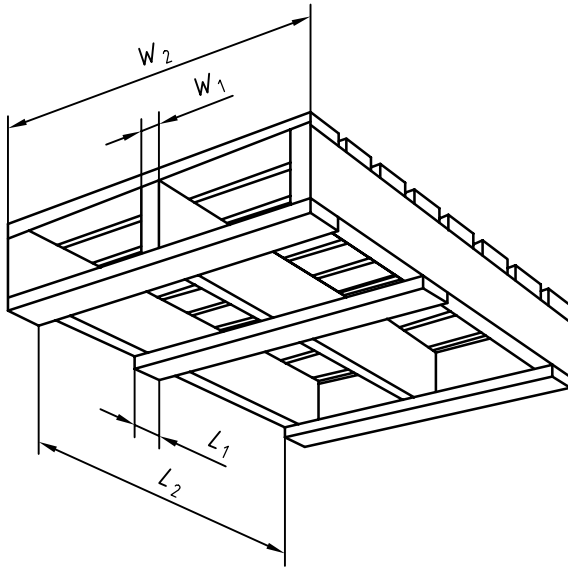

g) Openings: non-reversible two-way pallet

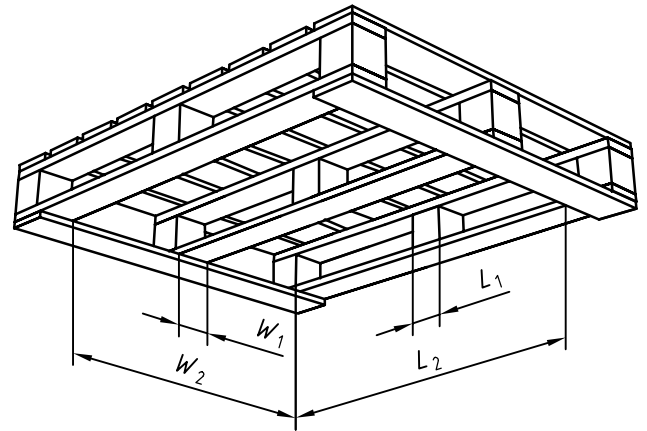

h) Openings: four-way pallet

Figure 2 — Horizontal clearance of side or end entries and bottom deck openings

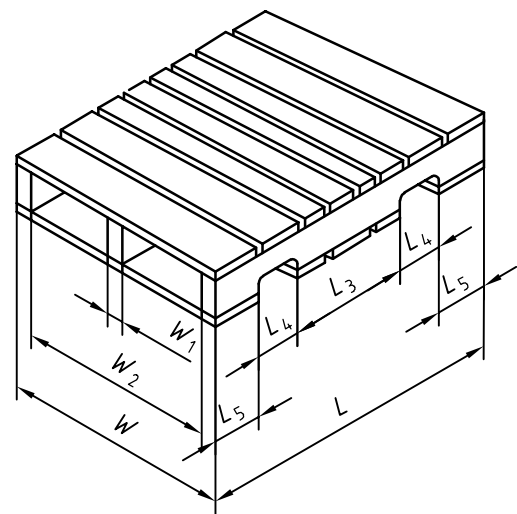
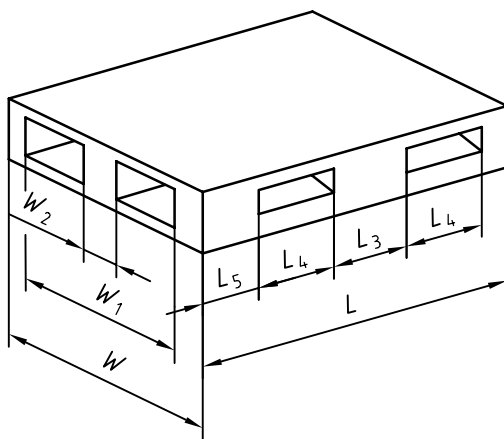

Figure 3 — Horizontal clearance of entries and openings for side entry into partial four-way entry pallets

4.4 Dimensions of bottom deck chamfers

Dimensions of bottom deck chamfers, where required for ease of handling with pallet trucks, shall be as follows:

- a) the chamfer face shall be $40^\circ \pm 5^\circ$ from the horizontal;
- b) the height of the vertical face of the chamfered member shall not exceed 16 mm;
- c) the maximum distance from the end of the chamfers to deck separating members shall be 65 mm.

Under certain conditions of handling that does not include pallet trucks, the thickness of the bottom deck may exceed 28 mm.

4.5 Dimensions of pallet deck projections

Projections of pallets up to 65 mm are known as lips; projections of 65 mm or longer are considered as wings.

4.6 Bearing surface of bottom decks

The minimum bearing surface of all pallets shall be 35 % of the nominal bottom deck plan dimension (pallet footprint).

4.7 Limits of diagonal distortion

The difference in length between the two diagonals shall not exceed 1 % of the original diagonal length at the time of manufacture.

4.8 Flatness

Vertical deviation from the target horizontal plane of the pallet deck shall not exceed 7 mm.

Intentional protrusions in the deck may exceed 7 mm.

Annex A (informative)

Regional use of intercontinental pallet sizes

It is recognised that there are pallet sizes other than those given in Table A.1 in use in current world trade. Although these sizes do not conform to the requirements of this International Standard, it is recommended that the provisions of 4.2 to 4.8 are taken into account where possible.

Table A.1 — Pallet sizes used in different regions

Europe		North America		Pacific rim	
Metric mm	Imperial in	Metric mm	Imperial in	Metric mm	Imperial in
1 200 × 800	47 ¹ / ₄ × 31 ¹ / ₂	1 219 × 1 016	48 × 40	1 100 × 1 100	43 ¹ / ₄ × 43 ¹ / ₄
1 200 × 1 000	47 ¹ / ₄ × 39 ³ / ₈	1 067 × 1 067	42 × 42		
1 140 × 1 140	44 ⁷ / ₈ × 44 ⁷ / ₈				

Annex B (normative)

Horizontal clearances for pallet trucks and fork-lift trucks

The horizontal clearances for pallet trucks and fork-lift trucks shall be as shown in Figures B.1, B.2 and B.3.

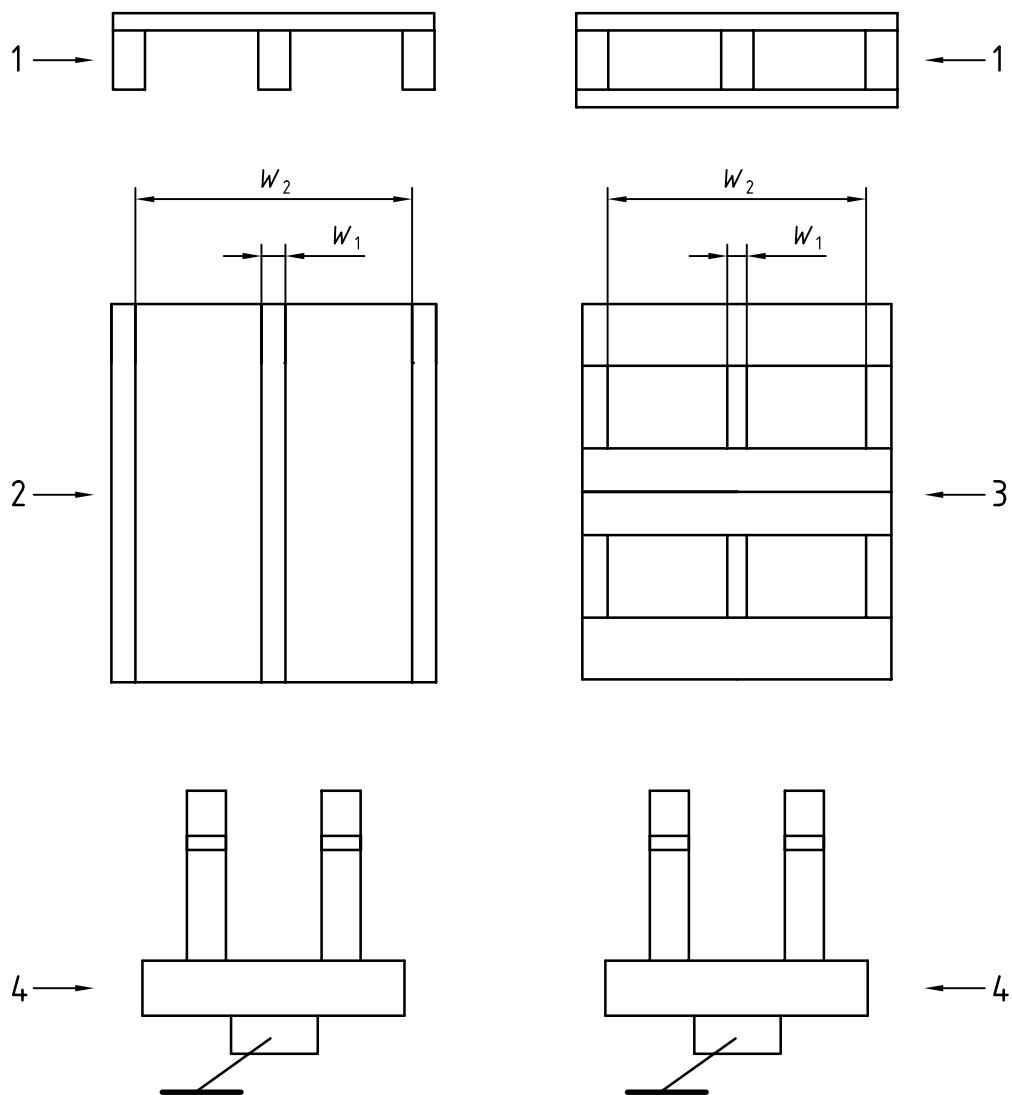

Key

- 1 end view
- 2 bottom deck
- 3 bottom deck view
- 4 fork arms of pallet trucks or fork-lift trucks

**Figure B.1 — Horizontal clearance for pallet trucks and fork-lift trucks —
Examples of two-way pallet designs**

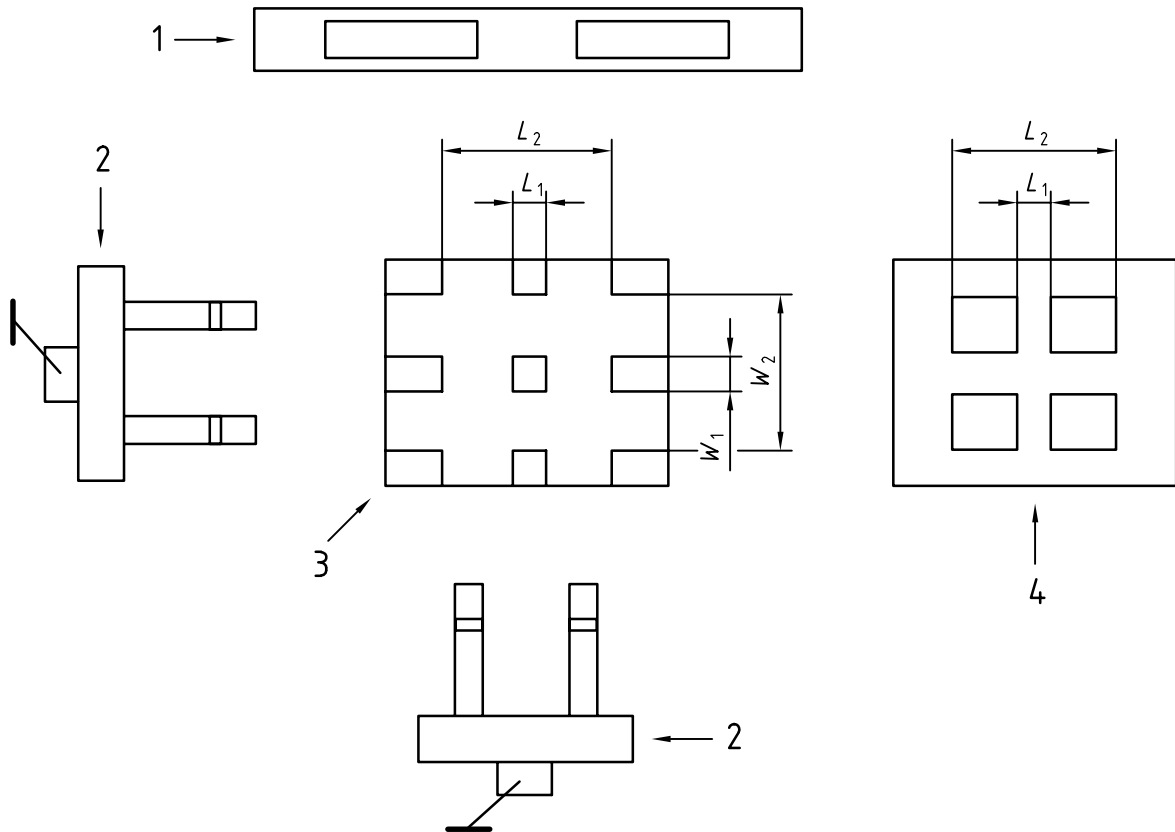

Key

- 1 end or side view
- 2 fork arm of pallet truck or fork-lift truck
- 3 bottom view without bottom deck
- 4 bottom deck view

NOTE If L_1 is more than 160 mm, the pallet is a partial four-way pallet to be handled by fork-lift trucks.

Figure B.2 — Horizontal clearance for pallet trucks and fork-lift trucks — Four-way pallet designs

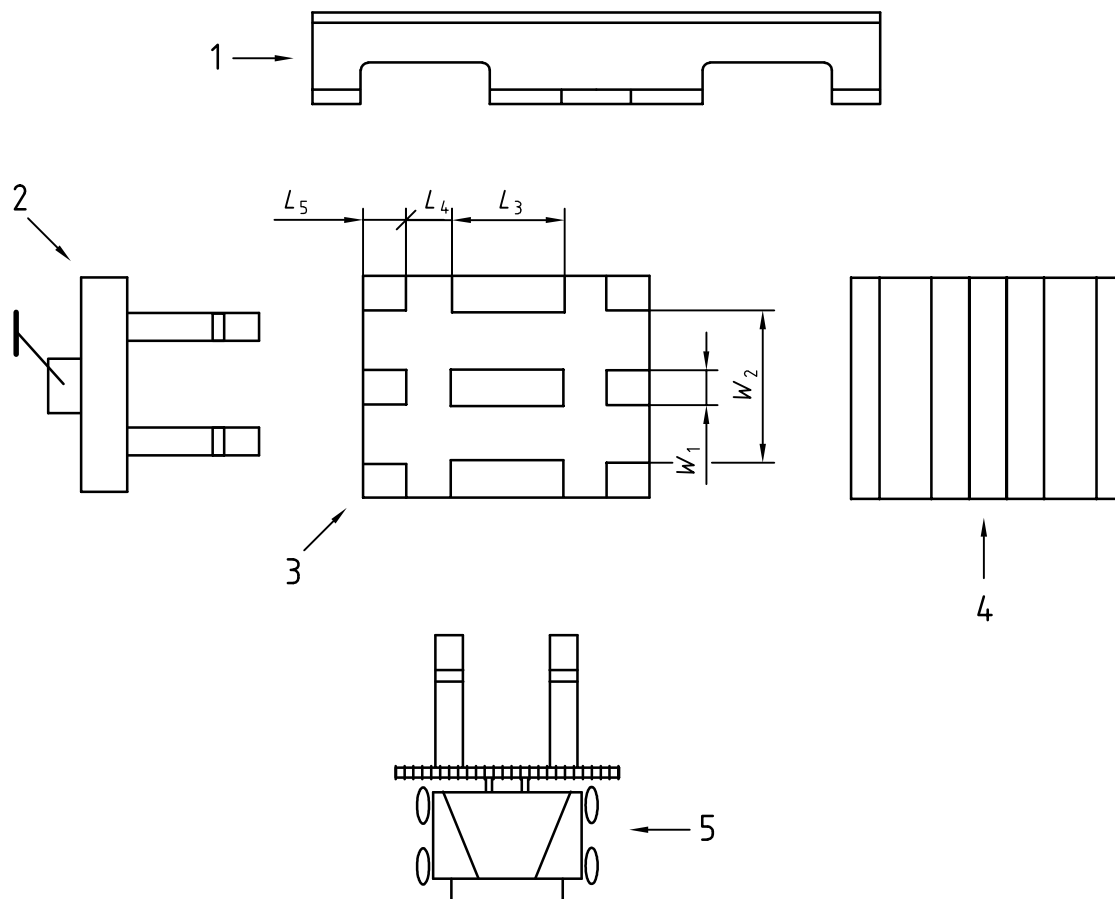

Key

- 1 bottom deck view
- 2 fork arms of pallet truck or fork-lift truck
- 3 bottom view without bottom deck
- 4 bottom view with bottom deck
- 5 fork arm of fork-lift truck

Figure B.3 — Horizontal clearance for pallet trucks or fork-lift trucks — Partial four-way pallet

Bibliography

- [1] ISO 668, *Series 1 freight containers — Classification, dimensions and ratings*
- [2] ISO 3394, *Dimensions of rigid rectangular packages — Transport packages*
- [3] ISO 3676, *Packaging — Unit load sizes — Dimensions*
- [4] ISO 4117, *Air and air/land cargo pallets — Specification and testing*

ICS 55.180.20

Price based on 13 pages