**Cycles — Lighting and retro-
reflective devices —**

Part 4:
**Lighting systems powered by the
cycle's movement**

*Cycles — Dispositifs d'éclairage et dispositifs rétro réfléchissants —
Partie 4: Systèmes d'éclairage alimentés par dynamo*



COPYRIGHT PROTECTED DOCUMENT

© ISO 2015, Published in Switzerland

All rights reserved. Unless otherwise specified, no part of this publication may be reproduced or utilized otherwise in any form or by any means, electronic or mechanical, including photocopying, or posting on the internet or an intranet, without prior written permission. Permission can be requested from either ISO at the address below or ISO's member body in the country of the requester.

ISO copyright office
Ch. de Blandonnet 8 • CP 401
CH-1214 Vernier, Geneva, Switzerland
Tel. +41 22 749 01 11
Fax +41 22 749 09 47
copyright@iso.org
www.iso.org

Contents

Page

Foreword	iv
1 Scope	1
2 Normative references	1
3 Terms and definitions	1
4 Lamps and interchangeable generators	2
4.1 General	2
4.2 Requirements	2
4.2.1 Dynamo-operated front lights	2
4.2.2 Dynamo-operated rear lights	2
4.2.3 Dynamos	3
4.3 Test Methods	4
4.3.1 Dynamo-operated front lights	4
4.3.2 Dynamo-operated rear lights	4
4.3.3 Dynamos	4
5 Lamps and dedicated generators	5
5.1 General	5
5.2 Requirements	5
5.2.1 Principle of lighting system	5
5.2.2 Speed ranges	5
5.3 Safety requirements	5
5.3.1 Environmental behaviour	5
5.3.2 Test method	6
6 Common requirements and test methods for lighting systems and the loading	6
6.1 Requirements	6
6.1.1 Corrosion resistance	6
6.1.2 Water resistance	6
6.1.3 Loading requirements	6
6.2 Test methods	6
6.2.1 Corrosion testing	6
6.2.2 Water resistance	6
6.2.3 Test of electronic load	6
7 Instructions	7
8 Marking	7
8.1 Requirement	7
8.2 Durability test	7
8.2.1 Requirement	7
8.2.2 Test method	7
Annex A (informative) Electronic load for power-measurement of 6 V/1,5 W LED dynamos	8
Annex B (informative) Efficiency calculation	10
Annex C (informative) Verification of the electronic load	11
Bibliography	13

Foreword

ISO (the International Organization for Standardization) is a worldwide federation of national standards bodies (ISO member bodies). The work of preparing International Standards is normally carried out through ISO technical committees. Each member body interested in a subject for which a technical committee has been established has the right to be represented on that committee. International organizations, governmental and non-governmental, in liaison with ISO, also take part in the work. ISO collaborates closely with the International Electrotechnical Commission (IEC) on all matters of electrotechnical standardization.

The procedures used to develop this document and those intended for its further maintenance are described in the ISO/IEC Directives, Part 1. In particular the different approval criteria needed for the different types of ISO documents should be noted. This document was drafted in accordance with the editorial rules of the ISO/IEC Directives, Part 2 (see www.iso.org/directives).

Attention is drawn to the possibility that some of the elements of this document may be the subject of patent rights. ISO shall not be held responsible for identifying any or all such patent rights. Details of any patent rights identified during the development of the document will be in the Introduction and/or on the ISO list of patent declarations received (see www.iso.org/patents).

Any trade name used in this document is information given for the convenience of users and does not constitute an endorsement.

For an explanation on the meaning of ISO specific terms and expressions related to conformity assessment, as well as information about ISO's adherence to the WTO principles in the Technical Barriers to Trade (TBT), see the following URL: [Foreword — Supplementary information](#).

The committee responsible for this document is ISO/TC 149, *Cycles, SC 1, Cycles and major sub-assemblies*.

ISO 6742 consists of the following parts, under the general title *Cycles — Lighting and retro-reflective devices*:

- *Part 1: Lighting and light signalling devices*
- *Part 2: Retro reflective devices*
- *Part 3: Installation and use of lighting and retro-reflective devices*
- *Part 4: Lighting systems powered by the cycle's movement*
- *Part 5: Lighting systems not powered by the cycle's movement*

Cycles — Lighting and retro-reflective devices —

Part 4:

Lighting systems powered by the cycle's movement

1 Scope

This part of ISO 6742 is applicable to lighting systems used on cycles intended to be used on public roads and, especially, bicycles complying with ISO 4210 and ISO 8098.

This part of ISO 6742 specifies requirements and test methods for the performance of lighting systems powered by the cycle's movement. It applies to light devices complying with ISO 6742-1. Lighting systems include lighting devices and power supplied by cycle's movement such as generator.

2 Normative references

The following documents, in whole or in part, are normatively referenced in this document and are indispensable for its application. For dated references, only the edition cited applies. For undated references, the latest edition of the referenced document (including any amendments) applies.

ISO 6742-1:2015, *Cycles — Lighting and retro-reflective devices — Part 1: Lighting and light signalling devices*

ISO 6742-3:2015, *Cycles — Lighting and retro-reflective devices — Part 3: Installation and use of lighting and retro-reflective devices*

ISO 9227, *Corrosion tests in artificial atmospheres — Salt spray tests*

IEC 60529, *Degrees of protection provided by enclosures (IP Code)*

3 Terms and definitions

For the purposes of this document, the terms and definitions given in ISO 6742-1 and the following apply.

3.1

frictional drive generator

generator for which the rotor or stator is linked to a pulley which press against the driving wheel over a swivel bearing through force

3.2

positive drive generator

generators which are not concerned by the definition of *frictional drive generator* (3.1)

3.3

integrated lamp and power source

system including power source and at least one type of light designed to be used together, closed system

Note 1 to entry: Power generator characteristics are depending of vehicle movement.

Note 2 to entry: Light output performances are depending of the speed of the vehicle, or the time during which bicycle has been stopped.

4 Lamps and interchangeable generators

4.1 General

The complete system shall be designed as open system which requires compatibility between lamps and generators.

4.2 Requirements

4.2.1 Dynamo-operated front lights

Dynamo-operated front lights (lamps emitting light to the front) shall correspond with the requirements of ISO 6742-1:2015, 4.2 (Front position lamp), 4.5 (Low beam) and 4.6 (High beam).

Voltage limiting resources shall only become effective above the test voltage. Here, the value of the DC voltage, U , corresponds with the root mean square of the AC voltage, U_{eff} .

Furthermore:

- the nominal voltage of the light source shall be equal to the system voltage or the light source shall be powered via an appropriate electronic ballast;
- the lighting effect shall be deployed at $3 U_{eff}$ at the latest;
- the lighting evaluation shall be performed at test voltage;
- the power consumption shall be ≤ 110 % of the nominal value;
- the power consumption shall be 2,4 W or less at the test voltage;
- electronic ballasts in these units shall have the corresponding electrical rating.

Head lamps with integrated capacitor to power the light while halting shall be built so that the load of the entire equipment on the supply system is not substantially higher than that intended for this equipment according to ISO 6742-1:2015, 4.8. The entire equipment shall fulfil the necessary requirements at test voltage, where, based on a discharged capacitor, a charging time of 120 s using test voltage is permissible and the reduction of the dynamo voltage through the charging of the capacitor shall correspond with the following conditions:

- a) not exceeding 60 % after 15 s;
- b) not exceeding 37 % after 30 s;
- c) not exceeding 15 % after 60 s;
- d) not exceeding 5 % after 90 s;
- e) not exceeding 1,5 % after 120 s.

Any stand light shall emit visible light for at least 240 s.

4.2.2 Dynamo-operated rear lights

Dynamo-operated rear lights (lamps emitting light to the rear) shall correspond with the requirements of ISO 6742-1:2015, 4.3 (Rear lamp), 4.4 (Stop lamp) and 4.8 (Stand light). And the power consumption shall be 0,6 W or less at the test voltage.

Rear lamps with integrated stand lights shall be built so that the load of the entire equipment on the supply system is not substantially higher than that intended for this equipment. The entire equipment shall fulfil the necessary requirements at test voltage, where, based on a discharged capacitor, a charging

time of 120 s using test voltage is permissible and the reduction of the dynamo voltage through the charging of the capacitor shall correspond with the following conditions:

- a) not exceeding 60 % after 15 s;
- b) not exceeding 37 % after 30 s;
- c) not exceeding 15 % after 60 s;
- d) not exceeding 5 % after 90 s;
- e) not exceeding 1,5 % after 120 s.

Any stand light shall emit visible light for at least 240 s.

4.2.3 Dynamos

4.2.3.1 General characteristics of generators

For measurements according to 4.2.3, voltage and power of dynamos shall meet the values of Table 1.

For generators, for which the outputs characteristics are depending on diameter of the wheel, the minimum values given in Table 1 of the voltage and the efficiency refer to the largest outside diameter of the wheel as provided by the manufacturer. The measurement of the maximum values in Table 1 of the voltage refers to the smallest outside diameter of the wheel as stated by the manufacturer.

Table 1 — Characteristics of generators

Type of generator	System	Speed km/h				Efficiency η %
		15	≥ 5	≥ 10	≥ 15 ≤ 30	
Frictional drive	6 V/3 W and 6 V/2,4 W and 6 V/1,5 W with fixed resistor	$\geq 5,7$ V $\leq 7,5$ V	≥ 3 V $\leq 7,5$ V		$\geq 5,7$ V $\leq 7,5$ V	≥ 30
	6 V/1,5 W with electric load	$\geq 1,35$ W $\leq 4,7$ W	$\geq 0,2$ W $\leq 4,7$ W		$\geq 1,35$ W $\leq 4,7$ W	≥ 30
Positive drive	6 V/3 W and 6 V/2,4 W and 6 V/1,5 W with fixed resistor	$\geq 5,7$ V $\leq 7,5$ V	≥ 3 V $\leq 7,5$ V		$\geq 5,7$ V $\leq 7,5$ V	≥ 30
	6 V/1,5 W with electric load	$\geq 1,35$ W $\leq 4,7$ W	$\geq 0,2$ W $\leq 4,7$ W		$\geq 1,35$ W $\leq 4,7$ W	≥ 30

4.2.3.2 Generator — Frictional dynamo

For dynamos which press against the driving wheel over a swivel bearing through spring force, the spring force, measured perpendicularly to the rotational axis of the dynamo, shall be 10 N inside of the total swivel area to loose contact with tyre. This value shall also be used for the measurement of the efficiency.

Should an AC voltage of 50 V_{eff} or a DC voltage of 75 V be exceeded for this unloaded dynamo within the specified speed range, additional measures shall be provided in order to meet this voltage limit.

4.2.3.3 Generator — Positive drive

For dynamos without gears and for the largest outside diameter of the wheel permissible for these dynamos and at a speed of 5 km/h, the frequency of the AC voltage shall be at least 6 Hz.

Should an AC voltage of 50 V_{eff} or a DC voltage of 75 V be exceeded for this unloaded dynamo within the specified speed range, additional measures shall be provided in order to meet this voltage limit.

4.3 Test Methods

4.3.1 Dynamo-operated front lights

Dynamo-operated front lights (lamps emitting light to the front) have to be tested corresponding with the test methods of ISO 6742-1:2015, 4.2 (Front position lamp), 4.5 (Low beam) and 4.6 (High beam). The test voltage shall be the rated voltage of substantially sinusoidal AC (frequency 50 Hz or 60 Hz) or DC.

Measure the voltage at the terminal of the dynamo.

4.3.2 Dynamo-operated rear lights

Dynamo-operated rear lights (lamps emitting light to the rear) have to be tested corresponding with the test methods of ISO 6742-1:2015, 4.3 (Rear lamp), 4.4 (Stop lamp) and 4.8 (Stand light). The test voltage shall be the rated voltage of substantially sinusoidal AC (frequency 50 Hz or 60 Hz) or DC.

Measure the voltage at the terminal of the dynamo.

4.3.3 Dynamos

4.3.3.1 General characteristics of generators

Measure the voltage and power at the terminal of the dynamo.

The efficiency can be measured according to [Annex B](#) and each parameter shall be defined by a manufacture of generators.

4.3.3.2 Frictional dynamos

6 V/3 W dynamos at a load of 12 Ω, 6 V/2,4 W dynamos at a load of 15 Ω and 6 V/1,5 W LED dynamos at an electronic load according [Annex A](#) shall then be applied or at a load of 24 Ω.

Before the measurement, the dynamo thus loaded shall be operated at an ambient temperature of (23 ± 5) °C without forced cooling for 20 min at a number of revolutions corresponding to a speed of 30 km/h After cooling of the dynamo to ambient temperature, the voltage characteristics as well as the efficiency shall be determined. Here, a driving wheel with a treadless surface shall be used.

The measurements shall be carried out with the following procedure:

- determine output voltage and efficiency after 5 min of continuous operation at a speed of 15 km/h;
- determine output voltage after reduction of speed to 5 km/h;
- determine output voltage after raising speed up to, but not exceeding 30 km/h.

4.3.3.3 Positive drive dynamos

6 V/3 W dynamos at a load of 12 Ω, 6 V/2,4 W dynamos at a load of 15 Ω and 6 V/1,5 W LED dynamos at an electronic load according to [Annex A](#) shall then be applied or at a load of 24 Ω.

Before the measurement, the dynamo thus loaded shall be operated at an ambient temperature of (23 ± 5) °C without forced cooling for 20 min at a number of revolutions corresponding with a speed of 30 km/h After cooling of the dynamo to ambient temperature the voltage characteristics as well as the efficiency shall be determined.

The measurements shall be carried out with the following procedure:

- determine output voltage and efficiency after 5 min of continuous operation at a speed of 15 km/h;
- determine output voltage after reduction of speed to 5 km/h;
- determine output voltage after raising speed up to, but not exceeding 30 km/h.

5 Lamps and dedicated generators

5.1 General

The complete system shall be designed as closed system which does not have compatibility between lamps and generators.

5.2 Requirements

5.2.1 Principle of lighting system

This system concerns front position lamps, rear lamps, stop lamps, direction indicators, low beam lamps and high beam lamps.

- a) Measure the voltage (V_{eff}) at output of the generator for the different speeds with the lighting devices.
- b) Reproduce the output signal (V_{eff} at the same frequency as sinusoidal shape) to lighting devices to check the photometrical performances.

It could be necessary to supply several samples in order to test the product.

5.2.2 Speed ranges

Because this system is depending on the cycle's movement, we are defining three speed ranges.

5.2.2.1 Very low speed: below 5 km/h

No requirement.

5.2.2.2 Low speed: from 5 km/h to 15 km/h

The light output level should be in conformity with the position ("to be seen") function according to ISO 6742-1:2015, 4.2 (Front position lamp), 4.3 (Rear lamp) and 4.7 (Direction indicators).

It is allowed that the light is flashing.

5.2.2.3 Normal running speed: above and from 15 km/h

No visible flashing.

Photometrical performances should comply with corresponding category of the light included into the system.

5.3 Safety requirements

5.3.1 Environmental behaviour

This system should match the same requirements than any other corresponding product as described in ISO 6742-1 and ISO 6742-3.

But it should withstand any speed up to 50 km/h.

5.3.2 Test method

5.3.2.1 Test method to check photometrical requirements

The requirements above should be tested from 5 km/h to 15 km/h.

If a stand-light is available, the system shall be operated for 2 min at 15 km/h, then stop and test.

5.3.2.2 Test method to check behaviour at a speed of 50 km/h

Endurance test is conducted first at 30 km/h for 30 min. Then speed is increased to 50 km/h in 5 s, and held at 50 km/h for 10 s. Then steadily reduce speed down to 0 km/h.

If the system could be switched on and off while cycle is being ridden, switch it on and off 10 times at 30 km/h.

6 Common requirements and test methods for lighting systems and the loading

6.1 Requirements

6.1.1 Corrosion resistance

The lighting equipment shall still be functional after testing according to the test method described in [6.2.1](#).

6.1.2 Water resistance

The lighting equipment shall still be functional after testing according to the test method described in [6.2.2](#).

6.1.3 Loading requirements

The loading shall still be functional after testing according to the test method described in [6.2.3](#).

6.2 Test methods

6.2.1 Corrosion testing

The entire lighting system (front lights, rear lights, dynamos in functional assembly conditions) shall undergo corrosion testing according to ISO 9227. A total of 96 h shall be run with a salt concentration of 5 %.

6.2.2 Water resistance

- Dynamos in functional assembly conditions shall undergo water spray testing according to IEC 60529, regarding class IPX4: protection against water sprays.
- Dynamo front lights and dynamo rear lights shall fulfil the class IPX3.

At the end of the test allow the unit to drain for 1 h.

6.2.3 Test of electronic load

The equipment shall be tested according to circuit in [Annex C](#).

7 Instructions

The instructions shall be provided with each lamp or system. These instructions can be provided in all types of format (paper, CD, website.) according to national regulations and shall be written in the language of the country where the lighting device is to be marketed or by visual tools, such as pictograms and illustrations shall feature prominently in the product safety information. When an electronic format is provided, a paper version shall be available upon request. The customer shall be made aware of this information either by the manufacturer or the retailer. Instructions for use shall contain the following information on:

- a) type of lamp;
- b) method for fitting the equipment to the bicycle;
- c) compatibility (output, input, connection);
- d) operation and adjustment.

Additional information may be provided at the discretion of the manufacturer.

8 Marking

8.1 Requirement

Both lamp and power sources shall be durably marked with:

- a) the manufacturer's name, abbreviation or trade-mark;
- b) the model name, production number, symbol or other identification;
- c) the rated input, output power, or anything to describe compatibility for open system.

Marking a) shall appear on the surfaces which is visible after assembled on the bicycle, in characters not less than 1 mm in height.

8.2 Durability test

8.2.1 Requirement

When tested by the method described in [8.2.2](#), the marking shall remain easily legible. It shall not be easily possible to remove any label nor shall any label show any sign of curling.

8.2.2 Test method

Rub the marking by hand for 15 s with a piece of cloth soaked in water and again for 15 s with a piece of cloth soaked in petroleum spirit.

Annex A (informative)

Electronic load for power-measurement of 6 V/1,5 W LED dynamos

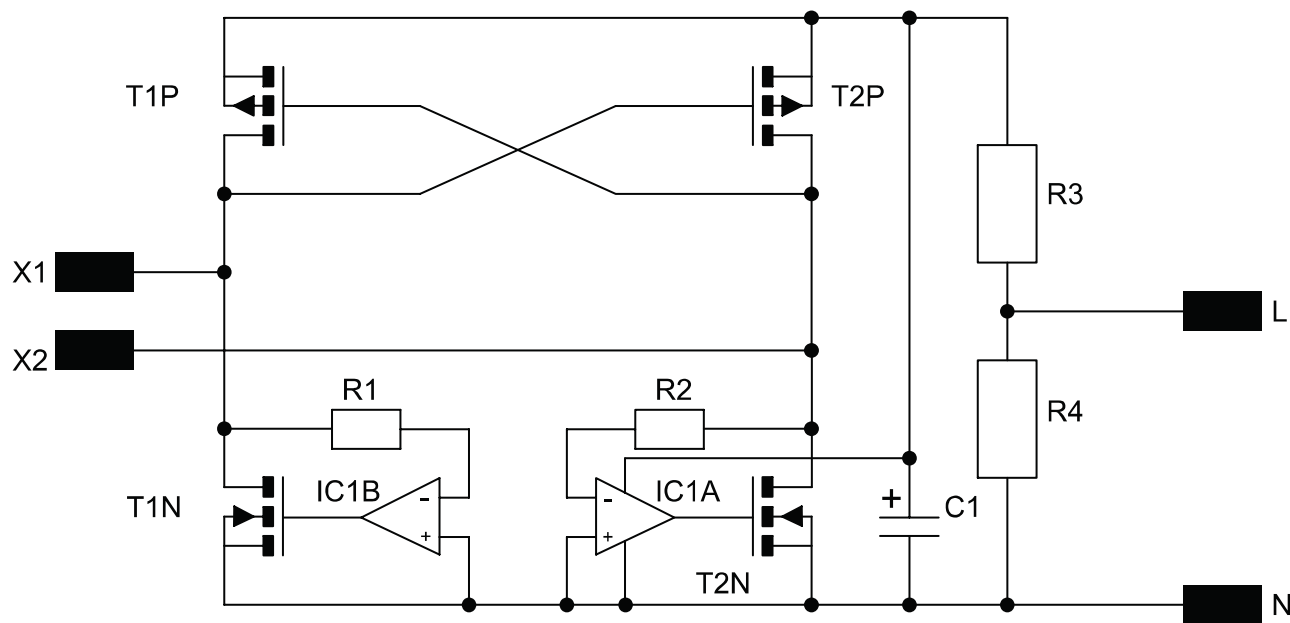

Key

Components

C1	capacitor $C = 1\,000\ \mu\text{F}$
IC1A	operational amplifier
IC1B	operational amplifier
T1N	N-Channel MOSFET
T2N	N-Channel MOSFET
T1P	P-Channel MOSFET
T2P	P-Channel MOSFET
R1	resistor $R = 1\ \text{M}\Omega$
R2	resistor $R = 1\ \text{M}\Omega$
R3	resistor $R = 10\ \Omega$
R4	resistor $R = 3,3\ \Omega$

Connections and supplies

X1,X2	terminal for dynamo
L,N	DC supply voltage with neutral

Figure A.1 — Electronic load for power-measurement of 6 V/1,5 W LED dynamos

The following components are needed for the measurement:

- a) T1P, T2P: P-Channel MOSFET [e.g. SI 4562 DY (one by one N- and P-Channel MOSFET)]
- b) T1N, T2N: N-Channel MOSFET [e.g. SI 4562 DY (one by one N- and P-Channel MOSFET)]
 - 1) Total Gate Charge: $Q_g < 50\ \text{nC}$
 - 2) Drain-Source Voltage: $U_{DS} > 30\ \text{V}$
 - 3) Drain-Source On-State resistance: $R_{DS(on)} < 50\ \text{m}\Omega$

- 4) Gate Threshold Voltage: $U_{GS(th)} < 1,6 \text{ V}$
- c) IC1A, IC1B: Operational amplifier (e.g. LM 2904)
 - 1) Input Bias Current: $I_{inBias} < 50 \text{ nA}$
 - 2) Input Offset Current: $I_{inOffset} < 5 \text{ nA}$
 - 3) Supply Voltage: $U_{supply} = 3 \text{ V to } 30 \text{ V}$
 - 4) Offset Voltage: $U_{offset} < 10 \text{ mV}$
 - 5) Output Voltage Swing $U_{outH} > V_{oc} - 1,4 \text{ V}$, $U_{outL} < 0,3 \text{ V}$
- d) R1 – R4: Resistor
 - 1) R1, R2: $1 \text{ M}\Omega$
 - 2) R3: 10Ω (1 %)
 - 3) R4: $3,3 \Omega$ (10 %)
- e) C1: Capacitor
 - 1) $1\,000 \mu\text{F}$ 25 V (20 %)
- f) Power supply: $3 \text{ V} \pm 30 \text{ mV}$, 1 A DC

The MOSFETs have to be enough cooled.

Annex B (informative)

Efficiency calculation

B.1 Efficiency calculation

The efficiency, η , can be calculated using the Formula (B.1):

$$\eta = \frac{P_{out}}{P_{in}} \times 100\% \quad (\text{B.1})$$

where

P_{out} is the electrical energy output (W);

P_{in} is the mechanical energy input (W).

P_{out} is calculated from Formula (B.2):

$$P_{out} = \frac{U^2}{R} \quad (\text{B.2})$$

where

U is the measured TRMS voltage at speed (V);

R is the resistance of the load (Ω).

P_{in} is calculated from Formula (B.3):

$$P_{in} = FM \times RM \times 2 \times \pi \times n \quad (\text{B.3})$$

where

FM is the measured force (N);

RM is the lever arm of force measurement (m);

n is the number of revolutions per second (rps) of a tyre.

Annex C (informative)

Verification of the electronic load

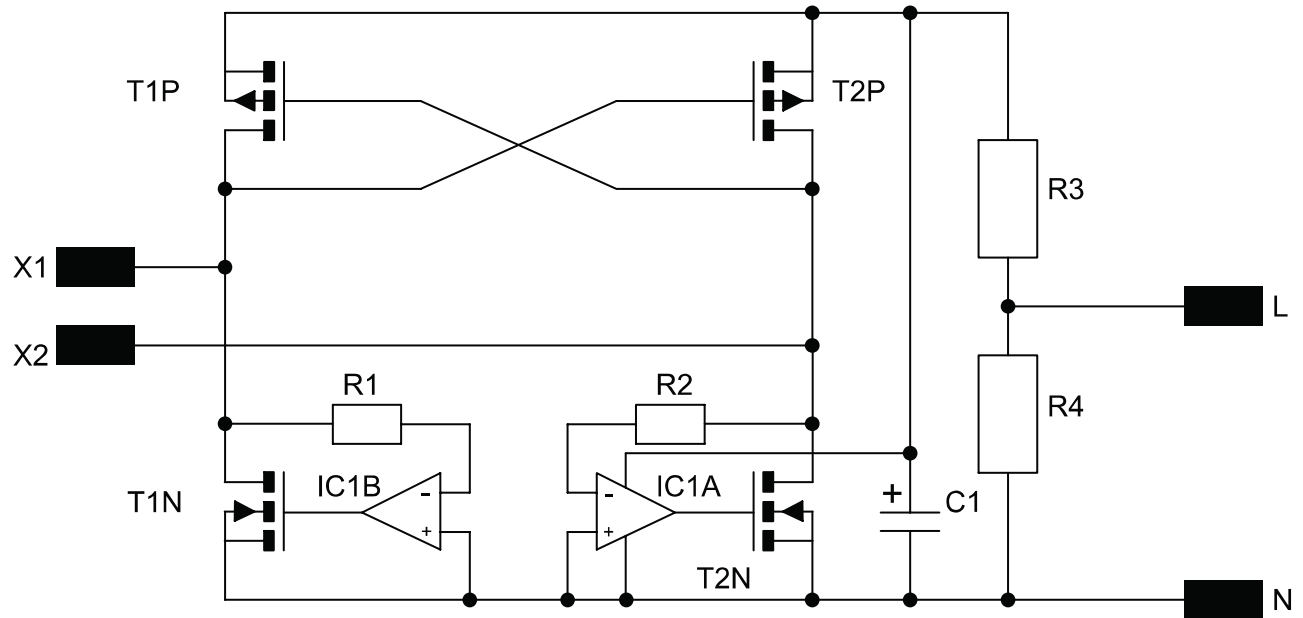

Key

Components

C1	capacitor $C = 1\,000\ \mu\text{F}$
IC1A	operational amplifier
IC1B	operational amplifier
T1N	N-Channel MOSFET
T2N	N-Channel MOSFET
T1P	P-Channel MOSFET
T2P	P-Channel MOSFET
R1	resistor $R = 1\ \text{M}\Omega$
R2	resistor $R = 1\ \text{M}\Omega$
R3	resistor $R = 10\ \Omega$
R4	resistor $R = 3,3\ \Omega$

Connections and supplies

X1,X2	terminal
L,N	DC supply voltage with neutral

Figure C.1 — Circuit diagram of electronic load applied in [Annex A](#)

Two power supplies and three multimeters are required for the verification of the electronic load.

Connect one power supply and one multimeter to L and N (please take care on the correct polarity) as for the usual measurement. Power supply shall be $3\ \text{V} \pm 10\ \text{mV}$, 1 A DC.

Connect a second power supply to X1 and X2. Measure the voltage U between X1 and X2 and the current I through the line at X1. Then start at 0 V and raise the voltage.

Change the polarity of the second power supply and repeat the test procedure. The requirement for the current I is the same as provided in [Table C.1](#).

Table C.1 — Voltage and current

Voltage, U V	1	2	3	4	5	6	7	8	9	10
Current, I mA	0	0	0	100	200	300	400	500	600	700
NOTE Tolerance $\pm 5\%$ applicable to current.										

After that you should change the polarity of the second power supply and verify the same table. At the conducting MOSFET (depending on the polarity) at 8 V not more than 25 mV between Drain and Source shall be measured.

Bibliography

- [1] ISO 4210 (all parts), *Cycles — Safety requirements for bicycles*
- [2] ISO 8098, *Cycles — Safety requirements for bicycles for young children*

