International Standard



6703/1

INTERNATIONAL ORGANIZATION FOR STANDARDIZATION • МЕЖДУНАРОДНАЯ ОРГАНИЗАЦИЯ ПО СТАНДАРТИЗАЦИИ • ORGANISATION INTERNATIONALE DE NORMALISATION

**Water quality — Determination of cyanide —
Part 1: Determination of total cyanide**

Qualité de l'eau — Dosage des cyanures — Partie 1: Dosage des cyanures totaux

First edition — 1984-09-01

UDC 543.2 : 546.267

Ref. No. ISO 6703/1-1984 (E)

Descriptors : water, quality, tests, determination, cyanides, water pollution.

Price based on 11 pages

Foreword

ISO (the International Organization for Standardization) is a worldwide federation of national standards bodies (ISO member bodies). The work of preparing International Standards is normally carried out through ISO technical committees. Every member body interested in a subject for which a technical committee has been established has the right to be represented on that committee. International organizations, governmental and non-governmental, in liaison with ISO, also take part in the work.

Draft International Standards adopted by the technical committees are circulated to the member bodies for approval before their acceptance as International Standards by the ISO Council. They are approved in accordance with ISO procedures requiring at least 75 % approval by the member bodies voting.

International Standard ISO 6703/1 was prepared by Technical Committee ISO/TC 147, *Water quality*.

Contents

Page

0	Introduction	1
1	Scope and field of application	1
2	Definition	2
Section one: Liberation and absorption of hydrogen cyanide		
3	Principle	3
4	Reagents	3
5	Apparatus	3
6	Sampling and samples	3
7	Procedure	5
Section two: Determination of cyanide ions — Photometric method with pyridine/barbituric acid		
8	Applicability	6
9	Principle	6
10	Reagents	6
11	Apparatus	6
12	Procedure	6
13	Expression of results	7
14	Precision	7
15	Test report	7
Section three: Determination of cyanide ions — Titrimetric method using the Tyndall effect		
16	Applicability	8
17	Principle and reactions	8
18	Reagents	8
19	Apparatus	8
20	Procedure	8
21	Expression of results	9
22	Precision	9
23	Test report	9

Section four: Determination of cyanide ions — Titrimetric method using an indicator

24	Applicability	10
25	Principle	10
26	Reagents	10
27	Apparatus	10
28	Procedure	10
29	Expression of results	10
30	Test report	11
	Bibliography	11

Water quality — Determination of cyanide — Part 1: Determination of total cyanide

Attention is drawn to the toxicity of cyanide and to the need to take extreme care when handling cyanides and their solutions.

Carry out all operations in a fume cupboard. Avoid contact with the skin and eyes. When pipetting, always use a safety pipette (pipette by bulb). Detoxify samples and solutions containing cyanides or heavy metals in accordance with local official regulations.

Other chemicals specified in this part of ISO 6703 are also hazardous, for example pyridine.

0 Introduction

Cyanides may be present in water as hydrocyanic acid (prussic acid), as cyanide ions and as complex cyanides. They may be determined as total cyanide or as easily liberatable cyanide. If cyanide compounds are chlorinated, cyanogen chloride (CICN) is produced, and this compound has to be determined separately.

This International Standard comprises four parts as follows:

- Part 1: Determination of total cyanide
- Part 2: Determination of easily liberatable cyanide
- Part 3: Determination of cyanogen chloride
- Part 4: Determination of cyanide by diffusion at pH 6¹⁾

The methods described in parts 1, 2 and 3 are suitable for controlling the quality of water and for the examination of municipal sewage and industrial effluents. They are appropriate to the technology available for the destruction of cyanides in treatment plants, and are based on the separation of liberated hydrogen cyanide (or in the case of ISO 6703/3, of cyanogen chloride) by stripping with a carrier gas.

The method specified in part 4 is suitable for the determination of smaller amounts of cyanide, depending on the concentrations of copper and nickel.

This part of ISO 6703 comprises four sections. Section one deals with the liberation and absorption of hydrogen cyanide. The other three sections deal with alternative methods for the quantitative determination of cyanide ions, as follows:

- photometric method with pyridine/barbituric acid (section two);

- titrimetric method using the Tyndall effect (section three);

- titrimetric method using an indicator (section four).

The specification of three alternative methods is necessary because each of the methods has its advantages and disadvantages. None can be quoted as applicable in all cases.

The applicability of each method is described in clauses 8, 16 and 24.

NOTE — Due to the different chemical behaviour of cyanide-containing or cyanide-producing substances, it is not possible to specify only one method for the quantitative determination of cyanide ions.

1 Scope and field of application

This part of ISO 6703 specifies three methods for the determination of total cyanide (see clause 2) in water.

The methods are applicable to water containing less than 100 mg of cyanide per litre, but higher concentrations may be determined by suitable dilution of the sample.

The methods and corresponding ranges of cyanide contents for which they are suitable are as follows:

- Photometric method with pyridine/barbituric acid : 0,002 to 0,025 mg;
- Titrimetric method using the Tyndall effect : > 0,005 mg;
- Titrimetric method using an indicator : > 0,05 mg.

1) At present at the stage of draft.

A large number of ions and compounds interfere with the determination. These are listed in the table 1, together with the concentrations below which they do not interfere (the list is not exhaustive). If present singly or in combination, up to the limiting concentrations, they do not interfere with the separation of hydrogen cyanide. The presence of aldehydes, e.g. formaldehyde, causes low cyanide values because of the formation of cyanohydrin.

If any of the limiting concentrations of the interferences is likely to be exceeded, the sample shall be diluted with distilled water before stabilization (see clause 6).

Other interference may arise from the presence of fatty acids, which will distil and form soaps during titration of alkaline solution, and from the presence of elementary sulfur.

2 Definition

For the purpose of this International Standard, the following definition applies.

total cyanide: Simple and complex bound cyanides including organic compounds containing cyanogen groups forming hydrogen cyanide under the conditions of this method. Cyanohydrins are detected in part. CN-groups of compounds defined as such may partly or completely form cyanide ions or hydrocyanic acid respectively in water. Mononitriles (R-CN), cyanate and thiocyanate ions and cyanogen chloride are not included.

Table 1 — Interferences

Interference	Limiting concentration, mg/l
Sulfide ions	1 000
Polysulfide ions	500
Sulfide and polysulfide ions	1 000
Sulfide ions	500
Thiosulfate ions	1 000
Thiocyanate ions	1 000
Carbonate ions	1 000
Cyanate ions	1 000
Nitrate ions	500
Nitrite ions	500
Ammonium ions	2 000
Iron(II) and iron(III) ions	5 000
Silver ions	50
Mercury ions	50
Chromate ions	300
Propionic acid	1 000
Phenol	1 000
Anthracene	100
Naphthalene	100
Anisaldehyde	10
Piperonal	10
Pyrrrole	100
Pyridine	10
Chlorine (elemental)	250
Hydrogen peroxide	10
Perborate ions	10

Section one: Liberation and absorption of hydrogen cyanide

3 Principle

Heating the sample with hydrochloric acid in the presence of copper(I) ions. Entrainment of the liberated hydrogen cyanide in a current of air into an absorption vessel containing sodium hydroxide solution.

NOTES

1 Complex cobalt cyanides will not be determined quantitatively, because, according to their concentrations, they are decomposed to the extent of between 5 and 15 % only, this also applies to some organocyanide compounds.

2 The effect of the specified digestion procedure on cyanohydrine is not fully characterized.

4 Reagents

All reagents shall be of recognized analytical grade and the water used shall be distilled or deionized water.

4.1 Hydrochloric acid, solution, ρ 1,12 g/ml.

4.2 Hydrochloric acid, solution, $c(\text{HCl}) = 1 \text{ mol/l}$.

4.3 Sodium hydroxide, solution, $c(\text{NaOH}) = 1 \text{ mol/l}$.

4.4 Sodium hydroxide, solution, $c(\text{NaOH}) = 5 \text{ mol/l}$.

4.5 Tin(II) chloride, solution.¹⁾

Dissolve 50 g of tin(II) chloride dihydrate ($\text{SnCl}_2 \cdot 2\text{H}_2\text{O}$) in 40 ml of the hydrochloric acid solution (4.2) and dilute with water to 100 ml.

Prepare a fresh solution each week.

4.6 Phenolphthalein, solution, containing chloroform.

Dissolve 0,03 g of phenolphthalein in 90 ml of ethanol and add 10 ml of chloroform.

4.7 Zinc- and cadmium sulfate, solution.¹⁾

Dissolve 100 g of zinc sulfate heptahydrate ($\text{ZnSO}_4 \cdot 7\text{H}_2\text{O}$) and 100 g of cadmium sulfate octahydrate ($3\text{Cd SO}_4 \cdot 8\text{H}_2\text{O}$) in water and dilute with water to 1 000 ml.

4.8 Copper(II) sulfate, solution.

Dissolve 200 g of copper(II) sulfate pentahydrate ($\text{CuSO}_4 \cdot 5\text{H}_2\text{O}$) in water and dilute with water to 1 000 ml.

4.9 Cadmium acetate, solution.¹⁾

Dissolve 300 g of cadmium acetate dihydrate [$\text{Cd}(\text{CH}_3\text{COO})_2 \cdot 2\text{H}_2\text{O}$] in water and dilute with water to 1 000 ml.

4.10 Buffer solution, of pH 5,4.

Dissolve 6 g of sodium hydroxide (NaOH) in approximately 50 ml water, add 11,8 g of succinic acid ($\text{C}_4\text{H}_6\text{O}_4$) and dilute with water to 100 ml.

5 Apparatus

Usual laboratory equipment, and

5.1 Apparatus for the separation of hydrogen cyanide by stripping.

The apparatus shown in figure 1, or its equivalent, is recommended and comprises the following components.

5.1.1 Three-necked distillation flask, of capacity 500 ml, with standard conical joints (centre neck 29/32, side necks 14,5/23).

5.1.2 Reflux condenser (Liebig condenser).

5.1.3 Absorption vessels, protected against return of liquid.

5.1.4 Funnel.

5.1.5 Flowmeter.

5.1.6 Wash bottle, of capacity 250 ml, for purification of the air.

5.2 pH meter, with a glass electrode which will fit into the side necks of the distillation flask.

5.3 One-mark volumetric flasks, of capacities 25, 50, 250 and 1 000 ml.

6 Sampling and samples

If the sample contains undissolved cyanides, it is necessary to ensure homogeneous distribution of the undissolved substances in the sample and its dilutions. Immediately after sampling, add 5 ml of the sodium hydroxide solution (4.4), 10 ml of the phenolphthalein solution (4.6) and 5 ml of the tin(II) chloride solution (4.5) to each litre of sample or diluted

1) SnCl_2 is added as a reducing agent; zinc salt is added to provide stable zinc hexacyanoferrates, cadmium salts are added as sulfide acceptor and because of their bactericidal effect.

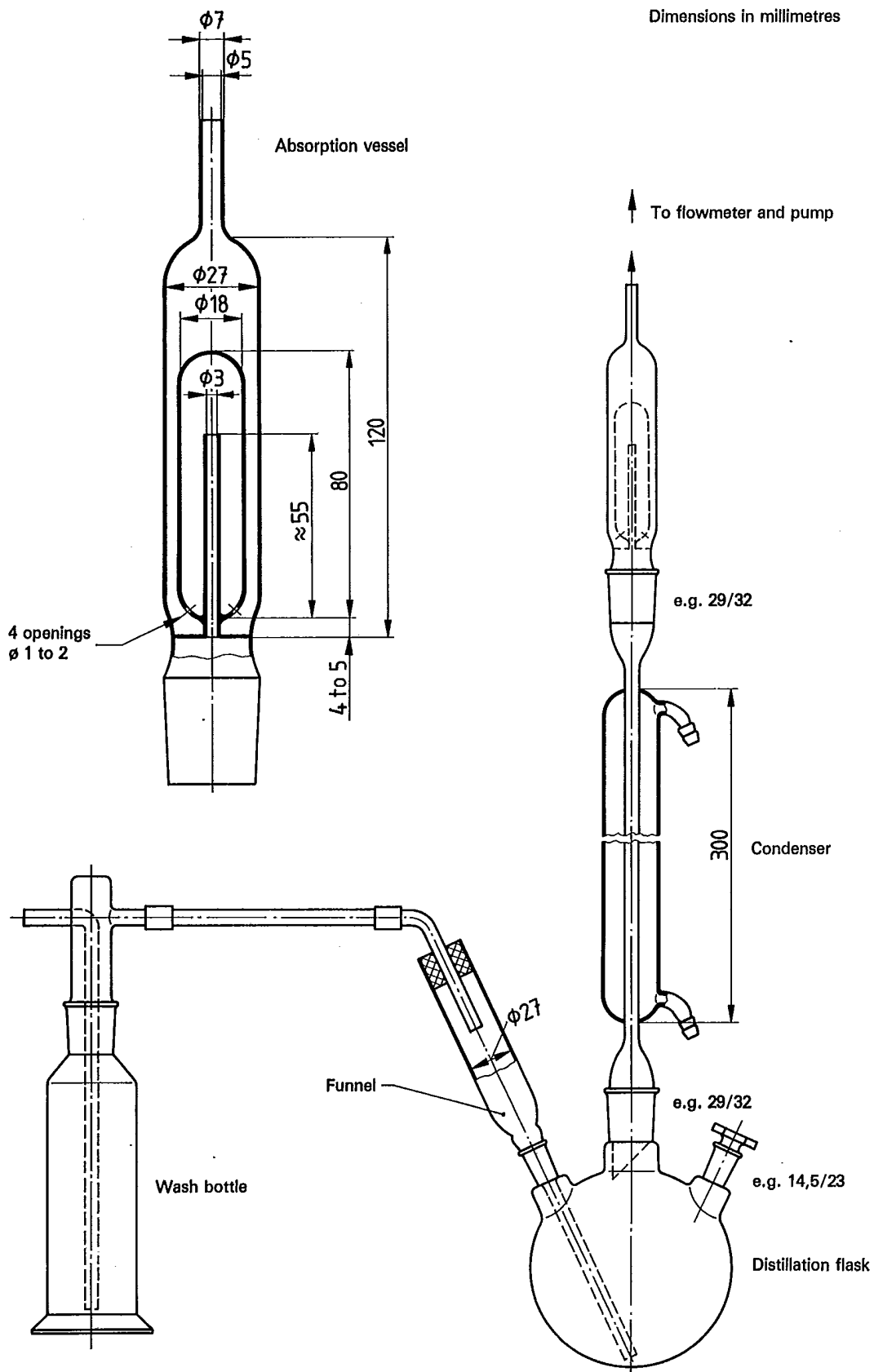

Figure 1 — Apparatus for separation of hydrogen cyanide by stripping

sample. Adjust the pH to about 8 by adding the hydrochloric acid solution (4.2), or the sodium hydroxide solution (4.3), drop by drop, until the water turns slightly red. Adjust the pH values of highly coloured samples in the same way after checking with the pH-meter (5.2) or with an indicator paper. Finally, add 10 ml of the zinc- and cadmium sulfate solution (4.7) to each litre of sample.

Analyse the sample as soon as possible. If it is necessary to store it, keep it cool and in the dark.

After addition of the zinc- and cadmium sulfate solution, a precipitate which may contain hexacyanoferrate, is formed. Accordingly, the sample should be rendered homogeneous immediately prior to taking aliquot portions. If replicate determinations are to be carried out, the aliquot portions shall be taken as quickly as possible in order to minimize any losses of gaseous hydrogen cyanide due to disturbance of the equilibrium between the gaseous hydrogen cyanide and the hydrocyanic acid in the liquid phase of the pretreated sample. If the required volume of sample is already known before sampling, it is advisable to take only this volume and to carry out the determination on the whole sample.

7 Procedure

7.1 Liberation and absorption of hydrogen cyanide

Pour 10 ml of the sodium hydroxide solution (4.3) into the absorption vessel (5.1.3), connect the vessel to the condenser,

connect the suction tube and adjust the air flow rate to 20 l/h. Pour into the distillation flask, in the following order, 30 ml of water, 10 ml of the copper(II) sulfate solution (4.8), 2 ml of the tin(II) chloride solution (4.5), 100 ml of the sample (see clause 6) and 10 ml of the hydrochloric acid solution (4.1). Connect the wash bottle containing approximately 100 ml of the sodium hydroxide solution (4.3), to the funnel and heat the flask until the contents boil. Readjust the air flow rate to 20 l/h. Allow to reflux at a rate of 1 to 2 drops per second.

If low cyanide concentrations (less than 0,1 mg/l) are expected, the volume of the sample may be increased to 200 ml. In this case, increase the volumes of the copper(II) sulfate solution (4.8) to 20 ml, of the tin(II) chloride solution (4.5) to 4 ml and of the hydrochloric acid solution (4.1) to 20 ml.

After 1 h, discontinue boiling.¹⁾

7.2 Blank test

Carry out a blank test in parallel with the determination, proceeding as specified in 7.1 and section two, three or four as appropriate, but replacing the sample by cyanide-free water treated in the same way as the sample (see clause 6).

7.3 Quantitative determination of cyanide ions

Proceed as specified in section two (photometric method with pyridine/barbituric acid), section three (titrimetric method with end-point determination using the Tyndall effect) or section four (titrimetric method using an indicator).

1) If the content of the absorption vessel is turbid or if interference is expected (for example if the sample contains more than 1 000 mg of sulfide or fatty acids), repeat the boiling and stripping procedure.

Transfer the contents of the absorption vessel through the funnel into a second distillation flask containing 10 ml of the cadmium acetate solution (4.9) and 40 ml of the buffer solution (4.10).

Rinse the absorption vessel with approximately 60 ml of water and add the washings to the contents of the distillation flask. Repeat the procedure by filling the absorption vessel, heating and stripping as described in 7.1 without adding further reagents.

Section two: Determination of cyanide ions — Photometric method with pyridine/barbituric acid

8 Applicability

This method may be applied to absorption solutions which contain 0,002 to 0,025 mg of cyanide. Absorption solutions with higher cyanide contents may be diluted with the sodium hydroxide solution (10.1).

The method is not applicable if oxides of nitrogen or sulfur dioxide reach the absorption vessel during separation of the cyanides. Other interferences include substances that influence the action of the chloramine-T solution.

In addition, coloured or turbid absorption solutions and absorption solutions containing compounds forming dyes cannot be analysed by this method.

In view of these possible interferences, it is recommended that the results are checked by titration with silver nitrate solution (see sections three and four).

9 Principle

Reaction of the cyanide ions with the active chlorine of chloramine-T, leading to the formation of cyanogen chloride which reacts with pyridine to form a glutacondialdehyde, which, in turn, condenses with two moles of barbituric acid to form a red-violet dye.

10 Reagents

All reagents shall be of recognized analytical grade and the water used shall be distilled or deionized water.

10.1 Sodium hydroxide, solution,
 $c(\text{NaOH}) = 0,4 \text{ mol/l}$.

10.2 Potassium cyanide (KCN).

10.3 Chloramine-T, solution.

Dissolve 0,5 g of chloramine-T trihydrate ($\text{C}_7\text{H}_7\text{ClNNaO}_2\text{S}\cdot 3\text{H}_2\text{O}$) in water in a 50 ml one mark volumetric flask and dilute to the mark.

Prepare a fresh solution each week.

10.4 Pyridine/barbituric acid, solution.

Place 3 g of barbituric acid ($\text{C}_4\text{H}_4\text{N}_2\text{O}_3$) in a 50 ml one-mark volumetric flask, wash down the walls of the flask with just

enough water to moisten the barbituric acid add 15 ml of pyridine ($\text{C}_5\text{H}_5\text{N}$) and swirl to mix. Add 3 ml of the hydrochloric acid solution (4.1) and dilute to the mark with water.

Store overnight in a refrigerator and, if necessary, filter to eliminate any undissolved barbituric acid.

The solution is stable for 1 day if stored in the dark and for 1 week if stored in a refrigerator.

10.5 Potassium cyanide, standard solution corresponding to 10 mg of CN^- per litre.

Dissolve 25 mg of potassium cyanide (KCN) in the sodium hydroxide solution (10.1) and dilute with the same sodium hydroxide solution to 1 000 ml in a one-mark volumetric flask.

Standardize this solution by titration with the silver nitrate solution (18.1), immediately before use or once each day if numerous determinations are carried out.

11 Apparatus

Usual laboratory equipment, and

11.1 Photometer, with cells of optical path length 10 mm.

12 Procedure

12.1 Transfer the contents of the absorption vessel to a 25 ml one-mark volumetric flask. Rinse the absorption vessel three times with approximately 3 ml portions of water, transfer the rinsings to the flask, dilute to the mark with water and mix.

Transfer, by means of a pipette, 10 ml of this solution into a second 25 ml one-mark volumetric flask, and add whilst mixing, 2 ml of the buffer solution (4.10), 4 ml of the hydrochloric acid solution (4.2) and 1 ml of the chloramine-T solution (10.3). Stopper the flask and leave for 5 ± 1 min.

Add 3 ml of the pyridine/barbituric acid solution (10.4), dilute with water to the mark and mix.

Measure the absorbance at 578 nm in a cell of optical path length 10 mm against a reference liquid¹⁾. Carry out the measurement 20 ± 5 min after addition of the pyridine/barbituric acid solution.

Measure the absorbance of the blank test solution (7.2) similarly.

¹⁾ Prepare this reference liquid using 10 ml of the sodium hydroxide solution (10.1) instead of the absorption solution.

12.2 Preparation of calibration graph

12.2.1 Preparation of standard solutions

Transfer, by means of a pipette 2, 5, 20 and 25 ml respectively of the standard potassium cyanide solution (10.5) into a series of four 250 ml one-mark volumetric flasks. Dilute to the mark with the sodium hydroxide solution (10.1) and mix.

Proceed as specified in 12.1, second and third paragraphs.

12.2.2 Photometric measurements

Proceed as specified in 12.1, fourth paragraph.

12.2.3 Plotting the graph

Plot a graph of absorbance against the cyanide contents, in milligrams, of the solutions. The relationship between absorbance and concentration is linear. Check the graph from time to time, especially if new packages of chemicals are used.

Check the absolute values of the standard solutions by titration with silver nitrate solution.

13 Expression of results

The total cyanide concentration, expressed in milligrams per litre, is given by the formula

$$\frac{(m_a - m_b) \times 1\,000}{f_1 f_2 V_s}$$

where

m_a is the cyanide content, in milligrams, of the test solution read from the calibration graph;

m_b is the cyanide content, in milligrams, of the blank test solution;

V_s is the volume, in millilitres, of the sample;

$f_1 = 0,4$, as only 40 % of the contents of the absorption vessel are used for the determination;

$f_2 = 0,97$, as the volume of the sample is increased by the addition of preservatives immediately after sampling. This factor is lowered by 0,01 for each 10 ml, if, during neutralization, more than 10 ml of reagent were used for each litre of sample.

Report results in milligrams per litre, taking into account the precision shown in table 2.

14 Precision

The precision data shown in table 2 were obtained in inter-laboratory trials; the samples were taken from the ground water of a landfill area.

15 Test report

The test report shall include the following information:

- the reference of the method used (i.e. ISO 6703/1, photometric method);
- the results and the method of expression used;
- any unusual features noticed during the determination;
- details of any operating procedures not specified in sections one and two of this part of ISO 6703, or regarded as optional, together with any incidents likely to have affected the results.

Table 2 — Precision data (photometric method)

Sample	Number of laboratories	Cyanide content mg/l	Comparative variation coefficient %
Potassium hexacyanoferrate(III) solution	14	4,4	8
Stabilized sample	17	0,60	28
Stabilized sample with addition of potassium hexacyanoferrate(III)	17	1,0	25

Section three: Determination of cyanide ions — Titrimetric method using the Tyndall effect

16 Applicability

This method may be applied to absorption solutions which contain more than 0,005 mg of cyanide.

The method is not applicable if the absorption solution is turbid, although slightly turbid solutions may still be titrated. In many cases, highly turbid solutions can be "cleaned up" by shaking with 1 to 2 ml of carbon tetrachloride. Phase separation may be accelerated by using a centrifuge.

17 Principle and reactions

Formation of complex silver cyanide ions in accordance with the equation:

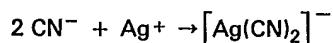

which, in the presence of an excess of silver ions causes precipitation of silver cyanide:

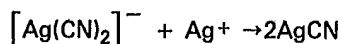

The addition of potassium iodide improves the detection of the end-point (as the solubility product of silver iodide is lower than that of silver cyanide):

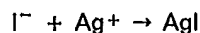

The formation of colloidal silver iodide is indicated by the Tyndall effect.

18 Reagents

All reagents shall be of recognized analytical grade and the water used shall be distilled or deionized water.

18.1 Silver nitrate, solution, $c(\text{AgNO}_3) = 0,01 \text{ mol/l}$.

18.2 Silver nitrate, solution, $c(\text{AgNO}_3) = 0,001 \text{ mol/l}$.

Store this solution, and the burette in which it is used, in the dark. Check the titre of the solution at frequent intervals or prepare fresh solutions prior to each use from the silver nitrate solution (18.1).

18.3 Potassium iodide, solution.

Dissolve 20 g of potassium iodide in water and dilute with water to 100 ml.

19 Apparatus (see figure 2)

Usual laboratory equipment, and

19.1 Automatic (dark glass) burette, of capacity 10 ml, capable of measuring volumes to an accuracy of 0,005 ml, or, if an automatic burette is not available, a **microburette**.

19.2 Magnetic stirrer with a black platform and black stirring bar.

19.3 High intensity light source, for example a microscope lamp with an adjustable focussing lens and a diaphragm, or a slide projector with a diaphragm or a double-beam lamp with fibre-optics system. The diameter of the aperture shall be 4 to 6 mm.

19.4 Titration vessels, made of glass, unmarked, of internal diameter about 25 mm and capacity 20 ml.

20 Procedure

Transfer the contents of the absorption vessel into a 25 ml one-mark volumetric flask. Rinse the vessel three times with approximately 3 ml portions of water, transfer the rinsings to the flask, dilute to the mark with water and mix.

The titration should preferably be performed in a darkened room.

Place the volumetric flask in the light beam (see figure 2). If the solution is turbid, see clause 16. If a Tyndall effect is not clearly visible, transfer, by means of a pipette, two 10 ml aliquot portions of the solution to two titration vessels (19.4) and add 1 drop of the potassium iodide solution (18.3) to each.

Place one titration vessel on the magnetic stirrer and add the stirring bar. Place the other vessel between the first one and the light source (see figure 2). If a double-beam lamp is used, place the vessels side by side. Immerse the tip of the burette containing the silver nitrate solution (18.2) in the solution, switch on the magnetic stirrer and start the titration. Titrate slowly because the formation of silver iodide is slow.

The end-point is reached when the turbidity caused by the Tyndall effect is clearly visible. This can be easily recognized by comparison with the reference sample to which the silver nitrate solution has not been added. Record the volume of the silver nitrate solution used. If this volume is more than 5 ml, transfer, by means of a pipette, two smaller aliquot portions (for example 1 ml) of the solution in the volumetric flask to titration vessels and add the sodium hydroxide solution (10.1) to bring the total volume up to 10 ml. Repeat the titration.

Exchange the titration vessels and transfer the stirring bar. Titrate the second solution to the same degree of turbidity as the first one and record the volume of silver nitrate solution used.

Proceed similarly using the blank test solution. The total volume of silver nitrate solution used in the two titrations in this blank test is usually 0,02 ml, but it shall not exceed 0,04 ml in each case.

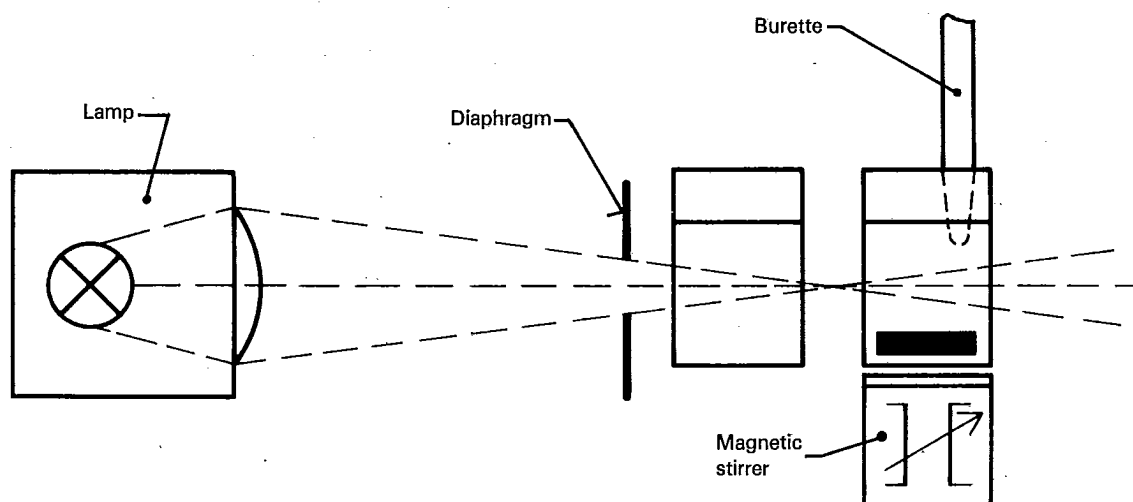

Figure 2 — Apparatus for determination of cyanide ions using Tyndall effect

21 Expression of results

The total cyanide concentration, expressed in milligrams per litre, is given by the formula

$$\frac{(V_1 + V_2 - V_0) \times f_1 \times 1\,000}{f_2 f_3 V_s}$$

where

V_0 is the total volume, in millilitres, of silver nitrate solution (18.2) required for the two titrations in the blank test;

V_1 is the volume, in millilitres, of silver nitrate solution (18.2) required for the first titration

V_2 is the volume, in millilitres, of silver nitrate solution (18.2) required for the second titration;

V_s is the volume, in millilitres, of the sample;

$f_1 = 0,052$, i.e. the mass, in milligrams, of CN^- equivalent to 1 ml of 0,001 mol/l silver nitrate solution;

$f_2 = 0,8$, as only 80 % of the contents of the absorption vessel are taken for titration;

$f_3 = 0,97$, as the volume of the sample is increased by the addition of preservatives immediately after sampling. This

factor is lowered by 0,01 for each 10 ml, if, during neutralization, more than 10 ml of reagent were used for each litre of sample.

Report results in milligrams per litre, taking into account the precision shown in table 3.

22 Precision

The precision data shown in table 3 were obtained in inter-laboratory trials; the samples were taken from the ground water of a landfill area.

23 Test report

The test report shall include the following information:

- the reference of the method used (i.e. ISO 6703/1, titrimetric method using the Tyndall effect);
- the results and the method of expression used;
- any unusual features noticed during the determination;
- details of any operating procedures not specified in sections one and three of this part of ISO 6703, or regarded as optional, together with any incidents likely to have affected the results.

Table 3 — Precision data (titrimetric method)

Sample	Number of laboratories	Cyanide content mg/l	Comparative variation coefficient %
Potassium hexacyanoferrate(III) solution	14	4,5	11
Stabilized sample	17	0,62	31
Stabilized sample with addition of potassium hexacyanoferrate(III)	17	1,0	21

Section four: Determination of cyanide ions — Titrimetric method using an indicator

24 Applicability

This method may be applied to absorption solutions containing more than 0,05 mg of cyanide.

The method is not applicable if the absorption solution is coloured or highly turbid¹⁾.

25 Principle

Titration of the contents of the absorption vessel with silver nitrate solution, the silver ions, when in excess, forming a red silver complex with 5-(4-dimethylaminobenzylidene) rhodanine.

26 Reagents

All reagents shall be of recognized analytical grade and the water used shall be distilled or deionized water.

The reagents specified in clause 18, together with

26.1 Indicator solution.

Dissolve 0,02 g of 5-(4-dimethylaminobenzylidene) rhodanine in acetone and dilute with acetone to 100 ml.

This solution is stable for about 1 week if kept in the dark.

27 Apparatus

Usual laboratory equipment, and

27.1 Magnetic stirrer, with bar.

27.2 Burette, of capacity 10 ml.

27.3 Titration vessels, made of glass, of capacity 50 ml.

28 Procedure

Transfer the contents of the absorption vessel into a 50 ml beaker. Rinse the vessel three times with approximately 5 ml portions of water and add the rinsings to the beaker. Add

0,1 ml of the indicator solution (26.1), immerse the tip of the burette containing the silver nitrate solution (18.2) in the solution, switch on the magnetic stirrer and titrate until the colour changes from yellow to red.

The colour is stable only for a short time.

If more than 10 ml of the silver nitrate solution (18.2) are necessary, carry out the titration using the silver nitrate solution (18.1).

Proceed similarly using the blank solution.²⁾

The volume of the silver nitrate solution (18.2) used in this blank test is usually 0,08 ml, but it shall not exceed 0,2 ml.

29 Expression of results

The total cyanide concentration, expressed in milligrams per litre, is given by the formula

$$\frac{(V_1 - V_0) \times f_1 \times 1\,000}{f_2 V_s}$$

where

V_0 is the volume, in millilitres, of silver nitrate solution (18.2) required for the blank test;

V_1 is the volume, in millilitres, of silver nitrate solution (18.2) required for the titration;

V_s is the volume, in millilitres, of the sample;

$f_1 = 0,052$, i.e. the mass, in milligrams, of CN^- equivalent to 1 ml of 0,001 mol/l silver nitrate solution;

$f_2 = 0,97$, as the volume of the sample is increased by the addition of preservatives immediately after sampling. This factor is lowered by 0,01 for each 10 ml, if, during neutralization, more than 10 ml of reagent were used for each litre of sample.

Report the result to the nearest 0,1 mg/l.

NOTE — If the 0,01 mol/l silver nitrate solution was used, an appropriate correction should be made.

1) The method may be carried out potentiometrically in which case it can be used for coloured or highly turbid solutions.

2) Prepare this blank test solution using 10 ml of the sodium hydroxide solution (4.3) and 20 ml water.

30 Test report

The test report shall include the following information:

- a) the reference of the method used (i.e. ISO 6703/1, titrimetric method using an indicator;
- b) the results and the method of expression used;

- c) any unusual features noticed during the determination;
- d) details of any operating procedures not specified in sections one and four of this part of ISO 6703, or regarded as optional, together with any incidents likely to have affected the results.

Bibliography

MERTENS, H., *Z.f. Wasser und Abwasser-Forschung*, **9**, (1976), pp. 183-195.

MERTENS, H., *Vom Wasser*, **52**, (1979), pp. 61-74.
