**Internal combustion engines — Piston
rings —**

**Part 1:
Rectangular rings made of cast iron**

Moteurs à combustion interne — Segments de piston —

Partie 1: Segments rectangulaires en fonte moulée



PDF disclaimer

This PDF file may contain embedded typefaces. In accordance with Adobe's licensing policy, this file may be printed or viewed but shall not be edited unless the typefaces which are embedded are licensed to and installed on the computer performing the editing. In downloading this file, parties accept therein the responsibility of not infringing Adobe's licensing policy. The ISO Central Secretariat accepts no liability in this area.

Adobe is a trademark of Adobe Systems Incorporated.

Details of the software products used to create this PDF file can be found in the General Info relative to the file; the PDF-creation parameters were optimized for printing. Every care has been taken to ensure that the file is suitable for use by ISO member bodies. In the unlikely event that a problem relating to it is found, please inform the Central Secretariat at the address given below.

© ISO 2003

All rights reserved. Unless otherwise specified, no part of this publication may be reproduced or utilized in any form or by any means, electronic or mechanical, including photocopying and microfilm, without permission in writing from either ISO at the address below or ISO's member body in the country of the requester.

ISO copyright office
Case postale 56 • CH-1211 Geneva 20
Tel. + 41 22 749 01 11
Fax + 41 22 749 09 47
E-mail copyright@iso.org
Web www.iso.org

Published in Switzerland

Contents

Page

Foreword.....	iv
Introduction	v
1 Scope.....	1
2 Normative references	1
3 Overview	1
4 Ring types and designation examples.....	2
4.1 Type R — Straight faced rectangular ring	2
4.2 Type B — Barrel faced rectangular ring	3
4.3 Type BA — Asymmetrical barrel faced rectangular ring $h_1 \geq 1,5$ mm.....	4
4.4 Type M — Taper faced rectangular ring	5
5 Common features.....	6
5.1 Type R — Straight faced rectangular ring	6
5.2 Type B — Barrel faced rectangular ring	8
5.3 Type BA — Asymmetrical barrel faced rectangular ring $h_1 \geq 1,5$ mm.....	9
5.4 Type M — Taper faced rectangular ring	10
5.5 Type R, B, BA and M rings (positive twist type) — Internal bevel or internal step top side	12
5.6 Type M rings (negative twist type), tapers M3 to M5 — Internal bevel or internal step bottom side.....	13
5.7 Type R, B, BA and M rings (positive twist type), and Type M rings (negative twist type) — Defined twist feature (IFV and IFVU).....	14
5.8 Type R, B and BA rings — Outside chamfered edges (KA).....	15
5.9 Type R, B, BA and M rings — Inside chamfered edges (KI)	15
5.10 Type R, B and BA rings — Outside and inside chamfered edges (KA + KI)	15
5.11 Type R, B, BA and M rings (fully faced, semi-inlaid and inlaid) — Plating/coating thickness.....	17
6 Force factors	17
7 Dimensions	18
Bibliography	30

Foreword

ISO (the International Organization for Standardization) is a worldwide federation of national standards bodies (ISO member bodies). The work of preparing International Standards is normally carried out through ISO technical committees. Each member body interested in a subject for which a technical committee has been established has the right to be represented on that committee. International organizations, governmental and non-governmental, in liaison with ISO, also take part in the work. ISO collaborates closely with the International Electrotechnical Commission (IEC) on all matters of electrotechnical standardization.

International Standards are drafted in accordance with the rules given in the ISO/IEC Directives, Part 2.

The main task of technical committees is to prepare International Standards. Draft International Standards adopted by the technical committees are circulated to the member bodies for voting. Publication as an International Standard requires approval by at least 75 % of the member bodies casting a vote.

Attention is drawn to the possibility that some of the elements of this document may be the subject of patent rights. ISO shall not be held responsible for identifying any or all such patent rights.

ISO 6622-1 was prepared by Technical Committee ISO/TC 22, *Road vehicles*.

This second edition cancels and replaces the first edition (ISO 6622-1:1986), which has been technically revised.

ISO 6622 consists of the following parts, under the general title *Internal combustion engines — Piston rings*:

- *Part 1: Rectangular rings made of cast iron*
- *Part 2: Rectangular rings made of steel*

Introduction

ISO 6622 is one of a number of series of International Standards dealing with piston rings for reciprocating internal combustion engines. Others are ISO 6621 [2], [3], [4], [5], ISO 6623 [6], ISO 6624 [7], [8], [9], [10], ISO 6625 [11], ISO 6626 [12], [13] and ISO 6627 [14].

The common features and dimensional tables presented in this part of ISO 6622 constitute a broad range of variables and, in selecting a particular ring type, the designer must bear in mind the conditions under which it will be required to operate.

It is also essential that the designer refer to the specifications and requirements of ISO 6621-3 [4] and ISO 6621-4 before completing selection.

Internal combustion engines — Piston rings —

Part 1: Rectangular rings made of cast iron

1 Scope

This part of ISO 6622 specifies the essential dimensional features of rectangular rings made of cast iron, Types R, B, BA and M, having diameters up to and including 200 mm, used in reciprocating internal combustion piston engines. It is also applicable to piston rings of compressors working under similar conditions.

2 Normative references

The following referenced documents are indispensable for the application of this document. For dated references, only the edition cited applies. For undated references, the latest edition of the referenced document (including any amendments) applies.

ISO 6621-4, *Internal combustion engines — Piston rings — Part 4: General specifications*

3 Overview

The rectangular ring types are specified in Tables 1 to 3 and Figures 1 to 4. Their common features and the dimensions of those features are specified in Tables 4 to 8 and Figures 5 to 31. Tables 9 and 10 give the force factors for the different ring types, while Tables 11 and 12 give the dimensions and forces of rectangular rings of radial wall thickness *regular* and $D/22$, respectively.

4 Ring types and designation examples

4.1 Type R — Straight faced rectangular ring

4.1.1 General features

See Table 11 or 12 for dimensions and forces.

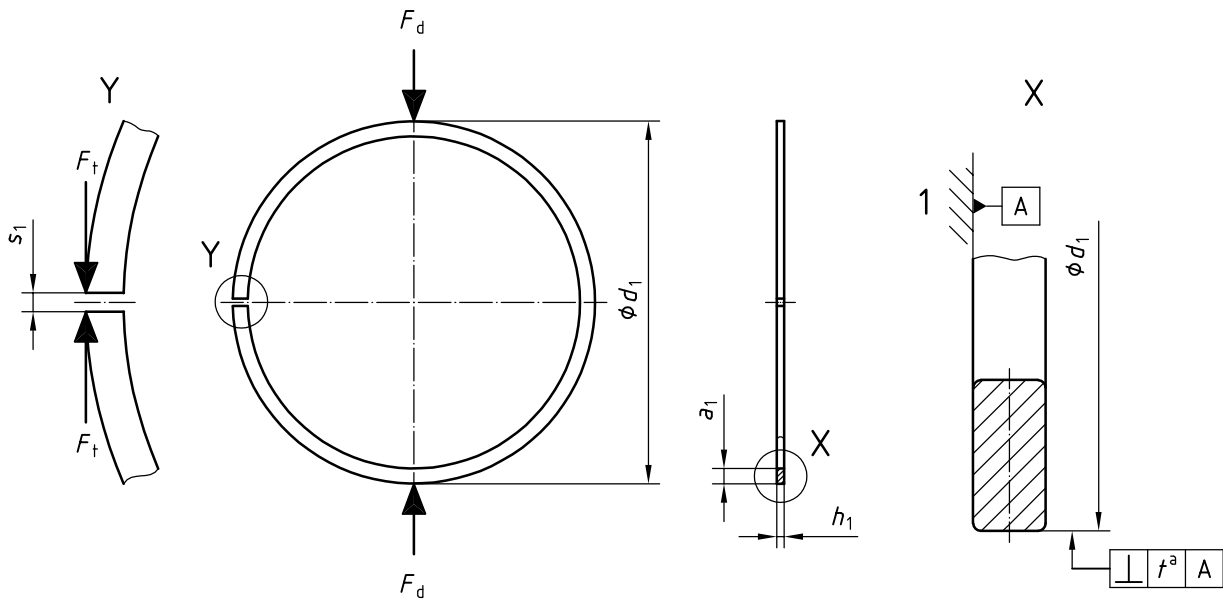

Key

1 reference plane

a $t = 0,005 \times h_1$.

Figure 1 — Type R

4.1.2 Designation

EXAMPLE Designation of a piston ring complying with the requirements of ISO 6622-1, being a rectangular ring made of cast iron, with a straight faced peripheral surface (R), of nominal diameter $d_1 = 90$ mm (90), of nominal ring width $h_1 = 2,5$ mm (2,5), made of non heat treated grey cast iron, subclass 12 (MC12), phosphated on all sides (PO):

Piston ring ISO 6622-1 R 90 × 2,5 - MC12/PO

4.2 Type B — Barrel faced rectangular ring

4.2.1 General features

See Table 11 or 12 for dimensions and forces.

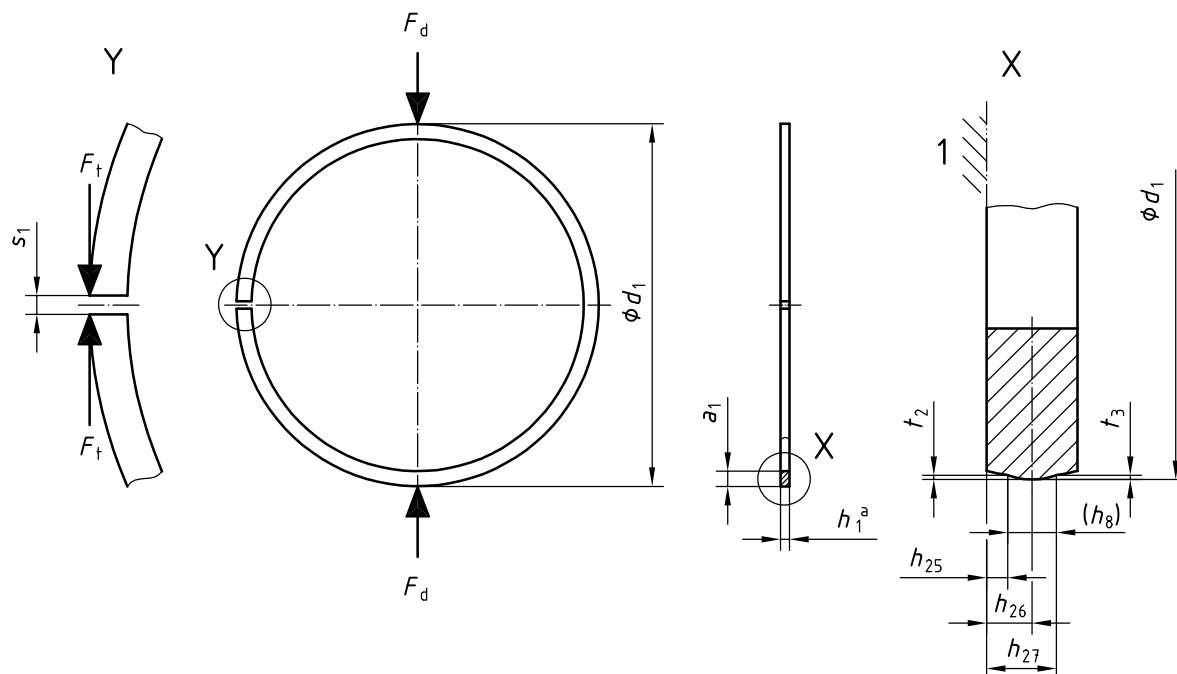

Key

1 reference plane

a See Table 1.

Figure 2 — Type B

Table 1 — Gauge width (h_g) and barrel dimensions for symmetrical barrel faced compression rings

Dimensions in millimetres

h_1	h_{25}^a	h_{26}	h_{26} tol.	h_{27}	t_2, t_3^b	h_g^c
1,2	0,30	0,60	$\pm 0,20$	0,90	0,003...0,012	0,60
1,5	0,35	0,75	$\pm 0,25$	1,15	0,003...0,015	0,80
1,75	0,35	0,85	$\pm 0,30$	1,35		1,00
2,0	0,40	1,00	$\pm 0,30$	1,60		1,20
2,5	0,45	1,25	$\pm 0,40$	2,05		1,60
3,0	0,50	1,50	$\pm 0,50$	2,50	0,005...0,020	2,00
3,5	0,55	1,75	$\pm 0,50$	2,95		2,40
4,0	0,60	2,00	$\pm 0,60$	3,40	0,005...0,023	2,80
4,5	0,65	2,25	$\pm 0,60$	3,85		3,20

a h_{25} may be lowered for rings with reduced edge dimensions.

b t_2 and/or t_3 can be changed as agreed between edge dimensions.

c Gauge width (h_g) only informative; may be used only if agreed between manufacturer and client.

4.2.2 Designation

EXAMPLE Designation of a piston ring complying with the requirements of ISO 6622-1, being a rectangular ring made of cast iron, with a barrel faced peripheral surface (B), of nominal diameter $d_1 = 90$ mm (90), of nominal width $h_1 = 2,5$ mm (2,5), made of heat-treated martensitic spheroidal graphite cast iron, subclass 51 (MC51), with a chromium plated coating on the peripheral surface, and of minimum thickness 0,15 mm (CR3):

Piston ring ISO 6622-1 - B 90 × 2,5 - MC51/CR3

4.3 Type BA — Asymmetrical barrel faced rectangular ring $h_1 \geq 1,5$ mm

4.3.1 General features

See Table 11 or 12 for dimensions and forces.

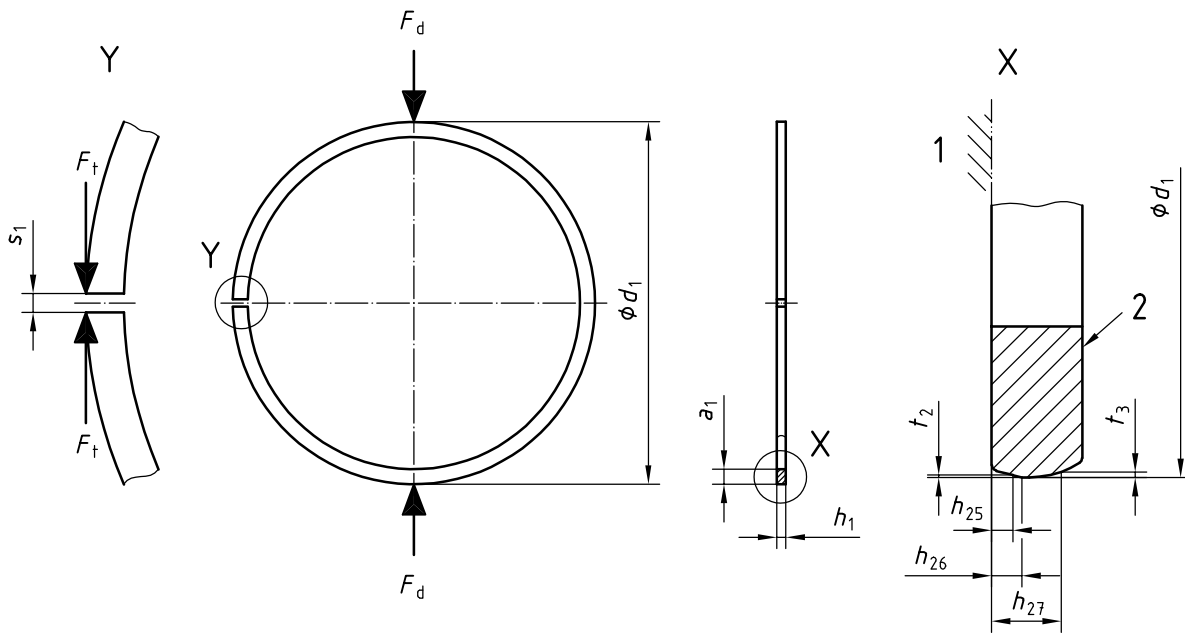

Key

- 1 reference plane
- 2 mark

Figure 3 — Type BA

Table 2 — Barrel dimensions

Dimensions in millimetres

h_1	h_{25}^a	h_{26}	h_{26} tol.	h_{27}	t_2^b	t_3^b
1,5	0,35	0,50	± 0,15	1,15	0...0,005	0,007...0,022
1,75	0,35	0,55	± 0,20	1,35	0...0,007	0,008...0,025
2,0	0,40	0,60		1,50		0,009...0,030
2,5	0,45	0,70	± 0,25	1,80	0...0,008	0,011...0,035
3,0	0,55	0,80		2,10		0,012...0,038
3,5	0,60	0,90	± 0,30	2,40	0...0,009	0,012...0,040
4,0	0,65	0,95		2,80		0,013... 0,045
4,5	0,70	1,05	± 0,35	3,20	0...0,010	0,015... 0,050

^a h_{25} may be lowered for rings with reduced edge dimensions.

^b t_2 and/or t_3 may be varied as agreed between manufacturer and client.

4.3.2 Designation

EXAMPLE Designation of a piston ring complying with the requirements of ISO 6622-1, being a rectangular ring made of cast iron, with an asymmetrical barrel faced peripheral surface (BA), of nominal diameter $d_1 = 90$ mm (90), of nominal width $h_1 = 2,5$ mm (2,5), made of heat-treated martensitic spheroidal graphite cast iron subclass 51 (MC51), and having a chromium plated coating on the peripheral surface with a minimum thickness of 0,15 mm (CR3):

Piston ring ISO 6622-1 BA 90 × 2,5 - MC51/CR3

4.4 Type M — Taper faced rectangular ring

4.4.1 General features

See Table 11 or 12 for dimensions and forces.

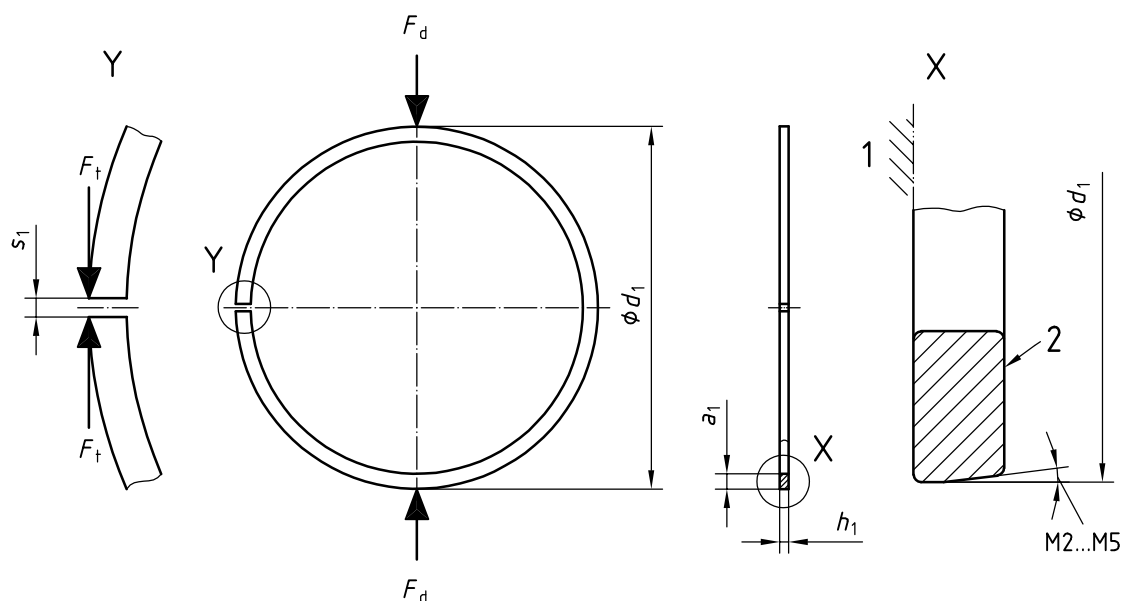

Key

- 1 reference plane
- 2 mark

Figure 4 — Type M

Table 3 — Taper

Dimensions in minutes

Code	Uncoated rings with peripheral surface turned and chromium plated or spray coated rings with peripheral surface ground and chromium plated rings with surface not ground ^a					
	Taper	Tolerance	with IF or IW (top side) ^b		with IFU or IWU (bottom side) ^{b, c}	
			Taper	Tolerance	Taper	Tolerance ^d
M1 ^c	10	$\begin{matrix} +40 \\ 0 \end{matrix}$	10	$\begin{matrix} +60 \\ 0 \end{matrix}$	—	—
M2	30	$\begin{matrix} +50 \\ 0 \end{matrix}$	30		—	—
M3	60		60		60	$\begin{matrix} +60 \\ 0 \end{matrix}$
M4	90		90		90	
M5	120		120		120	

^a For chromium plated rings with tapered peripheral surface not ground, the tolerance shall be increased by 10 (e.g. M3 = 60: $\begin{matrix} +60 \\ 0 \end{matrix}$ for M rings or $\begin{matrix} +70 \\ 0 \end{matrix}$ for M rings with IF or IW and IFU or IWU).

^b IF and IW, and IFU and IWU, are explained in Figures 22 to 25.

^c M1 should not be used for rings of width < 1,5 mm or for those with a partly cylindrical peripheral surface.

^d For M rings (negative twist type) M3, M4 and M5, the twist angle should not exceed 90 % of the minimum taper angle.

4.4.2 Designation

EXAMPLE Designation of a piston ring complying with the requirements of ISO 6622-1, being a rectangular ring made of cast iron, with a 10' taper faced peripheral surface (M1), of diameter $d_1 = 90$ mm (90), of nominal width $h_1 = 2,5$ mm (2,5), made of heat treated grey cast iron, subclass 23 (MC23) and having an inlaid spray coating on the peripheral surface with a minimum thickness of 0,1 mm (SC2F):

Piston ring ISO 6622-1 M1 90 x 2,5 - MC23/SC2F

5 Common features

5.1 Type R — Straight faced rectangular ring

5.1.1 Uncoated rings

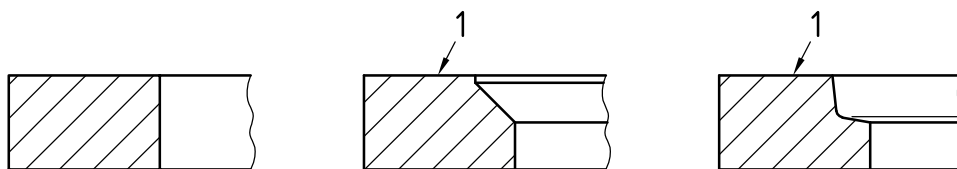

Key

1 mark

Figure 5 — Uncoated Type R rings

5.1.2 Chromium plated or spray coated rings

5.1.2.1 Fully faced

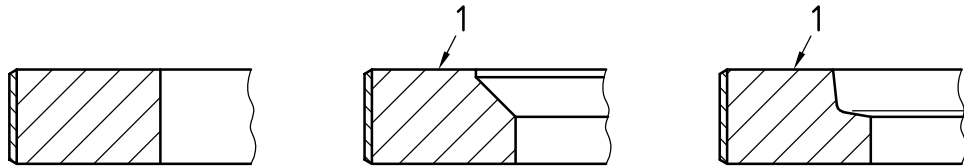

Key

1 mark

Figure 6 — Fully faced Type R rings

5.1.2.2 Semi-inlaid

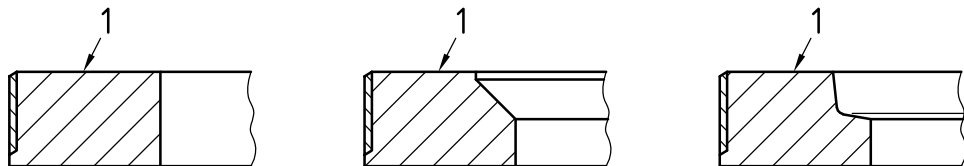

Key

1 mark

Figure 7 — Semi-inlaid Type R rings

5.1.2.3 Inlaid (inlaid chrome not recommended)

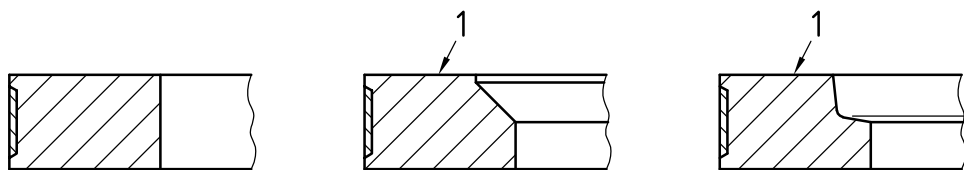

Key

1 mark

Figure 8 — Inlaid Type R rings

5.2 Type B — Barrel faced rectangular ring

5.2.1 Uncoated rings

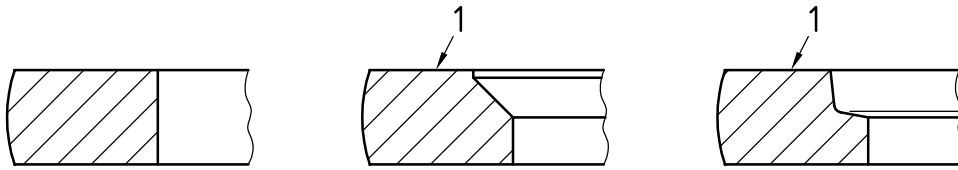

Key

1 mark

Figure 9 — Uncoated Type B rings

5.2.2 Chromium plated or spray coated rings

5.2.2.1 Fully faced

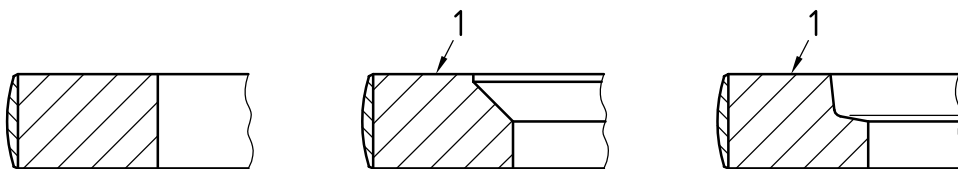

Key

1 mark

Figure 10 — Fully faced Type B rings

5.2.2.2 Semi-inlaid

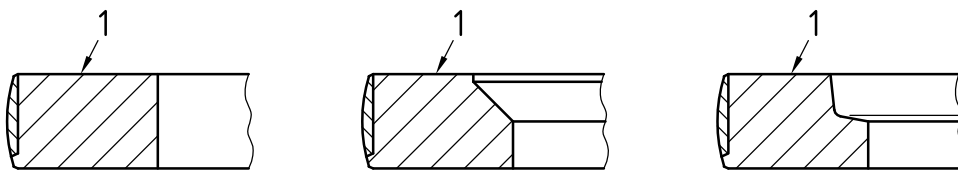

Key

1 mark

Figure 11 — Semi-inlaid Type B rings

5.2.2.3 **Inlaid** (inlaid chrome not recommended)

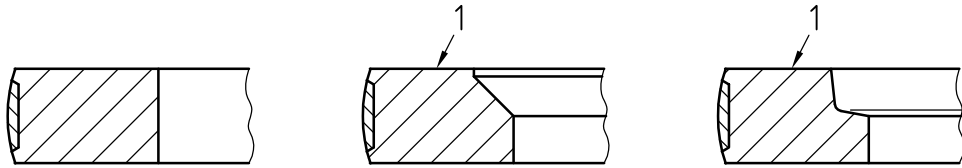

Key

1 mark

Figure 12 — Inlaid Type B rings

5.3 **Type BA — Asymmetrical barrel faced rectangular ring** $h_1 \geq 1,5$ mm

5.3.1 **Uncoated rings**

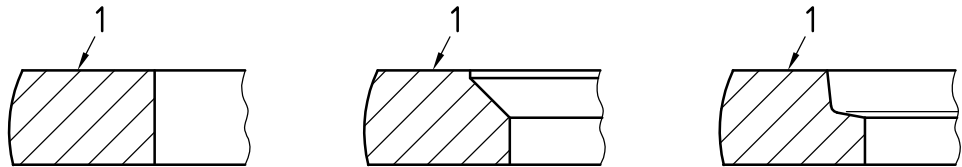

Key

1 mark

Figure 13 — Uncoated Type BA rings

5.3.2 **Chromium plated or spray coated rings**

5.3.2.1 **Fully faced**

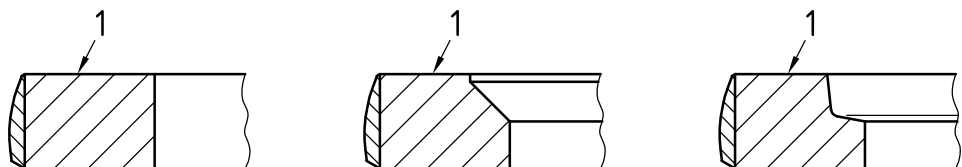

Key

1 mark

Figure 14 — Fully faced Type BA rings

5.3.2.2 Semi-inlaid

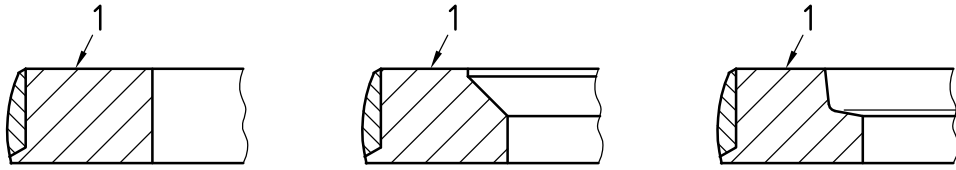

Key
1 mark

Figure 15 — Semi-inlaid Type BA rings

5.3.2.3 Inlaid (inlaid chrome not recommended)

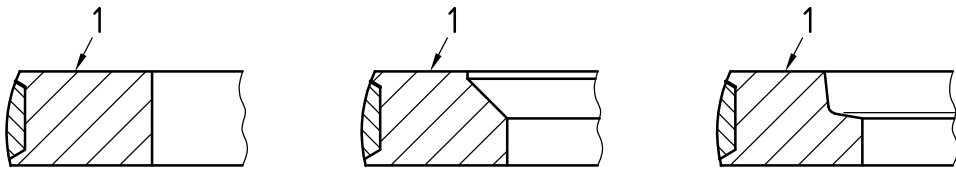

Key
1 mark

Figure 16 — Inlaid Type BA rings

5.4 Type M — Taper faced rectangular ring

5.4.1 Fully tapered

5.4.1.1 Uncoated rings

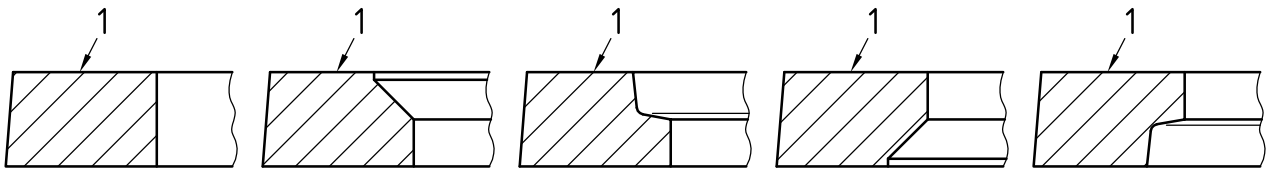

Key
1 mark

Figure 17 — Uncoated Type M rings

5.4.1.2 Chromium plated or spray coated rings

5.4.1.2.1 Fully faced

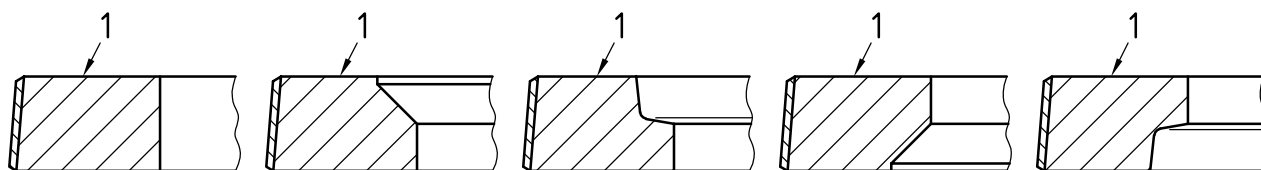

Key

1 mark

Figure 18 — Fully faced Type M rings

5.4.1.2.2 Semi-inlaid

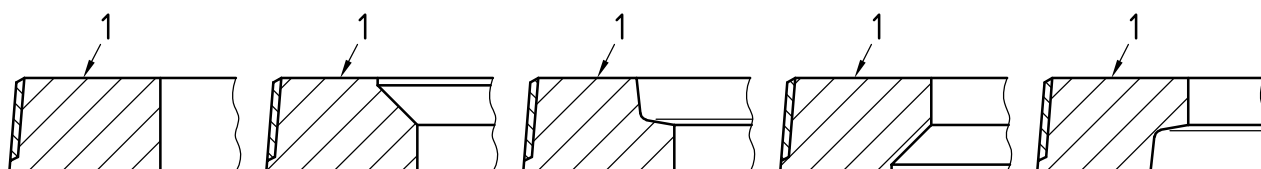

Key

1 mark

Figure 19 — Semi-inlaid Type M rings

5.4.1.2.3 Inlaid (inlaid chrome not recommended)

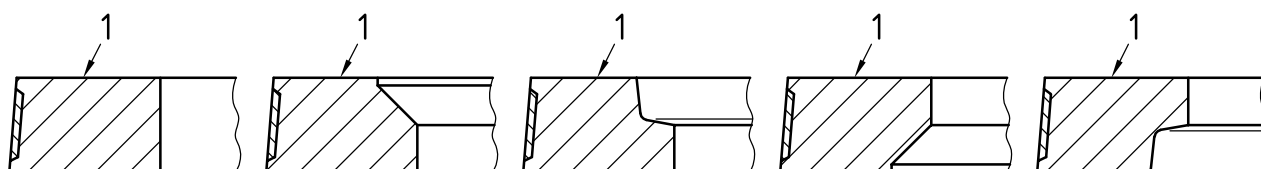

Key

1 mark

Figure 20 — Inlaid Type M rings

5.4.2 Taper faced rectangular ring with partly cylindrical machined (LM) or lapped (LP) peripheral surface

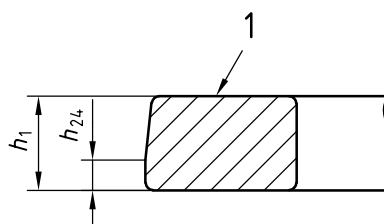

Key

1 mark

Figure 21 — Partly cylindrical machined or lapped Type M rings

Table 4 — Axial dimensions of the cylindrical part of peripheral surface h_{24}

Dimensions in millimetres

h_1	h_{24}^a max.	h_{24} max. each side of gap up to 30°
1,2	0,4	0,8
1,5	0,5	1,0
1,75	0,6	1,2
2,0	0,7	1,4
2,5	0,8	1,6
3,0	1,0	2,0
3,5	1,2	2,3
4,0	1,3	2,6
4,5	1,5	3,0

^a Partly cylindrical peripheral surface shall be visible.

5.5 Type R, B, BA and M rings (positive twist type) — Internal bevel or internal step top side

Dimensions in millimetres

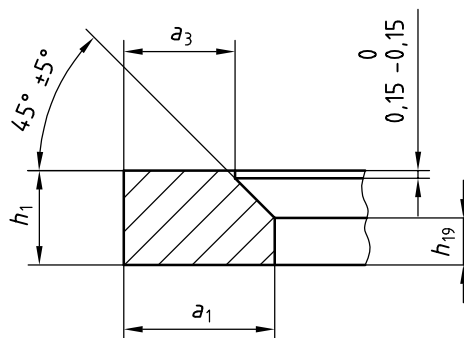

Figure 22 — Internal bevel top side (IF)

Dimensions in millimetres

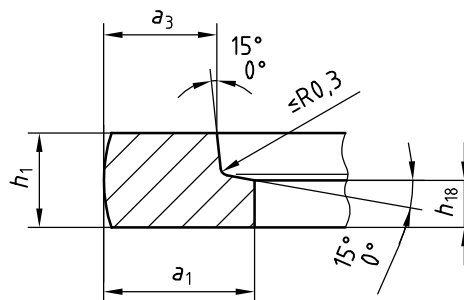
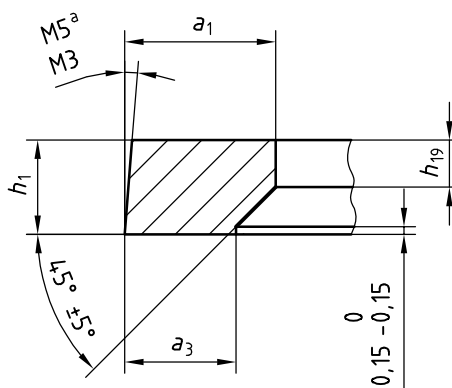

Figure 23 — Internal step top side (IW)

5.6 Type M rings (negative twist type), tapers M3 to M5 — Internal bevel or internal step bottom side

Dimensions in millimetres



a See Table 3.

Figure 24 — Internal bevel bottom side (IFU)

Dimensions in millimetres

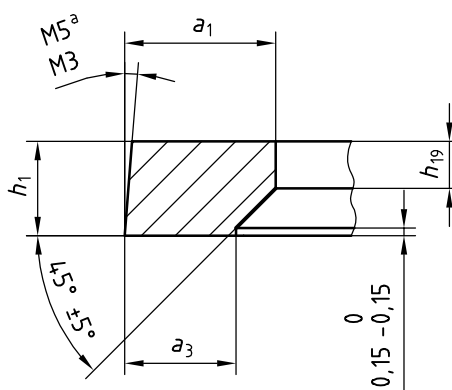

a See Table 3.

Figure 25 — Internal step bottom side (IWU)

Table 5 — a_3 , h_{18} and h_{19} dimensions for rings $h_1 < 1,5$ mm

Dimensions in millimetres

d_1	a_3^a		h_{18}, h_{19}	
		Tolerance		Tolerance
$30 \leq d_1 < 60$	$0,85 \times a_1$	$\begin{matrix} 0 \\ -0,2 \end{matrix}$	$0,6 \times h_1$	$\begin{matrix} 0 \\ -0,25 \end{matrix}$
$60 \leq d_1 \leq 90$	$0,9 \times a_1$	$\begin{matrix} 0 \\ -0,3 \end{matrix}$	$0,6 \times h_1$	$\begin{matrix} 0 \\ -0,25 \end{matrix}$

^a Dimension does not apply for IF and IFU rings because h_{19} is specified for this feature.

Table 6 — a_3 and h_{18} dimensions for rings $h_1 \geq 1,5\text{mm}$

Dimensions in millimetres

d_1	a_3		h_{18}	
		Tolerance		Tolerance
$30 \leq d_1 < 80$	$0,8 \times a_1$	$\begin{matrix} 0 \\ -0,2 \end{matrix}$	$0,6 \times h_1$	$\begin{matrix} 0 \\ -0,25 \end{matrix}$
$80 \leq d_1 < 100$	$0,8 \times a_1$	$\begin{matrix} 0 \\ -0,3 \end{matrix}$	$0,6 \times h_1$	$\begin{matrix} 0 \\ -0,25 \end{matrix}$
$100 \leq d_1 < 150$	$0,8 \times a_1$	$\begin{matrix} 0 \\ -0,3 \end{matrix}$	$0,6 \times h_1$	$\begin{matrix} 0 \\ -0,35 \end{matrix}$
$150 \leq d_1 \leq 200$	$0,8 \times a_1$	$\begin{matrix} 0 \\ -0,4 \end{matrix}$	$0,6 \times h_1$	$\begin{matrix} 0 \\ -0,45 \end{matrix}$

5.7 Type R, B, BA and M rings (positive twist type), and Type M rings (negative twist type) — Defined twist feature (IFV and IFVU)

When the standard twist of 0,01/0,05 for rings $\leq 2\text{ mm}$ axial width and 0,01/0,04 for rings $> 2\text{ mm}$ axial width per 2 mm of radial ring thickness is specified, the dimension a_x , the angle φ and the width of the bevel are at the discretion of the manufacturer. In such cases, the design should correspond to one or the other of the designs shown in Figure 26.

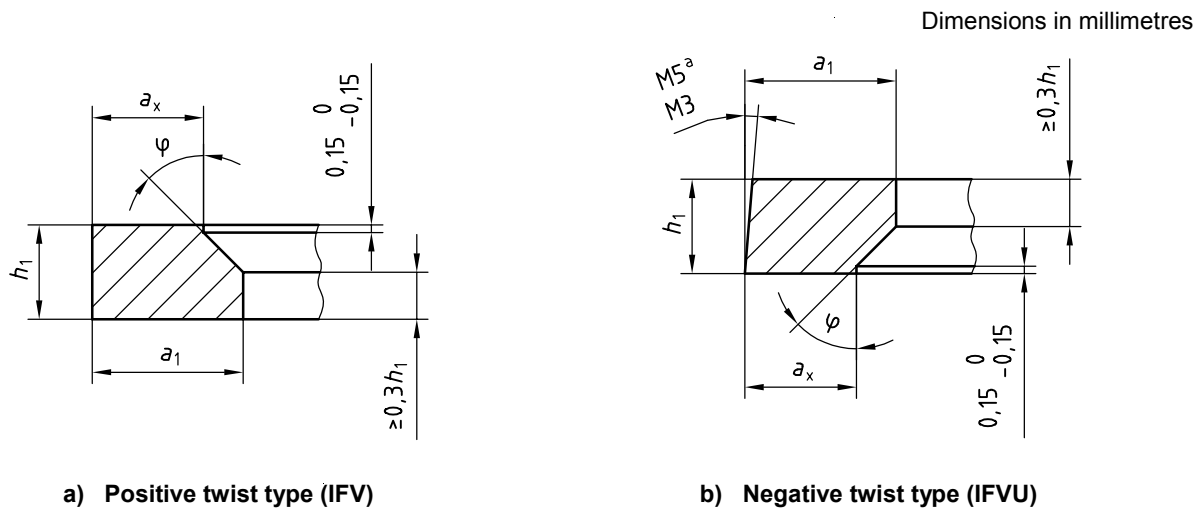

^a See Table 3.

Figure 26 — Variable internal bevel

5.8 Type R, B and BA rings — Outside chamfered edges (KA)

NOTE KA applies to uncoated rings only.

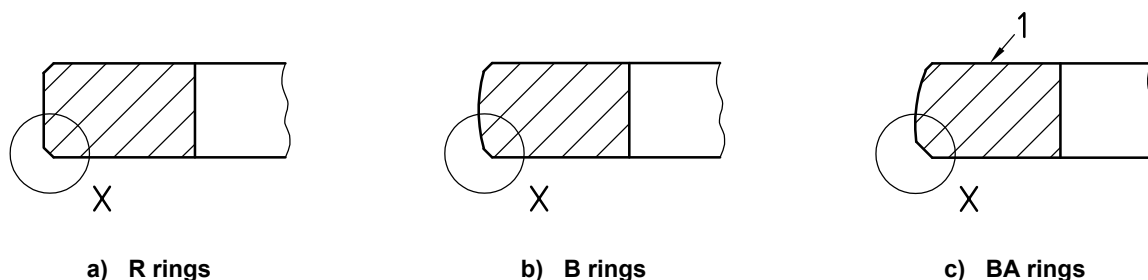

Key

1 mark

Figure 27 — Outside chamfered edges

5.9 Type R, B, BA and M rings — Inside chamfered edges (KI)

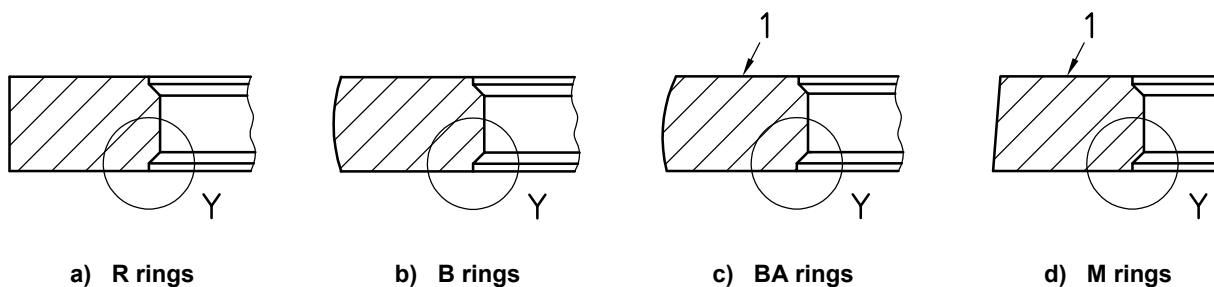

Key

1 mark

Figure 28 — Inside chamfered edges (KI)

5.10 Type R, B and BA rings — Outside and inside chamfered edges (KA + KI)

NOTE KA applies to uncoated rings only.

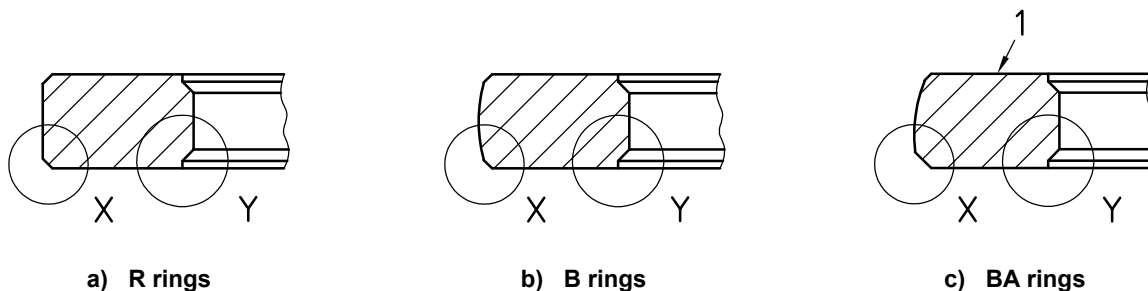

Key

1 mark

Figure 29 — Outside and inside chamfered edges (KA + KI)

Dimensions in millimetres

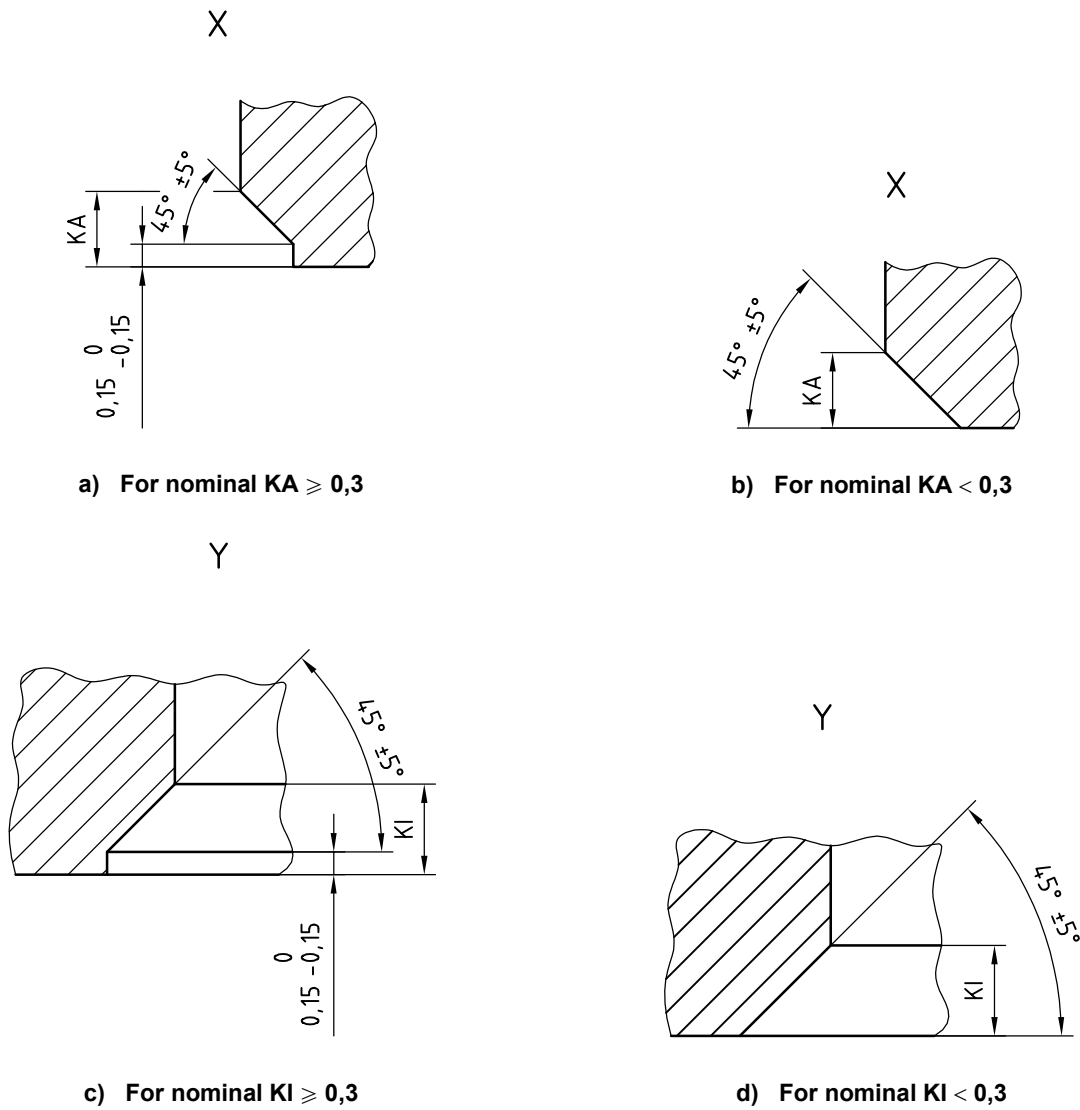

Figure 30 — Details of Figures 27, 28 and 29

Table 7 — KA and KI dimensions

Dimensions in millimetres

d_1	KA	KI
$30 \leq d_1 < 50$	$\leq 0,2$	$\leq 0,2$
$50 \leq d_1 < 125$	$0,3 \times 0,1$	$0,3 \times 0,15$
$125 \leq d_1 < 175$	$0,4 \times 0,1$	$0,4 \times 0,15$
$175 \leq d_1 \leq 200$	$0,5 \times 0,1$	$0,6 \times 0,20$

5.11 Type R, B, BA and M rings (fully faced, semi-inlaid and inlaid) — Plating/coating thickness

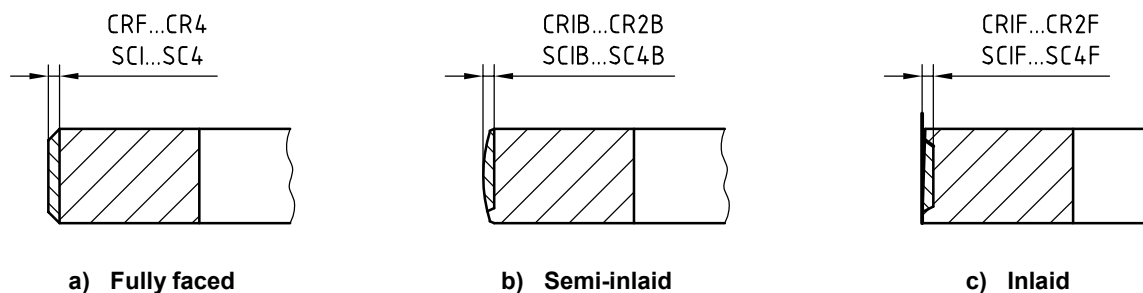

Figure 31 — Plating/coating thickness

Table 8 — Plating/coating thickness

Dimensions in millimetres

Chromium plating code	Spray coating code	Thickness min.
CRF	—	0,005
CR1	SC1	0,05
CR2	SC2	0,1
CR3 ^a	SC3 ^a	0,15
CR4 ^a	SC4 ^a	0,2
^a Not recommended for rings $h_1 \leq 1,2$.		

6 Force factors

The tangential and diametral forces given in Tables 11 and 12 shall be corrected when additional features and/or materials other than grey cast iron with a modulus of elasticity of 100 GN/m² are being used. For common features, the multiplier correction factors given in Tables 9 and 10 and the force correction factors given in ISO 6621-4 shall be used. The factors of Table 10 have been calculated with mean plating/coating thickness.

Table 9 — Force correction factors for R, B, BA and M rings with features KA, KI, IF, IW, IFU and IWU

d_1 mm	Factor					
	KA	KI	Taper			IF IFU
M2 or M3			M4 or M5			
$30 \leq d_1 < 50$	1	1	0,97	0,93	0,88	0,75
$50 \leq d_1 < 200$	0,97	0,97	0,98	0,96	0,88	0,78

Table 10 — Force correction factors for chromium plated or spray coated R, B, BA and M rings (fully faced, semi-inlaid and inlaid types)

d_1 mm	Factor					
	CRF	CR1	CR2/SC1	CR3/SC2	CR4/SC3	SC4
$30 \leq d_1 < 50$	1	0,81	0,70	0,64	—	—
$50 \leq d_1 < 75$	1	0,90	0,85	0,81	0,75	0,71
$75 \leq d_1 < 100$	1	0,92	0,88	0,85	0,81	0,77
$100 \leq d_1 < 125$	1	0,94	0,91	0,88	0,86	0,83
$125 \leq d_1 < 150$	1	0,95	0,92	0,90	0,88	0,85
$150 \leq d_1 \leq 200$	1	0,96	0,93	0,91	0,89	0,87

7 Dimensions

See Tables 11 and 12.

Table 11 — Dimensions of R, B, BA and M rectangular rings — Radial wall thickness “regular”

Dimensions in millimetres

Nominal diameter d_1	Radial wall thickness “regular” a_1		Ring width h_1					Closed gap s_1		Tangential force F_t N					Diametral force F_d N				
	Tolerance		Column					Tolerance		For h_1 shown in column					For h_1 shown in column				
			1	2	3	4	5			1	2	3	4	5	1	2	3	4	5
30	1,25														6,0	7,5	8,6	9,9	12,5
31	1,30														6,2	8,0	9,2	10,5	13,1
32	1,35														6,7	8,2	9,7	11,0	13,8
33	1,40														6,9	8,6	10,1	11,6	14,6
34	1,40														6,5	8,2	9,5	11,0	13,8
35	1,45														6,9	8,6	10,1	11,4	14,4
36	1,50														7,1	9,0	10,5	12,0	15,1
37	1,55														7,5	9,5	11,0	12,7	15,7
38	1,60														7,7	9,9	11,4	13,1	16,6
39	1,65														8,2	10,3	12,0	13,8	17,2
40	1,65	± 0,15 Within a ring: 0,15 max.													7,7	9,7	11,4	13,1	16,3
41	1,70														8,2	10,1	11,8	13,5	17,0
42	1,75		1,2	1,5	1,75	2	2,5								8,4	10,5	12,3	14,2	17,6
43	1,80														8,8	11,0	12,9	14,6	18,3
44	1,85														9,0	11,4	13,3	15,3	19,1
45	1,90													9,2	11,8	13,8	15,7	19,6	
46	1,90													9,0	11,2	13,1	15,1	18,7	
47	1,95													9,2	11,6	13,5	15,5	19,4	
48	2,00													9,7	12,0	14,0	16,1	20,2	
49	2,05													9,9	12,5	14,6	16,6	20,9	
50	2,10		4,8	6,0	7,0	8,0	10,0							10,3	12,9	15,1	17,2	21,5	
51	2,15		4,9	6,2	7,2	8,3	10,3							10,5	13,3	15,5	17,8	22,1	
52	2,15		4,7	5,9	6,9	7,9	9,9							10,1	12,7	14,8	17,0	21,3	
53	2,20		4,9	6,1	7,2	8,2	10,3							10,5	13,1	15,5	17,6	22,1	
54	2,25		5,0	6,3	7,4	8,5	10,6							10,8	13,5	15,9	18,3	22,8	

Table 11 (continued)

Dimensions in millimetres

Nominal diameter d_1	Radial wall thickness "regular" a_1	Ring width h_1					Closed gap s_1	Tangential force F_t N					Diametral force F_d N							
		Tolerance	1	2	3	4		5	Tolerance	1	2	3	4	5	Tolerance	1	2	3	4	5
55	2,30														11,2	14,0	16,3	18,7	23,4	
56	2,35						0,15	-0,010 -0,025 For phosphated PO surface: -0,005 -0,025	5,4	6,7	7,8	9,0	11,2		11,6	14,4	16,8	19,4	24,1	
57	2,40								5,5	6,9	8,1	9,2	11,6		11,8	14,8	17,4	19,8	24,9	
58	2,40							0,2	5,3	6,7	7,8	8,9	11,2		11,4	14,4	16,8	19,1	24,1	
59	2,45						5,5		6,9	8,0	9,2	11,5		11,8	14,8	17,2	19,8	24,7		
60	2,50							+0,2 0	5,6	7,0	8,2	9,4	11,7		12,0	15,1	17,6	20,2	25,2	
61	2,55						5,7		7,2	8,4	9,6	12,1		12,3	15,5	18,1	20,6	26,0		
62	2,60								5,9	7,4	8,6	9,9	12,4		12,7	15,9	18,5	21,3	26,7	
63	2,65								6,1	7,6	8,9	10,1	12,7		13,1	16,3	19,1	21,7	27,3	
64	2,65								5,9	7,3	8,6	9,8	12,3		12,7	15,7	18,5	21,1	26,4	
65	2,70								6,0	7,5	8,8	10,1	12,6		12,9	16,1	18,9	21,7	27,1	± 30 % if $F_d < 21,5$ N
66	2,75	± 0,15 Within a ring: 0,15 max.							6,2	7,7	9,0	10,3	12,9		13,3	16,6	19,4	22,1	27,7	
67	2,80			1,2	1,5	1,75	2	2,5	6,3	7,9	9,3	10,6	13,3		13,3	17,0	20,0	22,8	28,6	± 20 % if $F_d \geq 21,5$ N
68	2,85								6,5	8,1	9,5	10,9	13,6		14,0	17,4	20,4	23,4	29,2	
69	2,90								6,6	8,3	9,7	11,1	13,9		14,2	17,8	20,9	23,9	29,9	
70	2,90								6,4	8,1	9,4	10,8	13,5		13,8	17,4	20,2	23,2	29,0	
71	2,95								6,6	8,3	9,7	11,1	13,8		14,2	17,8	20,9	23,9	29,7	
72	3,00								6,7	8,5	9,9	11,3	14,2		14,4	18,3	21,3	24,3	30,5	
73	3,05								6,9	8,6	10,1	11,6	14,5		14,8	18,5	21,7	24,9	31,2	
74	3,10								7,1	8,8	10,3	11,8	14,8		15,3	18,9	22,1	25,4	31,8	
75	3,15								7,2	9,0	10,5	12,0	15,1		15,5	19,4	22,6	25,8	32,5	
76	3,15								7,0	8,8	10,2	11,7	14,7		15,1	18,9	21,9	25,2	31,6	
77	3,20						0,25	+0,25 0	7,1	8,9	10,5	12,0	15,0		15,3	19,1	22,6	25,8	32,3	
78	3,25								7,3	9,1	10,7	12,2	15,3		15,7	19,6	23,0	26,2	32,9	
79	3,30								7,4	9,3	10,9	12,5	15,6		15,9	20,0	23,4	26,9	33,5	

Table 11 (continued)

		Dimensions in millimetres																					
Nominal diameter d_1	Radial wall thickness "regular" a_1	Ring width h_1					Closed gap s_1	Tangential force F_t N					Diametral force F_d N										
		Column						For h_1 shown in column					For h_1 shown in column										
Tolerance		1	2	3	4	5	Tolerance					1	2	3	4	5	Tolerance						
80	3,35							7,6	9,5	11,1	12,7	16,0		16,3	20,4	23,9	27,3	34,4					
81	3,40							7,8	9,7	11,4	13,0	16,3		16,8	20,9	24,5	28,0	35,0					
82	3,40							7,6	9,5	11,1	12,7	15,9		16,3	20,4	23,9	27,3	34,2					
83	3,45							7,7	9,7	11,3	12,9	16,2		16,6	20,9	24,3	27,7	34,8					
84	3,50						0,25	7,9	9,9	11,5	13,2	16,5		17,0	21,3	24,7	28,4	35,5					
85	3,55		1,2	1,5	1,75	2		8,0	10,1	11,8	13,5	16,8		17,2	21,7	25,4	29,0	36,1					
86	3,60							8,2	10,3	12,0	13,7	17,2		17,6	22,1	25,8	29,5	37,0					
87	3,65							8,3	10,4	12,2	14,0	17,5		17,8	22,4	26,2	30,1	37,6					
88	3,65							8,1	10,2	11,9	13,6	17,1		17,4	21,9	25,6	29,2	36,8					
89	3,70							8,3	10,4	12,2	13,9	17,4		17,8	22,4	26,2	29,9	37,4					
90	3,75							12,3	14,1	17,6	21,2		26,4	30,3	37,8	45,6							
91	3,80							12,5	14,3	18,0	21,6		26,9	30,7	38,7	46,4							
92	3,85							12,8	14,6	18,3	22,0		27,5	31,4	39,3	47,3							
93	3,90							13,0	14,9	18,6	22,4		28,0	32,0	40,0	48,2							
94	3,90			1,75	2	2,5	3	12,7	14,5	18,2	21,9		27,3	31,2	39,1	47,1							
95	3,95							12,9	14,8	18,5	22,3		27,7	31,8	39,8	47,9							
96	4,00							13,2	15,1	18,8	22,6		28,4	32,5	40,4	48,6							
97	4,05							13,4	15,3	19,2	23,0		28,8	32,9	41,3	49,5							
98	4,10							13,6	15,6	19,5	23,4		29,2	33,5	41,9	50,3							
99	4,15							13,8	15,8	19,8	23,8		29,7	34,0	42,6	51,2							
100	4,15							15,5	19,4	23,3		33,3	41,7	50,1									
101	4,20							15,7	19,7	23,7		33,8	42,4	51,0									
102	4,25			2	2,5	3		16,0	20,0	24,0		34,4	43,0	51,6									
103	4,25							16,2	20,3	24,4		34,8	43,6	52,5									
104	4,30							15,9	19,9	23,9		34,2	42,8	51,4									

Table 11 (continued)

Dimensions in millimetres

Nominal diameter d_1	Radial wall thickness "regular" a_1					Ring width h_1					Closed gap s_1	Tangential force F_t N					Diametral force F_d N																							
	Tolerance					Column		Tolerance				For h_1 shown in column					Tolerance																							
						1	2	3	4	5							1	2	3	4	5																			
105	4,35																																							
106	4,40												0,3																											
107	4,40							2		2,5	3																													
108	4,45																																							
109	4,50																																							
110	4,55																																							
111	4,55																																							
112	4,60																																							
113	4,65																																							
114	4,70																																							
115	4,70																																							
116	4,75																																							
117	4,80																																							
118	4,85																																							
119	4,85																																							
120	4,90																																							
121	4,95																																							
122	4,95																																							
123	5,00																																							
124	5,05																																							
125	5,05																																							
126	5,10																																							
127	5,15																																							
128	5,20																																							
129	5,20																																							

± 0,20
Within
a ring:
0,20 max.

-0,010
-0,030
For
phosphated
PO surface:
0
-0,030

+0,25
0

± 30 % if
 $F_t < 10$ N
± 20 % if
 $F_t \geq 10$ N

± 30 % if
 $F_d < 21,5$ N
± 20 % if
 $F_d \geq 21,5$ N

Table 11 (continued)

Nominal diameter d_1	Radial wall thickness "regular" a_1	Ring width h_1					Closed gap s_1	Tangential force F_t N					Diametral force F_d N								
		Column						For h_1 shown in column					For h_1 shown in column								
		1	2	3	4	5		Tolerance	1	2	3	4	5	Tolerance	1	2	3	4	5	Tolerance	
130	5,25																				
131	5,30																				
132	5,30																				
133	5,35																				
134	5,40																				
135	5,40			2,5	3	3,5															
136	5,45																				
137	5,50																				
138	5,50																				
139	5,55																				
140	5,60																				
141	5,65																				
142	5,65																				
143	5,70																				
144	5,75																				
145	5,75																				
146	5,80																				
147	5,85																				
148	5,85																				
149	5,90																				
150	5,95																				
152	6,00																				
154	6,05																				
155	6,10																				
156	6,15																				
158	6,20																				

Table 11 (continued)

Dimensions in millimetres																									
Nominal diameter d_1	Radial wall thickness "regular" a_1		Ring width h_1					Closed gap s_1		Tangential force F_t N					Diametral force F_d N										
	Tolerance		Column		Tolerance			Tolerance		Tolerance		For h_1 shown in column					For h_1 shown in column								
			1	2	3	4	5			1	2	3	4	5	1	2	3	4	5	1	2	3	4	5	
160	6,25																								
162	6,35																								
164	6,40																								
165	6,40																								
166	6,45																								
168	6,50																								
170	6,60																								
172	6,65																								
174	6,70																								
175	6,75																								
176	6,80	$\pm 0,20$																							
178	6,85	Within a ring: 0,20 max.																							
180	6,90																								
182	6,95																								
184	7,05																								
185	7,05																								
186	7,10																								
188	7,15																								
190	7,20																								
192	7,25																								
194	7,35																								
195	7,35																								
196	7,40																								
198	7,45																								
200	7,50																								

NOTE 1 For intermediate sizes (for example repair sizes), the radial wall thickness of the next smaller nominal diameter should be applied.

NOTE 2 The values for F_t and F_d , given in Table 11, apply to as-cast grey cast iron with a typical modulus of elasticity (E_n) of 100 GN/m².

Multiplying factors for materials having a different modulus (E_n) are given in ISO 6621-4.

Mean forces are calculated for nominal radial wall thickness (a_1) and mean ring width (h_1).

NOTE 3 Solely for the purposes of this part of ISO 6622, the assumed average ratio F_d/F_t is 2,15. However, for rings up to 50 mm, the ratio F_d/F_t shall be determined between the manufacturer and client.

Table 12 — Dimensions of R, B, BA and M rectangular rings — Radial wall thickness “D/22” ($h \geq 5$ mm)

Nominal diameter d_1		Radial wall thickness “D/22” a_1		Ring width h_1				Closed gap s_1		Tangential force				Diametral force									
										F_t N				F_d N									
				Tolerance		Column		Tolerance		Tolerance		For h_1 shown in column				For h_1 shown in column				Tolerance			
50	2,25									7,4	8,7	9,9	12,4	15,9	18,7	21,3	26,7						
51	2,30									7,6	8,9	10,2	12,7	16,3	19,1	21,9	27,3						
52	2,35									7,8	9,1	10,4	13,1	16,8	19,6	22,4	28,2						
53	2,40									8,0	9,4	10,7	13,4	17,2	20,2	23,0	28,8						
54	2,45									8,2	9,6	11,0	13,8	17,6	20,6	23,7	29,7						
55	2,50							0,15		8,4	9,9	11,3	14,1	18,1	21,3	24,3	30,3						
56	2,55									8,6	10,1	11,5	14,5	18,5	21,7	24,7	31,2						
57	2,60									8,8	10,3	11,8	14,8	18,9	22,1	25,4	31,8						
58	2,65									9,0	10,6	12,1	15,2	19,4	22,8	26,0	32,7						
59	2,70									9,3	10,8	12,4	15,5	20,0	23,2	26,7	33,3						
60	2,75	$\pm 0,15$								9,4	11,0	12,6	15,7	20,2	23,7	27,1	33,8						
61	2,75	Within a ring: 0,15 max.								9,1	10,6	12,2	15,2	19,6	22,8	26,2	32,7						$\pm 30\%$ if $F_d < 21,5$ N
62	2,80		1,5	1,75	2	2,5				9,3	10,9	12,4	15,6	20,0	23,4	26,7	33,5						$\pm 20\%$ if $F_d \geq 21,5$ N
63	2,85									9,5	11,1	12,7	15,9	20,4	23,9	27,3	34,2						
64	2,90									9,7	11,3	13,0	16,3	20,9	24,3	28,0	35,0						
65	2,95									9,9	11,6	13,3	16,6	21,3	24,9	28,6	35,7						
66	3,00									10,1	11,8	13,5	16,9	21,7	25,4	29,0	36,3						
67	3,05									10,3	12,1	13,8	17,3	22,1	26,0	29,7	37,2						
68	3,10									10,5	12,3	14,1	17,6	22,6	26,4	30,3	37,8						
69	3,15									10,7	12,5	14,4	18,0	23,0	26,9	31,0	38,7						
70	3,20									10,9	12,8	14,6	18,3	23,4	27,5	31,4	39,3						
71	3,25									11,1	13,0	14,9	18,7	23,9	28,0	32,0	40,2						
72	3,25									10,8	12,7	14,5	18,1	23,2	27,3	31,2	38,9						
73	3,30									11,0	12,9	14,8	18,5	23,7	27,7	31,8	39,8						
74	3,35									11,2	13,1	15,0	18,8	24,1	28,2	32,3	40,4						

Table 12 (continued)

Nominal diameter d_1	Radial wall thickness "D/22" a_1	Ring width h_1				Closed gap s_1	Tangential force F_t N				Diametral force F_d N						
		Tolerance					Tolerance				Tolerance						
		1	2	3	4		1	2	3	4	1	2	3	4			
75	3,40					11,4	13,3	15,2	19,1	24,5	28,6	32,7	41,1				
76	3,45					11,6	13,6	15,5	19,4	24,9	29,2	33,3	41,7				
77	3,50					11,8	13,8	15,8	19,8	25,4	29,7	34,0	42,6				
78	3,55					12,0	14,0	16,1	20,1	25,8	30,1	34,6	43,2				
79	3,60					12,2	14,3	16,3	20,5	26,2	30,7	35,0	44,1				
80	3,65					12,4	14,5	16,6	20,8	26,7	31,2	35,7	44,7				
81	3,70					12,6	14,8	16,9	21,1	27,1	31,8	36,3	45,4				
82	3,75		1,5	1,75	2	2,5	12,8	15,0	17,2	21,5	27,5	32,3	46,2				
83	3,75						12,5	14,6	16,7	21,0	26,9	31,4	45,2				
84	3,80						12,7	14,9	17,0	21,3	27,3	32,0	45,8				
85	3,85						12,9	15,1	17,3	21,6	27,7	32,5	46,4				
86	3,90	$\pm 0,15$ Within a ring: 0,15 max.					13,1	15,3	17,6	22,0	28,2	32,9	47,3				$\pm 30\%$ if $F_d < 21,5\text{ N}$
87	3,95						13,3	15,6	17,8	22,3	28,6	33,5	47,9				$\pm 20\%$ if $F_d \geq 21,5\text{ N}$
88	4,00						13,5	15,8	18,1	22,7	29,0	34,0	48,8				
89	4,05						13,7	16,1	18,4	23,0	29,5	34,6	49,5				
90	4,10						16,2	18,6	23,2	27,9	34,8	40,0	60,0				
91	4,15						16,5	18,8	23,6	28,3	35,5	40,4	60,8				
92	4,20						16,7	19,1	23,9	28,7	35,9	41,1	61,7				
93	4,25						16,9	19,4	24,3	29,2	36,3	41,7	62,8				
94	4,25		1,75	2	2,5	3	16,6	19,0	23,7	28,5	35,7	40,9	61,3				
95	4,30						16,8	19,2	24,1	28,9	36,1	41,3	62,1				
96	4,35						17,0	19,5	24,4	29,3	36,6	41,9	63,0				
97	4,40						17,3	19,8	24,8	29,8	37,2	42,6	64,1				
98	4,45						17,5	20,1	25,1	30,2	37,6	43,2	64,9				
99	4,50						17,8	20,3	25,5	30,6	38,3	43,6	65,8				

Table 12 (continued)

		Dimensions in millimetres																	
Nominal diameter d_1	Radial wall thickness "D/22" a_1	Ring width h_1				Closed gap s_1	Tangential force F_t N				Diametral force F_d N								
		Tolerance		Column			Tolerance		For h_1 shown in column		Tolerance		For h_1 shown in column						
		1	2	3	4		1	2	3	4	1	2	3	4	1	2	3	4	
100	4,55							20,6	25,8	31,0		44,3	55,5	66,7					
101	4,60							20,8	26,1	31,3		44,7	56,1	67,3					
102	4,65							21,1	26,4	31,7		45,4	56,8	68,2					
103	4,70							21,3	26,7	32,1		45,8	57,4	69,0					
104	4,75							21,6	27,0	32,4		46,4	58,1	69,7					
105	4,75		2	2,5	3	0,3		21,1	26,4	31,8		45,4	56,8	68,4					
106	4,80							21,4	26,7	32,1		46,0	57,4	69,0					
107	4,85							21,6	27,1	32,5		46,4	58,3	69,9					
108	4,90							21,8	27,4	32,9		46,9	58,9	70,7					
109	4,95							22,1	27,7	33,2		47,5	59,6	71,4					
110	5,00							27,9	33,5	39,1		60,0	72,0	84,1					
111	5,05							28,2	33,8	39,5		60,6	72,7	84,9					
112	5,10							28,5	34,2	40,0		61,3	73,5	86,0					
113	5,15							28,8	34,6	40,4		61,9	74,4	86,9					
114	5,20							29,1	34,9	40,8		62,6	75,0	87,7					
115	5,25							29,4	35,3	41,2		63,2	75,9	88,6					
116	5,25							28,8	34,6	40,4		61,9	74,4	86,9					
117	5,30		2,5	3	3,5	0,35		29,1	35,0	40,8		62,6	75,3	87,7					
118	5,35							29,4	35,3	41,3		63,2	75,9	88,8					
119	5,40							29,7	35,7	41,7		63,9	76,8	89,7					
120	5,45							30,0	36,0	42,1		64,5	77,4	90,5					
121	5,50							30,3	36,4	42,5		65,1	78,3	91,4					
122	5,55							30,6	36,7	42,9		65,8	78,9	92,2					
123	5,60							30,9	37,1	43,3		66,4	79,8	93,1					
124	5,65							31,2	37,4	43,7		67,1	80,4	94,0					

Table 12 (continued)

Nominal diameter d_1	Radial wall thickness "D/22" a_1	Ring width h_1				Closed gap s_1	Tangential force F_t N				Diametral force F_d N						
		Tolerance					Tolerance				Tolerance						
		1	2	3	4		1	2	3	4	1	2	3	4			
125	5,70						31,4	37,8	44,1		67,5	81,3	94,8				
126	5,75				0,35		31,7	38,1	44,5		68,2	81,9	95,7				
127	5,75						31,2	37,5	43,8		67,1	80,6	94,2				
128	5,80						31,5	37,8	44,2		67,7	81,3	95,0				
129	5,85						31,8	38,2	44,6		68,4	82,1	95,9				
130	5,90						32,0	38,4	44,8		68,8	82,6	96,3				
131	5,95						32,2	38,7	45,2		69,2	83,2	97,2				
132	6,00	—	2,5	3	3,5		32,5	39,1	45,6		69,9	84,1	98,0				
133	6,05	$\pm 0,20$					32,8	39,4	46,0		70,5	84,7	98,9				$\pm 30\%$ if $F_d < 21,5\text{ N}$
134	6,10	Within a ring: 0,20 max.					33,1	39,8	46,4		71,2	85,6	99,8				$\pm 20\%$ if $F_d \geq 21,5\text{ N}$
135	6,15						33,4	40,1	46,8		71,8	86,2	100,6				
136	6,20						33,7	40,4	47,2		72,5	86,9	101,5				
137	6,25						33,9	40,8	47,6		72,9	87,7	102,3				
138	6,25						33,4	40,1	46,8		71,8	86,2	100,6				
139	6,30						33,7	40,4	47,2		72,5	86,9	101,5				
140	6,35						40,8	47,6	54,5		87,7	102,3	117,2				
141	6,40						41,1	48,0	54,9		88,4	103,2	118,0				
142	6,45		3	3,5	4		41,4	48,4	55,4		89,0	104,1	119,1				
143	6,50						41,8	48,8	55,8		89,9	104,9	120,0				
144	6,55						42,1	49,2	56,2		90,5	105,8	120,8				

Table 12 (continued)

Dimensions in millimetres

Nominal diameter d_1	Radial wall thickness "D/22" a_1	Ring width h_1				Closed gap s_1	Tangential force F_t N				Diametral force F_d N								
		Tolerance		Column			Tolerance		For h_1 shown in column		Tolerance		For h_1 shown in column		Tolerance				
145	6,60																		
146	6,65	$\pm 0,20$																	
147	6,70	Within a ring:				0,4													
148	6,75	0,20 max.																	
149	6,75																		
150	6,80																		

NOTE 1 For intermediate sizes (for example repair sizes), the radial wall thickness of the next smaller nominal diameter should be applied.

NOTE 2 The values for F_t and F_d given in Table 12 apply to as-cast grey cast iron with a typical modulus of elasticity (E_n) of 100 GN/m².

NOTE 3 Multiplying factors for materials having a different modulus (E_n) are given in ISO 6621-4. Mean forces are calculated for nominal radial wall thickness (a_1) and mean ring width (h_1). Solely for the purposes of this part of ISO 6622, the assumed average ratio F_d/F_t is 2,15.

Bibliography

- [1] ISO 1101, *Technical drawings — Geometrical tolerancing — Tolerancing of form, orientation, location and run-out — Generalities, definitions, symbols, indications on drawings*
- [2] ISO 6621-1, *Internal combustion engines — Piston rings — Part 1: Vocabulary*
- [3] ISO 6621-2, *Internal combustion engines — Piston rings — Part 2: Inspection measuring principles*
- [4] ISO 6621-3, *Internal combustion engines — Piston rings — Part 3: Material specifications*
- [5] ISO 6621-5, *Internal combustion engines — Piston rings — Part 5: Quality requirements*
- [6] ISO 6623, *Internal combustion engines — Piston rings — Scraper rings made of cast iron*
- [7] ISO 6624-1, *Internal combustion engines — Piston rings — Part 1: Keystone rings made of cast iron*
- [8] ISO 6624-2, *Internal combustion engines — Piston rings — Part 2: Half keystone rings made of cast iron*
- [9] ISO 6624-3, *Internal combustion engines — Piston rings — Part 3: Keystone rings made of steel*
- [10] ISO 6624-4, *Internal combustion engines — Piston rings — Part 4: Half keystone rings made of steel*
- [11] ISO 6625, *Internal combustion engines — Piston rings — Oil control rings*
- [12] ISO 6626, *Internal combustion engines — Piston rings — Coil-spring-loaded oil control rings*
- [13] ISO 6626-2, *Internal combustion engines — Piston rings — Part 2: Coil-spring-loaded oil control rings of narrow ring width made of cast iron*
- [14] ISO 6627, *Internal combustion engines — Piston rings — Expander/segment oil-control rings*

