Laboratory glassware — Filter flasks

Verrerie de laboratoire — Fioles à filtrer



Reference number
ISO 6556:2012(E)

© ISO 2012



COPYRIGHT PROTECTED DOCUMENT

© ISO 2012

All rights reserved. Unless otherwise specified, no part of this publication may be reproduced or utilized in any form or by any means, electronic or mechanical, including photocopying and microfilm, without permission in writing from either ISO at the address below or ISO's member body in the country of the requester.

ISO copyright office
Case postale 56 • CH-1211 Geneva 20
Tel. + 41 22 749 01 11
Fax + 41 22 749 09 47
E-mail copyright@iso.org
Web www.iso.org

Published in Switzerland

Contents

Page

Foreword	iv
1 Scope	1
2 Normative references	1
3 Series and capacities	1
4 Material	1
5 Construction	1
5.1 Pressure strength	1
5.2 Shape	1
5.3 Radius of curvature of base	2
5.4 Wall thickness	2
5.5 Neck	2
5.6 Protective coating	2
6 Series A filter flasks	2
6.1 Vacuum connection (side-arm)	2
6.2 Dimensions	4
7 Series B filter flasks	4
7.1 Vacuum connection (side-arm)	4
7.2 Dimensions	5
8 Thermal shock endurance	5
9 Inscriptions	5
Annex A (normative) Type test for pressure strength	7
Bibliography	9

Foreword

ISO (the International Organization for Standardization) is a worldwide federation of national standards bodies (ISO member bodies). The work of preparing International Standards is normally carried out through ISO technical committees. Each member body interested in a subject for which a technical committee has been established has the right to be represented on that committee. International organizations, governmental and non-governmental, in liaison with ISO, also take part in the work. ISO collaborates closely with the International Electrotechnical Commission (IEC) on all matters of electrotechnical standardization.

International Standards are drafted in accordance with the rules given in the ISO/IEC Directives, Part 2.

The main task of technical committees is to prepare International Standards. Draft International Standards adopted by the technical committees are circulated to the member bodies for voting. Publication as an International Standard requires approval by at least 75 % of the member bodies casting a vote.

Attention is drawn to the possibility that some of the elements of this document may be the subject of patent rights. ISO shall not be held responsible for identifying any or all such patent rights.

ISO 6556 was prepared by Technical Committee ISO/TC 48, *Laboratory equipment*, and by Technical Committee CEN/TC 332, *Laboratory equipment* in collaboration.

This second edition cancels and replaces the first edition (ISO 6556:1981), which has been technically revised to incorporate the following modifications.

- a) Filter flasks of cylindrical shape with capacities of 3 l to 20 l have been added.
- b) Two series of filter flasks have been introduced to meet market needs.
- c) The glass material for filter flasks has been limited to borosilicate glass 3.3.
- d) A requirement for thermal shock endurance of filter flasks has been added.
- e) The dimensions and figures have been updated to the state of manufacturing.

.....

Laboratory glassware — Filter flasks

1 Scope

This International Standard specifies requirements to filter flasks with conical or cylindrical shape for general laboratory purposes.

2 Normative references

The following referenced documents are indispensable for the application of this document. For dated references, only the edition cited applies. For undated references, the latest edition of the referenced document (including any amendments) applies.

ISO 718, *Laboratory glassware — Thermal shock and thermal shock endurance — Test methods*

ISO 3585, *Borosilicate glass 3.3 — Properties*

3 Series and capacities

Two series of filter flasks are specified.

Series A filter flasks have either

- a conical shape (see Figure 1) with nominal capacities of 100 ml, 250 ml, 500 ml, 1 000 ml and 2 000 ml, or
- a cylindrical shape (see Figure 2) with nominal capacities of 3 l, 5 l, 10 l, 15 l and 20 l.

Series B filter flasks have a conical shape and a different choice of vacuum connections compared to Series A filter flasks and have nominal capacities of 25 ml, 50 ml, 125 ml, 250 ml, 500 ml, 1 000 ml, 2 000 ml and 4 000 ml.

4 Material

Filter flasks shall be made of borosilicate glass 3.3 conforming with ISO 3585; the glass shall be reasonably free from residual strain and from glass defects which might impair safety, durability or appearance.

5 Construction

5.1 Pressure strength

Filter flasks shall be constructed so as to withstand a pressure differential (external-internal) of 2 bar (1 bar = 10^5 Pa), i.e. twice the pressure in normal use, when tested in accordance with the test method specified in Annex A.

For this purpose, the dimensions given for wall thickness and radius of curvature given in Tables 1 to 3 shall be observed.

5.2 Shape

Filter flasks shall be conical or cylindrical. The base of the flasks shall be so constructed that they stand vertically without rocking or spinning when placed on a level surface.

5.3 Radius of curvature of base

The base of the flask shall have a suitable radius of curvature in order to provide a smooth transition between the base and the side. The radius shall be not less than that given in Tables 1 to 3.

5.4 Wall thickness

The flask shall be blown so as to achieve a good distribution of glass in the mould without sudden changes in wall thickness. In order to meet the requirements of 5.1, the thinnest areas shall have a thickness not less than the minimum values specified in Tables 1 to 3.

5.5 Neck

The top of the neck shall be formed to provide suitable strength. The neck may be slightly tapered or cylindrical; alternatively, it may be manufactured with an interchangeable joint of appropriate size selected from ISO 383.

5.6 Protective coating

For protection against mechanical damage (impact or shock), filter flasks may have an external plastic coating.

6 Series A filter flasks

6.1 Vacuum connection (side-arm)

The vacuum connection shall be placed just at, or below, the cylindrical part of the neck (see Figure 1 and Figure 2). Three types of vacuum connection are described:

- a) a tubular side-arm as shown in Figure 3 with a taper of 1:5 to 1:10;
- b) an integral side-arm with a glass round thread as shown in Figure 4;
- c) a detachable side-arm; a typical arrangement with a resilient grommet is shown in Figure 5. A detachable side-arm may also be provided with an appropriate glass round thread.

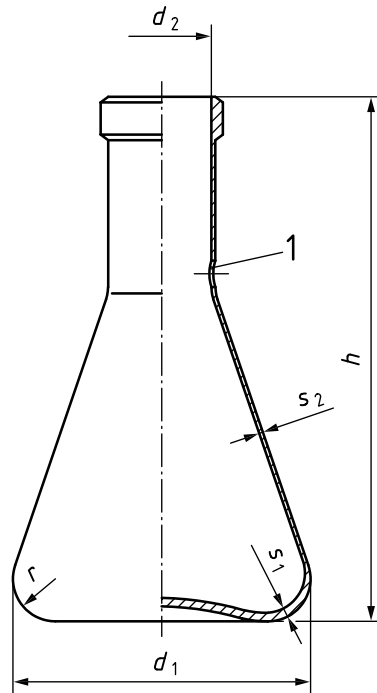

Key

1 vacuum connection

Figure 1 — Conical shape

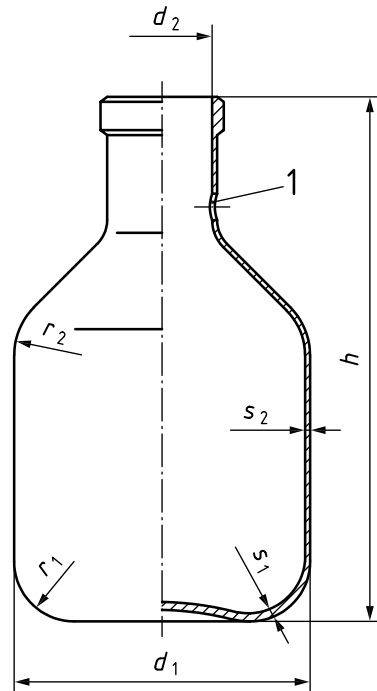

Key

1 vacuum connection

Figure 2 — Cylindrical shape

6.2 Dimensions

Series A filter flasks of conical shape shall comply with the dimensions given in Table 1. Series A filter flasks of cylindrical shape shall comply with the dimensions in Table 2.

Table 1 — Dimensions for Series A conical shapes

Dimensions in millimetres

Nominal size ml	d_1 ±3	d_2 ±1,5	h ±3	r min.	s_1 min.	s_2 min.
100	70	24	105	12	1,7	1,2
250	85	35	155	12	2,4	1,3
500	105	35	185	15	3	1,4
1 000	135	45	230	20	3,8	1,6
2 000	165	60	255	35	4,2	1,8

Table 2 — Dimensions for Series A cylindrical shapes

Dimensions in millimetres

Nominal size l	d_1 ±5	d_2 ±1,5	h ±5	r_1 ≈	r_2 ≈	s_1 min.	s_2 min.
3	170	70	295	28	40	4,7	4
5	185	80	360	30	48	5,1	4
10	237	80	420	48	54	6,4	4
15	257	85	500	48	58	7,0	4
20	287	85	535	60	79	7,7	4

7 Series B filter flasks

7.1 Vacuum connection (side-arm)

The vacuum connection shall be placed near the neck-to-body junction, and sufficiently below the top of the neck that a potential blockage of the vacuum inlet by neck closures is avoided.

The following types of vacuum connection are described:

- a) plain, without provision for direct connection to vacuum tubing;
- b) with integral side-arm:
 - 1) tubular side-arm with corrugated outside surface for interfacing with the inside of vacuum tubing;
 - 2) tubular side-arm with tapered cone for interfacing with the outside of vacuum tubing;
 - 3) tubular side-arm with glass round thread for interfacing with a matching connector;
- c) with replaceable side-arm of glass or plastic material:
 - 1) straight;
 - 2) angled;
 - 3) multiple replaceable side-arms.

7.2 Dimensions

Series B filter flasks shall comply with the dimensions given in Table 3.

Table 3 — Dimensions for Series B filter flasks

Dimensions in millimetres

Nominal size ml	d_1 max.	h max.	r min.	s_1 min.
25	41	77	6	1,0
50	52	85	6	1,5
125	71	115	12	1,5
250	86	160	12	1,8
500	108	190	15	2,0
1 000	138	245	20	2,0
2 000	170	305	23	2,5
4 000	210	385	26	3,0

8 Thermal shock endurance

Filter flasks shall be type tested to comply with a thermal shock endurance of 75 °C in accordance with ISO 718.

9 Inscriptions

The following inscriptions shall be permanently and legibly marked on all filter flasks:

- the nominal capacity of the flask, for example “100 ml”;
- the maker’s and/or vendor’s name or mark;
- the type of glass from which the flask is made, if not identified by the maker’s name or mark.

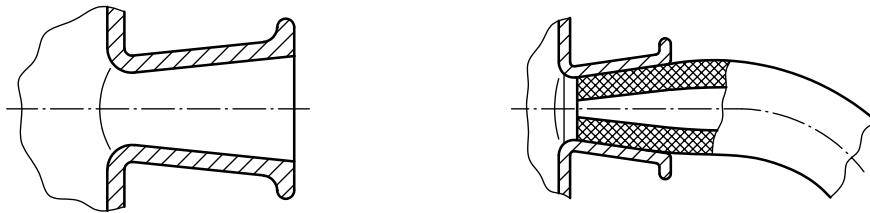

Figure 3 — Tubular side-arm and inserted vacuum rubber tube

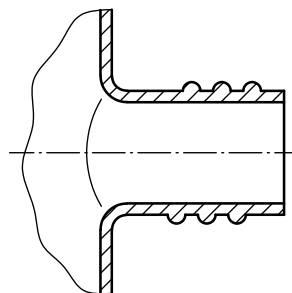

Figure 4 — Integral side-arm with glass round thread

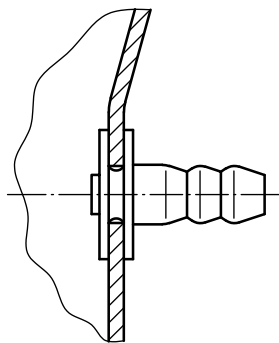

Figure 5 — Detachable side-arm

Annex A (normative)

Type test for pressure strength

A.1 General

The filter flask is tested in a pressure vessel by subjecting it to a hydraulic external pressure of 2 bar for 1 min.

A.2 Apparatus

A.2.1 Pressure vessel, provided with a pressure gauge and connected to a water reservoir fitted with a ram pump and a release valve discharging back into the reservoir. The lid of the pressure vessel can be fastened to the vessel by means of wing-nuts for ease of operation.

The recommended apparatus is illustrated in Figure A.1.

A.3 Procedure

Close the filter flask by appropriate means, for example stoppers, the interior of the filter flask being under atmospheric pressure (about 1 bar). To ensure submersion, hold the filter flask in the pressure vessel in some holding device; alternatively, place weights wrapped in paper or cloth inside it. Having placed the filter flask in position and fastened the lid, fill the pressure vessel with water and bring up the gauge pressure to 2 bar by working the ram pump and release it immediately after 1 min.

A.4 Result

The filter flask shall be taken to have satisfied the requirement of the test if it withstands the hydraulic external pressure of 2 bar for 1 min.

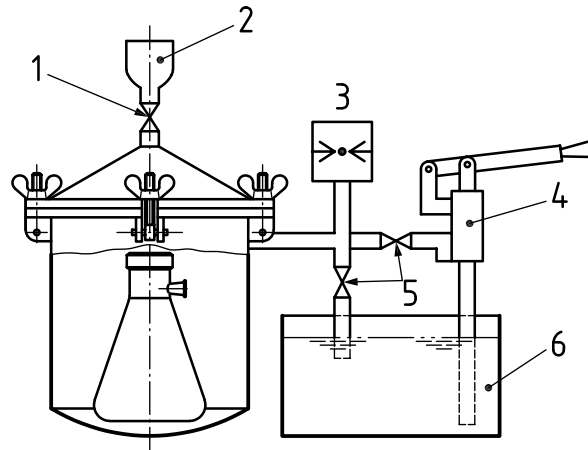

Key

- 1 pressure relief valve
- 2 funnel
- 3 pressure gauge
- 4 pump
- 5 valves
- 6 reservoir

Figure A.1 — Test rig for pressure strength

Bibliography

- [1] ISO 383, *Laboratory glassware — Interchangeable conical ground joints*

www.iso.org

ICS 71.040.20

Price based on 9 pages