

INTERNATIONAL
STANDARD

ISO
6518-2

Second edition
1995-04-01

Road vehicles — Ignition systems —

Part 2:

Electrical performance and function test
methods

Véhicules routiers — Systèmes d'allumage —

*Partie 2: Performances électriques et méthodes d'essai de
fonctionnement*



Reference number
ISO 6518-2:1995(E)

Foreword

ISO (the International Organization for Standardization) is a worldwide federation of national standards bodies (ISO member bodies). The work of preparing International Standards is normally carried out through ISO technical committees. Each member body interested in a subject for which a technical committee has been established has the right to be represented on that committee. International organizations, governmental and non-governmental, in liaison with ISO, also take part in the work. ISO collaborates closely with the International Electrotechnical Commission (IEC) on all matters of electrotechnical standardization.

Draft International Standards adopted by the technical committees are circulated to the member bodies for voting. Publication as an International Standard requires approval by at least 75 % of the member bodies casting a vote.

International Standard ISO 6518-2 was prepared by Technical Committee ISO/TC 22, *Road vehicles*, Subcommittee SC 1, *Ignition equipment*.

This second edition cancels and replaces the first edition (ISO 6518-2:1982), which has been changed as follows:

- introduction of test methods A (spark gaps) and B (Zener diode string);
- detailed revision of the clauses on test equipment, measured parameters and test procedures.

ISO 6518 consists of the following parts, under the general title *Road vehicles — Ignition systems*:

- *Part 1: Vocabulary*
- *Part 2: Electrical performance and function test methods*

© ISO 1995

All rights reserved. Unless otherwise specified, no part of this publication may be reproduced or utilized in any form or by any means, electronic or mechanical, including photocopying and microfilm, without permission in writing from the publisher.

International Organization for Standardization
Case Postale 56 • CH-1211 Genève 20 • Switzerland

Printed in Switzerland

Road vehicles — Ignition systems —

Part 2:

Electrical performance and function test methods

1 Scope

This part of ISO 6518 specifies the methods and test conditions for testing battery-supplied ignition systems for spark-ignited internal combustion engines.

Because of the difficulties in producing repeatable measurements with atmospheric spark gaps and different observers, two methods of obtaining the results necessary for calculating the system output energy are given.

Method A — using spark gaps for the energy measurement (test arrangement A).

The output energy obtained by this method is called spark energy, E_{sp} .

Method B — using a Zener diode string for the energy measurement (test arrangement B).

The output energy obtained by this method is called Zener discharge energy, E_{zd} .

This method is not suitable for systems giving alternating spark current.

Method B is also recommended for the comparative testing of ignition coils and current interruption systems.

2 Ignition system description

For the tests described in the following subclauses, the ignition system components used shall be as specified for the application being examined, i.e. to the original equipment specification.

2.1 Ignition system with mechanical distributor

The following components shall be interconnected as shown in figure 1 or in any other circuit which has been proved to be equivalent.

2.1.1 Single-ended coil which can be the conventional induction coil or an air or magnetic core transformer.

2.1.2 Coil ballast resistor or resistors, if the coil being tested requires a ballast resistor, or any fixed or variable means to make the voltage and/or the current in the ignition circuit vary.

2.1.3 Distributor which distributes the ignition impulses to the spark-plugs. It may also contain means of triggering and/or timing adjustment, all of which have a proper angular interrelationship to themselves and to the engine.

2.1.4 Auxiliary switching device implicit with the system being tested such as a transistorized control unit.

2.2 Static (distributorless) ignition system with single-ended coils

The following components shall be interconnected as shown in figure 2 or in any other circuit which has been proved to be equivalent.

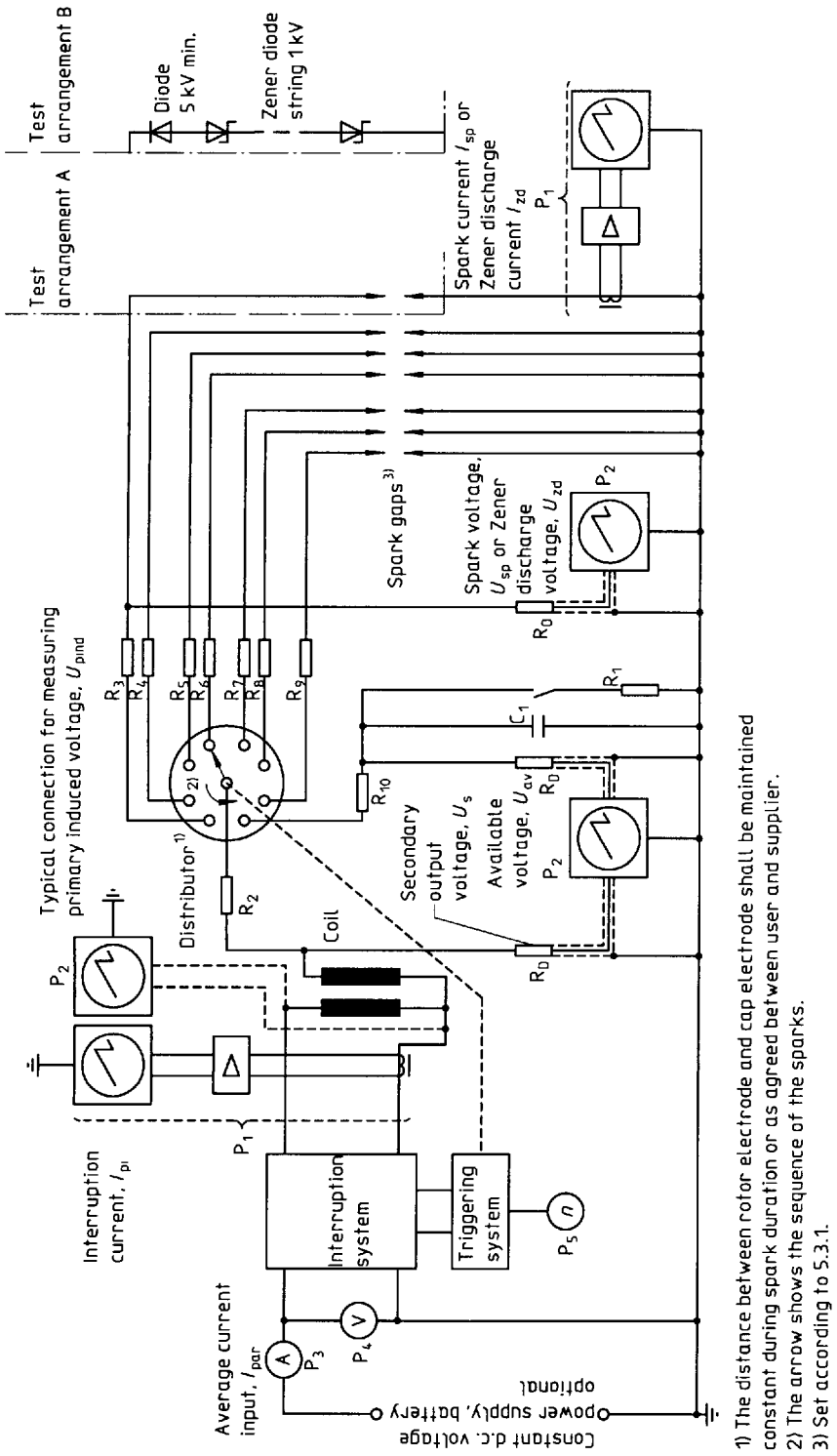

1) The distance between rotor electrode and cap electrode shall be maintained constant during spark duration or as agreed between user and supplier.
 2) The arrow shows the sequence of the sparks.
 3) Set according to 5.3.1.

Key

- P₁ = current probe, amplifier and oscilloscope
- P₂ = voltage-measuring oscilloscope
- P₃ = d.c. ammeter
- P₄ = d.c. voltmeter
- P₅ = tachometer

- C₁ = load capacity
- R₁ = load resistor
- R₂ to R₁₀ = suppression impedances (the current and resistance of which are fixed by agreement between the manufacturer and the user)
- R_D = voltage probe

NOTE — An example of an eight-cylinder system is shown

Figure 1 — Test circuit for ignition systems with mechanical distributor

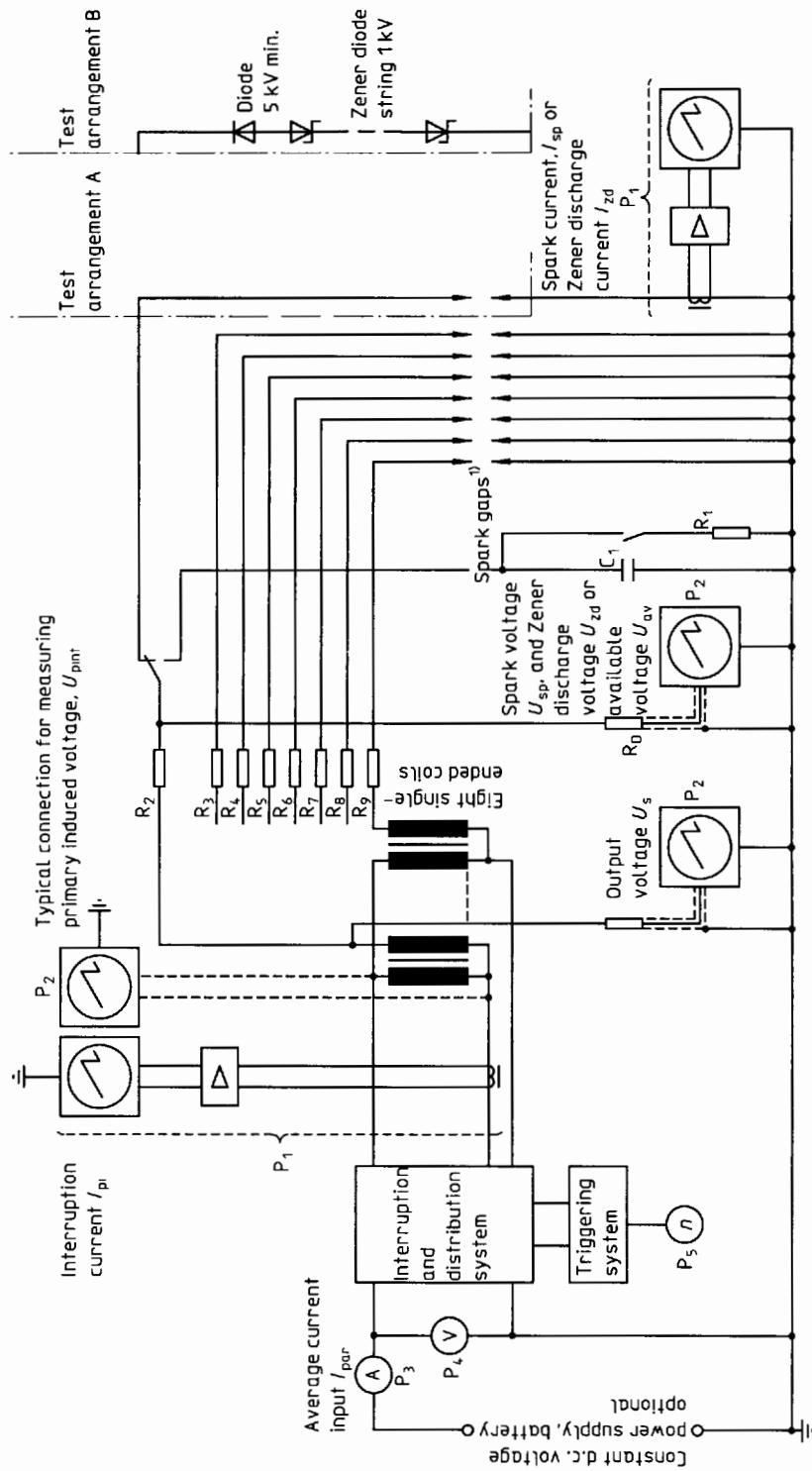

Key

- P₁ = current probe, amplifier and oscilloscope
 - P₂ = voltage-measuring oscilloscope
 - P₃ = d.c. ammeter
 - P₄ = d.c. voltmeter
 - P₅ = tachometer (crankshaft rotational frequency signal)
- NOTE — An example of an eight-cylinder system is shown

- C₁ = load capacity
- R₁ = load resistor
- R₂ to R₉ = suppression impedances (the current and resistance of which are fixed by agreement between the manufacturer and the user)
- R₀ = voltage probe

Figure 2 — Test circuit for static ignition systems with single-ended coils

2.2.1 Coils which, depending on the system tested, may be

- single-ended coils as described in 2.1.1, or
- a multiple high-tension terminal assembly formed by single-ended coils, or
- plug-top coils.

2.2.2 Auxiliary switching device implicit with the system being tested such as a transistorized control unit.

2.3 Static (distributorless) ignition system with double-ended coil(s)

The following components shall be interconnected as shown in figure 3 or in any other circuit which has been proved to be equivalent.

2.3.1 Coils which, depending on the system tested, may be

- double-ended coils, or
- a multiple high-tension terminal assembly formed by double-ended coils.

2.3.2 Auxiliary switching device implicit with the system being tested such as a transistorized control unit.

3 Test equipment

3.1 Variable d.c. power supply having a 10 % to 90 % transient recovery time of not more than 50 μ s over the load range encountered in use. It shall have no more than 50 mV variation in average voltage from no-load to full ignition system load and no more than 100 mV peak-to-peak ripple over the same load range. This power supply may be substituted by a battery with or without a charging system. The power supply shall be positioned immediately adjacent to the system being tested.

3.2 Oscilloscope with a maximum rise time of 35 ns, with a minimum band pass of 10 MHz, shall be used (P_1 and P_2). The overall uncertainty of measurement including voltage and current probes (see 3.3 and 3.4) shall be less than 3 %.

3.3 Voltage probe (R_D) with an input capacitance smaller than or equal to 5 pF and an input resistance of 100 M Ω or greater.

3.4 Current probe (P_1) suitable for d.c. to 10 MHz.

3.5 d.c. ammeter (P_3) with a maximum voltage drop of 100 mV under test conditions.

3.6 Voltmeter (P_4) with an input resistance of at least 10 k Ω /V and with sufficient resolution to indicate differences of 10 mV easily.

3.7 Distributor or trigger wheel drive stand and attached **tachometer** (P_5) conforming to the following:

- a) a continuously variable rotational frequency adjustment, capable of being varied between 10 min^{-1} and 4 000 min^{-1} for a distributor drive stand and between 20 min^{-1} and at least 6 000 min^{-1} for a trigger wheel drive stand;
- b) the rotational frequency shall be within ± 5 % below 400 min^{-1} and ± 20 min^{-1} above 400 min^{-1} ;
- c) a tachometer accurate to within $\pm 0,2$ % of indicated rotational frequency.

3.8 Loads shall be connected to the ignition system by high-voltage, non-resistive metal conductor ignition cables. The length depends on the capacitive load (see 3.8.2).

3.8.1 Multi-point spark gap stand, each gap being individually variable (see figure 5).

3.8.2 The **capacitance** C_1 simulates the capacitance of the cables and spark-plugs as normally encountered on the engine. This capacitance shall be a low dissipation factor (not greater than 3 % at 1 kHz) secondary ignition cable of a length such that, in conjunction with the capacitor and high-tension probe, the total capacitance is

50 pF to 55 pF for ignition systems with distributor;

25 pF to 30 pF for static ignition system with single-ended coils;

50 pF to 55 pF for static ignition systems with double-ended coils.

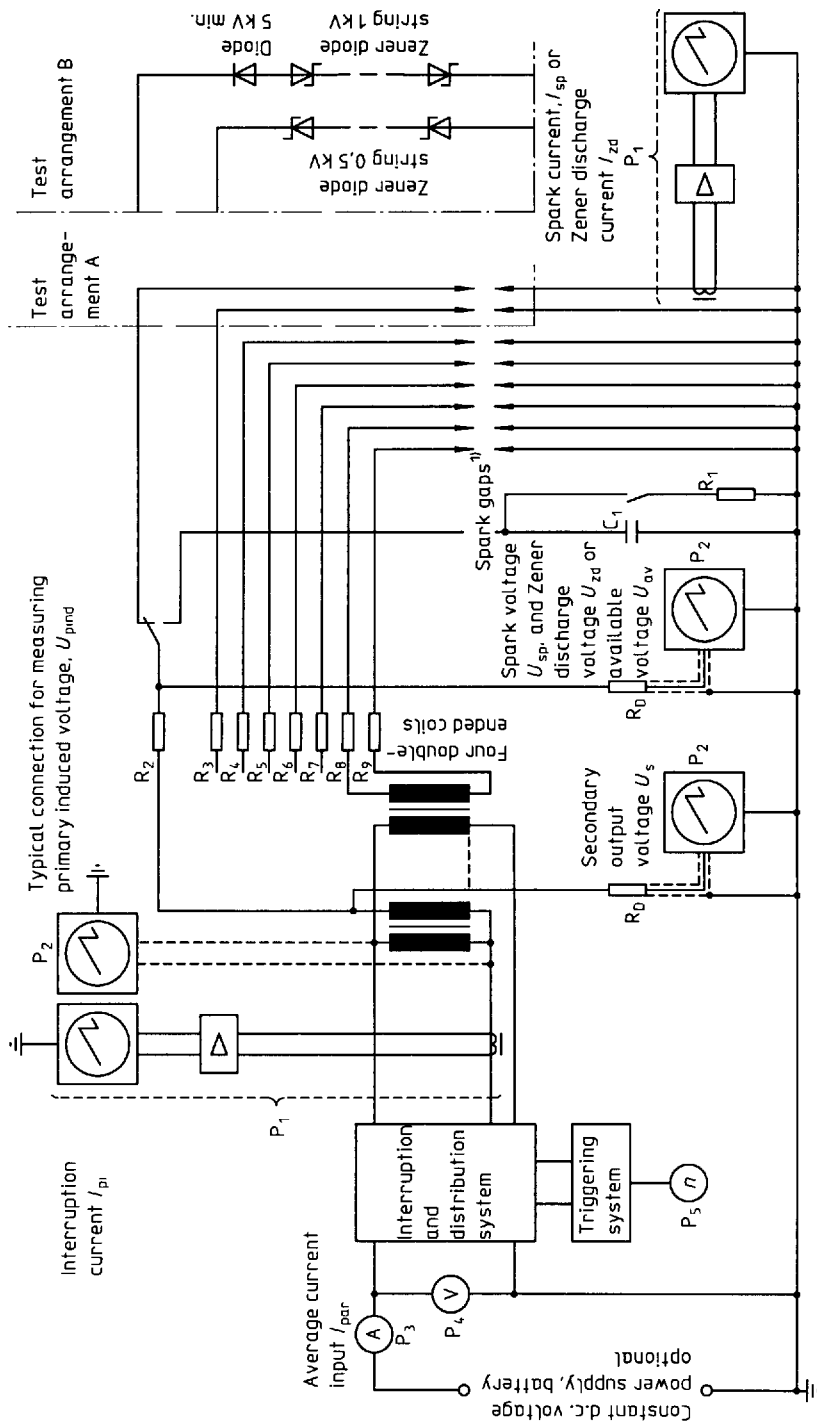

1) Set according to 5.3.1.

Key

- P₁ = current probe, amplifier and oscilloscope
- P₂ = voltage-measuring oscilloscope
- P₃ = d.c. ammeter
- P₄ = d.c. voltmeter
- P₅ = tachometer (crankshaft rotational frequency signal)

- C₁ = load capacity
- R₁ = load resistor
- R₂ to R₉ = suppression impedances (the current and resistance of which are fixed by agreement between the manufacturer and the user)
- R₀ = voltage probe

NOTES

- 1 For double-ended coils, secondary outlets shall be tested at high voltage.
- 2 An example of an eight-cylinder system is shown

Figure 3 — Test circuit for static ignition systems with double-ended coils

To measure the total capacitance, the distributor spark gaps, and the impedances R_2 to R_{10} if lumped resistors, shall be shunted and the ignition cable shall be removed from the ignition coil.

NOTES

1 It may be necessary to consider the effect of parasitic capacitances.

2 Other values of capacitance may be agreed upon depending on the application.

3.8.3 The **resistor** R_1 simulates lead or carbon fouled spark-plugs. This resistor shall have a low voltage coefficient (maximum 0,000 5 %/V), non-inductive, approximately 10 W and $1 M\Omega \pm 5 \%$. It shall be connected in parallel to the capacitance for some measurements.

3.8.4 A **Zener diode string** of 1 kV for single-ended coils and **two Zener diode strings** of 1 kV and 0,5 kV for double-ended coils (see figure 3), each with a Zener voltage tolerance of $\pm 5 \%$ under test conditions.

4 Parameters to be measured or determined

4.1 Available voltage, U_{av}

Comparing the available voltage, U_{av} , to the voltage required, U_{spc} , to fire spark-plugs in a given engine determine the adequacy of the ignition system [see figure 4 a)]. It shall be measured when the system is loaded with the capacitance C_1 described in 3.8.2.

4.2 Minimum available voltage, U_{avm}

The minimum available voltage¹⁾, U_{avm} , shall be measured when the system is loaded with the capacitance C_1 and the resistor R_1 connected in parallel. The minimum amplitude shall be recorded. This represents the level which can be guaranteed from the system being tested at an ambient temperature of $23 \text{ }^\circ\text{C} \pm 5 \text{ }^\circ\text{C}$, a trigger wheel rotational frequency of $2\ 000 \text{ min}^{-1}$ and a supply voltage of 13,5 V.

4.3 Secondary output voltage, U_s

The secondary output voltage, U_s , may also be measured for comparison with values obtained for available voltage, U_{av} .

4.4 Interruption current, I_{pi}

The interruption current¹⁾, I_{pi} , determines the energy into the system [see figure 4 c)].

4.5 Average current input, I_{par}

The average current input, I_{par} , determines the average current draw of the system with respect to the d.c. source (alternator, generator, battery, etc.).

4.6 Energy

4.6.1 Inductive spark energy, E_{spi}

The inductive spark energy²⁾, E_{spi} , is determined by test method A (see 5.3.1). It is calculated from the integration of the product of the measured values of spark voltage, U_{sp} [adjusted to U_e : see figure 4 f)] and spark current I_{sp} over the spark duration t_{fsp} [see figure 4 f)].

$$E_{spi} = \int_{t_e}^{t_i} U_{sp} \times I_{sp} dt_{fsp}$$

4.6.2 Zener discharge energy, E_{zd}

The Zener discharge energy, E_{zd} , is determined by test method B. It is calculated from the integration of the measured values of the product of Zener discharge voltage U_{zd} and Zener discharge current I_{zd} over the Zener discharge duration t_{zsd} [see figure 4 g)].

$$E_{zd} = \int_{t_e}^{t_i} U_{zd} \times I_{zd} dt_{zsd}$$

4.6.3 Spark duration or Zener discharge duration

This duration within limits is indicative of the igniting capability of the ignition coil output under marginal fuel conditions²⁾ [see figures 4 d), f) and g)].

1) This measurement does not apply to capacitor discharge ignition systems.

2) This is an indication of the amount of electrically caused erosion which will occur on spark-plug electrodes. Experience is required to use this information effectively.

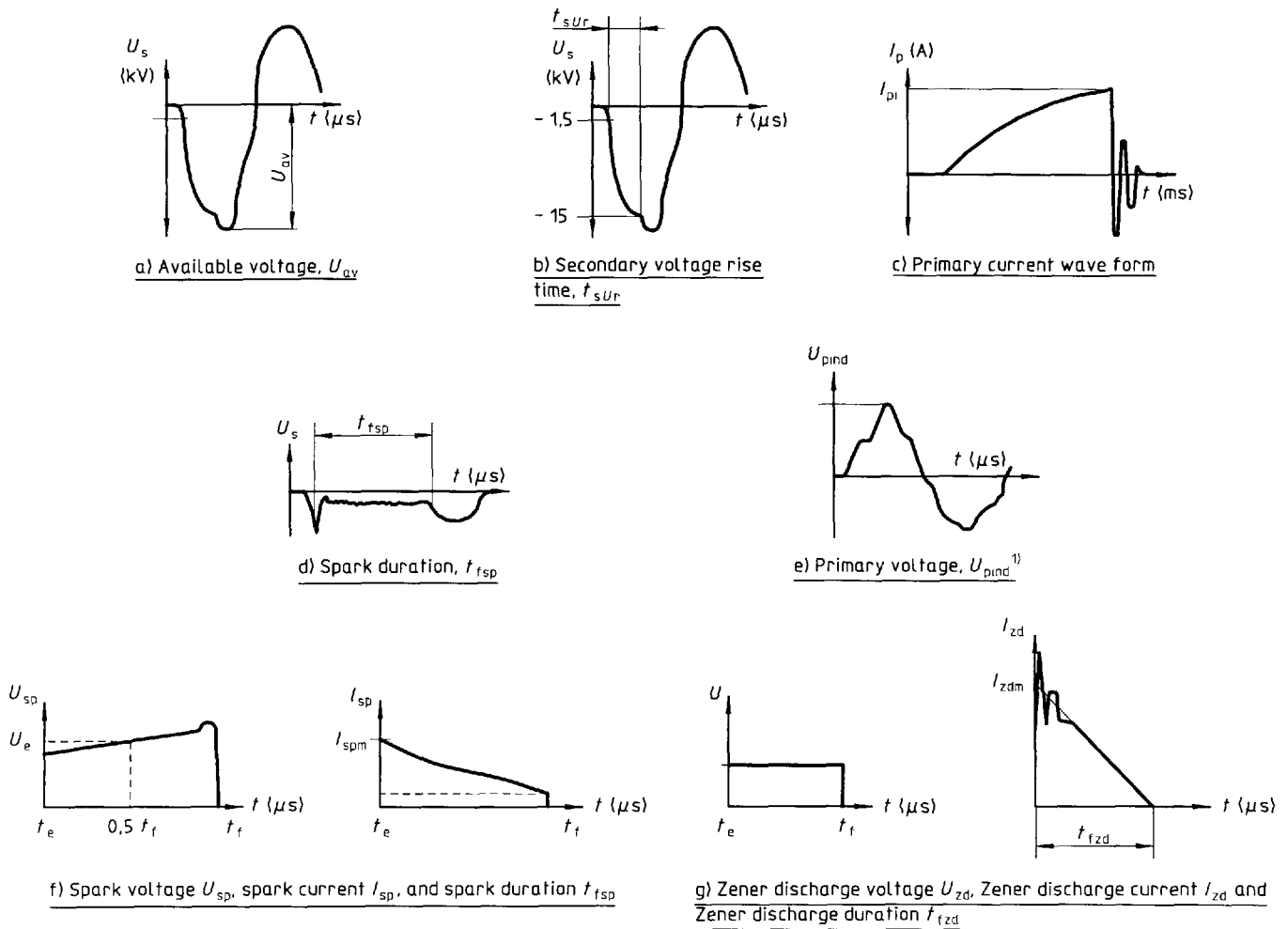

1) The wave form shown occurs in ignition systems with contact breaker.

Figure 4 — Examples of measurements performed on ignition systems

4.6.4 Maximum spark current, I_{spm} , or maximum Zener discharge current, I_{zdm}

The maximum spark current¹⁾, I_{spm} , or maximum Zener discharge current is the instantaneous current from the secondary winding of the ignition coil flowing through the spark gap after breakdown²⁾ [see figure 4 f)] or through the Zener diodes [see figure 4 g)].

4.7 Secondary voltage rise time, t_{sUr}

The secondary voltage rise time, t_{sUr} , is an indication of the ability of an ignition system to fire shunted (fouled) spark-plugs. The shorter the secondary voltage rise time, the less system energy is lost across the fouled shunt and more voltage is available to fire the spark-plug [see figure 4 b)].

It shall be measured when the system is loaded with the capacitance C_1 described in 3.8.2 and the resistor R_1 described in 3.8.3.

To facilitate comparison between systems, the secondary voltage rise time shall be determined between -1,5 kV and -15 kV, to be repeated between +1,5 kV and +15 kV for double-ended coils or as agreed between user and manufacturer.

4.8 Coil primary induced voltage, U_{pind}

The coil primary induced voltage¹⁾, U_{pind} , is useful with respect to contact breaker life in classic ignition systems and is an indication of the stress on a semiconductor power switch (unless voltage clamping is used) in inductive energy storage ignition systems [see figure 4 e)]. If it shall be measured, it may be necessary

to use a measuring instrument with a differential input.

The primary induced voltage wave form is always preceded (usually within 20 μ s) by a leakage induction spike. Usually this is ignored in calculations but if the area under the spike curve becomes significant then it is essential that it be taken into account, when considering the effect on solid state components.

4.9 Ignition-limiting load resistance, $R_{15\text{ kV}}$

The shunt behaviour of an ignition system is also determined by its ignition-limiting load resistance, $R_{15\text{ kV}}$. It is the load resistance at which the absolute value of the available voltage, U_{av} , falls to 15 kV. The designation for it is $R_{15\text{ kV}}$ (see R_1 in figures 1 to 3).

The parameters are

C_{load} (see C_1 in figures 1 to 3) as described in 3.8.2;

$U_{supply} = 13,5\text{ V}$;

$n_{crankshaft} = 2\ 000\ \text{min}^{-1}$.

5 Procedures

5.1 General

The circuit arrangements shown in figures 1 to 3 with instrumentation in place can be used to measure the parameters in clause 4.

Test arrangement A is intended for tests to confirm the required system functions and system performance.

Test arrangement B is intended for tests to compare the performance of ignition coils and current interruption systems.

5.2 Test conditions

The test conditions shall be chosen from table 1 as appropriate.

During simulated starting tests, the system shall be operated under conditions simulating vehicle electrical conditions for the primary side of the system. For example, if a resistor in series with the primary coil is normally shunted during engine cranking, this resistor shall be shunted for this portion of bench tests.

5.2.1 Supply voltage, U_{sup}

The supply voltages, U_{sup} , given in table 1, are based on 12 V nominal voltage. If 24 V systems are to be tested, multiply these voltages by two.

Table 1 — Test conditions

Trigger wheel rotational frequency ¹⁾ min^{-1}	Supply voltage U_{sup} $\pm 0,1$ V	Ambient temperature °C				Operating condition
		Test at room temperature	Test at operational temperature			
			Temperature class			
			I ²⁾	II ³⁾	III ³⁾	
40	6	+ 23 \pm 5	- 30 \pm 3			Cold starting
100	10	+ 23 \pm 5	+ 80 \pm 2	+ 100 \pm 2	+ 120 \pm 2	Warm starting
500 1 000 2 000 3 000 4 000 5 000 6 000 7 000 8 000	13,5	+ 23 \pm 5	+ 80 \pm 2	+ 100 \pm 2	+ 120 \pm 2	Running

1) For the distributor rotational frequency, divide by two.
 2) Class I is preferred for items mounted in vehicle cabin or similar environment
 3) Class II or III is preferred for items mounted on or near the engine.

5.2.2 Ambient temperatures

Allow the ignition system to soak at least 1 h at the temperatures listed in table 1 before beginning tests.

Before any readings are recorded at any of the test points, the system shall be allowed to come to a thermally stable operating condition to be agreed upon between manufacturer and user.

When environmental equipment is used to control ambient temperature, care shall be taken that wire and/or cable lengths and, consequently, impedances do not distort test results.

5.3 Test methods

Test methods A and B differ in the test arrangement for the energy measurement (spark voltage or Zener discharge voltage, spark current or Zener discharge current, and spark duration or Zener discharge duration).

The resulting energies calculated will differ.

5.3.1 Test method A — Inductive spark energy

Test method A is closest to a vehicle installation and shall be used with test arrangement A to confirm the system functions. It shall be used to measure the parameters in clause 4 under the conditions given in 5.2 and the appropriate condition in table 1.

The calculation in 4.6.1 with this procedure determines the inductive part of the spark energy dis-

charged in a spark gap as shown in figures 5 and 6. The spark gap for single-ended coils shall be set to give a spark voltage U_{sp} of $1 \text{ kV} \pm 5\%$. For double-ended coils (see figure 3), two spark gaps shall be used, one set to $1 \text{ kV} \pm 5\%$, the other to $0,5 \text{ kV} \pm 5\%$ for each secondary winding.

The oscilloscope P_2 (see 3.2) and the voltage probe R_D (see 3.3) shall be used to measure the spark voltage and the spark duration. The voltage probe shall be connected to a spark gap that has been adjusted to a value U_{sp} . To measure the spark current, a current probe shall be used as shown in figures 1 to 3, test arrangement A.

5.3.2 Test method B — Zener discharge energy

Test method B shall be used with test arrangement B to compare the performance and function of ignition coils and current interruption systems.

For the energy measurement, a Zener diode string of 1 kV as shown in figures 1 and 2, test arrangement B, or one Zener diode string of 1 kV and one Zener diode string of 0,5 kV as shown in figure 3 shall be used. The discharge current used for the energy calculation shall be measured by using a current probe as shown in figures 1 to 3, test arrangement B.

The energy calculation is given in 4.6.2.

The oscilloscope P_2 and the voltage R_D are used as shown in figures 1 to 3 to measure the voltage across the Zener diode string and the discharge duration.

Dimensions in millimetres

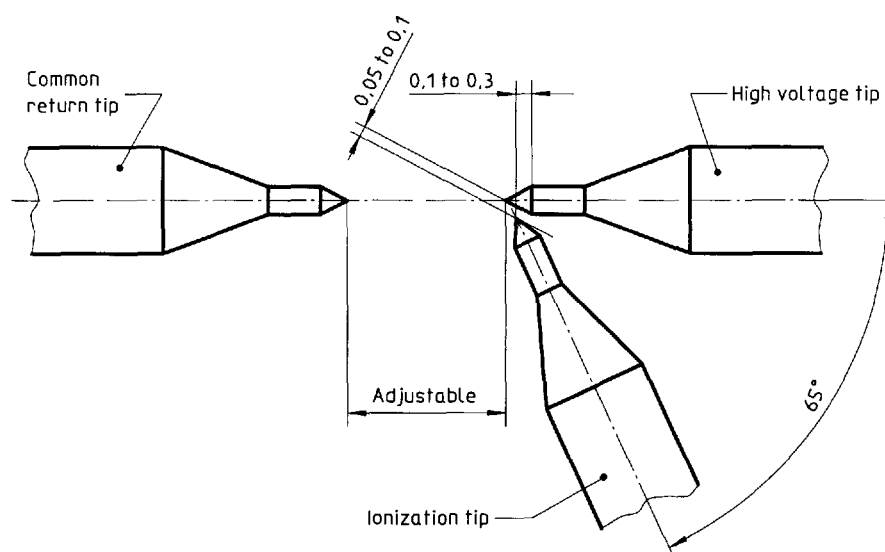

Figure 5 — Setting of pointed spark gap

Dimensions in millimetres

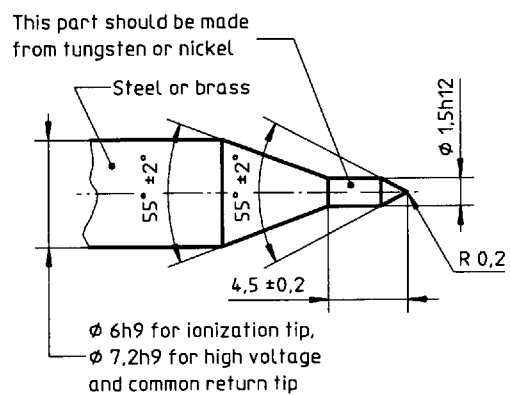

Figure 6 — Spark gap electrode requirements

ICS 43.060.50

Descriptors: road vehicles, motor vehicles, internal combustion engines, controlled ignition engines, ignition systems, tests, performance tests, testing conditions

Price based on 10 pages
