**Agricultural vehicles — Mechanical
connections between towed and towing
vehicles —**

Part 5:
**Specifications for non-swivel clevis
couplings**

*Véhicules agricoles — Liaisons mécaniques entre véhicules
remorqueurs et véhicules remorqués —*

Partie 5: Spécifications pour attelages de type chape non rotatifs





COPYRIGHT PROTECTED DOCUMENT

© ISO 2011

All rights reserved. Unless otherwise specified, no part of this publication may be reproduced or utilized in any form or by any means, electronic or mechanical, including photocopying and microfilm, without permission in writing from either ISO at the address below or ISO's member body in the country of the requester.

ISO copyright office
Case postale 56 • CH-1211 Geneva 20
Tel. + 41 22 749 01 11
Fax + 41 22 749 09 47
E-mail copyright@iso.org
Web www.iso.org

Published in Switzerland

Foreword

ISO (the International Organization for Standardization) is a worldwide federation of national standards bodies (ISO member bodies). The work of preparing International Standards is normally carried out through ISO technical committees. Each member body interested in a subject for which a technical committee has been established has the right to be represented on that committee. International organizations, governmental and non-governmental, in liaison with ISO, also take part in the work. ISO collaborates closely with the International Electrotechnical Commission (IEC) on all matters of electrotechnical standardization.

International Standards are drafted in accordance with the rules given in the ISO/IEC Directives, Part 2.

The main task of technical committees is to prepare International Standards. Draft International Standards adopted by the technical committees are circulated to the member bodies for voting. Publication as an International Standard requires approval by at least 75 % of the member bodies casting a vote.

Attention is drawn to the possibility that some of the elements of this document may be the subject of patent rights. ISO shall not be held responsible for identifying any or all such patent rights.

ISO 6489-5 was prepared by Technical Committee ISO/TC 23, *Tractors and machinery for agriculture and forestry*, Subcommittee SC 4, *Tractors*.

ISO 6489 consists of the following parts, under the general title *Agricultural vehicles — Mechanical connections between towed and towing vehicles*:

- *Part 1: Dimensions of hitch-hooks*
- *Part 2: Specifications for clevis coupling 40*
- *Part 3: Tractor drawbar*
- *Part 4: Dimensions of piton-type coupling*
- *Part 5: Specifications for non-swivel clevis couplings*

.....

Agricultural vehicles — Mechanical connections between towed and towing vehicles —

Part 5: Specifications for non-swivel clevis couplings

1 Scope

This part of ISO 6489 specifies the requirements for non-swivel clevis couplings used for the attachment of agricultural trailers and implements equipped with a swivel hitch ring as specified in ISO 5692-3 to the rear of self-propelled agricultural vehicles.

2 Normative references

The following referenced documents are indispensable for the application of this document. For dated references, only the edition cited applies. For undated references, the latest edition of the referenced document (including any amendments) applies.

ISO 286-1:1988, *ISO system of limits and fits — Part 1: Bases of tolerances, deviations and fits*

ISO 2768-1:1989, *General tolerances — Part 1: Tolerances for linear and angular dimensions without individual tolerance indications*

ISO 5692-3:2011, *Agricultural vehicles — Mechanical connections on towed vehicles — Part 3: Swivel hitch rings*

3 Terms and definitions

For the purposes of this document, the following terms and definitions apply.

3.1

non-swivel clevis coupling

hitching device, not rotating around the horizontal longitudinal axis (roll), for the mechanical connection of trailers and implements

3.2

coupling reference centre

point along the pin centreline crossing the horizontal symmetry centreline of the drawbar housing

3.3

D value

D

mathematically established representative force for the horizontal component of the force acting on the coupling in the longitudinal axis of the machine

NOTE It is expressed in kilonewtons (kN).

3.4 vertical load on the coupling point

S
load transmitted, under static conditions, on the reference centre of the mechanical coupling

NOTE It is expressed in kilograms (kg).

4 Constructional requirements

Constructional requirements not given in this part of ISO 6489 shall be specified as appropriate. Tolerances on dimensions without individual tolerance indications shall be in accordance with ISO 2768-1:1989, tolerance class c. Limits and fits shall be in accordance with ISO 286-1.

The dimensions of trailer or implement couplings of shapes w, x, y and z shall be in accordance with Figure 1 and Table 1.

5 Calculation of D value

The D value shall be calculated, in kilonewtons, using the following equation, where the values of m_r and m_t are known:

$$D = g \times \left(\frac{m_t \times m_r}{m_t + m_r} \right)$$

where

- g is the acceleration due to gravity, 9,81 m/s²;
- m_r is the allowable mass of the trailer or towed implement, in tonnes;
- m_t is the allowable total mass of the tractor or towing vehicle, in tonnes.

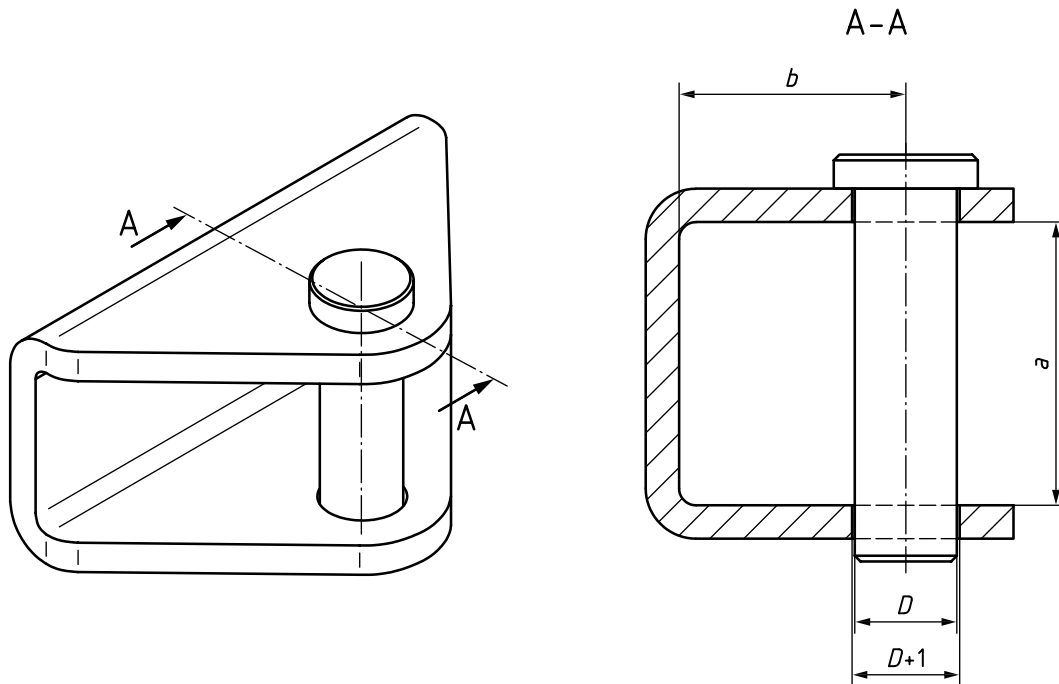

NOTE Dimensions are given in Table 1.

Figure 1 — Non-swivel clevis coupling

Table 1 — Shapes and dimensions of trailer or implement clevis couplings

Vertical load <i>S</i> kg	D value <i>D</i> kN	Shape	Dimension mm		
			<i>D</i> ±0,5	<i>a</i> min.	<i>b</i> min.
≤1 000	≤35	w	18	50	40
≤2 000	≤90	x	28	70	55
≤3 000	≤120	y	43	100	80
≤3 000	≤120	z	50	110	95

6 Design requirements

6.1 The coupling unit shape shall allow the swivel hitch ring the following minimum angles:

- ± 60° in the horizontal plane (yaw),
- ± 20° in the vertical plane (pitch),
- ± 20° around its longitudinal axis (roll).

6.2 Where a sub-frame is used between the agricultural tractor or towing vehicle and the coupling, this shall be tested with the appropriate coupling, according to the maximum coupling capacity.

6.3 The non-swivel clevis coupling unit shall be provided with a device to prevent unintentional uncoupling. This device shall be

- easy to apply,
- retained on the hitch unit, and
- tested by the application of a static load of 0,25 *D*.

6.4 The clevis shall be designed for the *D* values specified in Table 1.

7 Location

7.1 Horizontal location

The non-swivel clevis coupling shall be located as shown in Figure 2, mounted in the plane of the tractor's or towing vehicle's longitudinal axis. The centre of the non-swivel clevis coupling shall be located at the distance, *t*, rearwards from the end of the power take-off (PTO) shaft, in accordance with Table 2.

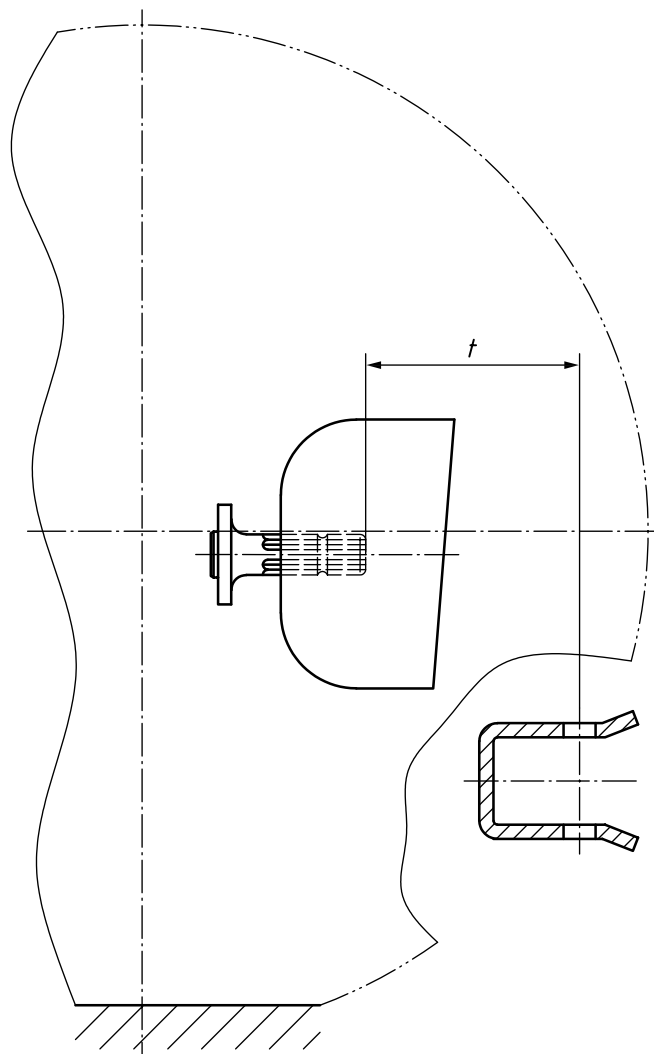

Figure 2 — Non-swivel clevis coupling — Relation to power take-off (PTO)

Table 2 — Distances between non-swivel coupling and power take-off (PTO)

Coupling type	$t \pm 10$ mm	
	PTO types 1 and 2	PTO type 3
w	80–400	65–500
x	100–400	85–500
y	120–400	105–500
z	130–400	115–500

7.2 Vertical location

The height above the ground of the coupling device shall be in accordance with one of the following relationships (see Figure 3):

$$h_1 \leq \frac{[(m_a - 0,2m_t) \times l - S \times c]}{0,8 \times (0,8m_t + S)}$$

or

$$h_2 \leq \frac{[(m_{1a} - 0,2m_{1t}) \times l - S \times c]}{0,8 \times (0,8m_{1t} + S)}$$

where

m_t is the mass of the tractor or towing vehicle, in kg;

m_{1t} is the mass of the tractor or towing vehicle with the ballast weight on the front axle, in kg;

m_a is the load on the front axle of the unladen tractor or towing vehicle, in kg;

m_{1a} is the load on the front axle of the tractor or towing vehicle with the ballast weight on the front axle, in kg;

l is the tractor or towing vehicle wheelbase, in mm;

S is the vertical load on the coupling point, in kg;

c is the distance, in mm, between the reference centre of the mechanical coupling and the vertical plane passing through the axle of the rear wheels of the tractor or towing vehicle.

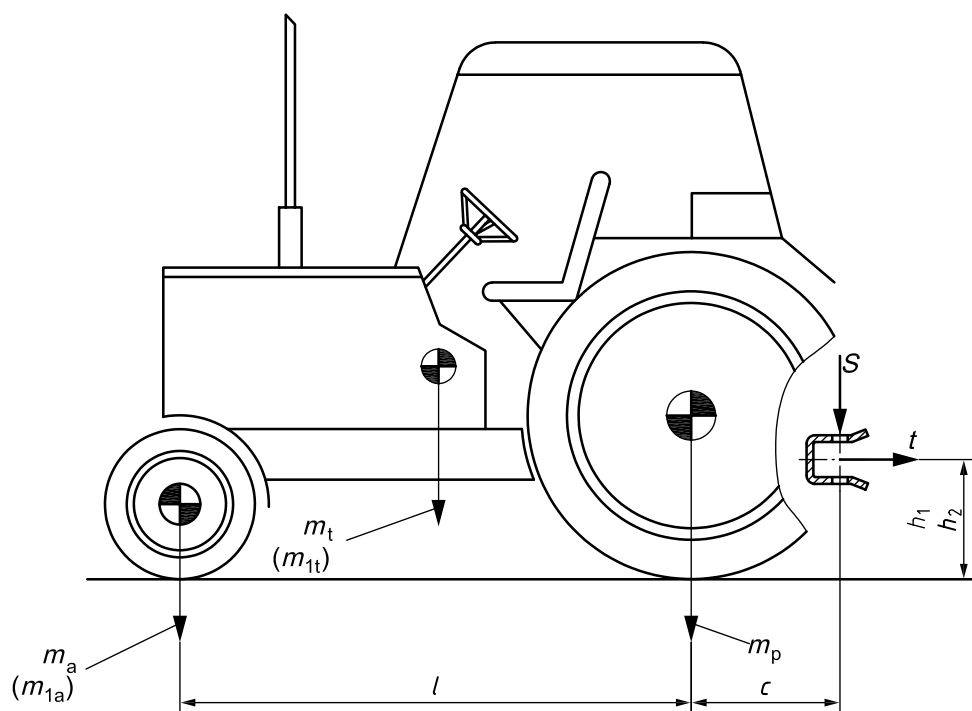

NOTE m_p is the load on the rear axle of the unladen tractor.

Figure 3 — Non-swivel clevis coupling — Vertical location

8 Permissible mechanical connections between rings and couplings

See Table 3.

Table 3 — Permissible mechanical connections between rings and couplings

Coupling	Ring
ISO 6489-5 Shape w	ISO 5692-3 Shape W
ISO 6489-5 Shape x	ISO 5692-3 Shape X
ISO 6489-5 Shape y	ISO 5692-3 Shape Y
ISO 6489-5 Shape z	ISO 5692-3 Shape Z

9 Marking

The non-swivel clevis coupling shall have a permanent and visible coupling shape letter marking for identification.

Annex A (informative)

Recommended mechanical connection combinations between towing and towed vehicles

Towing vehicle	Towed vehicle
ISO 6489-1:1991, hook type	ISO 5692:1979/ISO 5692-1:2004, hitch ring (50 mm hole centre, 30 mm ring diameter)
ISO 6489-1:2001, hook type ^a	ISO 5692:1979/ISO 5692-1:2004, hitch ring (50 mm hole centre, 30 mm ring diameter)
	ISO 20019:2001, hitch ring (50 mm hole centre, 30 to 41 mm ring diameter)
ISO 6489-2:2002, bolt type	ISO 5692-2:2002, coupling ring (40 mm socket)
	ISO 8755:1986, 40 mm drawbar coupling ^b
	ISO 1102:1986, 50 mm drawbar coupling ^b
ISO 6489-4:2004, piton type	ISO 5692:1979/ISO 5692-1:2004, hitch ring (50 mm hole centre, 30 mm ring diameter)
ISO 6489-5:2011, non-swivel clevis coupling	ISO 5692-3:2011, swivel hitch rings
ISO 24347:2005, ball type	ISO 24347 (80 mm ball diameter)
Only these combinations are recommended.	
<p>^a Connecting an ISO 6489-1:2001 hook, manufactured in accordance with the maximum sizes permitted, to hitch rings in accordance with ISO 5692-1 and of minimum dimensions (30 mm ring diameter) according to ISO 20019 could result in a "jerky" connection between the tractor or towing vehicle and the trailer or implement, and less driving comfort.</p> <p>^b Primarily used on trailers towed behind trucks (on-road).</p>	

Bibliography

- [1] ISO 1102:1986, *Commercial road vehicles — Mechanical connections between towing vehicles and trailers — 50 mm drawbar couplings*
- [2] ISO 5692:1979, *Agricultural vehicles — Mechanical connections on towed vehicles — Hitch-rings — Specifications*
- [3] ISO 5692-1:2004, *Agricultural vehicles — Mechanical connections on towed vehicles — Part 1: Dimensions for hitch rings of 50/30 mm cross section*
- [4] ISO 5692-2:2002, *Agricultural vehicles — Mechanical connections on towed vehicles — Part 2: Coupling ring 40 with socket*
- [5] ISO 6489-1:1991, *Agricultural vehicles — Mechanical connections on towing vehicles — Part 1: Hook type*
- [6] ISO 6489-1:2001, *Agricultural vehicles — Mechanical connections between towed and towing vehicles — Part 1: Dimensions of hitch-hooks*
- [7] ISO 6489-2:2002, *Agricultural vehicles — Mechanical connections between towed and towing vehicles — Part 2: Specifications for clevis coupling 40*
- [8] ISO 8755:1986, *Commercial road vehicles — Mechanical connections between towing vehicles and trailers — 40 mm drawbar coupling*
- [9] ISO 20019:2001, *Agricultural vehicles — Mechanical connections on towed vehicles — Dimensions for hitch rings*
- [10] ISO 24347:2005, *Agricultural vehicles — Mechanical connections between towed and towing vehicles — Dimensions of ball-type coupling device (80 mm)*

ICS 65.060.10

Price based on 8 pages