

---

---

**Electrically propelled road vehicles —  
Safety specifications —**

**Part 3:  
Protection of persons against electric  
shock**

*Véhicules routiers électriques — Spécifications de sécurité —*

*Partie 3: Protection des personnes contre les chocs électriques*



Reference number  
ISO 6469-3:2011(E)

© ISO 2011



**COPYRIGHT PROTECTED DOCUMENT**

© ISO 2011

All rights reserved. Unless otherwise specified, no part of this publication may be reproduced or utilized in any form or by any means, electronic or mechanical, including photocopying and microfilm, without permission in writing from either ISO at the address below or ISO's member body in the country of the requester.

ISO copyright office  
Case postale 56 • CH-1211 Geneva 20  
Tel. + 41 22 749 01 11  
Fax + 41 22 749 09 47  
E-mail [copyright@iso.org](mailto:copyright@iso.org)  
Web [www.iso.org](http://www.iso.org)

Published in Switzerland

# Contents

Page

Foreword .....	iv
<b>1 Scope .....</b>	<b>1</b>
<b>2 Normative references .....</b>	<b>1</b>
<b>3 Terms and definitions .....</b>	<b>2</b>
<b>4 Environmental and operational conditions .....</b>	<b>4</b>
<b>5 Voltage classes.....</b>	<b>4</b>
<b>6 Marking.....</b>	<b>5</b>
<b>7 Measures and requirements for protection of persons against electric shock.....</b>	<b>5</b>
<b>8 Test procedures for the protection measures against electric shock.....</b>	<b>10</b>
<b>9 Safety requirements at vehicle crash test .....</b>	<b>13</b>
<b>10 Owner's guide and manual .....</b>	<b>13</b>
<b>Bibliography.....</b>	<b>14</b>

## Foreword

ISO (the International Organization for Standardization) is a worldwide federation of national standards bodies (ISO member bodies). The work of preparing International Standards is normally carried out through ISO technical committees. Each member body interested in a subject for which a technical committee has been established has the right to be represented on that committee. International organizations, governmental and non-governmental, in liaison with ISO, also take part in the work. ISO collaborates closely with the International Electrotechnical Commission (IEC) on all matters of electrotechnical standardization.

International Standards are drafted in accordance with the rules given in the ISO/IEC Directives, Part 2.

The main task of technical committees is to prepare International Standards. Draft International Standards adopted by the technical committees are circulated to the member bodies for voting. Publication as an International Standard requires approval by at least 75 % of the member bodies casting a vote.

Attention is drawn to the possibility that some of the elements of this document may be the subject of patent rights. ISO shall not be held responsible for identifying any or all such patent rights.

ISO 6469-3 was prepared by Technical Committee ISO/TC 22, *Road vehicles*, Subcommittee SC 21, *Electrically propelled road vehicles*.

This second edition cancels and replaces the first edition (ISO 6469-3:2001), which has been technically revised. Technical Corrigendum ISO 6469-3:2001/Cor.1:2003 has been incorporated.

ISO 6469 consists of the following parts, under the general title *Electrically propelled road vehicles — Safety specifications*:

- *Part 1: On-board rechargeable energy storage system (RESS)*
- *Part 2: Vehicle operational safety means and protection against failures*
- *Part 3: Protection of persons against electric shock*

# Electrically propelled road vehicles — Safety specifications —

## Part 3: Protection of persons against electric shock

**IMPORTANT** — The electronic file of this document contains colors which are considered to be useful for the correct understanding of the document. Users should therefore consider printing this document using a color printer.

### 1 Scope

This part of ISO 6469 specifies requirements for the electric propulsion systems and conductively connected auxiliary electric systems, if any, of electrically propelled road vehicles for the protection of persons inside and outside the vehicle against electric shock.

It does not apply to motorcycles and vehicles not primarily intended as road vehicles, such as material handling trucks or forklifts.

It applies only to on-board electric circuits with maximum working voltages according to voltage class B.

It does not provide comprehensive safety information for manufacturing, maintenance and repair personnel.

**NOTE** Requirements for the electric power supply interface conductively connected to the external power supply (grid) for charging the RESS are also specified in IEC 61851-1 and IEC 61851-21.

### 2 Normative references

The following referenced documents are indispensable for the application of this document. For dated references, only the edition cited applies. For undated references, the latest edition of the referenced document (including any amendments) applies.

ISO 6469-1, *Electrically propelled road vehicles — Safety specifications — Part 1: On-board rechargeable energy storage system (RESS)*

ISO 7010, *Graphical symbols — Safety colours and safety signs — Registered safety signs*

ISO 20653, *Road vehicles — Degrees of protection (IP-Code) — Protection of electrical equipment against foreign objects, water and access*

IEC 60664 (all parts), *Insulation coordination for equipment within low-voltage systems*

### 3 Terms and definitions

For the purposes of this document, the following terms and definitions apply.

- 3.1**  
**auxiliary electric system**  
on-board vehicle system, other than the propulsion system, that operates on electric energy
- 3.2**  
**balance of electric power system**  
remaining portion of a **voltage class B** (3.31) electric circuit when all RESS and **fuel cell stacks** (3.18) are disconnected
- 3.3**  
**barrier**  
part providing protection against direct contact from any usual direction of access
- 3.4**  
**basic insulation**  
insulation applied to **live parts** (3.22) for protection against **direct contact** (3.10)
- NOTE Basic insulation does not necessarily include isolations used exclusively for functional purposes.
- 3.5**  
**basic protection**  
protection against **direct contact** (3.10) with **live parts** (3.22) under fault-free conditions
- 3.6**  
**battery pack**  
mechanical assembly comprising battery cells and retaining frames or trays, and possibly components for battery management
- 3.7**  
**clearance**  
shortest distance in air between **conductive parts** (3.8)
- 3.8**  
**conductive part**  
part capable of conducting electric current
- 3.9**  
**creepage distance**  
shortest distance along the surface of a solid insulating material between two **conductive parts** (3.8)
- 3.10**  
**direct contact**  
contact of persons with **live parts** (3.22)
- 3.11**  
**double insulation**  
insulation system comprising both **basic insulation** (3.4) and **supplementary insulation** (3.28)
- 3.12**  
**electric chassis**  
**conductive parts** (3.8) of a vehicle that are electrically connected and whose potential is taken as reference
- 3.13**  
**electric shock**  
physiological effect resulting from an electric current passing through a human body

**3.14****electrically propelled vehicle**

vehicle with one or more **electric drive(s)** (3.15) for vehicle propulsion

**3.15****electric drive**

combination of traction motor, power electronics and their associated controls for the conversion of electric to mechanical power and vice versa

**3.16****enclosure**

part providing protection of equipment against **direct contact** (3.10) from any direction

**3.17****exposed conductive part**

**conductive part** (3.8) of the electric equipment that can be touched by a test finger according to IPXXB (see ISO 20653) after removing barriers/enclosures that can be removed without using tools and that is not normally live, but which can become live under fault conditions

**3.18****fuel cell stack**

assembly of two or more fuel cells that are electrically connected

**3.19****fuel cell system**

system, typically containing the following subsystems: **fuel cell stack** (3.18), air processing, fuel processing, thermal management, water management, and their control

**3.20****isolation resistance**

resistance between live parts of **voltage class B** (3.31) electric circuit and the **electric chassis** (3.12) as well as the **voltage class A** (3.30) system

**3.21****isolation resistance monitoring system**

system that periodically or continuously monitors the **isolation resistance** (3.20) between **live parts** (3.22) and the **electric chassis** (3.12)

**3.22****live part**

conductor or **conductive part** (3.8) intended to be electrically energized in normal use

**3.23****maximum working voltage**

highest value of a.c. voltage (rms) or of d.c. voltage that can occur in an electric system under any normal operating conditions according to the manufacturer's specifications, disregarding transients

**3.24****potential equalization**

electric connections of exposed **conductive parts** (3.8) of the electric equipment to minimize differences in potential between these parts

**3.25****protection degree**

protection provided by a **barrier** (3.3)/**enclosure** (3.16) related to the contact with **live parts** (3.22) by a test probe, such as a test finger (IPXXB), a test rod (IPXXC), or a test wire (IPXXD) in accordance with ISO 20653

**3.26**  
**rechargeable energy storage system**  
**RESS**

system that stores energy for delivery of electric energy and that is rechargeable

EXAMPLES Batteries, capacitors.

**3.27**  
**reinforced insulation**

insulation of **live parts** (3.22) for protection against **electric shock** (3.13) equivalent to **double insulation** (3.11)

NOTE Reinforced insulation does not imply that the insulation shall be a homogeneous piece. The reinforced insulation may be composed of several layers that cannot be tested individually as supplementary or basic insulation.

**3.28**  
**supplementary insulation**

independent insulation applied in addition to **basic insulation** (3.4) for protection against **electric shock** (3.13) in the event of a failure of the **basic insulation** (3.4)

**3.29**  
**traction battery**

collection of all **battery packs** (3.6) that are electrically connected, for the supply of electric power to the **electric drive** (3.15) and to the conductively connected auxiliary electric system, if any

**3.30**  
**voltage class A**

classification of an electric component or circuit with a maximum working voltage of less than 30 V a.c. (rms) or 60 V d.c.

NOTE For more details see Clause 5.

**3.31**  
**voltage class B**

classification of an electric component or circuit with a maximum working voltage between 30 V a.c. (rms) and 1 000 V a.c. (rms) or between 60 V d.c. and 1 500 V d.c.

**4 Environmental and operational conditions**

The requirements given in this part of ISO 6469 shall be met across the range of environmental and operational conditions for which the electrically propelled vehicle is designed to operate, as specified by the vehicle manufacturer.

NOTE See ISO 16750 for guidance.

**5 Voltage classes**

Depending on its maximum working voltage, *U*, an electric component or circuit belongs to one of the voltage classes specified in Table 1.

**Table 1 — Voltage classes**

Voltage class	Maximum working voltage	
	d.c. V	a.c. V (rms value)
A	$0 < U \leq 60$	$0 < U \leq 30$
B	$60 < U \leq 1\ 500$	$30 < U \leq 1\ 000$

NOTE The values 60 V d.c./30 V a.c. (rms) are selected taking into account humid weather conditions.



## 6 Marking

### 6.1 Marking of voltage class B electric components

The symbol W 012 in accordance with ISO 7010 shown in Figure 1 shall appear on (preferably) or near voltage class B electric power sources as RESS and fuel cell stacks.

The same symbol shall be visible on barriers and enclosures, which, when removed, expose live parts of voltage class B electric circuits. Accessibility and removability of barriers/enclosures should be considered when evaluating the requirement for the symbol.



Figure 1 — Marking of voltage class B electric components

### 6.2 Marking of voltage class B wiring

The outer covering of cables and harness for voltage class B electric circuits not within enclosures or behind barriers shall be marked with orange color.

Voltage class B connectors may be identified by the harnesses to which the connector is attached.

NOTE Specifications of the orange color are given e.g. in standards in the US (8.75R5.75/12.5) and in Japan (8.8R5.8/12.5) according to the Munsell color system.

## 7 Measures and requirements for protection of persons against electric shock

### 7.1 General

Protection against electric shock shall be composed of

- basic protection measures against direct contact with live parts;
- measures for protection under single-failure conditions.

The protection measures shall meet the requirements as described in 7.2 and 7.3 and compliance shall be tested in accordance with the test methods specified in Clause 8.

### 7.2 Basic protection measures

Persons shall be protected against direct contact with the live parts of the voltage class B electric circuits.

The protection measures against direct contact shall be provided by either one or both of the following:

- basic insulation of the live parts;
- barriers/enclosures, preventing access to the live parts.

The barriers/enclosures may be electrically conductive or non-conductive.

## 7.3 Protection under single-failure conditions

### 7.3.1 Potential equalization

As a general rule, exposed conductive parts of voltage class B electric equipment, including exposed conductive barriers/enclosures, shall be bonded to the electric chassis for potential equalization in accordance with the requirements in 7.9.

### 7.3.2 Isolation resistance

The voltage class B electric circuits intended to be not conductively connected to the grid shall have sufficient isolation resistance in accordance with the requirements in 7.7.

If the minimum isolation resistance requirement of such circuits cannot be maintained under all operational conditions and over the entire service life, one of the following measures shall be applied:

- monitoring of the isolation resistance periodically or continuously; an appropriate warning shall be provided if loss of isolation resistance is detected; the voltage class B system may be deactivated depending on the operational state of the vehicle or the ability to activate the voltage class B system may be limited;
- double or reinforced insulation instead of basic insulation;
- one or more layers of insulation, barriers and/or enclosures in addition to the basic protection;
- rigid barriers/enclosures with sufficient mechanical robustness and durability, over the vehicle service life.

Requirements on isolation resistance for voltage class B electric circuits intended to be conductively connected to the grid are given in 7.10.2.

NOTE 1 Isolation resistances below the required minimum values can occur due to deterioration of fuel cell (FC) systems' cooling liquids or of certain battery types.

NOTE 2 Coordination between multiple isolation monitoring systems can be necessary, e.g. during charging.

NOTE 3 The isolation resistance is approximately zero for a voltage class B electric circuit conductively connected to the grid.

NOTE 4 Additional layer(s) of insulation and double or reinforced insulation include, but are not limited to, those for voltage class B wiring.

NOTE 5 The rigid barriers/enclosures include, but are not limited to, power control enclosures, motor housings, connector casings and housings, etc. They can be used as single measure instead of basic barriers/enclosures to meet both basic and single-failure protection requirements.

### 7.3.3 Capacitive couplings

**7.3.3.1** Capacitive couplings between a voltage class B potential and electric chassis usually result from Y capacitors, used for electromagnetic compatibility (EMC) reasons, or parasitic capacitive couplings.

**7.3.3.2** For d.c. body currents caused by discharge of such capacitive couplings when touching d.c. class B voltage, one of the following options shall be fulfilled:

- energy of the total capacitance between any energized voltage class B live part and the electric chassis shall be  $<0,2$  J at its maximum working voltage; total capacitance should be calculated based on designed values of related parts and components;
- alternative mechanical or electrical measures for d.c. voltage class B electric circuits; see 7.3.3.4.

**7.3.3.3** For a.c. body currents caused by such capacitive couplings when touching a.c. class B voltage one of the following options shall be fulfilled:

- a.c. body current shall not exceed 5 mA when measured in accordance with IEC 60950-1;
- alternative mechanical or electrical measures for a.c. voltage class B electric circuits; see 7.3.3.4.

**7.3.3.4** Alternative electrical or mechanical measures include the following:

- double or reinforced insulation instead of basic insulation;
- one or more layers of insulation, barriers and/or enclosures in addition to the basic protection;
- rigid barriers/enclosures with sufficient mechanical robustness and durability, over the vehicle service life.

#### **7.3.4 De-energization**

The voltage class B electric circuit in question may be de-energized as a protection measure. The monitoring of faults within the circuit or the detection of events may be used to trigger the de-energization. One of the following conditions shall be met for the de-energized circuit.

- The voltage shall be reduced to less than 30 V a.c. (rms) for a.c. circuits and 60 V d.c. for d.c. circuits.
- The total stored energy of the circuit shall be <0,2 J.

The transition time to reach the de-energized state shall be specified by the manufacturer in accordance with expected failures and operating conditions.

#### **7.4 Alternative approach for protection against electric shock**

As an alternative to 7.3, the vehicle manufacturer shall conduct an appropriate hazard analysis and establish a set of measures which give sufficient protection against electric shock under single-failure conditions.

#### **7.5 Requirements for insulation**

If protection is provided by insulation, the live parts of the electric system shall be totally encapsulated by insulation that can be removed only by destruction.

The insulating material shall be suitable to the maximum working voltage and temperature ratings of the vehicle and its systems (see also Clause 4).

The insulation shall have sufficient capability to withstand the usual voltage. Compliance shall be tested in accordance with 8.3.

#### **7.6 Requirements for barriers/enclosures**

##### **7.6.1 General**

If protection is provided by barriers/enclosures, live parts shall be placed inside enclosures or behind barriers, preventing access to the live parts from any usual direction of access.

The barriers/enclosures shall provide sufficient mechanical resistance under normal operating conditions, as specified by the manufacturer.

If barriers/enclosures are accessible directly, they shall be opened or removed only by use of tools or maintenance keys or they shall have means to deactivate live parts with class B voltage, e.g. an interlock.

See 6.1 for marking of barriers/enclosures.

## 7.6.2 Protection degrees

### 7.6.2.1 Protection degrees for barriers/enclosures

Barriers/enclosures shall comply with the protection degree IPXXB at a minimum.

Barriers/enclosures in passenger and load compartments shall comply with the protection degree IPXXD at a minimum.

### 7.6.2.2 Protection degrees for connectors

If connector parts can be disconnected without tools and can have class B voltage in the unmated condition, the connector shall comply with IPXXB at a minimum in the unmated condition.

Requirements for the vehicle power inlet are defined in 7.10.

## 7.7 Isolation resistance requirements

### 7.7.1 General

The minimum isolation resistance shall be at least 100  $\Omega/V$  for d.c. circuits and at least 500  $\Omega/V$  for a.c. circuits. The reference shall be the maximum working voltage.

NOTE Hazard of electric shock occurs when electric currents depending on value and duration pass through the human body. Harmful effects can be avoided if the current is within zone DC-2 for d.c. or zone AC-2 for a.c. as shown in IEC/TS 60479-1:2005, Figure 20 and Figure 22, respectively. The relation of harmful body currents and other wave forms and frequencies is described in IEC/TS 60479-2. The isolation resistance requirements of 100  $\Omega/V$  for d.c. or 500  $\Omega/V$  for a.c. allow body currents of 10 mA and 2 mA, respectively.

To meet the above requirement for the entire circuit, it is necessary to have a higher isolation resistance for each component, depending on the number of the components and the structure of the circuit to which they belong.

If d.c. and a.c. voltage class B electric circuits are conductively connected (see Figure 2), one of the following two options shall be fulfilled.

- Option 1: Meet at least the 500  $\Omega/V$  requirement for the combined circuit.
- Option 2: Meet at least the 100  $\Omega/V$  requirements for the entire conductively connected circuit, if at least one of the additional protection measures as defined in 7.7.2 is applied to the a.c. circuit.

### 7.7.2 Additional protection measures for the a.c. circuit

One or a combination of the following measures in addition to or instead of the basic protection measures as described in 7.2 shall be applied to provide protection against single failures to address the failures, for which it is intended:

- double or reinforced insulation instead of basic insulation;
- one or more layers of insulation, barriers and/or enclosures in addition to the basic protection;
- rigid barriers/enclosures with sufficient mechanical robustness and durability, over the vehicle service life.

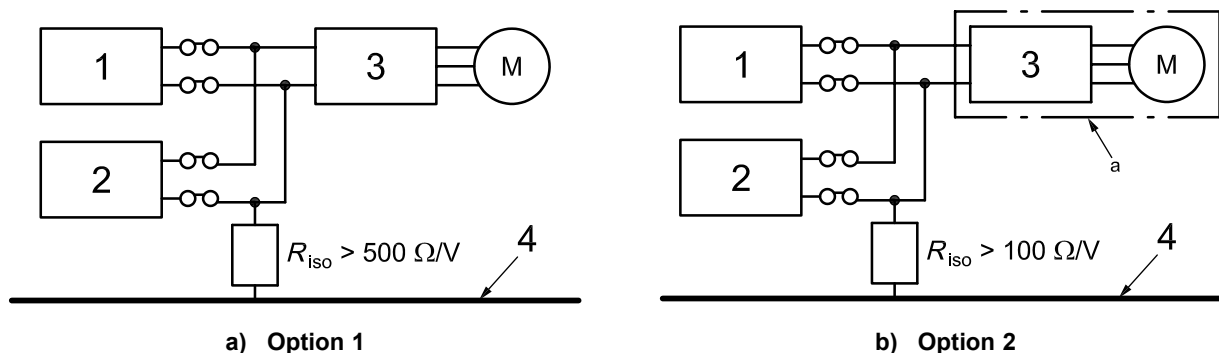
**Key**

- 1 fuel cell system
- 2 traction battery
- 3 inverter
- 4 vehicle electric chassis
- a a.c. circuit.

NOTE Figure 2 is based on fuel cell hybrid electric vehicle (FCHEV) as an example.

**Figure 2 — Isolation resistance requirements for voltage class B systems with conductively connected a.c. and d.c. circuits**

## 7.8 Requirements for insulation coordination

The voltage class B components and wiring shall fulfil the applicable sections of IEC 60664 on clearance, creepage distance and solid insulation or meet the withstand voltage capability according to the withstand voltage test in 8.3.

## 7.9 Requirements of potential equalization

All components forming the potential equalization current path (conductors, connections) shall withstand the maximum current in a single-failure situation.

The resistance of the potential equalization path between any two exposed conductive parts of the voltage class B electric circuit that can be touched simultaneously by a person shall not exceed 0,1  $\Omega$ .

## 7.10 Requirements for vehicle power inlet

### 7.10.1 Protective measures

The vehicle power inlet shall comply with at least one of the following requirements:

- de-energize the circuit within 1 s;
- de-energize in a time specified by the manufacturer and IPXXB.

### 7.10.2 Grounding and isolation resistance requirement for the vehicle power inlet

#### 7.10.2.1 Vehicle power inlet conductively connected to the grid

The vehicle power inlet intended to be conductively connected to the grid shall have a terminal for connecting the vehicle electric chassis to the ground of the grid.

The total isolation resistance at the vehicle power inlet, which includes circuits conductively connected to the grid during charging, shall be at least 1 M $\Omega$  when the charge coupler is disconnected.

NOTE See also IEC 61851.

### 7.10.2.2 Vehicle power inlet not conductively connected to the grid

The total isolation resistance of the vehicle power inlet, which includes circuits conductively connected to the inlet during charging, shall comply with the requirements in 7.7 when the charge coupler is disconnected.

A terminal connecting the vehicle chassis to the external power supply shall be provided if potential equalization is required.

## 8 Test procedures for the protection measures against electric shock

### 8.1 General

The tests to verify the protection measures according to Clause 7 shall in principle be performed on each voltage class B electric circuit on the vehicle, when the charge coupler is disconnected.

If the safety aspects in relation to the whole vehicle are not affected, the tests may be performed outside the vehicle on the components or parts of the voltage class B electric circuits individually instead.

### 8.2 Isolation resistance measurements for voltage class B electric circuits

#### 8.2.1 Preconditioning and conditioning

Prior to the measurement, the device under test (DUT) shall be subjected to a preconditioning period of at least 8 h at  $(5 \pm 2) ^\circ\text{C}$ , followed by a conditioning period of 8 h at a temperature of  $(23 \pm 5) ^\circ\text{C}$ , a humidity of  $90^{+10}_{-5} \%$ , and an atmospheric pressure of between 86 kPa and 106 kPa.

Alternative preconditioning and conditioning parameters may be selected provided transition across the dew point occurs shortly after the beginning of the conditioning period.

The isolation resistance shall be measured during the conditioning period at a rate from which the lowest value can be determined.

#### 8.2.2 Isolation resistance measurements of the balance of electric power systems

The test voltage shall be a d.c. voltage of at least the maximum working voltage of the voltage class B power system and be applied for a time long enough to obtain stable reading.

If the system has several voltage ranges (e.g. because of boost converter) in conductively connected circuit and some of the components cannot withstand the maximum working voltage of the entire circuit, the isolation resistances of components can be measured separately by applying their own maximum working voltages after those components are disconnected.

The following test procedure combines the measurement of the isolation resistance of the live parts of the voltage class B balance of electric power systems against the vehicle electric chassis and against the live parts of the voltage class A balance of auxiliary electric systems.

- Traction batteries shall be disconnected at their terminals from the power system.
- Electric power sources of the voltage class B power systems other than the traction batteries (fuel cell stacks, capacitors) may be disconnected at their terminals from the power system; if they remain connected, power generation shall be deactivated.
- Barriers and enclosures shall be included unless evaluations prove otherwise.
- All live parts of the balance of electric power systems (voltage class B) shall be connected to each other.
- All exposed conductive parts of the balance of electric power system shall be connected to the electric chassis.

- Batteries of the auxiliary electric systems (voltage class A) shall be disconnected at their terminals from the auxiliary circuits.
- All live parts of the balance of auxiliary electric systems (voltage class A) shall be connected to the electric chassis.

Then the test voltage shall be applied between the connected live parts of the voltage class B balance of electric power systems and the electric chassis.

The measurements shall be performed using suitable instruments that can apply d.c. voltage (e.g. megohmmeter, provided they deliver the required test voltage).

Alternatively the isolation resistance may be measured using the test procedure for the measurement of the RESS as given in ISO 6469-1 with the balance of electric power system connected to an external power source.

### 8.2.3 Isolation resistance measurement of the voltage class B electric power sources

The measurement of the isolation resistance of an RESS, if any, shall be in accordance with ISO 6469-1.

The measurement of the isolation resistance of a fuel cell stack, if any, shall be in accordance with ISO 6469-1 with the fuel cell stack in operation.

Alternatively for the measurement of the isolation resistance of a fuel cell stack, the entire mechanical structure of the fuel cell system (including the cooling system with its cooling medium) shall be considered. Prior to the measurement, stop power generation after operation at maximum output according to the manufacturer's specification. The voltage across the fuel-cell stack power terminals shall be discharged. All cables shall be disconnected from the fuel-cell stack power terminals, and all other cables from other electric terminals of the fuel-cell stack. All cooling pipes, fuel pipes, and air pipes shall remain connected. The applied test voltage shall be at least the maximum open circuit voltage of the fuel cell stack. Apart from these specific conditions, the procedure shall be performed as given in 8.2.2.

### 8.2.4 Isolation resistance measurement of entire voltage class B electric circuits

The isolation resistance of entire conductively connected voltage class B electric circuits may be measured using the test procedure for the measurement of the RESS given in ISO 6469-1 with the balance of electric power system connected to the voltage class B power sources.

Alternatively, the isolation resistance of entire conductively connected voltage class B electric circuits may be measured using an isolation resistance monitoring system, if installed on the vehicle, provided that its accuracy is sufficiently high.

In case electric or electronic switches exist in the circuit (e. g. transistors in power electronics), these switches shall be activated. If these switches cannot be activated, the relevant part of the circuit may be measured separately in accordance with 8.2.2.

Instead of being measured, the isolation resistance of the entire conductively connected circuit may be calculated using the measured resistances of the power sources and the balance of electric power system.

## 8.3 Withstand voltage test

### 8.3.1 General

This test is intended to demonstrate the adequacy of the protection measures to isolate live parts of voltage class B electric circuits.

This test shall be applied for the balance of the electric power system.

The test may be performed at the component level at the discretion of the manufacturer.

Surge protective devices (SPDs) that can affect the test result shall be disconnected before testing. Components such as RFI filters shall be included in the impulse test, but it can be necessary to disconnect them during a.c. tests.

NOTE Test procedures and criteria of high voltage cables conductively connected to grid are specified in applicable sections of appropriate IEC standards (e.g. IEC 60227, IEC 60245, etc.).

### 8.3.2 Preconditioning and conditioning

If not otherwise specified by the vehicle manufacturer, the following procedure shall apply.

- Preconditioning at a temperature of  $30\text{ °C} \pm 2\text{ °C}$  and a duration that ensures a constant temperature.
- Conditioning: for 48 h at a temperature of  $23\text{ °C} \pm 2\text{ °C}$ , a humidity of  $93\% \pm 5\%$ , and an atmospheric pressure of 86 kPa to 106 kPa.

### 8.3.3 Test procedure

#### 8.3.3.1 General

8.3.3.1.1 This test shall include barriers/enclosures, unless evaluations prove otherwise.

8.3.3.1.2 The following test procedure shall be applied.

- All voltage class B live parts of the DUT shall be connected to each other.
- For components with conductive housing, all live parts of the voltage class A electric circuit of the DUT and all exposed conductive parts of the DUT shall be connected to each other.
- For components with non-conductive housing, all live parts of the voltage class A electric circuit of the DUT and an electrode wrapped around the housing shall be connected to each other.

8.3.3.1.3 At the end of the conditioning, the test voltage specified in 8.3.3.2 or 8.3.3.3 shall be applied:

- between connected live parts of voltage class B electric circuits and a housing with an electrically conductive surface;
- between connected live parts of voltage class B electric circuits and an electrode wrapped around the housing in the case of non-conductive housing.

#### 8.3.3.2 Test voltage for components not conductively connected to the grid

The test voltage, a.c. or d.c., shall be more than the highest voltage that can actually occur to the component. The test voltage shall be derived from the relevant over-voltages of the electric circuit to which the component is connected. Transient over-voltages that can be expected, including influences from other connections to grid, if any, shall be considered. The test voltage and its duration shall be specified, considering the applicable parts and sections of IEC 60664 by the vehicle manufacturer.

These test requirements also apply for voltage class B components connected to d.c. charging systems that are not conductively connected to the a.c. grid.

#### 8.3.3.3 Test voltage for components conductively connected to the grid

##### 8.3.3.3.1 General

These test requirements also apply for voltage class B components connected to d.c. charging systems that are conductively connected to the a.c. grid.



### 8.3.3.3.2 Standard test voltage

The following a.c. test voltage of a frequency between 50 Hz and 60 Hz shall be applied for 1 min:

- $(2U + 1\ 000)$  V a.c. (rms) if basic insulation applies;
- $(2U + 3\ 250)$  V a.c. (rms) if double insulation and reinforced insulation applies;

where  $U$ , expressed in volts, is the maximum working voltage of the electric circuit to which the component is connected.

The equivalent d.c. test voltage is 1,41 times the a.c. (rms) value.

### 8.3.3.3.3 Test voltage of alternative approach

This test condition is specified in IEC 60664-1 for verifying the withstand voltage capability. Both test voltages for impulse voltage withstand test and a.c. voltage test shall be applied.

For the impulse voltage withstand test, the applicable test voltages given in IEC 60664-1 for over-voltage category I or category II shall be applied. 160 % of the voltage value shall be applied for double insulation or reinforced insulation.

The over-voltage category I or category II in accordance with IEC 60664-1 shall be selected by the vehicle manufacturer.

For the a.c. voltage test,  $U_n + 1\ 200$  V (rms) for 60 s where  $U_n$  is the nominal line-to-neutral voltage of the neutral-earthed supply system. Twice the voltage value shall be applied for double insulation or reinforced insulation.

### 8.3.4 Test criteria

Neither dielectric breakdown nor flashover shall occur during application of the test voltage.

## 8.4 Continuity test for potential equalization

The potential equalization resistances shall be tested with a test current of at minimum 1 A and a voltage <60 V d.c., which shall be passed through the potential current path between any two exposed conductive parts for at least 5 s. This path shall be isolated from other unintended potential paths for measurement. These conducting parts shall include voltage class B component housings, connections to electric chassis and the vehicle electric chassis or barriers/enclosures.

A lower test current and/or a shorter test time may be used, provided the accuracy of the potential equalization resistance test results remain on a sufficiently accuracy level.

The voltage drop between any two reachable exposed conductive parts in a distance of 2,5 m shall be measured and the resistance calculated from the current and this voltage drop.

NOTE 2,5 m is the usual distance which a person can reach.

## 9 Safety requirements at vehicle crash test

The vehicle crash test and the test requirements shall be according to applicable national and/or international standards or regulations.

## 10 Owner's guide and manual

Special attention to electric safety shall be given in the owner's manual.

## Bibliography

- [1] IEC 60227 (all parts), *Polyvinyl chloride insulated cables of rated voltages up to and including 450/750 V*
- [2] IEC 60245 (all parts), *Rubber insulated cables — Rated voltages up to and including 450/750 V*
- [3] IEC/TS 60479-1:2005, *Effects of current on human beings and livestock — Part 1: General aspects*
- [4] IEC/TS 60479-2, *Effect of current on human beings and livestock — Part 2: Special aspects*
- [5] IEC 60950-1, *Information technology equipment — Safety — Part 1: General requirements*
- [6] IEC 61851-1, *Electric vehicle conductive charging system — Part 1: General requirements*
- [7] IEC 61851-21, *Electric vehicle conductive charging system — Part 21: Electric vehicle requirements for conductive connection to an a.c./d.c. supply*
- [8] ISO 16750 (all parts), *Road vehicles — Environmental conditions and testing for electrical and electronic equipment*

-----

---

---

**ICS 43.120**

Price based on 14 pages