

---

---

**Rubber- or plastics-coated fabrics —  
Determination of fogging characteristics  
of trim materials in the interior of  
automobiles**

*Textiles revêtus de caoutchouc ou de plastique — Détermination des  
caractéristiques d'embuage des matériaux de garnissage utilisés dans  
l'habitacle automobile*



**PDF disclaimer**

This PDF file may contain embedded typefaces. In accordance with Adobe's licensing policy, this file may be printed or viewed but shall not be edited unless the typefaces which are embedded are licensed to and installed on the computer performing the editing. In downloading this file, parties accept therein the responsibility of not infringing Adobe's licensing policy. The ISO Central Secretariat accepts no liability in this area.

Adobe is a trademark of Adobe Systems Incorporated.

Details of the software products used to create this PDF file can be found in the General Info relative to the file; the PDF-creation parameters were optimized for printing. Every care has been taken to ensure that the file is suitable for use by ISO member bodies. In the unlikely event that a problem relating to it is found, please inform the Central Secretariat at the address given below.



**COPYRIGHT PROTECTED DOCUMENT**

© ISO 2007

All rights reserved. Unless otherwise specified, no part of this publication may be reproduced or utilized in any form or by any means, electronic or mechanical, including photocopying and microfilm, without permission in writing from either ISO at the address below or ISO's member body in the country of the requester.

ISO copyright office  
Case postale 56 • CH-1211 Geneva 20  
Tel. + 41 22 749 01 11  
Fax + 41 22 749 09 47  
E-mail [copyright@iso.org](mailto:copyright@iso.org)  
Web [www.iso.org](http://www.iso.org)

Published in Switzerland

**Contents**

Page

<b>Foreword</b> .....	<b>iv</b>
<b>1 Scope</b> .....	<b>1</b>
<b>2 Normative references</b> .....	<b>1</b>
<b>3 Principle</b> .....	<b>1</b>
<b>4 Materials</b> .....	<b>2</b>
<b>5 Apparatus</b> .....	<b>2</b>
<b>6 Test pieces and test samples</b> .....	<b>4</b>
<b>7 Conditioning</b> .....	<b>5</b>
<b>8 Procedure</b> .....	<b>5</b>
<b>8.1 Cleaning</b> .....	<b>5</b>
<b>8.2 Control tests</b> .....	<b>5</b>
<b>8.3 Arrangement of test pieces and test samples</b> .....	<b>6</b>
<b>8.4 Measurements prior to the fogging test</b> .....	<b>6</b>
<b>8.5 Fogging test</b> .....	<b>6</b>
<b>9 Expression of results</b> .....	<b>7</b>
<b>10 Precision</b> .....	<b>8</b>
<b>11 Test report</b> .....	<b>8</b>
<b>Annex A (informative) Precision results</b> .....	<b>9</b>
<b>Annex B (informative) Guidance on using precision results</b> .....	<b>10</b>
<b>Annex C (normative) DIDP reference liquid</b> .....	<b>11</b>
<b>Bibliography</b> .....	<b>12</b>

## Foreword

ISO (the International Organization for Standardization) is a worldwide federation of national standards bodies (ISO member bodies). The work of preparing International Standards is normally carried out through ISO technical committees. Each member body interested in a subject for which a technical committee has been established has the right to be represented on that committee. International organizations, governmental and non-governmental, in liaison with ISO, also take part in the work. ISO collaborates closely with the International Electrotechnical Commission (IEC) on all matters of electrotechnical standardization.

International Standards are drafted in accordance with the rules given in the ISO/IEC Directives, Part 2.

The main task of technical committees is to prepare International Standards. Draft International Standards adopted by the technical committees are circulated to the member bodies for voting. Publication as an International Standard requires approval by at least 75 % of the member bodies casting a vote.

Attention is drawn to the possibility that some of the elements of this document may be the subject of patent rights. ISO shall not be held responsible for identifying any or all such patent rights.

ISO 6452 was prepared by Technical Committee ISO/TC 45, *Rubber and rubber products*, Subcommittee SC 4, *Products (other than hoses)*.

This second edition cancels and replaces the first edition (ISO 6452:2000), which has been technically revised.

# Rubber- or plastics-coated fabrics — Determination of fogging characteristics of trim materials in the interior of automobiles

**WARNING —** Persons using this International Standard should be familiar with normal laboratory practice. This standard does not purport to address all of the safety problems, if any, associated with its use. It is the responsibility of the user to establish appropriate safety and health practices and to ensure compliance with any national regulatory conditions.

## 1 Scope

This International Standard specifies a test method which is intended to determine the fogging characteristics of rubber- or plastics-coated fabrics that are used as trim materials in the interior of motor vehicles.

The method may also be applicable to fluid, pasty, powdered or solid raw materials which are the basis for such trim materials or from which the materials are manufactured. The method may also be applicable to other materials and finished products.

The procedure is applicable to the measurement of fog condensate on glass surfaces within the limits of the test conditions. This test will not measure or cannot measure accurately those cases in which:

- the surface tension of the condensate is low, resulting in early coalescing into a thin transparent film;
- the condensate is present in such a large quantity that the droplets coalesce and form a heavy oily/clear film (this heavy film gives false readings).

In such cases, the gravimetric method is preferred.

## 2 Normative references

The following referenced documents are indispensable for the application of this document. For dated references, only the edition cited applies. For undated references, the latest edition of the referenced document (including any amendments) applies.

ISO/TR 9272, *Rubber and rubber products — Determination of precision for test method standards*

## 3 Principle

A test piece is heated in a glass beaker. Any volatile constituents are condensed on either a cooled glass plate or a disc of cooled aluminium foil.

The fogging value  $F$  is calculated as the quotient, in percent, of the reflectometer value for the glass plate with fogging condensate and the reflectometer value of the same glass plate without fogging condensate.

The mass of the condensable constituents  $G$  is given by the difference between the masses of the aluminium foil disc with and without fogging.

## 4 Materials

**4.1 Thermal-transfer fluid**, for the thermostatically controlled bath (5.1). The fluid shall be temperature-stable and preferably water-soluble for easier cleaning. A suitable fluid is a modified polyhydric aliphatic alcohol.

**4.2 Glass-cleaning detergent**, of a non-alkaline type.

**4.3 Diisodecyl phthalate (DIDP)**, obtained from the stated source (see Annex C).

## 5 Apparatus

**5.1 Thermostatically controlled bath**, designed to operate at up to 130 °C. Safety devices shall be fitted to prevent overheating. The circulation system, the bath capacity and the heating system shall be such that the temperature can be kept constant to within  $\pm 0,5$  °C throughout the bath. The agitation of the bath shall be done at a slow and uniform speed.

NOTE 1 It is very important to keep the temperature correct, as tests have shown that only a 0,5 °C difference can be seen in the test results.

NOTE 2 Some heaters/circulators have a centrifugal pump in the bottom, pumping the liquid at high speed around the bath. The beakers (5.3) will then have the liquid passing them at different speeds and this will cause different temperatures in different beakers.

The bath shall be designed so that, after placing the beakers (5.3) in the bath, the temperature does not drop more than 5 °C, and the test temperature is regained after no more than 20 min. The minimum distance between the beakers and the walls shall be 30 mm and between the bottom of the bath and the beakers 60 mm.

The bath shall be equipped with a device indicating the distance between the bath fluid and the lower surface of the glass plate (5.6). This distance shall be  $(60 \pm 2)$  mm.

**5.2 Cooling plates**, designed to be placed on the glass plates (5.6) to keep them cool. The cooling plates shall be hollow and made of corrosion-resistant metal, with the side facing the glass plate made of aluminium. They shall have two cooling-water connections located so that the cooling water flows through the whole of the interior of the plate. The surface in contact with the glass plate shall be flat. The mass of a cooling plate filled with water shall be at least 1 kg, to overcome the buoyancy of the beaker (5.3) in the bath. The whole of the weight of the cooling plate shall rest on the beaker. A separate cooling plate shall be used for each beaker.

The cooling plates and the associated water thermostat shall be designed so that the mean water temperature is 21 °C and the difference in temperature between the inlet and outlet does not exceed 1 °C.

**5.3 Flat-bottomed beakers**, of heat-resistant glass, minimum mass 400 g, with the dimensions shown in Figure 1.

**5.4 Metal rings**, external diameter 80 mm, internal diameter 74 mm, height 10 mm and mass  $(55 \pm 1)$  g, made of corrosion-protected steel, to keep the test pieces flat.

**5.5 Sealing rings**, of silicone- or fluoro-rubber, L-shaped or circular in cross-section, inner diameter 90 mm to 95 mm, thickness 2 mm to 4 mm and hardness 50 IRHD to 70 IRHD.

**5.6 Float-glass plates**, of residential or windshield window quality, for condensation of the fogging, thickness  $(3 \pm 0,2)$  mm, either square with minimum dimensions of  $(110 \times 110)$  mm or circular with a diameter of 103 mm. The reflectometer values of all the plates used shall be the same to within  $\pm 2$  % units. The tin and non-tin surfaces of the plates shall be identified.

NOTE The tin and non-tin surfaces of the glass plates can be identified by viewing the surfaces in a darkened room under a UV light at 254 nm wavelength. The tin surface will fluoresce when it is exposed to the UV light.

Dimensions in millimetres

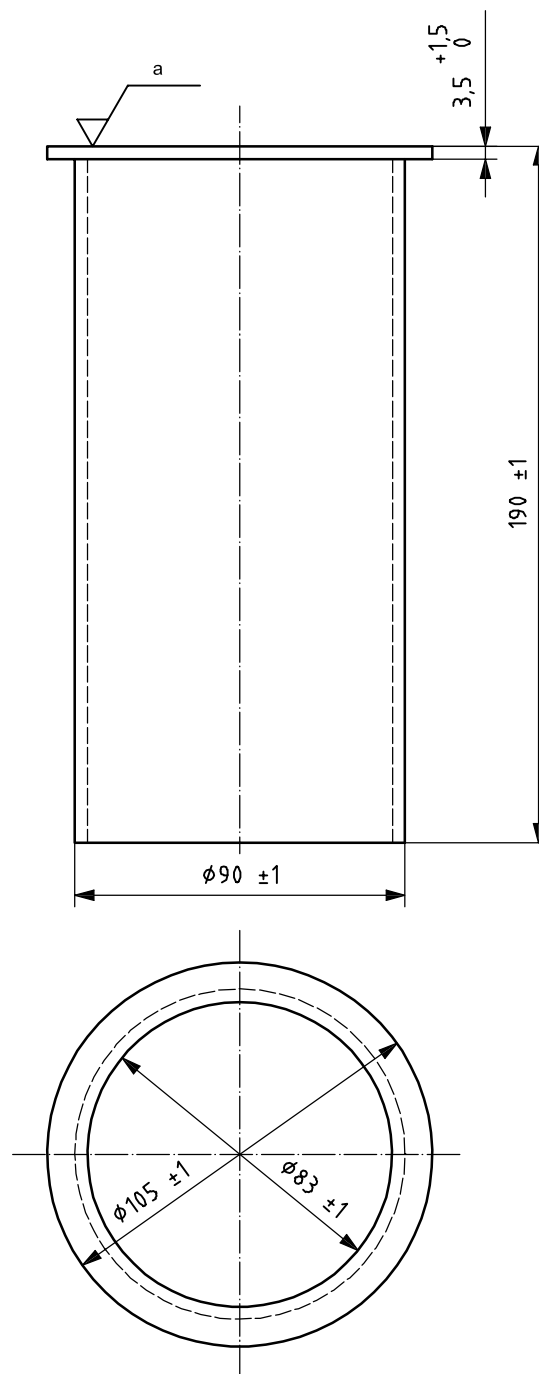

<sup>a</sup> Ground.

**Figure 1 — Glass beaker**

**5.7 Filter paper**, with a diameter of 110 mm and a mass per unit surface area of 90 g/m<sup>2</sup>.

**5.8 Aluminium foil discs**, thickness 0,03 mm, diameter  $(103 \pm 1)$  mm. Store the prepared aluminium foil discs in a desiccator (5.14) to avoid condensation and contamination.

**5.9 Reflectometer**, with a 60° incident beam and 60° measurement beam.

**5.10 Spacer**, designed to prevent contact with the condensate on the glass plate during reflectometer measurements, made of a suitable material such as paper or plastic with a circular hole for the measurements. The thickness of the spacer shall be  $(0,1 \pm 0,02)$  mm (see Figure 2).

Dimensions in millimetres

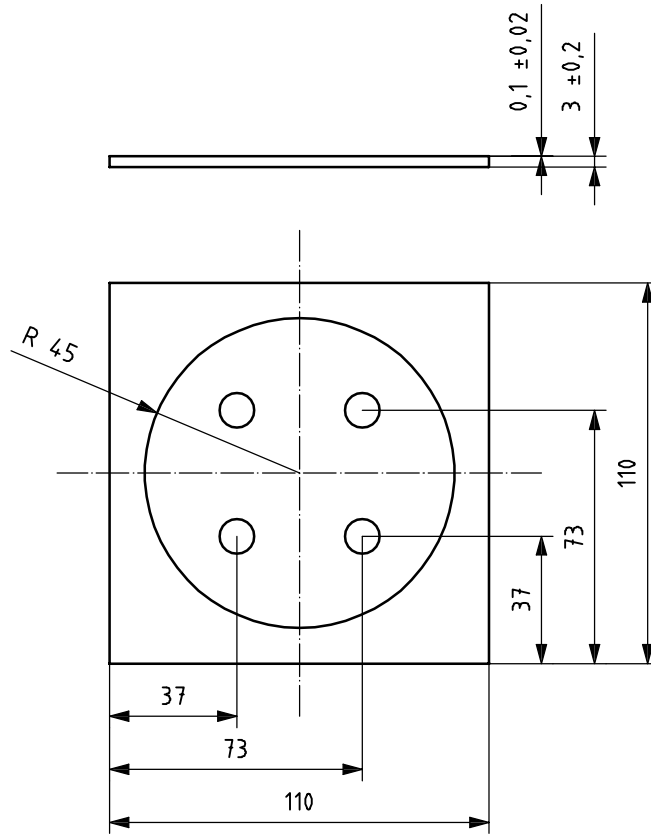

Figure 2 — Spacer on top of glass plate

**5.11 Dishwasher**, preferably connected to a deionized-water supply and capable of being operated at 80 °C.

**5.12 Balance**, with scale divisions of 0,01 mg.

**5.13 Polyethylene gloves**.

**5.14 Desiccator**, with suitable drying material.

## 6 Test pieces and test samples

In the case of finished products, cut circular test pieces with a diameter of  $(80 \pm 1)$  mm from the sample. The thickness of the test pieces can be up to 10 mm. Machine thicker materials on the underside to 10 mm (the underside is the side facing away from the side which is visible in the vehicle). If other test piece dimensions are required, these may be as given in the product specification or as agreed between the interested parties.

In the case of powdered, pasty or fluid materials, take a test sample of  $(10 \pm 0,1)$  g.

Take two test pieces or test samples for the determination of the fogging value  $F$  and another two for the determination of the mass of the condensable constituents  $G$ .



## 7 Conditioning

Unless otherwise specified, condition all test pieces and test samples at 23 °C and 50 % RH for at least 16 h.

Foamed materials and coated fabrics shall be conditioned by drying in accordance with Table 1 in a desiccator over phosphorus pentoxide (or silica gel) on a carrier, without the use of a vacuum.

**Table 1 — Drying times**

Material	Drying time days
Foamed materials	1
Coated fabrics	2
Materials with a high water content (e.g. leather)	7

## 8 Procedure

### 8.1 Cleaning

#### 8.1.1 General

Only touch the beakers (5.3) on the outer surfaces. Do not touch the glass plates (5.6) or the metal rings (5.4) with bare hands; use gloves (5.13) or tongs.

After the glass plates have been cleaned and dried, make a visual check that the plates are free of scratches and other defects; if they are not, discard them.

After cleaning, store all items, the beakers upside-down, in a dust-free environment at room temperature until the measurements are made.

#### 8.1.2 Cleaning with a dishwasher

Wash the sealing rings (5.5), beakers and metal rings twice in a dishwasher (5.11) with glass-cleaning detergent (4.2). If the dishwasher is not connected to a deionized-water supply, rinse the cleaned equipment in deionized water.

Prior to each use, clean all glass plates twice in the dishwasher at 80 °C using a glass-cleaning detergent. If the dishwasher is not connected to a deionized-water supply, rinse the cleaned glass plates in deionized water at room temperature and dry them in an upright position.

It is recommended that the glass plates are not reused more than a few times, since microscopic scratches may affect the rate of deposition of any vapours and hence the reproducibility of the method. Discard any glass plates that have surface scratches or abraded spots.

**NOTE** Tests have shown that it is very important to use a neutral or acid detergent as alkaline detergent affects the glass surface and the reflectometric fogging value increases.

### 8.2 Control tests

In parallel with every fogging test, carry out a control test to determine the fogging value  $F$  of the reference liquid DIDP. For this purpose, add  $(10 \pm 0,1)$  g of DIDP to a beaker, taking care not to moisten the inner wall of the beaker. Place the beaker with the DIDP in the bath (5.1), using a different position for each test. After the test period of  $(180 \pm 3)$  min at the bath temperature of  $(100 \pm 0,5)$  °C, the fogging value shall be within  $\pm 3$  % units of the value stated on the bottle. If this is not the case, check the test conditions.

Carry out the same procedure with DIDP when determining the mass of the condensable constituents  $G$ . After the test period of  $(16 \pm 0,2)$  h at the bath temperature of  $(100 \pm 0,5)$  °C, the mass of the condensable constituents shall be within  $\pm 0,25$  mg of the value stated on the bottle. If this is not the case, check the test conditions.

NOTE It is very important not to moisten the walls of the beaker with the DIDP when handling the beaker, as this will give a larger area with DIDP and a higher test result.

### 8.3 Arrangement of test pieces and test samples

Insert the test pieces into beakers (one test piece per beaker). Do not touch the test pieces with bare hands.

Place the test pieces so that the visible side, i.e. the side facing the vehicle interior, faces upwards. To prevent rolling and warping of the test pieces, place a metal ring on each.

When testing powdered, pasty or fluid materials, use a  $(10 \pm 0,1)$  g test sample, uniformly distributing it over the bottom of the inside of the beaker.

### 8.4 Measurements prior to the fogging test

When reflectometric values are to be determined, calibrate the reflectometer (5.9) in accordance with the manufacturer's operating instructions. For this purpose, place a glass plate, with the non-tin side up, on a matt-white filter paper backing and place a spacer on the glass plate. Make markings on the spacer for the edges of the reflectometer. Place the reflectometer against these markings. The measurement spots shall be at a distance of  $(25 \pm 5)$  mm from the centre of the glass plate. Take four readings  $R_{01}$  to  $R_{04}$  with the reflectometer aligned parallel to the plate edges (or the tangents to the plate edges in the case of circular plates), rotating the reflectometer by  $90^\circ$  between each reading.

Since the measured reflectometer values before and after the fogging test are to be linked in pairs, the measurement geometry must be the same in each case. The glass plates must therefore be marked so that they can be positioned in exactly the same way before and after the fogging test.

When the mass of the condensable constituents is to be determined, use aluminium foil discs. Use polyethylene gloves when handling the discs. Take care not to crease the discs. A recommended method of preparing the discs is to cut them out by stamping from several layers of aluminium foil alternating with layers of paper edge-welded to the foil. Take care to avoid contaminating the discs when cutting them out. Use the depression produced in the discs by the stamping procedure to give an improved seal with the sealing ring. Determine the mass  $G_0$  of each disc to  $\pm 0,02$  mg.

### 8.5 Fogging test

#### 8.5.1 Set-up

Place a sealing ring on top of each loaded beaker. For the determination of the fogging value  $F$ , place a clean glass plate, with its non-tin surface of known  $R_0$  value facing downwards, on top, covering the beaker. For the determination of the mass of the condensable constituents  $G$ , place a weighed aluminium disc (5.8), bright side downwards, on the sealing ring, followed by a clean glass plate.

Place the beakers prepared in this manner in the thermostatic bath held at  $(100 \pm 0,5)$  °C.

NOTE 1 Other temperatures may be agreed upon by the interested parties.

Place a filter paper (5.7) on each glass plate (to prevent scratching of the surface of the glass plate), followed by a cooling plate (5.2).

Set the temperature of the cooling water at  $(21 \pm 1)$  °C.

NOTE 2 Other temperatures may be agreed upon by the interested parties.

Ensure that the distance between the level of the bath fluid at the test temperature and the lower surface of each glass plate is  $(60 \pm 2)$  mm.

NOTE 3 When changing the test temperature, check the level as the volume of the liquid changes with temperature.

### 8.5.2 Determination of fogging value $F$

Keep the beakers in the thermostatic bath for a period of  $(180 \pm 3)$  min.

NOTE 1 Other periods may be agreed upon by the interested parties.

Then raise the glass plates without touching the fogging condensate and store in a horizontal position, with the fogging condensate upwards, in a dust- and draught-free atmosphere at  $(23 \pm 2)$  °C and  $(50 \pm 5)$  % RH. Do not expose the glass plates to direct sunlight.

Carry out the measurement of the reflectometer value after a storage period of  $(60 \pm 6)$  min.

NOTE 2 Other periods may be agreed upon by the interested parties.

Prior to measuring the fogging condensate with the reflectometer, check visually that the condensate does consist of droplets, and does not consist of a continuous film or contain crystals or other structural features. Do not measure reflectometer values of such condensates since they give misleading results. If such condensates are formed, mention this fact in the test report. If necessary, repeat the test.

Recalibrate the reflectometer. Then place the glass plate on the white filter paper backing, and the spacer on the glass plate.

Place the reflectometer over the guide markings and take four readings  $R_{11}$ ,  $R_{12}$ ,  $R_{13}$  and  $R_{14}$ .

Measure the reflectometer values for two test pieces. If the fogging values obtained deviate by more than 10 % from the mean value, test a further two test pieces and calculate the mean value of only those which are within  $\pm 10$  % of the mean.

### 8.5.3 Determination of mass of condensable constituents $G$

Allow the beakers to remain in the thermostatic bath for  $(16 \pm 0,1)$  h. After this period, carefully remove the aluminium discs, on their sealing rings, and store them with the fogged side up in a desiccator for 3,5 h to 4 h. Do not over-fill the desiccator. Do not expose the discs to direct sunlight in the desiccator. Determine the mass  $G_1$  of each fogged disc to within 0,01 mg.

Carry out measurements on two test pieces. If the masses of the condensable constituents deviate by more than 10 % from the mean value, test a further two test pieces and calculate the mean of the results obtained for all four test pieces.

## 9 Expression of results

To calculate the fogging value  $F$ , first calculate the fogging value  $F_j$  for each glass plate using the equation

$$F_j = \left( \frac{R_{11}}{R_{01}} + \frac{R_{12}}{R_{02}} + \frac{R_{13}}{R_{03}} + \frac{R_{14}}{R_{04}} \right) \times \frac{100}{4}$$

where

$F_j$  is the fogging value for the  $j$ th plate, in %;

$R_{11}$  to  $R_{14}$  are the reflectometer readings for the fogged plate, in %;

$R_{01}$  to  $R_{04}$  are the reflectometer readings for the unfogged plate, in %.



## Annex A (informative)

### Precision results

#### A.1 General

The precision calculations to express repeatability and reproducibility were performed in accordance with ISO/TR 9272. Consult this for precision concepts and nomenclature. Annex B gives guidance on the use of repeatability and reproducibility results.

#### A.2 Precision details

An interlaboratory test programme was conducted in the USA in 1989 using the method given in ASTM D 5393 (equivalent to this International Standard). Four materials were tested by seven laboratories. For each material, all the samples were prepared by a single source, but the individual test pieces were prepared at the laboratories that tested them. Each test result was the average of three individual determinations. Each laboratory obtained three test results for each material.

#### A.3 Precision results

The precision results for all tests are given in Table A.1. See Annex B for guidance on using precision results.

**Table A.1 — Precision results**

Material	Within-laboratory ( <i>r</i> )	Between-laboratory ( <i>R</i> )
DIDP (1)	11,14	19,88
Grey body cloth	18,90	60,39
DIDP (2)	7,53	17,64
Brown vinyl	18,48	69,72
Average	14,00	41,90
( <i>r</i> ) is the repeatability, expressed as a percentage of the average for the material;		
( <i>R</i> ) is the reproducibility, expressed as a percentage of the average for the material.		

## Annex B (informative)

### Guidance on using precision results

**B.1** The general procedure for using precision results is as follows, with the symbol  $|x_1 - x_2|$  designating a positive difference in any two measurement values (i.e. without regard to sign).

**B.2** Enter the appropriate precision table (for whatever test parameter is being considered) at an average value (of the measured parameter) nearest to the “test” data average under consideration. This line will give the applicable  $r$ , ( $r$ ),  $R$  or ( $R$ ) for use in the decision process.

**B.3** With these  $r$  and ( $r$ ) values, the following general repeatability statements may be used to make decisions.

**B.3.1** For an absolute difference:

The difference  $|x_1 - x_2|$  between two test (value) averages, found on nominally identical material samples under normal and correct operation of the test procedure, will exceed the tabulated repeatability  $r$  on average not more than once in twenty cases.

**B.3.2** For a percentage difference between two test (value) averages:

The percentage difference

$$\left[ |x_1 - x_2| / |x_1 + x_2| / 2 \right] \times 100$$

between two test values, found on nominally identical material samples under normal and correct operation of the test procedure, will exceed the tabulated repeatability ( $r$ ) on average not more than once in twenty cases.

**B.4** With these  $R$  and ( $R$ ) values, the following general reproducibility statements may be used to make decisions.

**B.4.1** For an absolute difference:

The absolute difference  $|x_1 - x_2|$  between two independently measured test (value) averages, found in two laboratories using normal and correct test procedures on nominally identical material samples, will exceed the tabulated reproducibility  $R$  not more than once in twenty cases.

**B.4.2** For a percentage difference between two test (value) averages:

The percentage difference

$$\left[ |x_1 - x_2| / |x_1 + x_2| / 2 \right] \times 100$$

between two independently measured test (value) averages, found in two laboratories using normal and correct test procedures on nominally identical material samples, will exceed the tabulated reproducibility ( $R$ ) not more than once in twenty cases.

**Annex C**  
(normative)

**DIDP reference liquid**

DIDP reference liquid shall be obtained from:

SP Technical Research Institute of Sweden  
Chemistry and Materials Technology  
Box 857  
SE-501 15 Borås  
Sweden  
Fax: +46 33 10 33 88  
E-mail: info@sp.se

## Bibliography

- [1] ASTM D 5393, *Test Method for Determination of Fogging Characteristics of Vehicle Interior Trim Materials* (now withdrawn)



This page is intentionally blank.

This page is intentionally blank.

This page is intentionally blank.

