

INTERNATIONAL STANDARD

ISO 6433

Second edition
2012-05-15

Technical product documentation — Part references

Documentation technique de produits — Références de pièce



Reference number
ISO 6433:2012(E)

© ISO 2012

ISO 6433:2012(E)



COPYRIGHT PROTECTED DOCUMENT

© ISO 2012

All rights reserved. Unless otherwise specified, no part of this publication may be reproduced or utilized in any form or by any means, electronic or mechanical, including photocopying and microfilm, without permission in writing from either ISO at the address below or ISO's member body in the country of the requester.

ISO copyright office
Case postale 56 • CH-1211 Geneva 20
Tel. + 41 22 749 01 11
Fax + 41 22 749 09 47
E-mail copyright@iso.org
Web www.iso.org

Published in Switzerland

Foreword

ISO (the International Organization for Standardization) is a worldwide federation of national standards bodies (ISO member bodies). The work of preparing International Standards is normally carried out through ISO technical committees. Each member body interested in a subject for which a technical committee has been established has the right to be represented on that committee. International organizations, governmental and non-governmental, in liaison with ISO, also take part in the work. ISO collaborates closely with the International Electrotechnical Commission (IEC) on all matters of electrotechnical standardization.

International Standards are drafted in accordance with the rules given in the ISO/IEC Directives, Part 2.

The main task of technical committees is to prepare International Standards. Draft International Standards adopted by the technical committees are circulated to the member bodies for voting. Publication as an International Standard requires approval by at least 75 % of the member bodies casting a vote.

Attention is drawn to the possibility that some of the elements of this document may be the subject of patent rights. ISO shall not be held responsible for identifying any or all such patent rights.

ISO 6433 was prepared by Technical Committee ISO/TC 10, *Technical production documentation*, Subcommittee SC 1, *Basic conventions*.

This second edition cancels and replaces the first edition (ISO 6433:1981), which has been technically revised.

Technical product documentation — Part references

1 Scope

This International Standard gives rules for the presentation of part references in assembly representations, e.g. on assembly drawings, in order to identify the constituent parts in a related parts list.

2 Normative references

The following referenced documents are indispensable for the application of this document. For dated references, only the edition cited applies. For undated references, the latest edition of the referenced document (including any amendments) applies.

ISO 128-22:1999, *Technical drawings — General principles of presentation — Part 22: Basic conventions and applications for leader lines and reference lines*

ISO 128-23:1999, *Technical drawings — General principles of presentation — Part 23: Lines on construction drawings*

ISO 128-24:1999, *Technical drawings — General principles of presentation — Part 24: Lines on mechanical engineering drawings*

ISO 128-25:1999, *Technical drawings — General principles of presentation — Part 25: Lines on shipbuilding drawings*

ISO 129-1:2004, *Technical drawings — Indication of dimensions and tolerances — Part 1: General principles*

ISO 3098-0:1997, *Technical product documentation — Lettering — Part 0: General requirements*

ISO 7573:2008, *Technical product documentation — Parts lists*

3 General requirements

It is recommended that part references be assigned in sequential order (see 4.7).

Identical parts shown in an assembly shall have the same part reference.

Each complete sub-assembly incorporated in the superior assembly is identified by a single part reference.

All part references shall be shown in a parts list (see ISO 7573) giving the appropriate information on the parts concerned.

4 Presentation

4.1 Identifiers

Preferably part references should consist of numerals only. If necessary, they may be augmented by the use of capital letters. The design, dimensions and spacing of the characters shall comply with ISO 3098-0.

It is recommended that the part reference number contain a maximum of three characters.

ISO 6433:2012(E)

4.2 Appearance

All part references on the same drawing shall be of the same type and have the same height of lettering. They shall be clearly distinguishable from all other indications. This can be achieved for example by:

- a) encircling the characters of each part reference (see Figure 1); in this case, the circles shall have the same diameter and be drawn with continuous narrow lines (type 01.1 of ISO 128-23, ISO 128-24 and ISO 128-25);

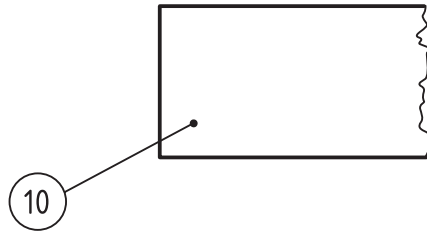

Figure 1 — Encircled-part reference number

- b) using characters of a larger height, for example twice the height as used for dimensioning, and similar indications (see Figures 2 and 3).

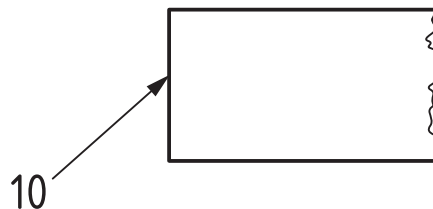

Figure 2 — Part reference number written with larger character height

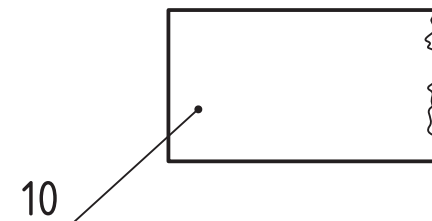

Figure 3 — Alternative method of indication

4.3 Identical parts

Part references of identical parts should only be identified once, provided that there is no risk of ambiguity. For exceptions, see Annex A.

4.4 Location

Part references shall be placed outside the outlines of the parts concerned.

The part reference should be connected to its associated part by a leader line (see Figures 1, 2 and 3), the termination of which shall comply with ISO 128-22.

Leader lines shall not intersect. They should be kept as short as practicable and should preferably be drawn at an angle to the part reference. In the case of encircled-part references, the leader line shall be directed towards the centre of the circle.

4.5 Positioning

For the sake of clarity and legibility of a drawing, part references should preferably be arranged in horizontal rows and/or vertical columns (see Figure 4).

When several part references use a common leader line, they may be arranged horizontally according to one of following methods illustrating four part references (8, 9, 10 and 11).

NOTE Method a) can also be arranged vertically.

Methods:

a) 

b) 8-9-10-11

4.6 Related parts

Part references of related parts, e.g. screw, washer and nut, may be identified by a common leader line (see Figure 4, parts 2, 3 and 4).

4.7 Numbering sequence

A distinct sequence for numbering should be adopted:

- according to the possible order of assembly;
- according to the importance of the component parts (sub-assemblies, major parts, minor parts, etc.);
- according to any other logical sequence.

5 Example

An example of the application of part references for an assembly is given in Figure 4.

ISO 6433:2012(E)

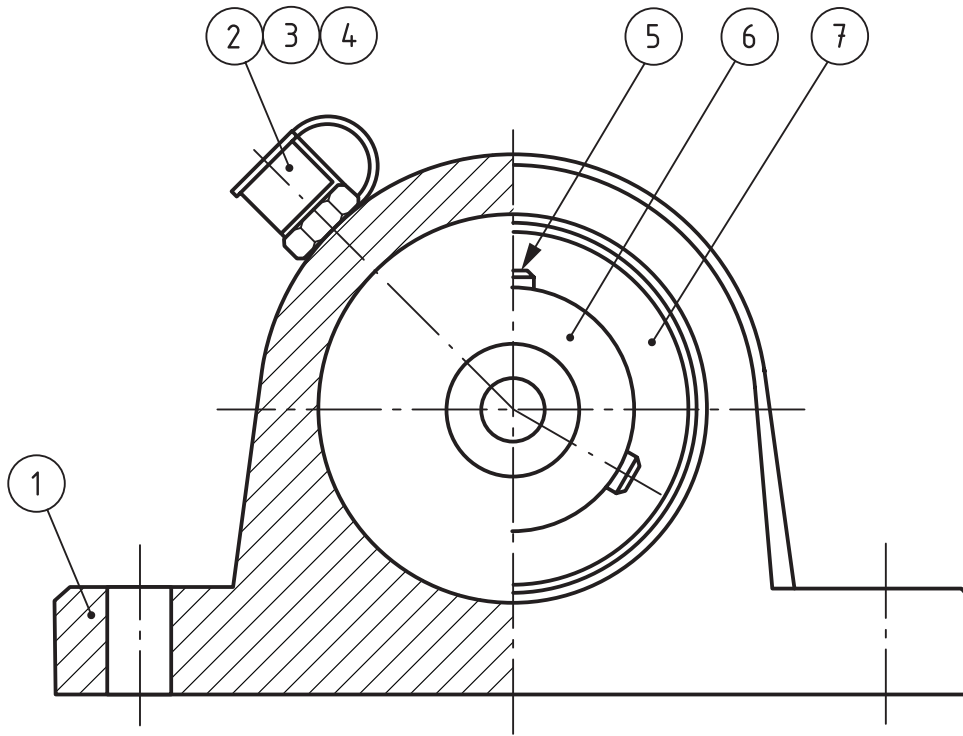

Figure 4 — Use of part references on an assembly drawing

Annex A (normative)

Part references shown with number of parts

The number of parts is specified in the parts list and should be avoided in connection to the part reference number on the drawing.

For clarity, the same part reference number may need to be repeated at different locations. The number of parts at each location may also be needed. The part reference number shall then be encircled according to method a) in 4.2 and the indication of number of parts should follow general drawing rules. The number of parts shall be indicated along with the symbol "x" in accordance with ISO 129-1. See Figure A.1.

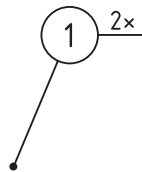
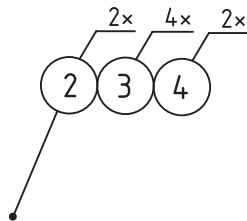
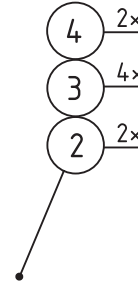

Figure A.1 — Part reference shown with number of parts

When the number of parts is indicated for several part references using a common leader line, method a) in 4.5 shall be used. See Figure A.2.



Example 1



Example 2

Figure A.2 — Indication of number of parts for several part references with common leader line

ISO 6433:2012(E)

ICS 01.110.00

Price based on 5 pages