

# INTERNATIONAL STANDARD

**ISO  
6413**

First edition  
1988-12-01



---

INTERNATIONAL ORGANIZATION FOR STANDARDIZATION  
ORGANISATION INTERNATIONALE DE NORMALISATION  
МЕЖДУНАРОДНАЯ ОРГАНИЗАЦИЯ ПО СТАНДАРТИЗАЦИИ

---

## **Technical drawings — Representation of splines and serrations**

*Dessins techniques — Représentation des cannelures et des dentelures*

Reference number  
ISO 6413 : 1988 (E)

## Foreword

ISO (the International Organization for Standardization) is a worldwide federation of national standards bodies (ISO member bodies). The work of preparing International Standards is normally carried out through ISO technical committees. Each member body interested in a subject for which a technical committee has been established has the right to be represented on that committee. International organizations, governmental and non-governmental, in liaison with ISO, also take part in the work. ISO collaborates closely with the International Electrotechnical Commission (IEC) on all matters of electrotechnical standardization.

Draft International Standards adopted by the technical committees are circulated to the member bodies for approval before their acceptance as International Standards by the ISO Council. They are approved in accordance with ISO procedures requiring at least 75 % approval by the member bodies voting.

International Standard ISO 6413 was prepared by Technical Committee ISO/TC 10, *Technical drawings*.

Annex A forms an integral part of this International Standard.

# Technical drawings — Representation of splines and serrations

## 1 Scope

This International Standard specifies the rules and graphical symbols for the representations of splines and serrations on technical drawings.

Two methods of representation are specified as follows :

- a) true representation;
- b) simplified representation.

The rules and graphical symbols specified in this International Standard are applicable to detail drawings of the parts (shafts and hubs) and to assembly drawings of joints.

NOTE — For uniformity all figures in this International Standard are drawn in the first-angle orthographic projection.

It should be understood that the third-angle orthographic projection could equally well have been used without prejudice to the principles established.

## 2 Normative references

The following standards contain provisions which, through reference in this text, constitute provisions of this International Standard. At the time of publication, the editions indicated were valid. All standards are subject to revision, and parties to agreements based on this International Standard are encouraged to investigate the possibility of applying the most recent editions of the standards listed below. Members of IEC and ISO maintain registers of currently valid International Standards.

ISO 14 : 1982, *Straight-sided splines for cylindrical shafts with internal centering — Dimensions, tolerances and verification.*

ISO 128 : 1982, *Technical drawings — General principles of presentation.*

ISO 3098-1 : 1974, *Technical drawings — Lettering — Part 1 : Currently used characters.*

ISO 3461-2 : 1987, *General principles for the creation of graphical symbols — Part 2 : Graphical symbols for use in technical product documentation.*

ISO 4156 : 1981, *Straight cylindrical involute splines — Metric module, side fit — Generalities, dimensions and inspection.*

## 3 Definitions

For the purposes of this International Standard, the following definitions apply.

**3.1 spline joint** : Connecting, co-axial, elements that transmit torque through the simultaneous engagement of equally spaced teeth situated around the periphery of a cylindrical external member with similar spaced mating spaces situated around the inner surface of the related cylindrical internal member. [ISO 4156 : 1981]

**3.2 involute spline** : One member of a spline joint having teeth or spaces that have involute flank profiles. [ISO 4156 : 1981]

**3.3 straight-sided spline** : One member of a spline joint having teeth or spaces that have straight-sided flank profiles.

**3.4 serration** : One member of a spline joint having teeth or spaces that generally have flank profiles of 60° pressure angle.

## 4 Designation

The designation of spline joints shall consist of the graphical symbol of the type and the designation of joint specified in the relevant International Standard (see clause 2) or any other standard dealing with this subject.

### 4.1 Graphical symbols

The type of spline joint is indicated by graphical symbols.

The graphical symbols for the straight-sided spline (see ISO 14) are shown in figure 1 and for the involute spline (see ISO 4156) and for serrations are shown in figure 2.



Figure 1



Figure 2

The proportion and dimensions of the graphical symbols are specified in annex A.

## 4.2 Method for indicating designation

The designation should be indicated near the feature but always connected to the contour of the spline joint by a leader line (see figure 3).

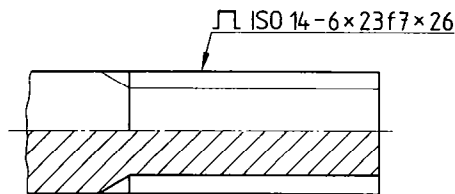

Figure 3

Where a spline joint is not in accordance with a standard as mentioned above, or where the requirement is modified, the necessary data shall be tabulated on the drawing or any other associated document and shall be cross-referenced by a leader line and graphical symbol to the applicable contour.

## 5 Complete representation of spline joints

A complete representation of spline joints showing all details with their true dimensions is generally not necessary in a technical drawing and should be avoided.

If such a representation has to be made, the drawing rules laid down in ISO 128 shall be applied.

If necessary, a designation of the spline joint in accordance with clause 4 may be added.

Figure 4 shows an example of a complete representation of a straight-sided spline joint.

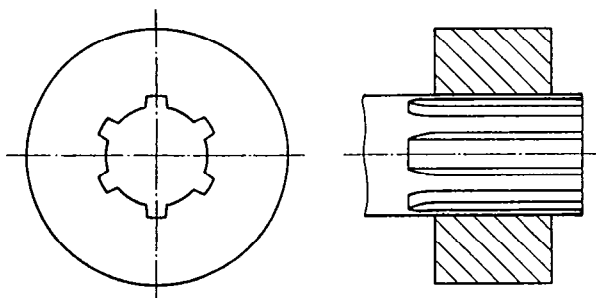

Figure 4

Figure 5 shows an example of a complete representation of an involute spline joint.

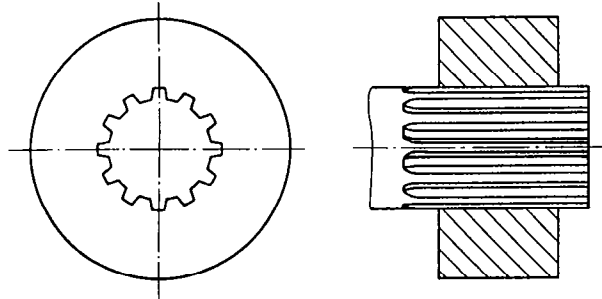

Figure 5

Figure 6 shows an example of a complete representation of a serration.

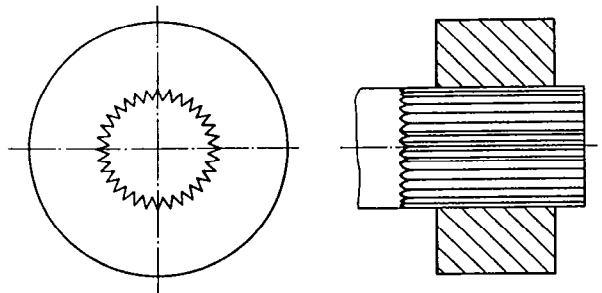

Figure 6

## 6 Simplified representation

### 6.1 General

A simplified representation for straight-sided splines and for involute splines as shown in table 1 is usually adequate to convey all the necessary information.

Table 1 – Simplified representation

	Straight-sided splines	Involute splines and serrations
Shaft		
Hub		
Spline joint		

1) If necessary, the designation of the spline joint in accordance with clause 4 shall be added (for examples, see figures 13 and 14).

**6.2 Representation of details (shafts and hubs)**

As a fundamental principle, the parts of a spline joint shall be represented as a solid part without teeth, but with the addition of the root surface in a continuous thin line (see ISO 128, line type B) or the pitch surface in a thin chain line (see ISO 128, line type G).

**6.2.1 Contours and edges**

The contours and edges of a shaft (e.g. an external spline) or a hub (e.g. an internal spline) shall be drawn as if they were

- in an unsectioned view, solid parts (without teeth) bounded by a cylinder representing the tip surface (outside

diameter, for example, of an external spline or inside diameter, for example, of an internal spline);

- in an axial section, a shaft or hub having two diametrically opposed teeth (shown unsectioned), regardless of tooth spacing.

**6.2.2 Root surface**

For straight-sided splines, the root surface (minor diameter of external splined part, major diameter of internal spline) shall be drawn with a continuous thin line (see ISO 128, line type B).

In the axial section of a splined shaft or hub, however, the root surface shall be drawn with a continuous thick line (see ISO 128, line type A) in accordance with table 1.

**6.2.3 Pitch surface**

The pitch surface (pitch diameter) shall be drawn with a thin chain line (see ISO 128, line type G) for involute splines and serrations.

**6.2.4 Usable length**

The usable length of the splined part shall be represented with a continuous thick line (see ISO 128, line type A) (see figure 7).

Usually, only the usable length of a splined part shall be drawn.

**6.2.5 Tool run-out**

If necessary, the tool run-out may be represented by an oblique line or a radius with the same line as used for the root surface (see figures 7 and 8).

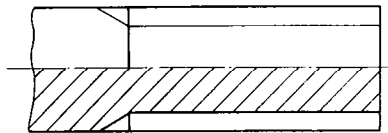

Figure 7



Figure 8

**6.2.6 Position of teeth**

If it is essential to indicate the position of the teeth in relation to a given axial plane, one or two teeth may be drawn with a continuous thick line (see ISO 128, line type A) (see figure 9).

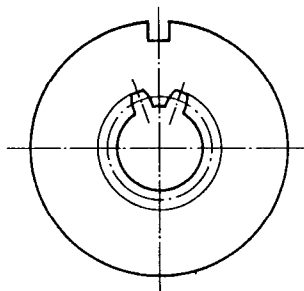

Figure 9

**6.2.7 Detailed drawing of tooth profile**

If the designation is not sufficiently clear, a detailed drawing of the tooth profile should be added (see figure 10).

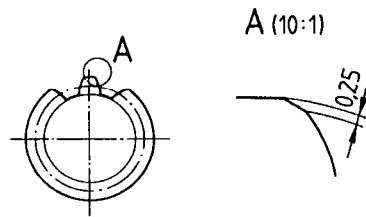

Figure 10

**6.2.8 Surface texture**

If it is necessary to specify the surface texture of the contacting surfaces (excluding root and tip diameter), the graphical symbol, the designation and the drawing indications used for surface texture should be indicated on a common leader line as shown in figure 11.

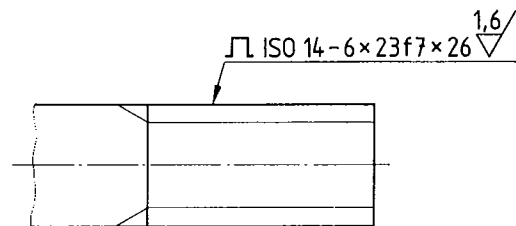

Figure 11

**7 Assembly drawings**

The rules specified for the representation of details are also applicable to assembly drawings (see figure 12).

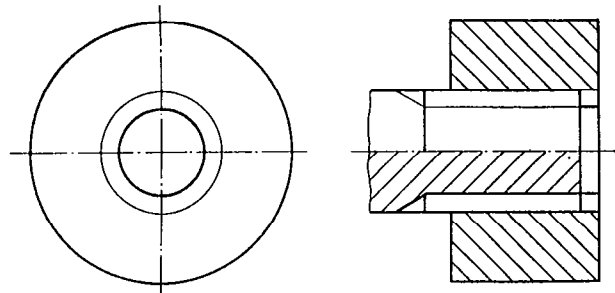

Figure 12

In assembly drawings, the designations of both parts (hub and shaft) shall be combined as shown in figures 13 and 14.

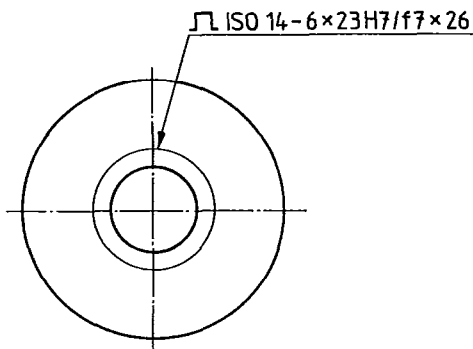

Figure 13

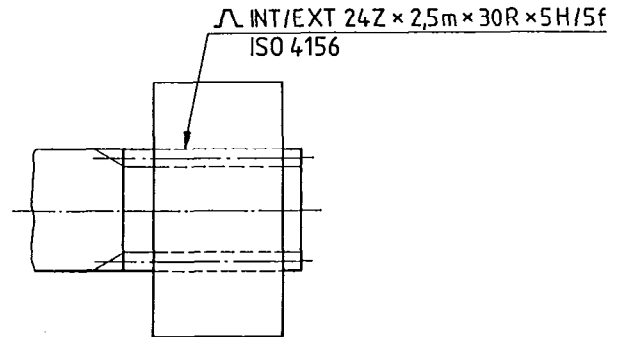

Figure 14

## Annex A (normative)

### Proportions and dimensions of graphical symbols

In order to harmonize the sizes of the graphical symbols specified in this International Standard with those of the other drawing indications, the following rules, in accordance with ISO 3461-2, shall be applied.

#### A.1 General requirements

**A.1.1** The graphical symbols shown in clause 4 shall be indicated using a line thickness  $d'$  equal to one-tenth of the height  $h$  of the lettering used for the dimensions in the relevant drawing.

**A.1.2** The numerals and letters used for the additional specifications shall be drawn using the same line thickness  $d$ , height  $h$  and type of lettering as used for dimensions in the relevant drawing, and in accordance with ISO 3098-1 (lettering type B, vertical).

#### A.2 Proportions

The graphical symbols shall be drawn in accordance with figures A.1 and A.2.

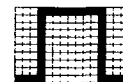

Figure A.1



Figure A.2

#### A.3 Dimensions

The range of sizes to be used for the graphical symbols and additional specifications are given in table A.1.

Table A.1 — Dimensions

Dimensions in millimetres

Height of numerals and letters, $h$	3,5	5	7	10	14	20
Line thickness for symbols, $d'$ , and lettering, $d$	0,35	0,5	0,7	1	1,4	2
Height of symbol, $h'$	3,5	5	7	10	14	20

**ISO 6413 : 1988 (E)**

.....

---

**UDC 744.4 : 621-45**

**Descriptors** : drawings, technical drawings, splines, graphic methods.

Price based on 5 pages

---