

INTERNATIONAL STANDARD

ISO 6412-2

First edition
1989-10-15

Technical drawings — Simplified representation of pipelines —

Part 2 : Isometric projection

*Dessins techniques — Représentation simplifiée des tuyaux et lignes de tuyauteries —
Partie 2 : Projection isométrique*



Reference number
ISO 6412-2 : 1989 (E)

Foreword

ISO (the International Organization for Standardization) is a worldwide federation of national standards bodies (ISO member bodies). The work of preparing International Standards is normally carried out through ISO technical committees. Each member body interested in a subject for which a technical committee has been established has the right to be represented on that committee. International organizations, governmental and non-governmental, in liaison with ISO, also take part in the work. ISO collaborates closely with the International Electrotechnical Commission (IEC) on all matters of electrotechnical standardization.

Draft International Standards adopted by the technical committees are circulated to the member bodies for approval before their acceptance as International Standards by the ISO Council. They are approved in accordance with ISO procedures requiring at least 75 % approval by the member bodies voting.

International Standard ISO 6412-2 was prepared by Technical Committee ISO/TC 10, *Technical drawings*.

ISO 6412 consists of the following parts, under the general title *Technical drawings — Simplified representation of pipelines*:

- *Part 1: General rules and orthogonal representation*
- *Part 2: Isometric projection*

Annex A of this part of ISO 6412 is for information only.

© ISO 1989

All rights reserved. No part of this publication may be reproduced or utilized in any form or by any means, electronic or mechanical, including photocopying and microfilm, without permission in writing from the publisher.

International Organization for Standardization
Case postale 56 • CH-1211 Genève 20 • Switzerland

Printed in Switzerland

Introduction

For drawings for tender, manufacturing drawings and erection drawings in pipeline construction as well as in machine construction and the construction industry, isometric projection has been introduced to a great extent, since the drawing work can be cut down and the presentation made clearer.

For the purposes of this part of ISO 6412, all dimensions and tolerances on the drawings have been stencilled in upright lettering. It should be understood that these indications could just as well be written in free-hand or inclined (italic) lettering without altering the meaning of the indications.

For the presentation of lettering (proportions and dimensions), see ISO 6412-1.

Technical drawings — Simplified representation of pipelines —

Part 2 : Isometric projection

1 Scope

This part of ISO 6412 specifies supplementary rules, in addition to the general rules given in ISO 6412-1, applicable to isometric representation. Isometric representation shall be used where the essential features are to be shown clearly in three dimensions.

2 Normative references

The following standards contain provisions which, through reference in this text, constitute provisions of this part of ISO 6412. At the time of publication, the editions indicated were valid. All standards are subject to revision, and parties to agreements based on this part of ISO 6412 are encouraged to investigate the possibility of applying the most recent editions of the standards listed below. Members of IEC and ISO maintain registers of currently valid International Standards.

ISO 128 : 1982, *Technical drawings — General principles of presentation*.

ISO 129 : 1985, *Technical drawings — Dimensioning — General principles, definitions, methods of execution and special indications*.

ISO 5261 : 1981, *Technical drawings for structural metal work*.

ISO 6412-1 : 1989, *Technical drawings — Simplified representation of pipelines — Part 1: General rules and orthogonal representation*.

3 Definitions

For the purposes of this part of ISO 6412, the definitions given in ISO 6412-1 apply.

4 Coordinates

As far as it is necessary to use Cartesian coordinates, for instance for calculations or numerical control of machine tools, the coordinate axes shall comply with figure 1.

In all cases, the coordinates of individual pipes or pipe assemblies should comply with those adopted for the complete installation and shall be indicated on the drawing or in an associated document.

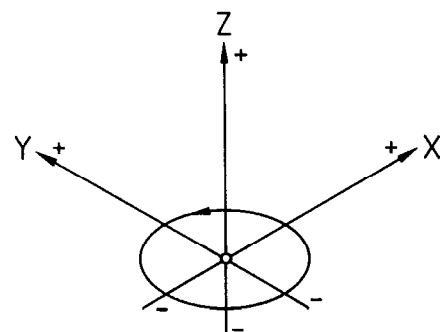

Figure 1

5 Line conventions

See ISO 6412-1.

6 Deviations from the direction of coordinate axes

6.1 General

Pipes, or parts of pipes, running parallel to the coordinate axes, shall be drawn parallel to the relevant axis without any further indication.

Deviations from the directions of the coordinate axes should be indicated by means of auxiliary hatched projection planes as shown in figure 2.

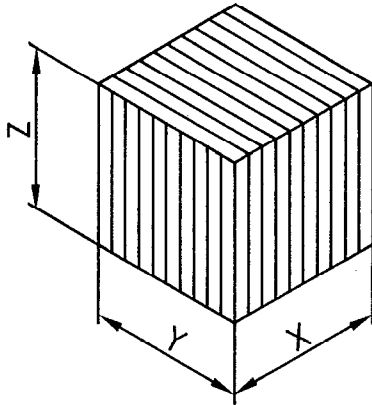

Figure 2

6.2 Pipes in a vertical plane

Pipes, or parts of pipes, situated in a vertical plane, shall be indicated by showing their projections on a horizontal plane [see figure 3a)].

6.3 Pipes in a horizontal plane

Pipes, or parts of pipes, situated in a horizontal plane, shall be indicated by showing their projections on a vertical plane [see figure 3b)].

6.4 Pipes not parallel to any coordinate plane

Pipes, or parts of pipes, not running parallel to any coordinate plane, shall be indicated by showing both their projections on a horizontal and on a vertical plane [see figure 3c)].

6.5 Auxiliary projection planes

It is recommended that the right angles of the triangles limiting the auxiliary projection planes be indicated.

Auxiliary projection planes may be emphasized by hatchings, parallel to the X- or Y-axis for horizontal auxiliary planes, and vertical for all other auxiliary planes.

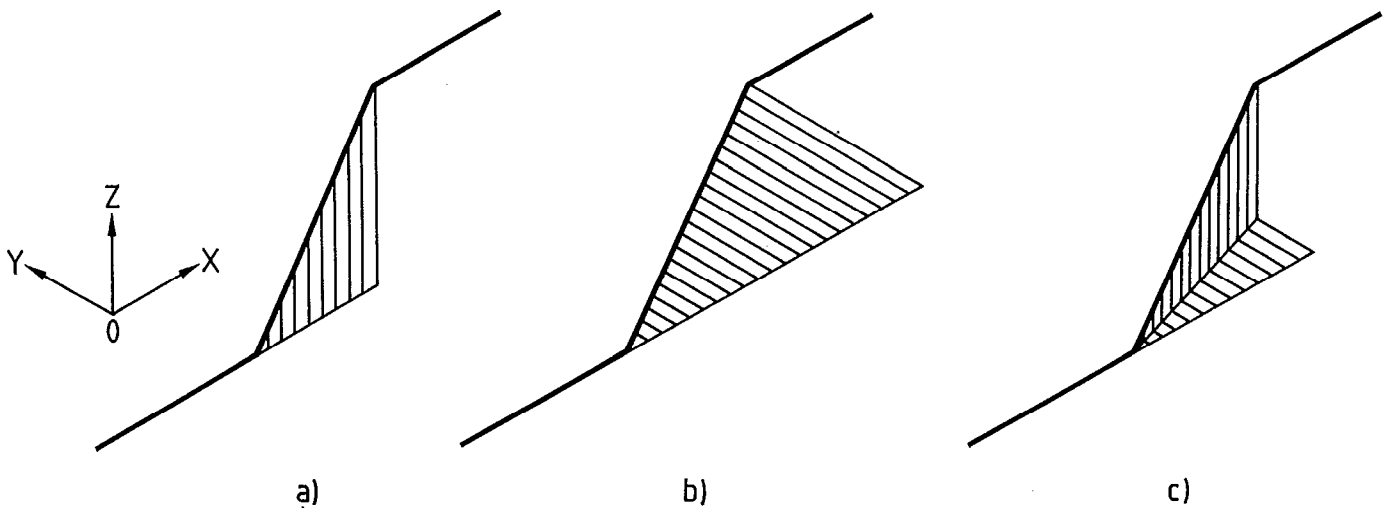

Figure 3

If such hatching is not convenient it may be omitted, but in that case the rectangle (see figure 4) or the rectangular prism (see figure 5), of which a diagonal coincides with the pipe, should be shown, using continuous thin lines (type B, ISO 128).

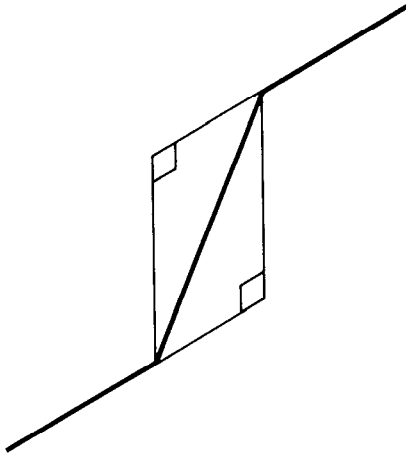

Figure 4

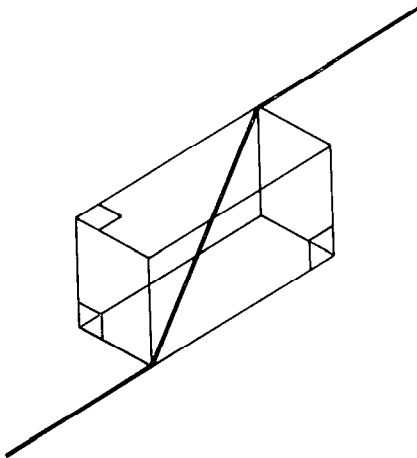

Figure 5

7 Dimensioning and special rules

7.1 General

Drawings shall be dimensioned in accordance with ISO 129. There are, however, special rules for isometric projection for pipelines which are specified in 7.2 to 7.10.

7.2 Diameters and wall thickness

The outer diameter (d) and the wall thickness (t) of pipes may be indicated in accordance with ISO 5261 (see figure 6). Nominal dimensions may be indicated in accordance with ISO 3545 using the short designation "DN" (see ISO 6412-1 : 1989, figure 1).

7.3 Longitudinal and angular dimensions

Longitudinal and angular dimensions should be indicated in accordance with ISO 129; the length shall start from the outer faces of the pipe ends, flanges, or centre of the joint, whenever appropriate.

7.4 Pipes with bends

Pipes with bends shall be dimensioned from central line to central line or from the central line to the end of the pipe (see figure 6).

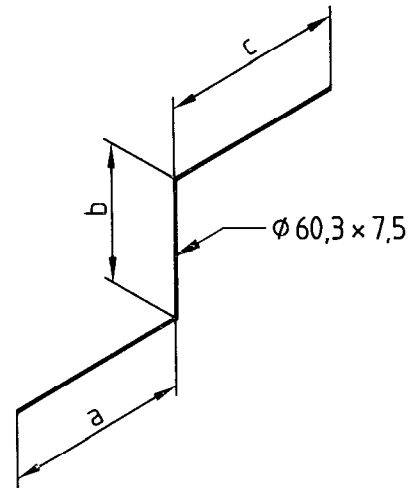

Figure 6

7.5 Radii and angles of bends

Radii and angles of bends may be indicated as shown in figure 7.

The functional angle shall be indicated.

NOTE — Bends may be simplified by extending the straight length of the flow line to the vertex. However, the actual bends in the pipes may be shown for sake of clarity. In this case, if projections of bends would otherwise have been elliptical, these projections may be simplified by drafting circular arcs.

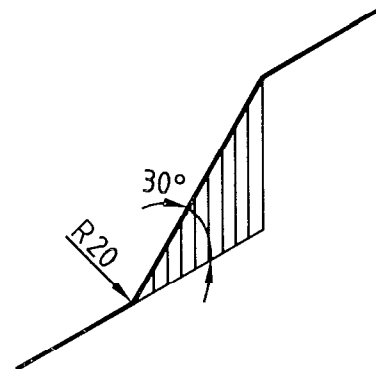

Figure 7

7.6 Levels

Levels should be indicated in accordance with ISO 129 and ISO 6412-1 (see figure 8).

The horizontal part of the leader line shall follow the direction of the associated flow line.

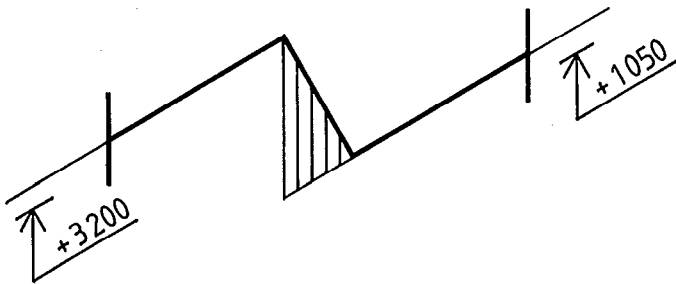

Figure 8

7.7 Direction of slope

The direction of slope shall be indicated by a right-angled triangle above the flow line, pointing from the higher down to the lower level, without changing the isometric direction of the flow line.

The amount of slope shall be indicated in accordance with the method shown in figure 9 and in ISO 6412-1.

It may, however, be useful to specify the slope be referring to a datum level (see figure 9).

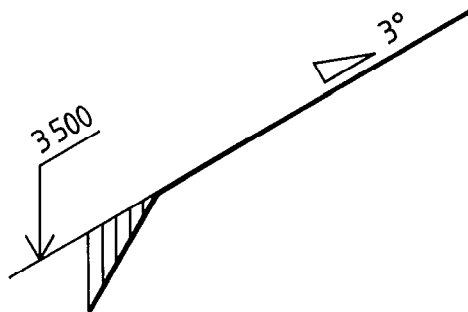

Figure 9

7.8 Positions of ends of pipes

If necessary, the positions of the ends of the piping may be specified by indicating the coordinates referring to the centres of the end faces.

In the case of adjacent drawings, a reference should be given. For example, "continued on drawing x".

7.9 Redundant dimensioning

If necessary, the auxiliary hatched projection planes can be dimensioned (see figure 10).

If it is necessary for manufacturing and/or technical reasons to indicate double dimensioning, one of the dimensions should be indicated in parentheses.

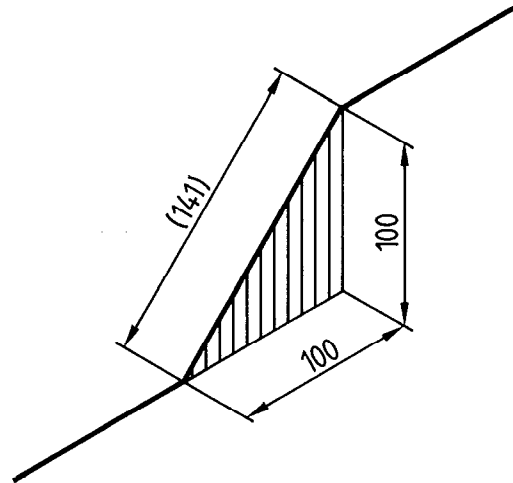

Figure 10

7.10 Dimensioning for pipe-bending machines

The dimensioning is defined on the basis of a reference system (point of origin) (see figure 23).

8 Graphical symbols

8.1 General

Graphical symbols for pipeline systems shall be in accordance with the International Standards given in clause 2 and in annex A and shall be drawn using the isometric projection method (see figure 11).

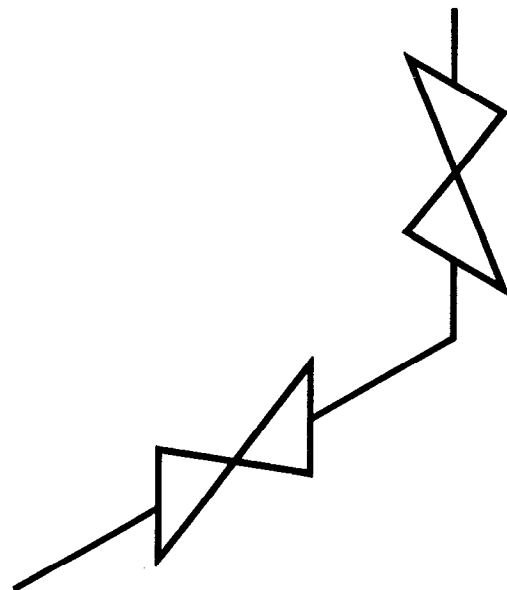

Figure 11

8.2 Examples of graphical symbols drawn with the isometric projection method

8.2.1 Valves

See examples in figures 12 and 13.

NOTE — Valve actuators should only be shown if it is necessary to define their positions or the kind of actuators (spindle, piston, etc.).

If shown, an actuator with a position parallel to one of the coordinate axes need not be dimensioned. Deviations from such positions should be indicated (see figure 13).

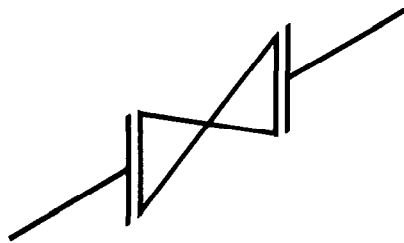

Figure 12

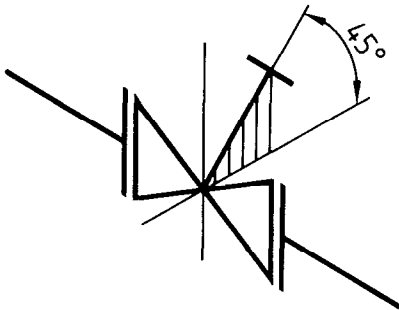

Figure 13

8.2.2 Transition pieces (cones)

The relevant nominal sizes shall be indicated above the graphical symbols (see figure 14).

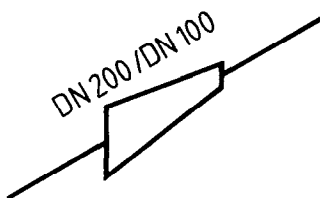

Figure 14

8.2.3 Supports and hangers

See examples in figures 15 and 16. See also ISO 6412-1 : 1989, 6.3.

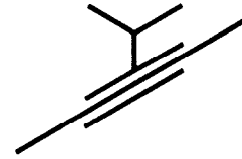

Figure 15

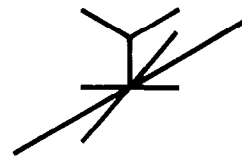

Figure 16

8.2.4 Crossings

Crossings shall be shown in accordance with ISO 6412-1 : 1989, 5.1.

If it is absolutely necessary to indicate that one pipe has to pass behind the other, the flow line representing the hidden pipe shall be interrupted (see figure 17). The width of each interruption shall not be less than five times the thickness of the continuous line.

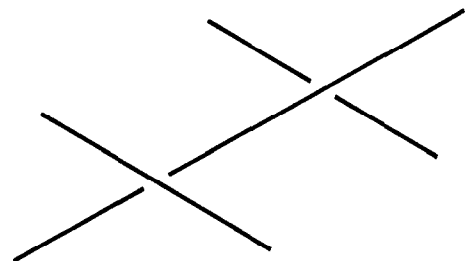

Figure 17

8.2.5 Permanent junctions

See examples of a weld in figure 18 and of a site weld in figure 19.

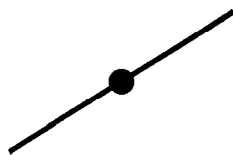

Figure 18

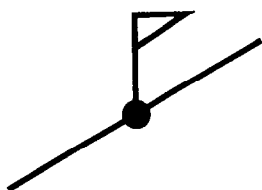

Figure 19

8.2.6 General connections

If the kind, or type, of connection is not specified, a general symbol should be used (instead of the more detailed symbols given in ISO 4067-1).

See example in figure 20.

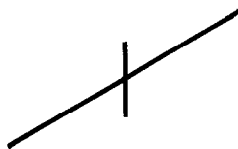

Figure 20

8.2.7 Flanges

See examples in figures 21 and 22.

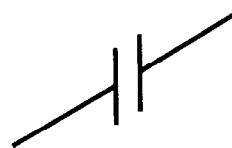

Figure 21



Figure 22

9 Examples

Examples of isometric projection are given in figures 23 and 24.

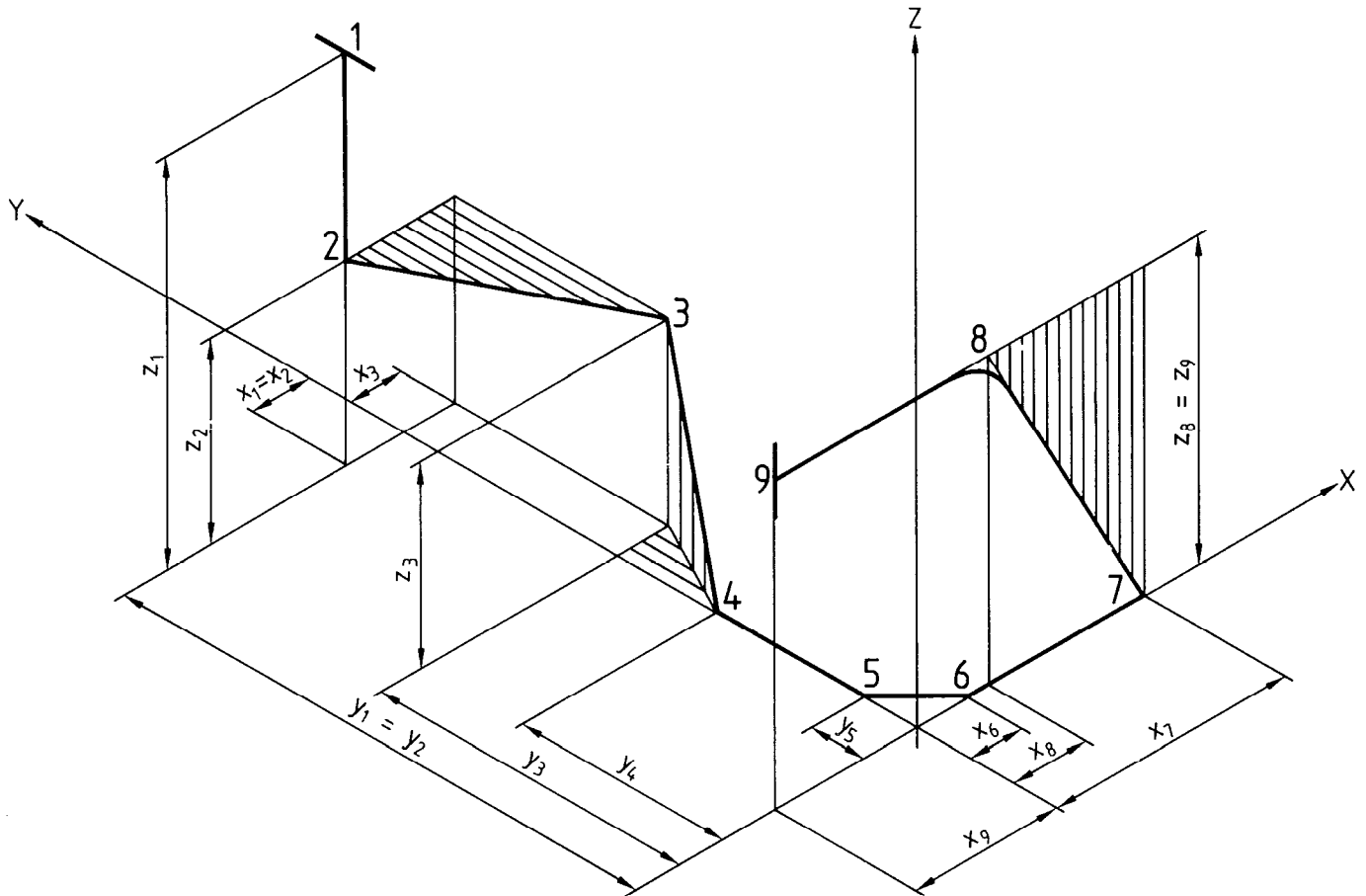

Reference number	Coordinates		
1	$x_1 = - 8$	$y_1 = + 72$	$z_1 = + 50$
2	$x_2 = - 8$	$y_2 = + 72$	$z_2 = + 25$
3	$x_3 = + 7$	$y_3 = + 42$	$z_3 = + 25$
4	$x_4 = 0$	$y_4 = + 28$	$z_4 = 0$
5	$x_5 = 0$	$y_5 = + 7$	$z_5 = 0$
6	$x_6 = + 7$	$y_6 = 0$	$z_6 = 0$
7	$x_7 = + 32$	$y_7 = 0$	$z_7 = 0$
8	$x_8 = + 10$	$y_8 = 0$	$z_8 = + 40$
9	$x_9 = - 20$	$y_9 = 0$	$z_9 = + 40$

NOTE — Points at which the pipe changes direction and connections are indicated by reference numbers. The pipe and the reference numbers are identical to those in the orthogonal representation illustrated in ISO 6412-1 : 1989, figure 25.

Figure 23

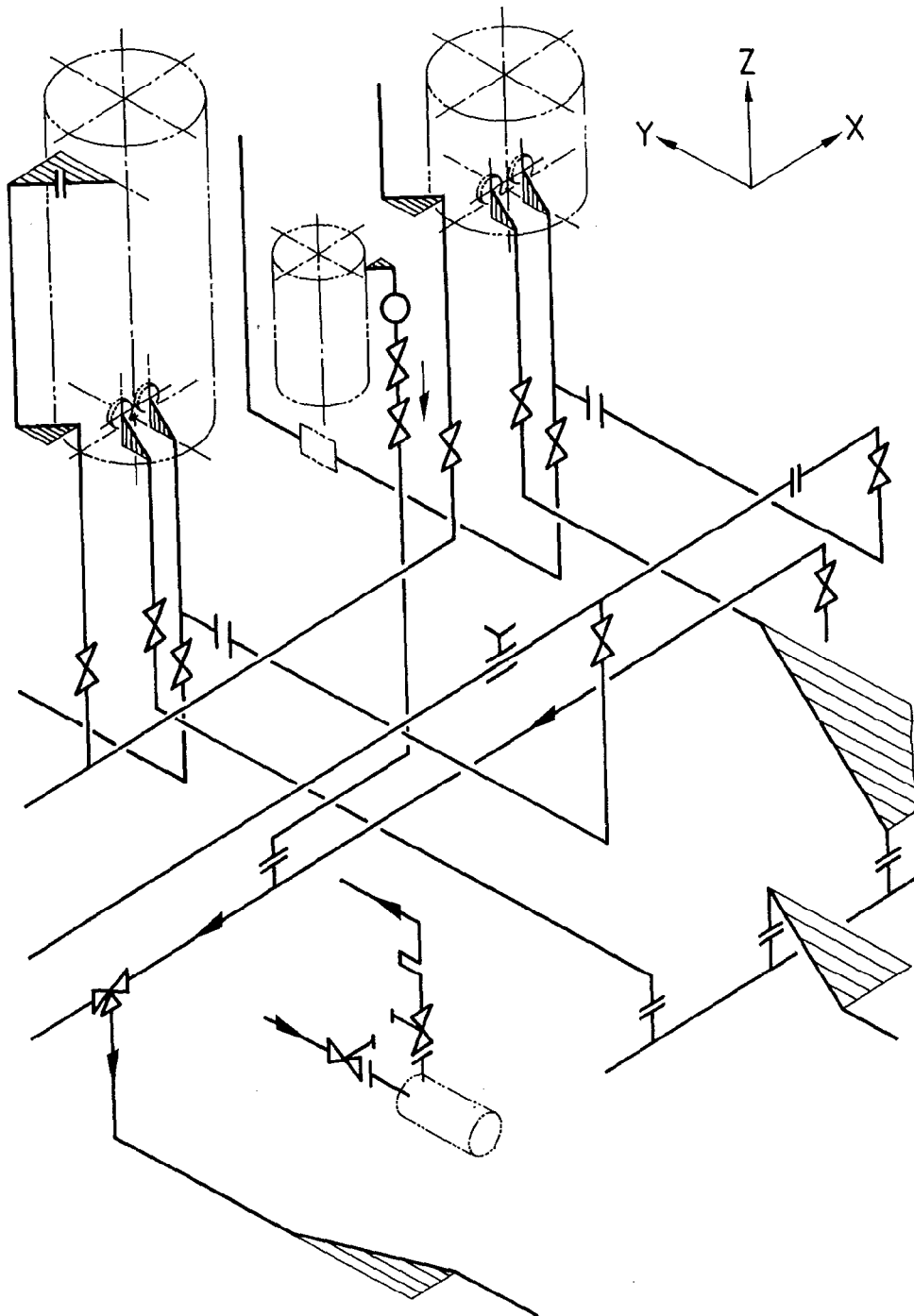

Figure 24

Annex A (informative)

Bibliography

ISO 406 : 1987, *Technical drawings — Tolerancing of linear and angular dimensions.*

ISO 841 : 1974, *Numerical control of machines — Axis and motion nomenclature.*

ISO 1219 : 1976, *Fluid power systems and components — Graphic symbols.*

ISO 1503 : 1977, *Geometrical orientation and direction of movements.*

ISO 3098-1 : 1974, *Technical drawings — Lettering — Part 1: Currently used characters.*

ISO 3511-1 : 1977, *Process measurement control functions and instrumentation — Symbolic representation — Part 1: Basic requirements.*

ISO 3511-2 : 1984, *Process measurement control functions and instrumentation — Symbolic representation — Part 2: Extension of basic requirements.*

ISO 3511-3 : 1984, *Process measurement control functions and instrumentation — Symbolic representation — Part 3: Detailed symbols for instrument interconnection diagrams.*

ISO 3511-4 : 1985, *Process measurement control functions and instrumentation — Symbolic representation — Part 4: Basic symbols for process computer, interface and shared display/control functions.*

ISO 4067-1 : 1984, *Technical drawings — Installations — Part 1: Graphical symbols for plumbing, heating, ventilation and ducting.*

ISO 4067-6 : 1985, *Technical drawings — Installations — Part 6: Graphical symbols for water supply and drainage systems in the ground.*

ISO 5455 : 1979, *Technical drawings — Scales.*

ISO 6412-2 : 1989 (E)

UDC 744.4 : 621.644

Descriptors : pipelines, drawings, technical drawings.

Price based on 9 pages
